



TECHNICAL DATA

MODEL LD-1 ANTI-COLUMN DEVICE

The Viking Corporation, 210 N Industrial Park Drive, Hastings MI 49058

Telephone: 269-945-9501 Technical Services: 877-384-5464 Fax: 269-818-1680 Email: techsvcs@vikingcorp.com

1. DESCRIPTION

The Model LD-1 Anti-Column Device is an optional trim component designed for use with dry pipe and preaction sprinkler systems. The anti-column device automatically prevents an unwanted water column from establishing within the system riser. On dry pipe systems the anti-column device prevents water from columning downstream of the dry valve. On preaction sprinkler systems the anti-column device prevents water from columning downstream of the easy riser check valve.

2. LISTINGS AND APPROVALS

cULus Listed: Category VLTR

FM Approved

3. TECHNICAL DATA

Specifications:

Available since 2008.

Inlet - 1/2" NPT Female

Outlet - 1/4" NPT Female

Orifice - 5/32"

Minimum System Air Pressure - 7 PSI (0.5 bar)

Maximum System Air Pressure - 85 PSI (5.86 bar)

Maximum Supply Water Pressure - 250 PSI (17 bar)

Material Standards:

Refer to Figure 3.

Ordering Information:

Part Number - 14800

Trim Part Number - 14816

Viking Technical Data may be found on
The Viking Corporation's Web site at
<http://www.vikinggroupinc.com>.
The Web site may include a more recent
edition of this Technical Data Page.



4. INSTALLATION

Installation on Dry Pipe Systems:

On dry systems, the LD-1 Anti-Column Device is installed on the dry valve conventional trim as shown in Figure 1. The component should be used on any dry system where the potential for a water column downstream of the dry valve exists.

Installation on Preaction Systems:

On preaction systems, the LD-1 Anti-Column Device is to be installed on the easy riser check valve as shown in Figure 2. The LD-1 anti-column device should be used on any preaction system where the potential for a water column downstream of the easy riser check valve exists.

Verification of Proper Operation:

Note: If the LD-1 Anti-Column Device is dropped or damaged prior to installation, verify that the device is working properly by taking the following steps:

1. With the LD-1 in the installation orientation (inlet facing up, outlet and cover screws facing down) blow a small amount of air into the inlet. No air should pass through.
2. With the LD-1 oriented opposite of the installation orientation (inlet facing down, outlet and cover screws facing up) blow a small amount of air into the inlet. Air should pass through.

If the LD-1 does not function as stated in steps 1 and 2 above, the unit must be replaced or rebuilt.

5. OPERATION

It is possible for small amounts of water to continue to drain back to the dry or easy riser check valve when the system is restored after operation. When water accumulates to the level of the of the LD-1 inlet, the internal float will rise, allowing the accumulated water to drain from the system. When the water has drained, the internal float will automatically seat and close the drain.

6. INSPECTIONS, TESTS AND MAINTENANCE

IT IS IMPERATIVE THAT THE SYSTEM BE INSPECTED AND TESTED ON A REGULAR BASIS. THE FREQUENCY OF THE INSPECTIONS MAY VARY DUE TO CONTAMINATED WATER SUPPLIES, CORROSIVE WATER SUPPLIES, OR CORROSIVE ATMOSPHERES. FOR MINIMUM MAINTENANCE AND INSPECTION REQUIREMENTS, REFER TO NFPA 25. IN ADDITION, THE AUTHORITY HAVING JURISDICTION MAY HAVE ADDITIONAL MAINTENANCE, TESTING, AND INSPECTION REQUIREMENTS THAT MUST BE FOLLOWED.



TECHNICAL DATA

MODEL LD-1 ANTI-COLUMN DEVICE

The Viking Corporation, 210 N Industrial Park Drive, Hastings MI 49058

Telephone: 269-945-9501 Technical Services: 877-384-5464 Fax: 269-818-1680 Email: techsvcs@vikingcorp.com

NOTE: If maintenance is required on the dry system which requires the dry valve to be opened, ensure that the system has been completely drained of air or water. Loosen the face plate bolts approximately 1/4" and break the seal on the cover plate gasket. This will ensure any residual water is relieved while the face plate bolts are still partially installed.

Replacing the Gasket and Link Assembly:

1. Close the 1/2" isolation valve on the LD-1 Trim.
2. Remove the LD-1 from the trim.
3. Remove the 12 nuts (11) and bolts (10).
4. Lift the shell welding (12) off of the base welding (13).
5. Remove the gasket (6) and replace with the new gasket.
6. Remove the float ball (8) and float link (3) from the support link (2). DO NOT unscrew Item 9.
7. Remove the slotted spring pin (7) from the support pin (1) by using a 1/8" solid pin to push it out.
8. Replace pre-assembled support link (2) and seal pin end cap assembly (4).
9. Install new slotted spring pin (7), split side face up.
10. Re-attach the float ball (8) and float link (3) to the support link (2).
11. If necessary, replace the screen basket (5).
12. Install the shell welding (12) over the new gasket (6) onto the base welding (13) and tighten the 12 cover screws (10) and nuts (11). Use 27-29 lb-in of torque.

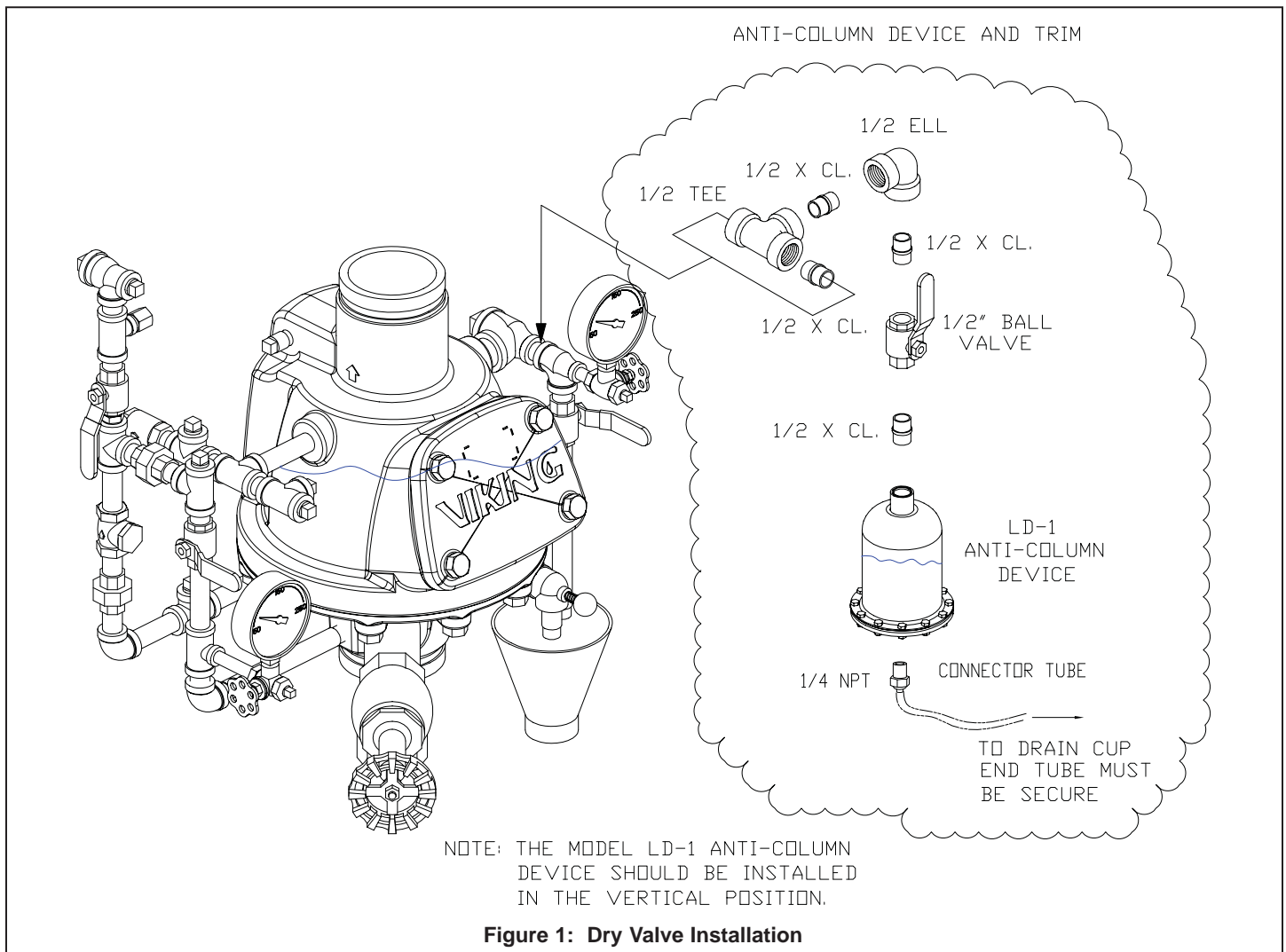



TECHNICAL DATA

**MODEL LD-1
ANTI-COLUMN DEVICE**

The Viking Corporation, 210 N Industrial Park Drive, Hastings MI 49058

Telephone: 269-945-9501 Technical Services: 877-384-5464 Fax: 269-818-1680 Email: techsvcs@vikingcorp.com

7. AVAILABILITY

The Viking Model LD-1 Anti-Column Device is available through a network of domestic and international distributors. See the Viking Corp. Web site for closest distributor or contact The Viking Corporation.

8. GUARANTEES

For details of warranty, refer to Viking's current list price schedule or contact Viking directly.

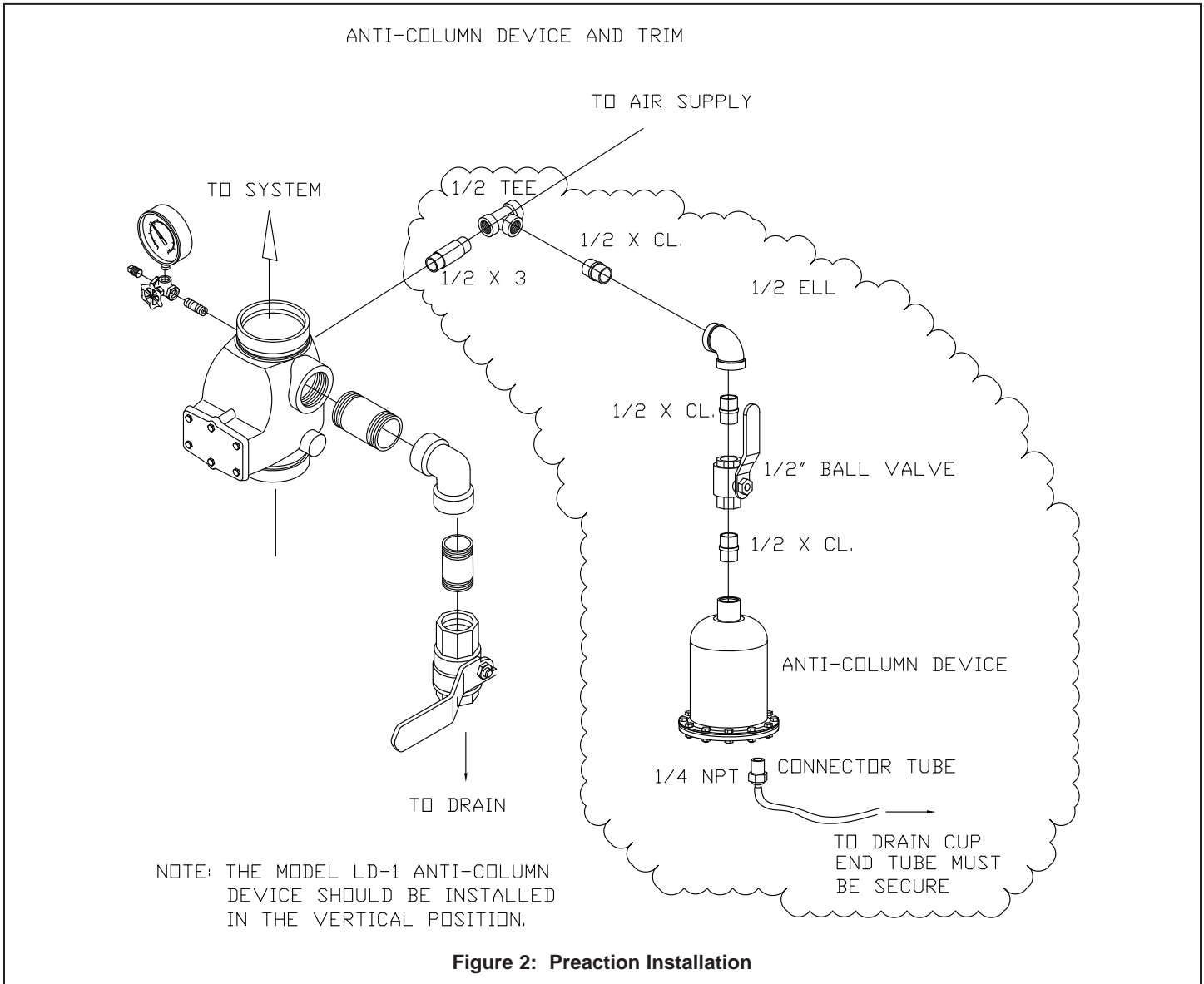



TECHNICAL DATA

**MODEL LD-1
ANTI-COLUMN DEVICE**

The Viking Corporation, 210 N Industrial Park Drive, Hastings MI 49058

Telephone: 269-945-9501 Technical Services: 877-384-5464 Fax: 269-818-1680 Email: techsvcs@vikingcorp.com

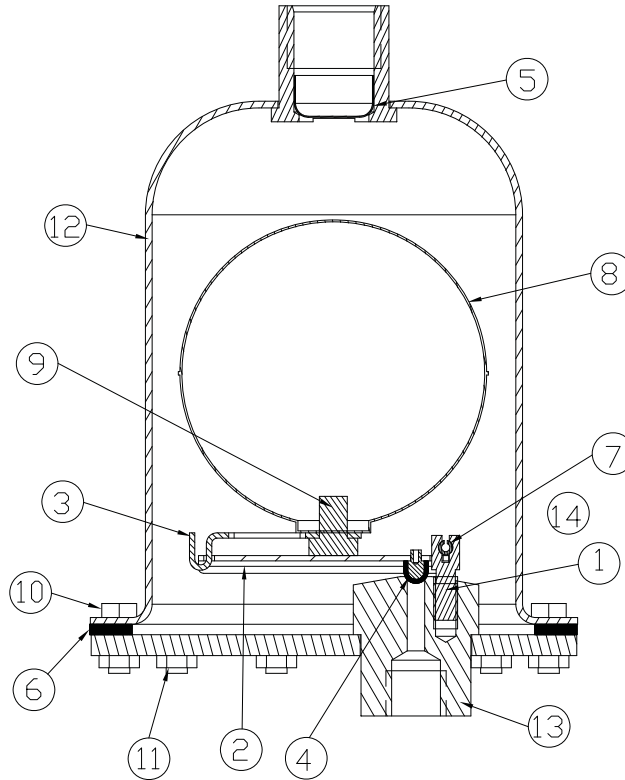

Figure 3: Replacement Parts

ITEM NO.	PART NUMBER	DESCRIPTION	MATERIAL	NO. REQ'D.
1	--	Support Pin	316 Stainless Steel	1
2	*	Support Link	304 Stainless Steel	1
3	*	Float Link	304 Stainless Steel	1
4	*	Seal Pin End Cap	EPDM - 60D	1
5	14804	Screen Basket	304 Stainless Steel	1
6	14805	Gasket	EPDM	1
7	14806	Slotted Spring Pin	18-8 Stainless Steel	1
8	*	Float Ball	303 Stainless Steel	1
9	*	1/4-20 X 3/4" HH Screw	Steel, Zinc Plated	1
10	04874A	#10-24 X 1/2" HHC Screw	304 Stainless Steel	12
11	01755A	#10-24 Hex Nut	304 Stainless Steel	12
12	--	Shell Welding		1
13	--	Base Welding		1
14	--	Label		1
-- Indicates replacement part not available.				
* Indicates replacement part only available in a Sub-Assembly listed below.				
SUB-ASSEMBLIES				
2, 3, 4, 6, 7, 8, 9	14824	Repair Kit		
2, 4	16300	Support Link Assembly		