



TECHNICAL DATA

**TRIMPAC® LPCB TYPE 1 MODEL
B-11 SINGLE INTERLOCKED
PREACTION SYSTEM WITH
ELECTRIC/PNEUMATIC RELEASE**

The Viking Corporation, 210 N Industrial Park Drive, Hastings MI 49058

Telephone: 269-945-9501 Technical Services: 877-384-5464 Fax: 269-818-1680 Email: techsvcs@vikingcorp.com

1. DESCRIPTION

TRIMPAC® Model B-11 LPCB Type 1 is a factory assembled trim package for a single interlocked preaction system with electric release module in a metal enclosure. The system piping is pneumatically pressurized for supervisory purposes only. This feature serves to prevent undetected leaks. If the system piping or a sprinkler is damaged, supervisory pressure is reduced and a "low air" alarm is activated. The standard trim normally required on a deluge valve has been moved to a single cabinet. TRIMPAC® Model B-11 provides access doors for the emergency release (B.1) and alarm test valve (B.7) for manual operation of these trim valves. TRIMPAC® Model B-11 is equipped with priming water pressure and water supply gauge view-ports for easy monitoring of water pressures. TRIMPAC® Model B-11 eliminates the installation of alarm trim piping and release trim piping at the deluge valve. The enclosure protects trim valves from inadvertent operation. The included stainless steel hoses (or field provided hard piping) from the valve body to the enclosure assembly allows the assembly to be installed remote of the sprinkler system riser. TRIMPAC® Model B-11 can be utilized for systems with valve sizes for DN50, DN80, DN100, and DN150. A valve drain package for the deluge valve is required and is ordered based on the deluge valve size. See Figure 7 for drain trim chart.



2. LISTINGS AND APPROVALS

LPCB Approved: The Viking supervised, electrically controlled single interlocked preaction system is LPCB Approved. Refer to the current LPCB Approval Guide.

3. TECHNICAL DATA

Specifications:

Rated Water Working Pressure: 250 psi (17.2 bar) (LPCB Approved to 16 bar)
Gauges: 0-300 PSI (0-20.7 bar)
Weight: 34 lbs. (15.4 kg.)
Dimensions: 16-1/8" (409 mm) high x 29-1/8" (748 mm) wide x 8-25/32" (223 mm) deep
U.S. Patent Number: 6,848,513

Material Standards:

Enclosure: 16 gauge steel, painted red: Epoxy Powder Coat
Gauges: Brass 1/4" NPT, Plastic Body
Pneumatic Actuator: Brass Body 1/2" (1.27 cm) connections
PORV: Brass Body, 250 PSI (17.2 bar)*, 1/2" NPT inlet, 1/2" NPT drain, 1/2" NPT sensing side
Solenoid Valves (2 NC): Brass Body 1/2" (1.27 cm), 24V Volt DC, 250 psi (17.2 bar)* NEMA Rated 1, 2, 3, 3S, 4 or 4X, 9 Watt
Ball valves: 1/2" NPT female ends
Strainer: Brass Body, 1/2" NPT inlet and outlet, 50 mesh screen
Restricted orifice: Brass Body, 1/2" NPT male inlet and outlet, 0.0625" orifice
Spring Loaded Check Valve: Brass Body, 1/2" NPT female inlet and outlet
Drain Check Valve: Brass Body, 1/2" NPT female inlet and outlet, EPDM clapper rubber
Hoses (4): Flexible braided stainless steel hoses with steel fittings and connectors, PTFE lined
Drain Hose (1): PVC Hose 60" long with brass hose connector x 1/2" NPT
Trim Piping: 1/2" Galvanized
Fittings: 1/2" Galvanized

Ordering Information:

Part No. - Galvanized 16582B-11

Accessories:

- Vertical Mounting Plate Kit - Part No. 11900
- Horizontal Mounting Plate Kit - Part No. 11901
- Hose Assembly Kit (Includes (4) Stainless Steel Hoses and (1) PVC Drain Hose) - Part No. 12072
- Individual 5'-0" Stainless Steel & PTFE Hose: Part No. 16558 (4) (included with Part No. 16582B-11)
- Individual PVC Hose: Part No. 12071 (1) (included with Part No. 16582B-11)
- Drain Package
 - Galvanized - DN50 (2") - 11894-2
 - Galvanized - DN80 (3") - 11894-3
 - Galvanized - DN100 & DN150 (4" & 6") - 11894-4

Viking Technical Data may be found on
The Viking Corporation's Web site at
<http://www.vikinggroupinc.com>.
The Web site may include a more recent
edition of this Technical Data Page.

	<h1 style="margin: 0;">TECHNICAL DATA</h1>	TRIMPAC® LPCB TYPE 1 MODEL B-11 SINGLE INTERLOCKED PREACTION SYSTEM WITH ELECTRIC/PNEUMATIC RELEASE
---	--	--

The Viking Corporation, 210 N Industrial Park Drive, Hastings MI 49058

Telephone: 269-945-9501 Technical Services: 877-384-5464 Fax: 269-818-1680 Email: techsvcs@vikingcorp.com

TABLE 1: IMPORTANT SETTINGS		
Device	WATER SUPPLY PRESSURES	
	Up to 175 PSI (12 bar) Set to Maintain	175 PSI (12 bar) to 250 PSI (17 bar)* Set to Maintain
Air Compressor On/Off Switch	40 PSI (2.8 bar)	60 PSI (4.1 bar)
Air Maintenance Device	30 PSI (2 bar)	50 PSI (3.4 bar)
Release System Pressure Supervisory Switch	25 PSI (1.7 bar) On Pressure Drop	45 PSI (3.1 bar) On Pressure Drop
*LPCB Approved to 16 bar.		

4. INSTALLATION (Refer to Figures 3, 5, and 7 for identification of trim components. Refer to Figure 6 for wall mounting.)

A. IMPORTANT SETTINGS

(Also refer to Table 1 above.)

1. Provide a minimum 30 PSI (2 bar) pneumatic pressure to the pneumatic release system and pneumatic actuator (B.13) for system water pressures of 175 PSI (12 bar) or less. For system water pressures above 175 PSI, up to a maximum of 250 PSI (17 bar)*, provide a minimum of 50 PSI (3.4 bar) pneumatic pressure to the pneumatic release system and pneumatic actuator (B.13).
2. Set release system air pressure supervisory switch (see page 261a-d) to activate at 25 PSI (1.7 bar) on pressure drop for system water pressures of 175 PSI (12 bar) or less. For system water pressures above 175 PSI, up to a maximum of 250 PSI (17 bar)*, set the air pressure supervisory switch (see page 261a-d) to activate at 45 PSI (3.1 bar) on pressure drop. Air pressure supervisory switch should be wired to activate an alarm to signal a low air pressure condition. Activation of an alarm to signal a high pressure condition may be required. Refer to applicable installation standards and the Authority Having Jurisdiction.
3. Recommended supervisory pressure in the closed sprinkler piping is 20 PSI (1.4 bar).
 - a. Where supervisory pressure is maintained at 20 PSI (1.4 bar), set air supervisory switch to activate at 15 PSI (1.03 bar) on pressure drop.
 - b. Air supervisory switch should be wired to activate an alarm to signal a “low air” pressure condition. Activation of an alarm to signal a high pressure condition may be required. Refer to applicable installation standards and the Authority Having Jurisdiction.
 - c. Supervisory air pressure on pneumatic actuator (B.13) must be set at a minimum 30 PSI (2.4 bar).

NOTE: Installation Standards may allow supervisory pressures lower than those recommended above. When using supervisory pressures lower than the recommended setting noted above, verify that air regulation equipment and air supervisory switches used are compatible with the supervisory pressure setting used.

4. Alarm pressure switch (D.1) should activate when pressurized to 4 to 8 PSI (0.3 to 0.6 bar) on pressure rise. Alarm pressure switch (D.1) should be wired to activate the water flow alarm.

B. AIR SUPPLY DESIGN

The air supply compressor should be sized to establish total required air pressure in 30 minutes. The air supply must be regulated, restricted and maintained automatically. Air maintenance device is used to regulate and restrict the flow of supervisory air into the sprinkler system piping.

The air supply must be regulated to maintain the supervisory pressure desired in the sprinkler piping. Pressures other than the pressure settings recommended in section 4. INSTALLATION, may affect operation of the system.

The air supply must be restricted to ensure that the automatic air supply cannot replace air as fast as it escapes when a sprinkler operates.

Riser Mounted Compressors (see page 261a-d):

A riser mounted compressor may be suitable for small electrically operated single interlocked preaction systems. However, placement of a dehydrator and/or an air maintenance device in the outlet piping of a riser mounted compressor may affect operation of the compressor.

1. When a dehydrator is not installed, verify that the installation is located in a dry environment (not humid) and that the supervised sprinkler piping is never subject to freezing.
2. When an air maintenance device is not used, verify that the air supply produced is properly “regulated” and “restricted”. See Air Supply Design paragraphs above, and section 7. INSPECTIONS and TESTS.
3. Verify system approval. Refer to the Authority Having Jurisdiction.

It is recommended practice to provide a test connection on the pneumatic release line for testing.

Preaction Panel Installation Requirements:

1. Solenoid valves shall be installed in parallel.
2. Solenoid valves shall function in pneumatic conditions only, and be protected by a strainer.
3. LPCB Certified detectors compatible with the control and indicating equipment shall be used.



TECHNICAL DATA

TRIMPAC® LPCB TYPE 1 MODEL B-11 SINGLE INTERLOCKED PREACTION SYSTEM WITH ELECTRIC/PNEUMATIC RELEASE

The Viking Corporation, 210 N Industrial Park Drive, Hastings MI 49058

Telephone: 269-945-9501 Technical Services: 877-384-5464 Fax: 269-818-1680 Email: techsvcs@vikingcorp.com

4. Suitable electrical detection, control and indicating equipment and pneumatic systems shall be used. The control and indicating equipment should be LPCB certified.
5. Connecting cables shall comply with BS 6387: 1994, classification, C, W, Z evidenced by LPCB certification.
6. Preaction systems shall be electrically monitored to demonstrate that they are in a "ready to operate" state at all times.
7. Clear dry air shall be used. Compressor tank must have provision for draining.
8. Preaction system equipment shall be installed, operated and maintained as prescribed in the technical data pages for individual components.
9. Preaction systems shall be configured in accordance with the manufacturer's specifications.
10. Preaction systems shall comply with the details specified in the related LPC Technical Bulletin TB208: Supplementary Requirements for Sprinkler Installations which can operate in the dry mode.
11. The company responsible for the complete preaction station, including electrics, shall be identified.
12. Normally unenergized solenoids may be used, provided that they are continuously monitored for "open" and "short circuit".

C. TRIMPAC® MODEL B-11

1. The TRIMPAC® Model B-11 Trim Assembly may be installed with angle style Model E Deluge Valves, sizes DN50, DN80, DN100, and DN150".
2. **TRIMPAC® Model B-11 trim assembly and valve must be installed in an area not subject to freezing.**
3. **TRIMPAC® Model B-11 trim assembly must be installed to facilitate drainage.**
4. **TRIMPAC® Model B-11 trim assembly must be installed above the elevation of the drip check valve (C.2).**
5. The TRIMPAC® Model B-11 Trim Assembly can be installed with the furnished hose package or ½" non-corrosive metallic piping. The maximum distance the TRIMPAC® Model B-11 may be installed away from the deluge/flow control valve is 5'-0".
6. The deluge valve equipped with TRIMPAC® Model B-11 must be installed in accordance with Viking Technical data. The required drain package must be installed in accordance with Figure 7.
 - a. Remove all plastic thread protectors from the openings of the deluge/flow control valve and the TRIMPAC® Model B-11 trim assembly.
 - b. Apply a small amount of pipe-joint compound or tape to the external threads of all pipe connections required. Take care not to allow any compound, tape, or other foreign matter inside any of the nipples or openings of the valve or trim components.
 - c. Verify that all system components are rated for the water working pressure of the system.

Hydrostatic Test: The Viking deluge valve is manufactured and listed for use at a maximum Water Working Pressure of 250 PSI (17.2 bar)*. The valve is factory tested at 500 psi (34.5 bar). The Viking deluge/flow control valve may be hydrostatically tested at 300 PSI (20.7 bar) and/or 50 PSI (3.5 bar) above the normal Water Working Pressure, for limited periods of time (2 hours) for the purpose of acceptance by the Authority Having Jurisdiction. If air testing is required, DO NOT exceed 40 psi (2.8 bar) air pressure.

Trim Note: (Refer also to System Data and/or Trim Chart.) Discharge piping from the auxiliary drain valve (C.1), the flow test valve (C.4), and all system drains should be kept separate. DO NOT connect the outlet of the drip check (C.2) to any other drain.

7. The priming line must be connected upstream of the system water supply main control valve (E.1).
8. After the deluge valve is set, operation of the deluge valve requires the release of priming water from the priming chamber. For TRIMPAC® Model B-11 the release of the priming water from the priming chamber will be automatically controlled by the electric release system that is installed in the hazard area. Upon activation of the electric release system, system control panel (G.1) activates an alarm and energizes normally closed solenoid valves (B.12) open. This in turn allows the pneumatic actuator (B.13) to open, which will then relieve priming water pressure from the priming chamber.

CAUTION: OPERATION OF VIKING DELUGE VALVE BY PRESSURIZING THE PRIMING CHAMBER WITH AIR PRESSURE OR ANY OTHER PRESSURIZED GAS IS NOT RECOMMENDED OR APPROVED.

9. Placing the System in Service: (Refer to Figures 3, 5, and 7.)

- a. Verify:
 - i. The system main water supply control valve (E.1) is closed and that the TRIMPAC® Model B-11 and required drain package is installed according to Viking Trim Charts and schematic drawings for the system used.
 - ii. The system has been properly drained.
 - iii. Auxiliary drain (C.1) is open.
 - iv. The emergency release (B.1) is closed. **Note:** Emergency release (B.1) is closed when the handle is in-line with the pipe. This allows the door to close when the valve is in the normal position.
 - v. The system water supply piping is pressurized up to the closed main water supply control valve (E.1) and the priming line is pressurized up to the closed priming valve (B.2).
- b. Restore supervisory pressure to sprinkler piping (30 psi air pressure is recommended for systems subject to water pressures of 175 psi, where water pressures are in excess of 175 psi, 50 psi air pressure is recommended). Verify that the 1/2" valve in the Air Maintenance Device (see page 261a-d) by-pass trim is closed and that both 1/4" valves are open.
- c. Restore release air supply to the pneumatic actuator (B.13). Make sure the shut-off valve (B.10) is open. The air gauge



TECHNICAL DATA

**TRIMPAC® LPCB TYPE 1 MODEL
B-11 SINGLE INTERLOCKED
PREACTION SYSTEM WITH
ELECTRIC/PNEUMATIC RELEASE**

The Viking Corporation, 210 N Industrial Park Drive, Hastings MI 49058

Telephone: 269-945-9501 Technical Services: 877-384-5464 Fax: 269-818-1680 Email: techsvcs@vikingcorp.com

should show the desired air pressure.

- d. Establish a normal condition on the release control panel (G.1).
- e. Open the priming valve (B.2).
- f. Open the flow test valve (C.4).
- g. Partially open the main water supply control valve (E.1).
- h. When full flow develops from flow test valve (C.4), close the flow test valve. Verify that there is no flow from the open auxiliary drain (C.1).
- i. Close the auxiliary drain (C.1).
- j. Fully open and secure the main water supply control valve (E.1).
- k. Verify that the alarm shut-off valve (B.10) is open and that all other valves are in their normal operating position.
- l. Depress the plunger of drip check (C.2). No water should flow from the drip check when the plunger is pushed.
- m. Check for and repair all leaks.
- n. On new installations, those systems that have been placed out of service or where new equipment has been installed, trip test the system to verify that all equipment functions properly. Refer to the deluge valve data page for maintenance of the valve.

CAUTION: PERFORMING A TRIP TEST RESULTS IN OPERATION OF THE DELUGE VALVE. WATER WILL FLOW INTO THE SPRINKLER PIPING. TAKE NECESSARY PRECAUTIONS TO PREVENT DAMAGE.

- o. Valve Removed from Service.

NOTE: WHEN A VALVE HAS BEEN REMOVED FROM SERVICE AND IS SUBJECT TO FREEZING OR WILL BE OUT OF SERVICE FOR AN EXTENDED PERIOD OF TIME, ALL WATER MUST BE REMOVED FROM THE PRIMING CHAMBER, TRIM PIPING, WATER SUPPLY PIPING, AND OTHER TRAPPED AREAS.

5. OPERATION (Refer to Figures 3, 5, and 7.)

TRIMPAC® Model B-11 incorporates an electric release module that controls the pressurization of the priming chamber of the deluge valve. Water is supplied to the deluge valve's priming chamber from an outlet upstream of the water supply control valve. Water flow to Point #1 of TRIMPAC® Model B-11, passes through the normally opened priming valve (B.2), Y strainer (B.3), 1/16" restricted orifice (B.4) and spring loaded check valve (B.5). Air is supplied to the inlet side of the normally closed solenoids (B.12) and pneumatic actuator (B.13), and water to the priming side of the PORV (B.11). Priming water exits the TRIMPAC® Model B-11 at Point #2 of the TRIMPAC®, passing to the priming chamber of the deluge valve (A.1), pressurizing the deluge valve closed. (Priming pressure can be identified at the priming pressure gauges view-port on the TRIMPAC® Model B-11.) Once priming pressure is present in the priming chamber of the deluge valve, the water supply control valve (E.1) can be opened. Once the water supply control valve is opened, water will pressurize the inlet chamber of the deluge valve, water will exit the inlet chamber of the deluge valve and enter Point #5 of the TRIMPAC® Model B-11. After water enters Point #5 of the TRIMPAC® Model B-11 it will pressurize the water supply pressure gauge (B.9). Water pressure will now be available on the inlet of the normally closed alarm test valve (B.7). The valve and trim assembly is now in a normal operation mode.

In Fire Conditions:

Single Interlocked Preaction systems with an electric release require a compatible electric release device (or combination of compatible electric release devices) to activate in the hazard area, which initiates a power sequence from the listed release control panel (G.1) to open the normally closed solenoid valves (B.12). This allows the pneumatic actuator (B.13) to open, which in turn releases the water pressure in the deluge valve's priming chamber. Air is released from the outlet of the solenoid valves (B.12). Once the priming water pressure is relieved in the priming chamber of the deluge valve, water supply pressure will pass from the inlet of the deluge valve to the outlet of the deluge valve to the sprinkler piping. During deluge valve operation, water is discharged through the valve drain package to Point #4 of the TRIMPAC® Model B-11. Water enters Point #4 of the TRIMPAC® Model B-11 to activate the water flow alarms and pressurize the sensing side of the PORV (B.11). Once the sensing side of the PORV (B.11) is pressurized, priming water will be vented from the drain end of the PORV (B.11) through Point #3 of TRIMPAC® Model B-11 to the drain package (drain cup) (C.3).

To return the system to "Normal" conditions, drain the system piping and replace any sprinklers that may have operated. Replace any detectors that have been damaged. Re-establish system air pressure by following the steps in section 4. INSTALLATION, Step 9 Placing the System in Service.

6. INSPECTIONS, TESTS, AND MAINTENANCE

It is imperative that the system be inspected and tested on a regular basis. The frequency of the inspections may vary due to contaminated water supplies, corrosive water supplies, or corrosive atmospheres. Also, the alarm devices, detection systems, or other connected trim may require a more frequent schedule. For minimum maintenance and inspection requirements, refer to NFPA 25. In addition, the Authority Having Jurisdiction may have additional maintenance, testing, and inspection requirements that must be followed. Refer to the specific Viking deluge valve data page for periodic testing.

Maintenance: TRIMPAC® Model B-11 should be inspected, tested, and maintained in accordance with the latest edition of NFPA 25, The Standard for Inspection, Testing, and Maintenance of water based fire protection systems, and in accordance with the Authority Having Jurisdiction.



TECHNICAL DATA

TRIMPAC® LPCB TYPE 1 MODEL
B-11 SINGLE INTERLOCKED
PREACTION SYSTEM WITH
ELECTRIC/PNEUMATIC RELEASE

The Viking Corporation, 210 N Industrial Park Drive, Hastings MI 49058

Telephone: 269-945-9501 Technical Services: 877-384-5464 Fax: 269-818-1680 Email: techsvcs@vikingcorp.com

NOTICE: THE OWNER IS RESPONSIBLE FOR MAINTAINING THE FIRE PROTECTION SYSTEM AND DEVICES IN PROPER OPERATING CONDITION. THE DELUGE VALVE MUST BE KEPT FROM FREEZING CONDITIONS AND PHYSICAL DAMAGE THAT COULD IMPAIR ITS OPERATION. WHERE DIFFICULTY IN PERFORMANCE IS EXPERIENCED, THE VALVE MANUFACTURER OR AUTHORIZED REPRESENTATIVE SHALL BE CONTACTED IF ANY FIELD ADJUSTMENT IS TO BE MADE.

⚠ WARNING

Any system maintenance that involves placing a control valve or detection system out of service will impair the fire protection capabilities of that system. Prior to proceeding, appropriate impairment procedures per NFPA 25 shall be followed with the notification of all Authorities Having Jurisdiction. Consideration should be given to employment of a fire patrol in the affected areas.

Failure to follow these instructions could cause improper system operation, resulting in serious personal injury and/or property damage.

After Each Operation: Sprinkler systems that have been subjected to a fire must be returned to service as soon as possible. The entire system must be inspected for damage, and repaired or replaced as necessary. Deluge valves and TRIMPAC® Model B-11 that have been subjected to brackish water, salt water, foam, foam/water solution, or any other corrosive water supply should be flushed with good quality fresh water before being returned to service. Refer to specific deluge valve for maintenance schedule.

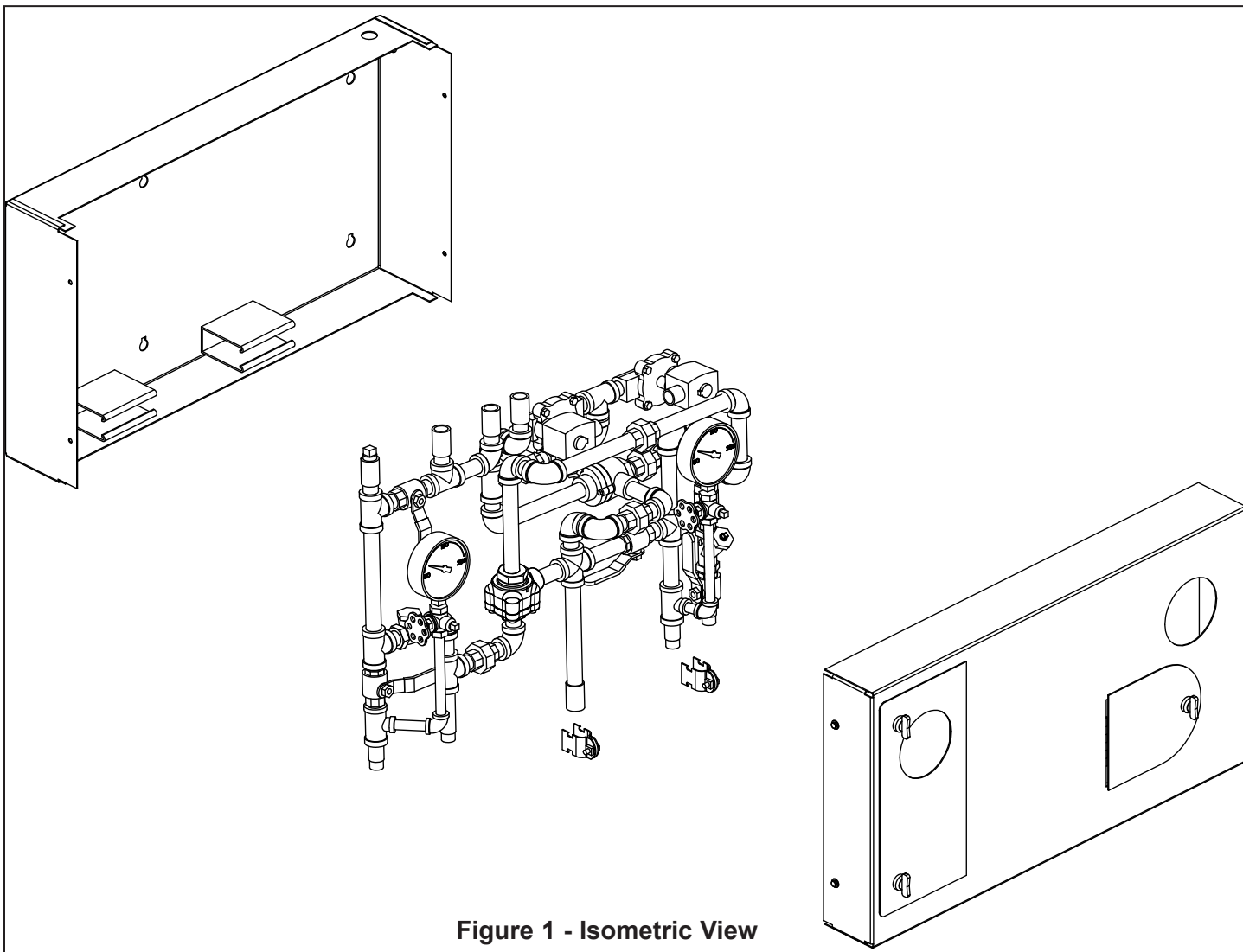

Figure 1 - Isometric View

	<h1 style="margin: 0;">TECHNICAL DATA</h1>	<p>TRIMPAC® LPCB TYPE 1 MODEL B-11 SINGLE INTERLOCKED PREACTION SYSTEM WITH ELECTRIC/PNEUMATIC RELEASE</p>
---	--	---

The Viking Corporation, 210 N Industrial Park Drive, Hastings MI 49058

Telephone: 269-945-9501 Technical Services: 877-384-5464 Fax: 269-818-1680 Email: techsvcs@vikingcorp.com

7. AVAILABILITY

The Viking TRIMPAC® Model B-11 is available through a network of domestic and international distributors. See the Viking Corp. Web site for closest distributor or contact The Viking Corporation.

8. GUARANTEE

For details of warranty, refer to Viking's current list price schedule or contact Viking directly.

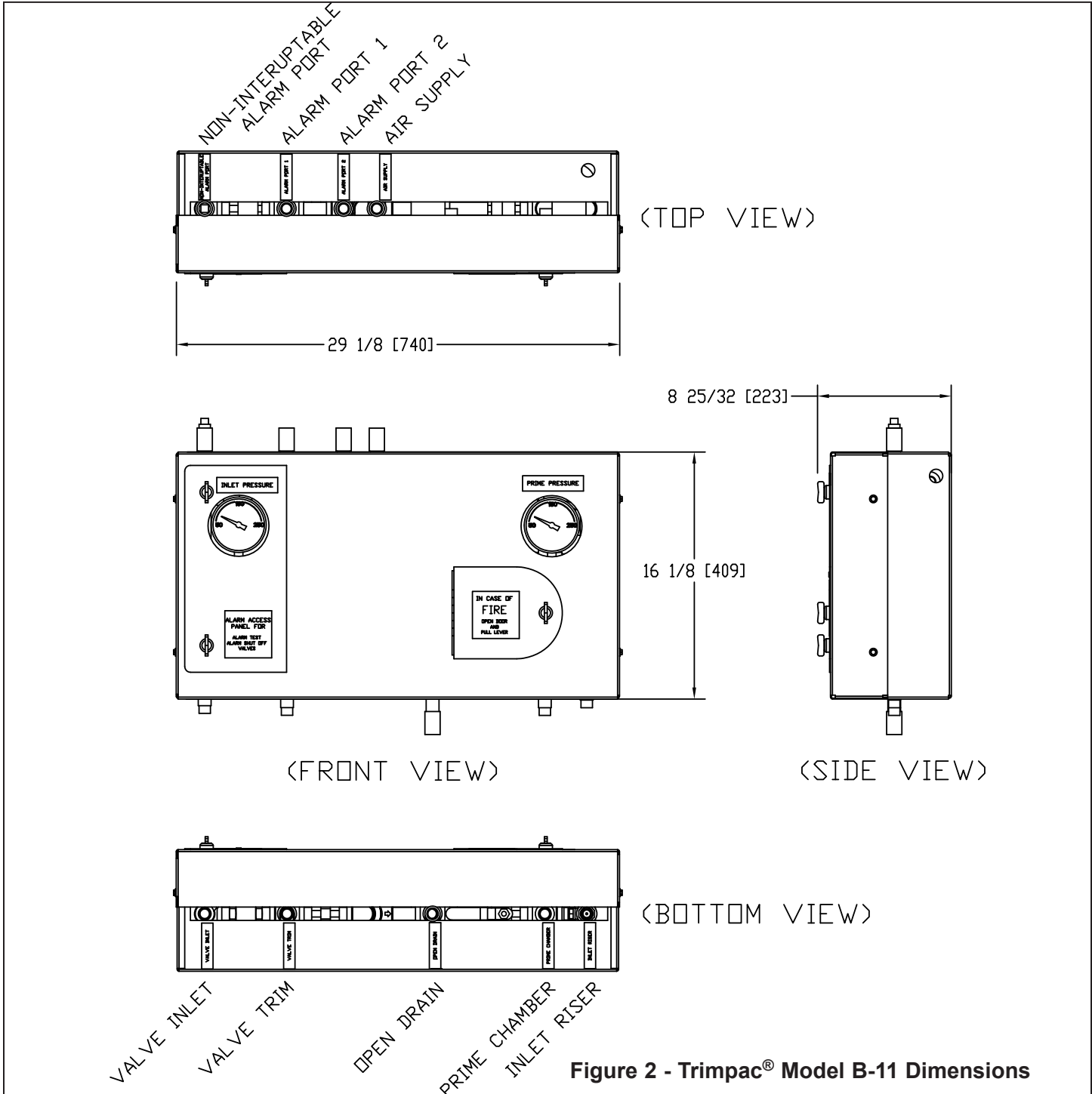

Figure 2 - Trimpac® Model B-11 Dimensions

	<h1 style="margin: 0;">TECHNICAL DATA</h1>	TRIMPAC® LPCB TYPE 1 MODEL B-11 SINGLE INTERLOCKED PREACTION SYSTEM WITH ELECTRIC/PNEUMATIC RELEASE
---	--	--

The Viking Corporation, 210 N Industrial Park Drive, Hastings MI 49058

Telephone: 269-945-9501 Technical Services: 877-384-5464 Fax: 269-818-1680 Email: techsvcs@vikingcorp.com



Component	Description	Part Numbers	Corresponding Data Pages
System Valve			
A	A.1	Deluge Valve	Various (DN50, DN80, DN100, DN150)
			210 through 211
Trimpac			
B			16582B-11
	B.1 - B.13	TRIMPAC® Components	Refer to Figure 5.
Trimpac Drain Package			
C	C.1	Auxiliary Drain Valve (NC)	Galv. DN50 (2") - 11894-2 DN80 (3") - 11894-3 DN100 & DN150 (4" & 11894-4
	C.2	Drip Check Valve	
	C.3	Drain Cup	
	C.4	Flow Test Valve (NC)	
Water Flow Alarm Equipment			
D	D.1	Alarm Pressure Switch	PS101A
	D.2	Water Motor Alarm (F-2)	07862
	D.3	Strainer	01489A
	D.4	Electric Alarm Bell	--
Riser			
E	E.1	Water Supply Control Valve	--
Check Valve			
F	F.1	1-1/2"-2" Model L-1 Check Valve, 4" Model M-2 Check Valve, or 3"-8" Easy Riser® Check Valve	Various
	F.2	Check Valve Trim	Various
Electric/Pneumatic Release System			
G	G.1	Air Pressure Gauge and Valve	01124A
	G.2	Soft Seat Check Valve	03945A
	G.3	Air Pressure Supervisory Switch	PS401A
	G.4	Ball Valve	--
	G.5	Air Maintenance Device w/trim	07459
	G.6	Fixed Temperature Release (and/or)	07848 (plus finish suffix)
	G.7	Pilot Head (Sprinkler)	Various
H	H.1	VFR-400 Multi-Hazard Release Control Panel	14152-1
	H.2	Electrical Detection System (Heat Detector Shown for Clarity)	Various
	H.3	Model E-1 Accelerator (Optional)	08055
	H.4	Ball Valve	Various
Air Supply			
I	--	Air Line Trim for Tank Mounted Compressor	13770
	--	Air Line Trim for Riser Mounted Compressor	13771

Table 1 - Trimpac System Components

Refer to Figures 3 through 7 for component identification.

Note: When viewing this Data Page online, **blue** text represents hyperlinks and will open the desired data page when clicked.

Legend for Figure 3

- Dotted lines indicate electrical system wiring required but not listed in "System Components" Table. For additional wiring requirements refer to technical data for components used.
- Dashed lines indicate pipe required but not included with TRIMPAC trim packages. Minimum 1/2" nominal piping recommended.
-  Smaller diameter hoses are the (4) included flexible braided stainless steel hoses. Also available as a kit (P/N) 12072
-  Larger diameter hose is the included PVC Drain Hose. Also available separately (P/N 12071).
- ** 1/2" (15 mm) NPT for non-interruptible Alarm Pressure Switch (Optional)



TECHNICAL DATA

TRIMPAC® LPCB TYPE 1 MODEL B-11 SINGLE INTERLOCKED PREACTION SYSTEM WITH ELECTRIC/PNEUMATIC RELEASE

The Viking Corporation, 210 N Industrial Park Drive, Hastings MI 49058

Telephone: 269-945-9501 Technical Services: 877-384-5464 Fax: 269-818-1680 Email: techsvcs@vikingcorp.com

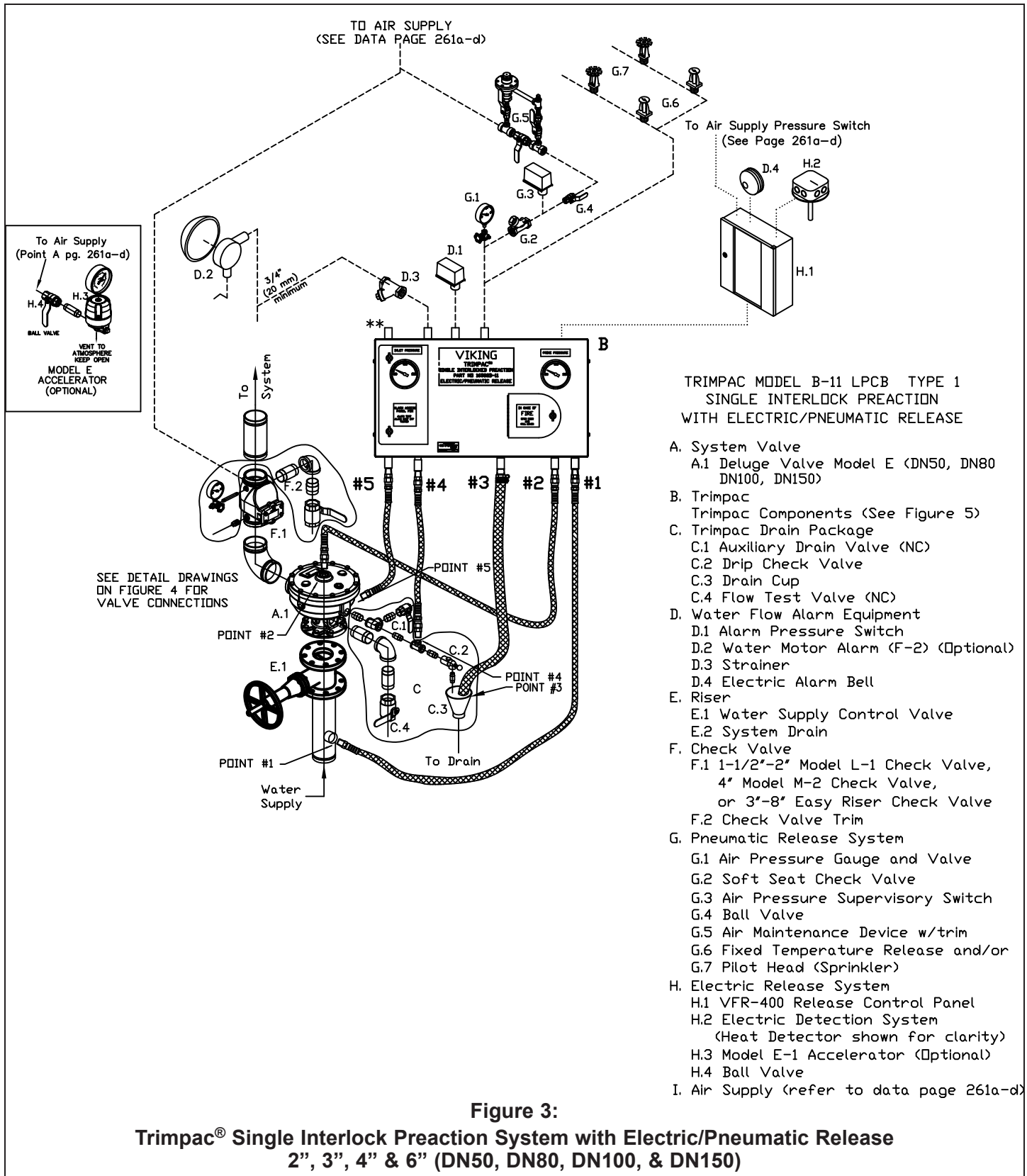

Figure 3:

Trimpac® Single Interlock Preaction System with Electric/Pneumatic Release
 2", 3", 4" & 6" (DN50, DN80, DN100, & DN150)



TECHNICAL DATA

TRIMPAC® LPCB TYPE 1 MODEL B-11 SINGLE INTERLOCKED PREACTION SYSTEM WITH ELECTRIC/PNEUMATIC RELEASE

The Viking Corporation, 210 N Industrial Park Drive, Hastings MI 49058

Telephone: 269-945-9501 Technical Services: 877-384-5464 Fax: 269-818-1680 Email: techsvcs@vikingcorp.com

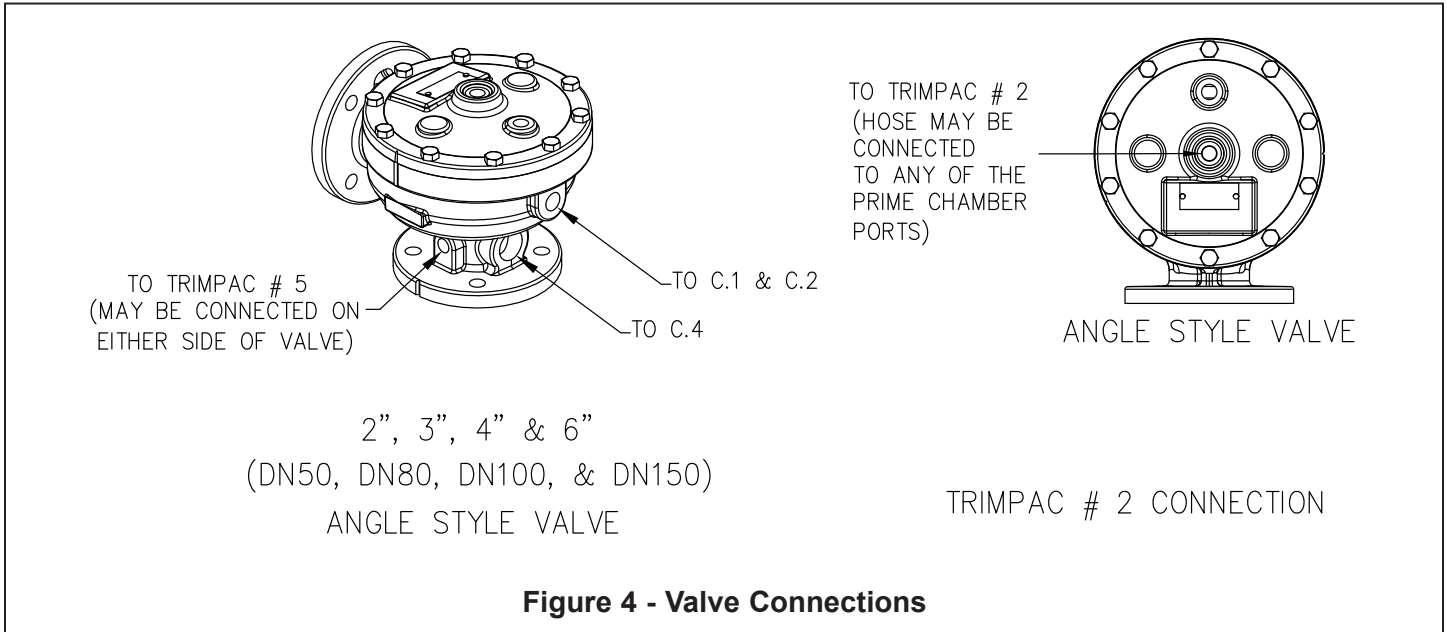

Figure 4 - Valve Connections

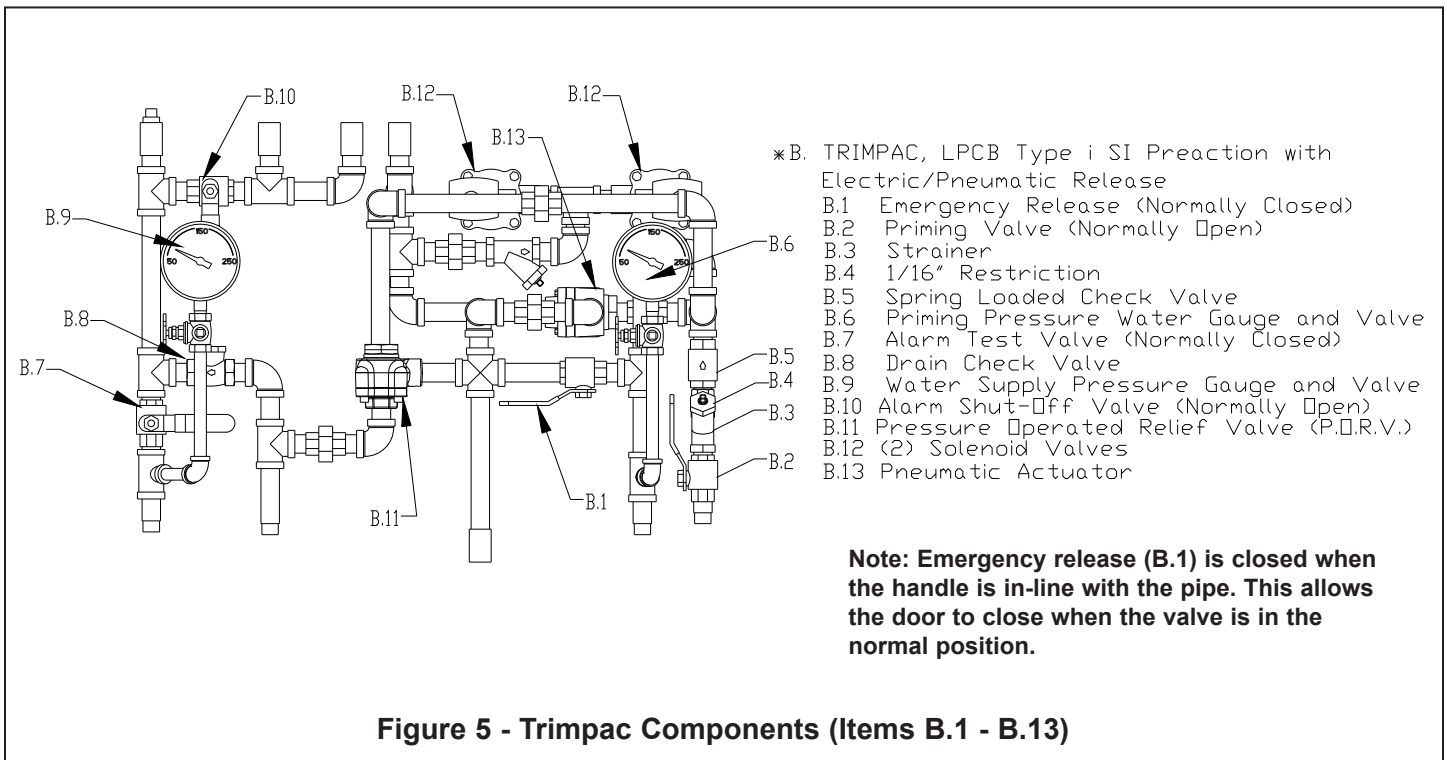

Figure 5 - Trimpac Components (Items B.1 - B.13)



TECHNICAL DATA

TRIMPAC® LPCB TYPE 1 MODEL B-11 SINGLE INTERLOCKED PREACTION SYSTEM WITH ELECTRIC/PNEUMATIC RELEASE

The Viking Corporation, 210 N Industrial Park Drive, Hastings MI 49058

Telephone: 269-945-9501 Technical Services: 877-384-5464 Fax: 269-818-1680 Email: techsvcs@vikingcorp.com

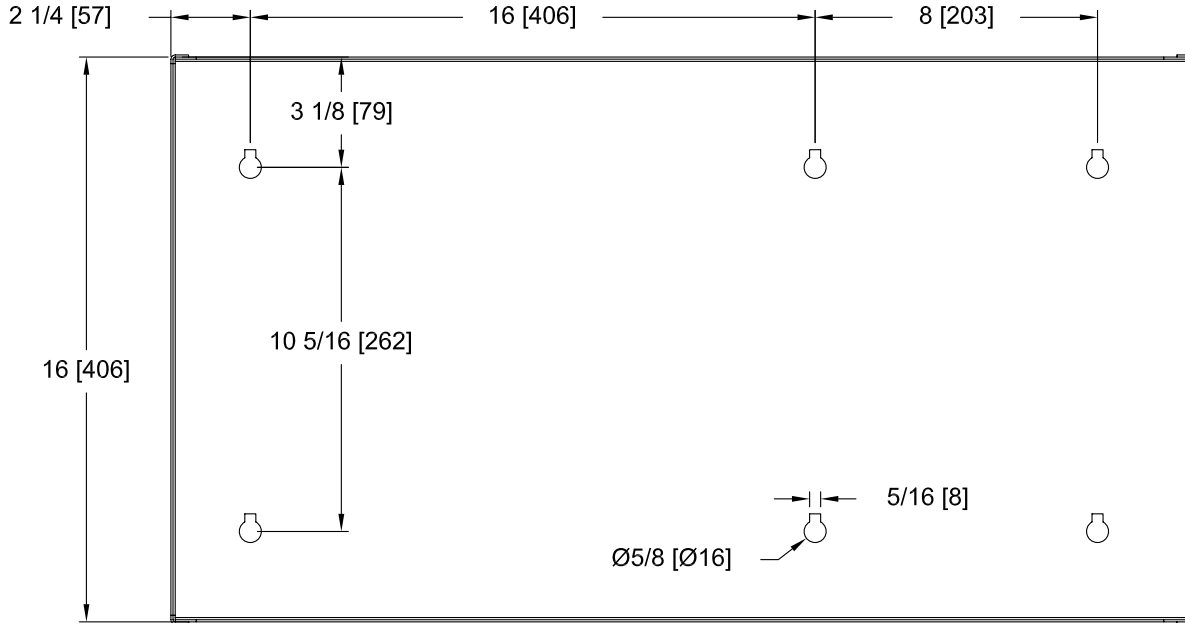

Wall Mounting Notes:

1. Mounting Fasteners are supplied by the contractor.
2. Recommended Fasteners - Minimum 1/4" x 1-1/2 Lg. Hex Head lag screws with washers.
3. When installing into concrete, drywall or metal, use typical grommet.
4. Approximate Weight of TRIMPAC® Model B-11 and Flexible Hoses: 34 lbs. (15.4 kg)

Figure 6 - Installation Dimensions

**2", 3", 4" & 6"
(DN50, DN80, DN100 & DN150)
Angle Style Valve Drain Package Trim Chart**

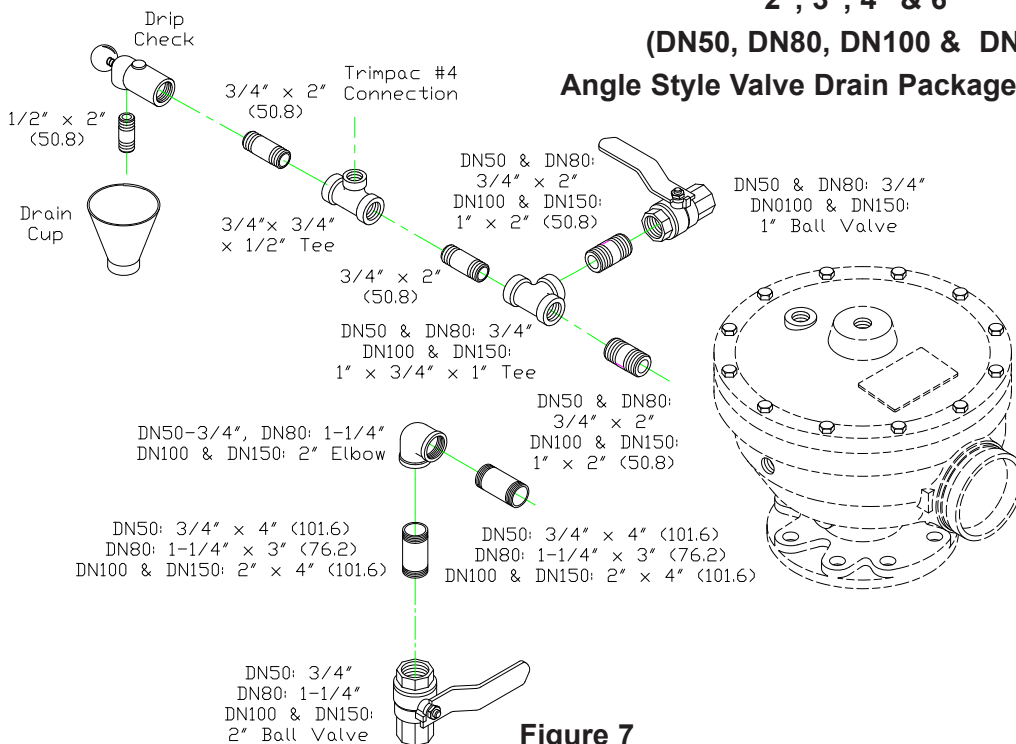

Figure 7

THIS PAGE INTENTIONALLY
LEFT BLANK