



TECHNICAL DATA

PILOT REGULATING DELUGE TRIM

2-1/2" & 3" (DN65 & DN80) MODEL J
VERTICAL FLOW CONTROL VALVE

The Viking Corporation, 210 N Industrial Park Drive, Hastings MI 49058

Telephone: 269-945-9501 Technical Services 877-384-5464 Fax: 269-945-4495 Email: techsvcs@vikingcorp.com

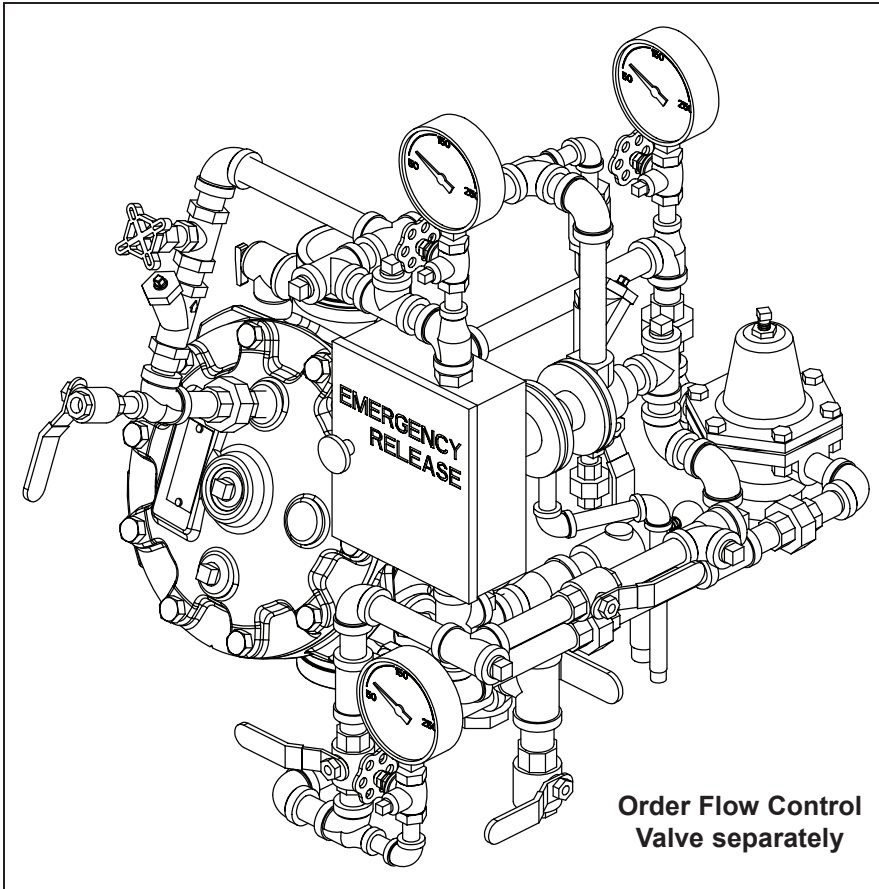

Order Flow Control Valve separately

This Trim Chart is for use with the following Viking Trim Sets		
Valve Size	Galvanized Trim Part No.	Brass Trim Part No.
2-1/2" (DN65) & 3" (DN80)	14747-1	14747-2
This trim is for use with the following Release Module Trim Kits		
Release Type	Galvanized	Brass
Electric	10830	10832
Pneumatic	10809	10811
Note: Nipple lengths for brass trim may vary from those shown on this Trim Chart.		

Note: When viewing this data page online, blue text represents hyper links and will open the appropriate data page when clicked.

Notes: For use with Trim Chart on Page 541 e

General Notes:

- Valve must be trimmed as shown. Any deviation from trim size or arrangement may affect the proper operation of the valve.
- Dimensions in parentheses are millimeters.
- Viking uses ANSI tee designs (large outlet on run, small outlet on run, side outlet) in all trim call-outs.

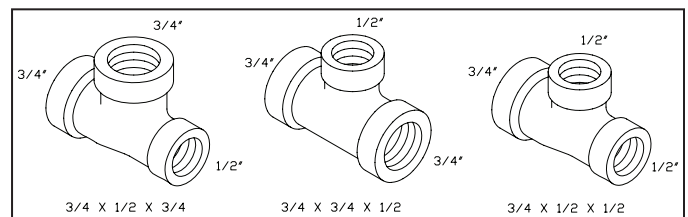

Note 1: Release System connection. Viking Flow Control Valves are compatible with hydraulic, pneumatic, and electric release systems. A Pneumatic Actuator is required on all Viking Flow Control Valves equipped with Pneumatic Release Systems.

Note 2: Alarm Connections: Connect alarm line piping to 3/4" (20 mm) NPT outlet. When using a Water Motor Alarm, a strainer is required. 1/2" (15 mm) NPT outlet is for electric Alarm Pressure Switch.

Note 3: Optional non-interruptible connection for Alarm Pressure Switch to activate electric alarm panel. Note: After the Flow Control Valve trips, this location cannot be shut off. Alarms may operate until the outlet chamber of the Flow Control Valve is depressurized below the set point of the Alarm Pressure Switch.

Note 4: Viking Drain Check Valve is manufactured with a 0.067" (1.7 mm) orifice to allow alarm line to drain. Do not substitute. Check label for proper orientation.



TECHNICAL DATA

PILOT REGULATING DELUGE TRIM 2-1/2" & 3" (DN65 & DN80) MODEL J VERTICAL FLOW CONTROL VALVE

The Viking Corporation, 210 N Industrial Park Drive, Hastings MI 49058

Telephone: 269-945-9501 Technical Services 877-384-5464 Fax: 269-945-4495 Email: techsvcs@vikingcorp.com

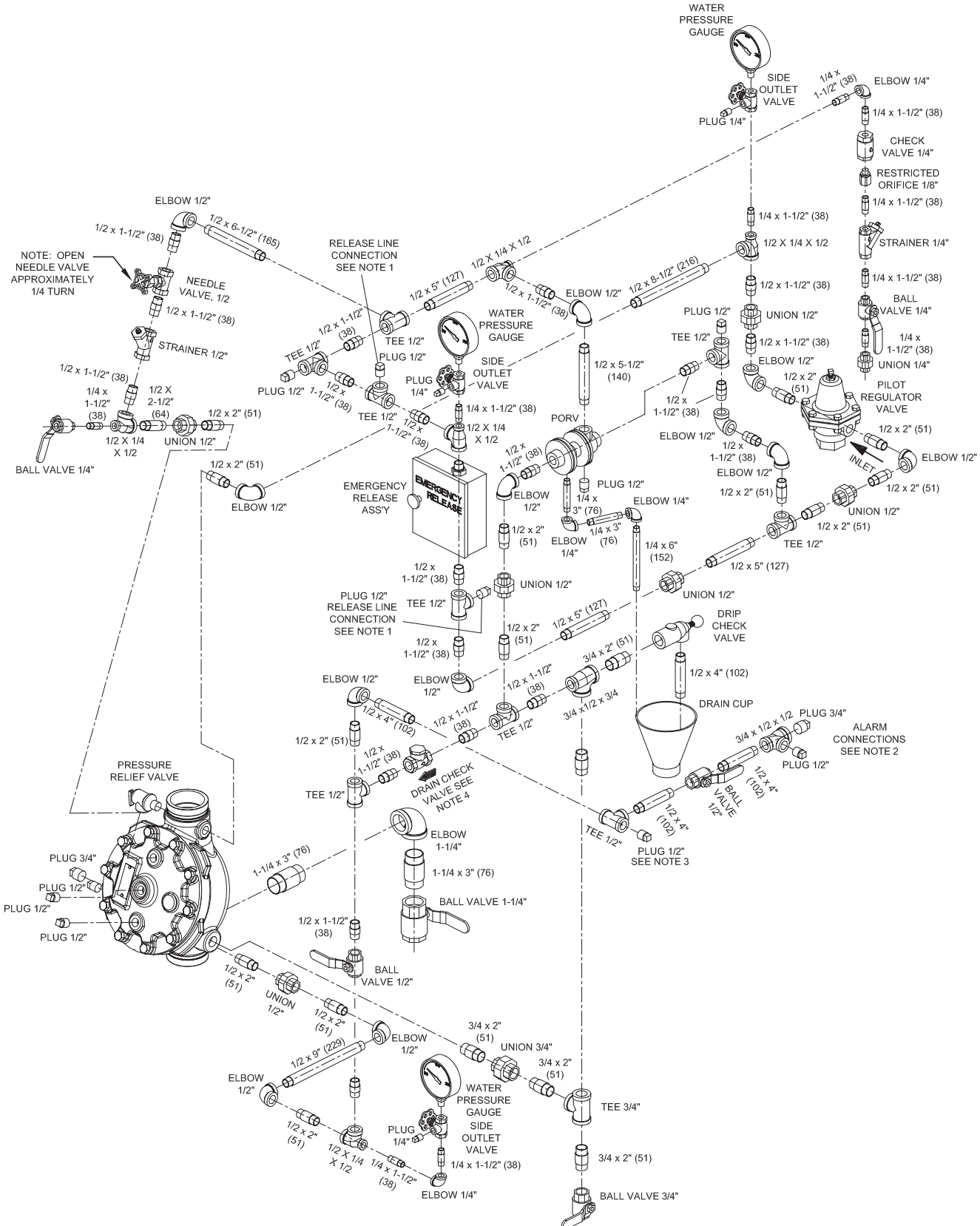



TECHNICAL DATA

PILOT REGULATING DELUGE TRIM

2-1/2" & 3" (DN65 & DN80) MODEL J
VERTICAL FLOW CONTROL VALVE

The Viking Corporation, 210 N Industrial Park Drive, Hastings MI 49058

Telephone: 269-945-9501 Technical Services 877-384-5464 Fax: 269-945-4495 Email: techsvcs@vikingcorp.com

Installation Dimensions

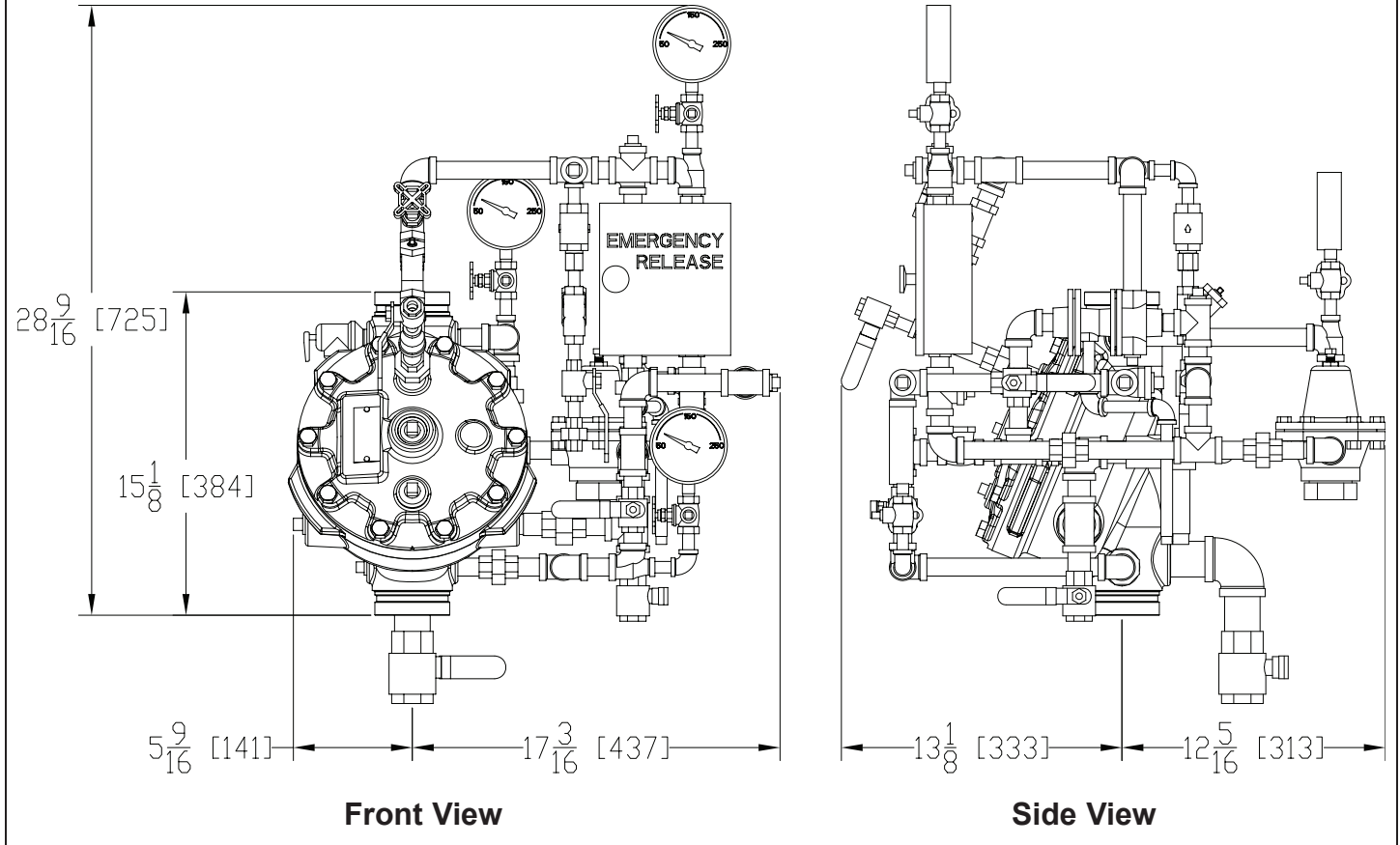

**THIS PAGE
INTENTIONALLY
LEFT BLANK**