



TECHNICAL DATA

IN-LINE BALANCED PRESSURE PROPORTIONER MODEL VLF

The Viking Corporation, 210 N Industrial Park Drive, Hastings MI 49058
 Telephone: 269-945-9501 Technical Services: 877-384-5464 Fax: 269-818-1680 Email: techsvcs@vikingcorp.com
 Visit the Viking website for the latest edition of this technical data page.

1. GENERAL DESCRIPTION

The In-Line Balanced Pressure (ILBP) Proportioner is a foam proportioning device which is used to balance the higher foam concentrate pressure to the lower system water pressure on Pilot Pressure Regulating Systems or Foam Pump Proportioning Systems. The ILBP is particularly useful in providing accurate proportioning at multiple riser locations that are situated remotely from the central foam concentrate storage tank.

Different sizes of ILBP can be installed on the same foam concentrate supply system to ensure the most appropriate size and demand combination is used. The ILBP is tested and approved to work at different pressure and flow rates and will automatically adjust to give accurate proportioning across its working range.

This Technical Data is intended for trained experts.

For further information, please contact the appropriate sales office in **Section 5 Availability** or refer to the technical documentation.

The contents of this publication are subject to modifications without notice.



2. LISTINGS AND APPROVALS

The ILBP is FM Approved and UL Listed as part of a fire extinguishing system combining designated foam concentrates, bladder tanks and discharge devices. It is also required for use with Viking Low Flow Foam Systems.

FM Approved and UL Listed system components can be found at www.approvalguide.com and www.database.UL.com



FM Approved – Low Expansion Foam Systems (FM5130)



UL Listed – Guide GHXV.EX5002 (UL162)

NOTE: Other international approval certificates may be available upon request.

3. TECHNICAL DATA

3.1 Construction Features

- Available in 3" (DN80), 4" (DN100), 6" (DN150), 8" (DN200)
- Brass construction or Nickel Aluminium Bronze construction for superior corrosion protection
- Suitable for Horizontal or Vertical Installation
- Direction of flow indicator on body
- For use with Fresh or Salt Water
- Identification tag plate

3.2 Standard Materials

Table 3.2.1 - Standard Materials	
Nickel Aluminum Bronze Version	
Body & Nozzle	Nickel Aluminum Bronze UNS C95800 — ASTM B148
Orifice	UNS-C36000 or C46400 or C95800
Fittings	Stainless Steel
Spool Assembly	See Table 6.2.2

Continued on next page.



TECHNICAL DATA

IN-LINE BALANCED PRESSURE PROPORTIONER MODEL VLF

The Viking Corporation, 210 N Industrial Park Drive, Hastings MI 49058
 Telephone: 269-945-9501 Technical Services: 877-384-5464 Fax: 269-818-1680 Email: techsvcs@vikingcorp.com
 Visit the Viking website for the latest edition of this technical data page.

Continued from previous page.

Table 3.2.1 - Standard Materials

Brass Version	
Body & Nozzle	Cast Brass UNS C84400 — ASTM B584
Orifice	UNS-C36000
Fittings	Stainless Steel
Spool Assembly	See Table 6.2.2
See notes in Table 3.4.1 for ordering information	

3.3 Standard Design Specifications

Table 3.3.1 - Standard Design Specifications

All Versions	
Design pressure	250 PSI / 17.2 bar (1.7MPa)
Design temperature range	14 °F to 120 °F (-10 °C to 49 °C)*
Operating temperature range	35 °F to 120 °F (1.7 °C to 49 °C)
Minimum operating inlet pressure	30 PSI / 2.1 bar (0.2MPa)
Maximum operating Inlet pressure	150 PSI / 10.3 bar (1.03MPa)
Proportioning range	Refer to Table 3.4.1
Foam inlet pressure	Minimum 15 PSI above system water supply pressure
Maximum static pressure	250 PSI / 17.2 bar (1.7MPa)
*Riser must be installed in an area maintained at or above 40 °F (4.4 °C)	

3.4 Ordering Information

Table 3.4.1 - Ordering information

Connection		Foam Type ⁵	Part Number		Orifice Inches (mm)		FM Approved				UL Listed			
Body Grooved	Foam Inlet Grooved		Nickel Aluminium Bronze ^{2,4}	Brass ³	Inches (mm)		Minimum Flow Rate ¹		Maximum Flow Rate ¹		Minimum Flow Rate		Maximum Flow Rate	
					In	mm	GPM	L/min	GPM	L/min	GPM	L/min	GPM	L/min
3" (88.9mm)	1.5" (48.3 mm)	AFFF 1% S C6	VLF089JAA	F20316A	0.205	5.21	50	189	750	2839	50	189	750	2839
		AFFF 3% S C6	VLF089JAB	F20316B	0.362	9.19	100	378	750	2839	100	378	750	2839
		AFFF 3%M C6	VLF089JAM	F20316M	0.362	9.19	100	378	750	2839	100	378	750	2839
		ARC 3X3 S C6	VLF089JAJ	F20316J	0.392	9.96	200	757	750	2839	200	757	750	2839
4" (114.3mm)	2" (60.3 mm)	AFFF 1% S C6	VLF114JAA	F20317A	0.279	7.09	500	1893	1250	4731	250	947	1250	4731
		AFFF 3% S C6	VLF114JAB	F20317B	0.485	12.32	400	1514	1250	4731	400	1514	1250	4731
		AFFF 3%M C6	VLF114JAM	F20317M	0.485	12.32	400	1514	1250	4731	400	1514	1250	4731
		ARC 3X3 S C6	VLF114JAJ	F20317J	0.472	11.99	450	1703	1250	4731	400	1514	1250	4731
6" (165.1mm)	2" (60.3 mm)	AFFF 1% S C6	VLF165JAA	--	0.358	9.09	500	1893	2300	8706	500	1893	2300	8706
		AFFF 3% S C6	VLF165JAB	--	0.700	17.78	600	2271	2300	8706	500	1893	2280	8629
		AFFF 3%M C6	VLF165JAM	--	0.700	17.78	600	2271	2300	8706	500	1893	2280	8629
		ARC 3X3 S C6	VLF165JAJ	--	0.657	16.69	850	3218	2300	8706	850	3218	2300	8706

NOTES:

¹ Please refer to graphs in section 7.2 for specific flow rate parameters.

² Nickel Aluminium Bronze (NAB) - Standard Offering in Viking EMEA & APAC Territories. Brass available on request with longer delivery.

³ Brass - Standard Offering in Viking Americas Territories. Nickel Aluminium Bronze available on request with longer delivery.

⁴ NAB 219mm with 73mm foam inlet are non standard and could be subject to additional lead time and price.

⁵ All foam types comply with the requirements of the EPA 2010/2015 PFOA Stewardship Program.

Continued on next page.



TECHNICAL DATA

IN-LINE BALANCED PRESSURE PROPORTIONER MODEL VLF

The Viking Corporation, 210 N Industrial Park Drive, Hastings MI 49058
 Telephone: 269-945-9501 Technical Services: 877-384-5464 Fax: 269-818-1680 Email: techsvcs@vikingcorp.com
 Visit the Viking website for the latest edition of this technical data page.

Continued from previous page.

Table 3.4.1 - Ordering information

Connection		Foam Type ⁵	Part Number		Orifice Inches (mm)		FM Approved				UL Listed			
Body Grooved	Foam Inlet Grooved		Nickel Aluminium Bronze ^{2,4}	Brass ³			Minimum Flow Rate ¹		Maximum Flow Rate ¹		Minimum Flow Rate		Maximum Flow Rate	
					In	mm	GPM	L/min	GPM	L/min	GPM	L/min	GPM	L/min
6" (168.3mm)	2" (60.3 mm)	AFFF 1% S C6	VLF168JAA	F20184A	0.358	9.09	500	1893	2300	8706	500	1893	2300	8706
		AFFF 3% S C6	VLF168JAB	F20184B	0.700	17.78	600	2271	2300	8706	500	1893	2280	8629
		AFFF 3%M C6	VLF168JAM	F20184M	0.700	17.78	600	2271	2300	8706	500	1893	2280	8629
		ARC 3X3 S C6	VLF168JAJ	F20184J	0.657	16.69	850	3218	2300	8706	850	3218	2300	8706
8" (219.1mm)	2" (60.3 mm)	AFFF 1% S C6	VLF219JAA	--	0.525	13.34	1550	5867	4500	17033	1300	4920	4500	17033
		AFFF 3% S C6	VLF2196JAB	--	0.975	24.77	1300	4921	4400	16656	1300	4921	4400	16656
		AFFF 3%M C6	VLF2196JAM	--	0.975	24.77	1300	4921	4400	16656	1300	4921	4400	16656
		ARC 3X3 S C6	VLF2196JAJ	--	0.952	24.18	1553	5879	4460	16883	1634	6185	4500	17033
8" (219.1mm)	2" (60.3 mm)	AFFF 1% S C6	VLF2193JAA	F20185A	0.525	13.34	1550	5867	4500	17033	1300	4920	4500	17033
		AFFF 3% S C6	VLF2193JAB	F20185B	0.975	24.77	1300	4921	4400	16656	1300	4921	4400	16656
		AFFF 3%M C6	VLF2193JAM	F20185M	0.975	24.77	1300	4921	4400	16656	1300	4921	4400	16656
		ARC 3X3 S C6	VLF2193JAJ	F20185J	0.952	24.18	1553	5879	4460	16883	1634	6185	4500	17033

NOTES:

¹ Please refer to graphs in section 7.2 for specific flow rate parameters.

² Nickel Aluminium Bronze (NAB) - Standard Offering in Viking EMEA & APAC Territories. Brass available on request with longer delivery.

³ Brass - Standard Offering in Viking Americas Territories. Nickel Aluminium Bronze available on request with longer delivery.

⁴ NAB 219mm with 73mm foam inlet are non standard and could be subject to additional lead time and price.

⁵ All foam types comply with the requirements of the EPA 2010/2015 PFOA Stewardship Program.

INFORMATION

Some of the available options may be not covered by the UL Listing or FM Approval. Please always make reference to the appropriate approval directory or guides or contact Viking for further assistance.

4. SCOPE OF DELIVERY

Ensure that all components are complete and in good condition.

The ILBP is supplied boxed, with a data plate and an integral sized orifice disc specific to its approved/listed concentrate.

The ILBP comes part assembled in the EMEA and APAC ordering territories as detailed in Section 8 and Figure 8.1. In the Americas ordering territory, the ILBP is supplied totally pre-assembled as detailed in Section 6.2. The ILBP is supplied with these main components:

- Balanced spool type balancing valve
- Brass swing check valve
- Duplex gauge which indicates both water pressure (black needle) and foam pressure (red needle)
- Flexible braided sensing lines
- Interconnecting brass nipples as indicated on the detailed drawings

5. AVAILABILITY

Please contact Viking for further information.

The product is available directly from Viking and official distributors only.

EMEA: Viking SA, ZI Haneboesch, L-4562 Differdange / Niederkorn, Tel.: +352 58 37 37 - 1, Fax: +352 58 37 36,

vikinglux@viking-emea.com

Americas: The Viking Corporation, 210 N. Industrial Park Drive, Hastings, Michigan 49058, Toll free phone: (800) 968-9501

APAC: The Viking Corporation (Far East) Pte. Ltd., 69 Tuas View Square, Westlink Techpark, Singapore 637621

Tel: (+65) 6 278 4061, Fax: (+65) 6 278 4609, Email: vikingsingapore@vikingcorp.com

6. PRODUCT VARIANTS

6.1 Options

- Suitable for Viking Foam Concentrate: AFFF 1%S C6 | AFFF 3%S C6 | ARC 3X3S C6 | AFFF 3%M C6
- Nickel Aluminium Bronze UNS C95800 or Brass UNS C84400 (see table 3.4.1)
- Pre-Assembled with Bladder Tank and water/foam pipe work



TECHNICAL DATA

IN-LINE BALANCED PRESSURE PROPORTIONER MODEL VLF

The Viking Corporation, 210 N Industrial Park Drive, Hastings MI 49058
 Telephone: 269-945-9501 Technical Services: 877-384-5464 Fax: 269-818-1680 Email: techsvcs@vikingcorp.com
 Visit the Viking website for the latest edition of this technical data page.

6.2 Dimensions and Equivalent Length

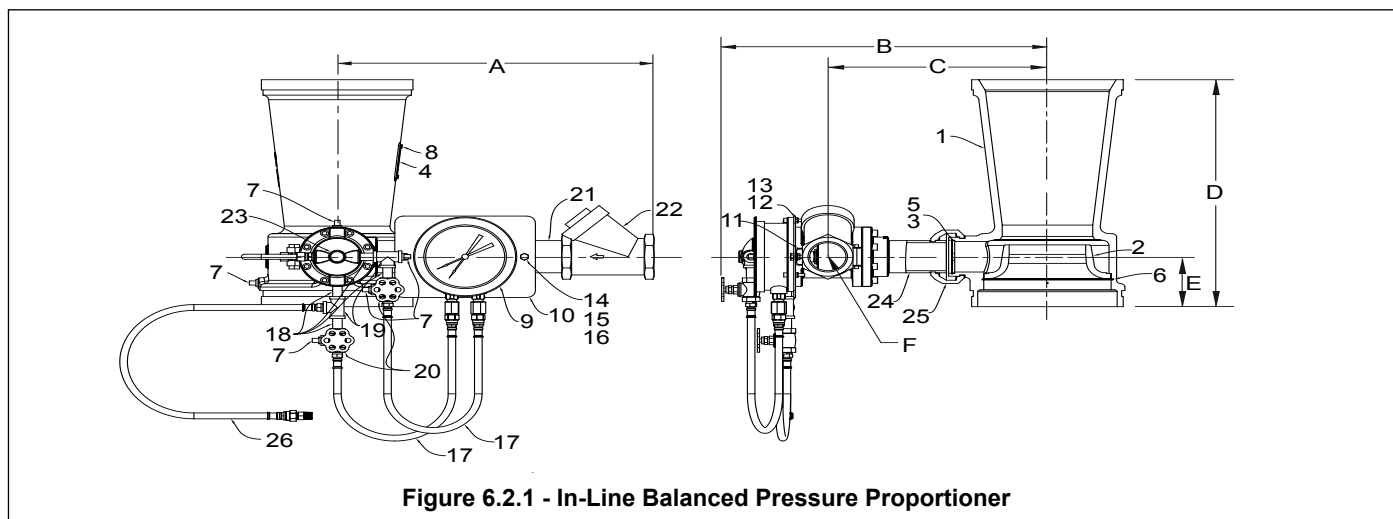

Figure 6.2.1 - In-Line Balanced Pressure Proportioner

Table 6.2.2 - ILBP Assembly Components

Item	Description	Qty	Replacement Part	Item	Description	Qty	Replacement Part
1	Ratio Controller	1	N/A	14	Bolt	2	N/A
2	Nozzle	1	N/A	15	Lock Washer	2	N/A
3	Orifice Plate	1	N/A	16	Nut	2	N/A
4	Data Plate	1	N/A	17	Sensing Line Assembly	2	F09565
5	Retaining Ring	1	N/A	18	Nipple	4	N/A
6	Retaining Ring	1	N/A	19	Tee	2	N/A
7	1/4" Plug	5	14BRPLUG	20	Side Outlet Valve	2	03952A
8	Rivet	2	N/A	21	Nipple	1	N/A
9	Gauge	1	F09646	22	Swing Check Valve (NPT)	1	F09664 (1-1/2") F09665 (2")
10	Mounting Plate	1	N/A	23	Spool Valve	1	N/A
11	Pipe Clamp	1	N/A	24	Nipple	1	N/A
12	Screw	3	N/A	25	Grooved Coupling	1	N/A
13	Nut	3	N/A	26	Sensing Line Assembly	1	F09615

Table 6.2.3 - Equivalent Length, Weight and Dimension Data

Nominal Size	Equivalent Length (friction loss)*		Approximate Weight				Approximate Dimensions											
			NAB Version		Brass Version		A		B		C		D		E		Foam Inlet (F)	
	Feet	Metre	LBS	KGs	LBS	KGs	Inch	mm	Inch	mm	Inch	mm	Inch	mm	Inch	mm	Inch	mm
3" (DN80) Grooved	31	9.45	41.1	18.6	43.5	19.7	17-5/16	440	16	406	9-15/16	252	9-1/4	235	2-15/16	75	1-1/2	40
4" (DN100) Grooved	37	11.28	47.5	21.5	58.5	26.5	18	458	16-3/8	415	10-2/8	261	11	279	3-5/16	84	2	50
6" (DN150) Grooved	88	26.82	64.2	29.1	70.5	32.0	18	458	17-7/16	442	11-3/8	289	15	381	3-5/16	84	2	50
8" (DN200) Grooved	114	34.75	85.7	38.8	96.5	43.8	18	458	18-7/16	468	12-3/8	314	16-3/4	425	3-11/16	94	2	50

* Expressed in equivalent length of schedule 40 pipe based on Hazen & Williams C=120



TECHNICAL DATA

IN-LINE BALANCED PRESSURE PROPORTIONER MODEL VLF

The Viking Corporation, 210 N Industrial Park Drive, Hastings MI 49058
 Telephone: 269-945-9501 Technical Services: 877-384-5464 Fax: 269-818-1680 Email: techsvcs@vikingcorp.com
 Visit the Viking website for the latest edition of this technical data page.

7. PERFORMANCE DATA

7.1 Friction Loss vs Foam Solution Flow

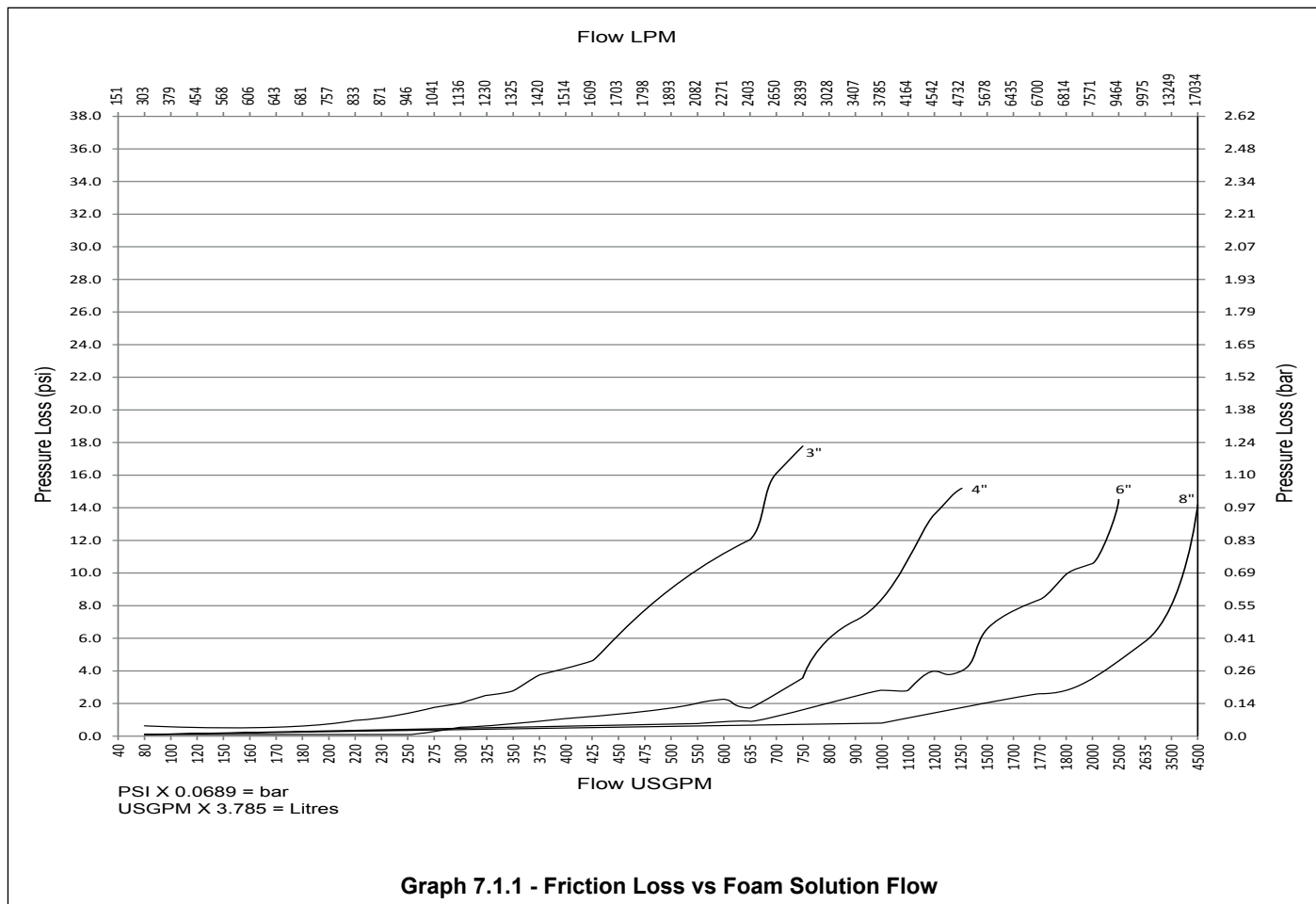



TECHNICAL DATA

IN-LINE BALANCED PRESSURE PROPORTIONER MODEL VLF

The Viking Corporation, 210 N Industrial Park Drive, Hastings MI 49058
 Telephone: 269-945-9501 Technical Services: 877-384-5464 Fax: 269-818-1680 Email: techsvcs@vikingcorp.com
 Visit the Viking website for the latest edition of this technical data page.

7.2 Inlet Pressure vs Foam Solution Flow

The ILBP must be used within the shaded flow and pressure conditions.

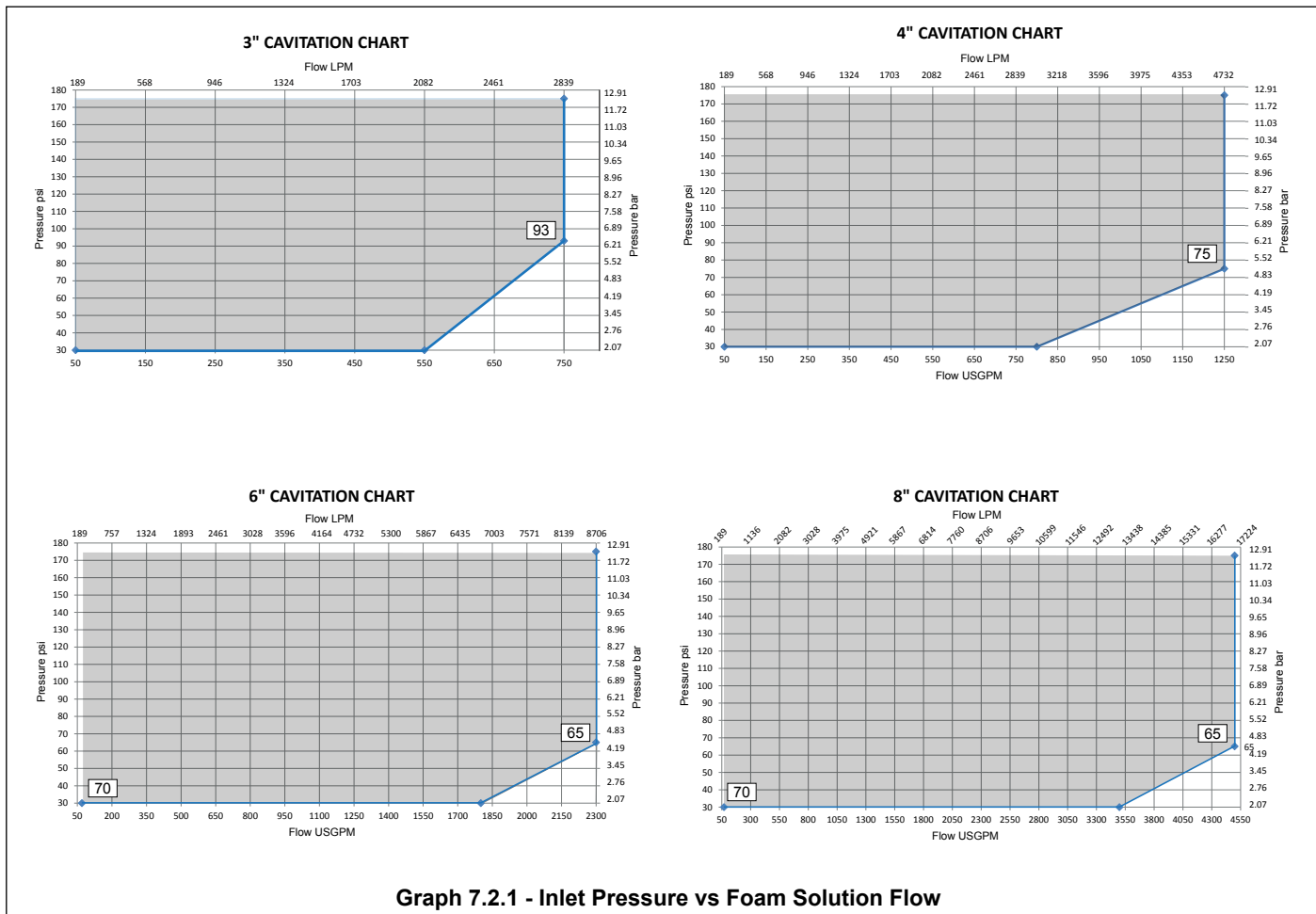



TECHNICAL DATA

IN-LINE BALANCED PRESSURE PROPORTIONER MODEL VLF

The Viking Corporation, 210 N Industrial Park Drive, Hastings MI 49058

Telephone: 269-945-9501 Technical Services: 877-384-5464 Fax: 269-818-1680 Email: techsvcs@vikingcorp.com

Visit the Viking website for the latest edition of this technical data page.

8. INSTALLATION

Refer to appropriate Installation Standards (i.e. NFPA, VdS, LPCB, etc.) and / or applicable FM Global Property Loss Prevention Data Sheets such as 4-12, Foam-Water Sprinkler Systems. Do not alter the piping without consulting a system design representative. Before installing a ratio controller, check the system design drawing to ensure the controller location does not create excessive head pressure or frictional losses.

(Refer to Section 6.2 for identification of ILBP components.)

NOTE: On a Viking Low Flow Bladder Tank System, the water supply flowing pressure at the inlet of the ratio controller and the discharge outlet of the Viking pressure regulating valve must be set at a minimum of 15 PSI lower than the system flowing pressure at the inlet to the Viking pressure regulating valve. (Refer to the website for instructions on how to adjust the outlet pressure on the Viking Pilot Operated Pressure Control Valve, Model A-2 or B-1, under a flowing condition.)

For Foam Pump Systems, the foam concentrate pressure must be a minimum of 15 PSI higher than the system water pressure at the inlet of the ratio controller.

The Viking ILBP is a partially pre-assembled proportioning device, complete with a duplex water and foam pressure gauge, spool valve, concentrate controller, check valve, sensing lines and associated brass piping. It is an integral part of the Viking Low Flow Foam System, and must be installed in accordance with the following instructions.

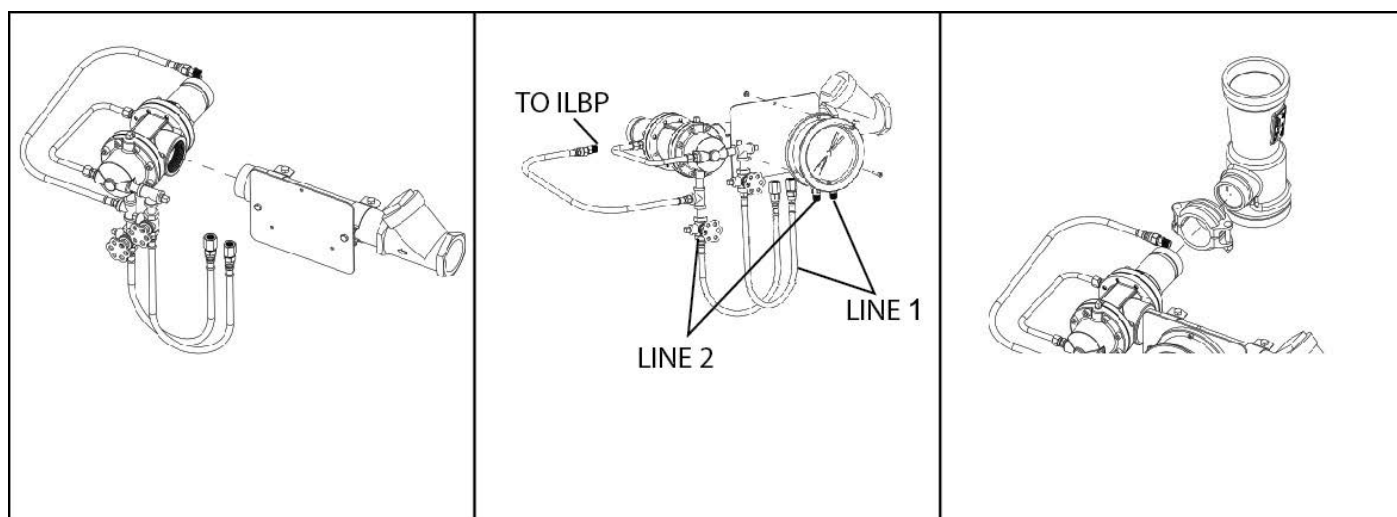

Figure 8.1 - Assembling the Viking ILBP (EMEA and APAC ordering territories only)

The ratio controller section of the ILBP is installed in the riser, on the system side of the Viking Pressure Regulating Valve assembly (on Viking Low Flow Foam Bladder Tank Systems).

The ILBP unit is shipped with the foam pressure sensing line already installed at the end of the spool valve. The water sensing line must be field installed following the schematics above. The foam concentrate supply line from the Viking Halar® coated concentrate valve is then connected to the inlet of the swing check valve. Refer to the appropriate Viking technical data pages for instructions as to completing the system installation and testing of the Low Flow Foam System or foam pump system.

- The ILBP (ratio controller) must be installed with the arrow pointing in the direction of the water flow
- The ILBP (ratio controller) can be installed in the vertical or horizontal position
- The balancing spool valve must always lie horizontally (as shown below)
- The foam concentrate supply line diameter may need to be increased above the foam inlet size ("F" Fig 6.2.1) due to friction loss in piping from the riser back to the foam source
- In Deluge and Preaction systems a removable section of pipe should be installed between the Concentrate Control Valve and ILBP foam inlet to allow the flushing of foam concentrate after system activation or testing
- A foam concentrate supply pressure gauge is recommended adjacent to foam inlet of the CCV
- If installed in a horizontal header, the check valve ("22" Fig 6.2.1) must be oriented so that the clapper is perpendicular to the floor and access hole is facing up (as shown below)
- Straight piping equal to a minimum of five (5) pipe diameters should be installed before and after the ILBP (ratio controller) to help ensure proportioning accuracy



TECHNICAL DATA

IN-LINE BALANCED PRESSURE PROPORTIONER MODEL VLF

The Viking Corporation, 210 N Industrial Park Drive, Hastings MI 49058
 Telephone: 269-945-9501 Technical Services: 877-384-5464 Fax: 269-818-1680 Email: techsvcs@vikingcorp.com
 Visit the Viking website for the latest edition of this technical data page.

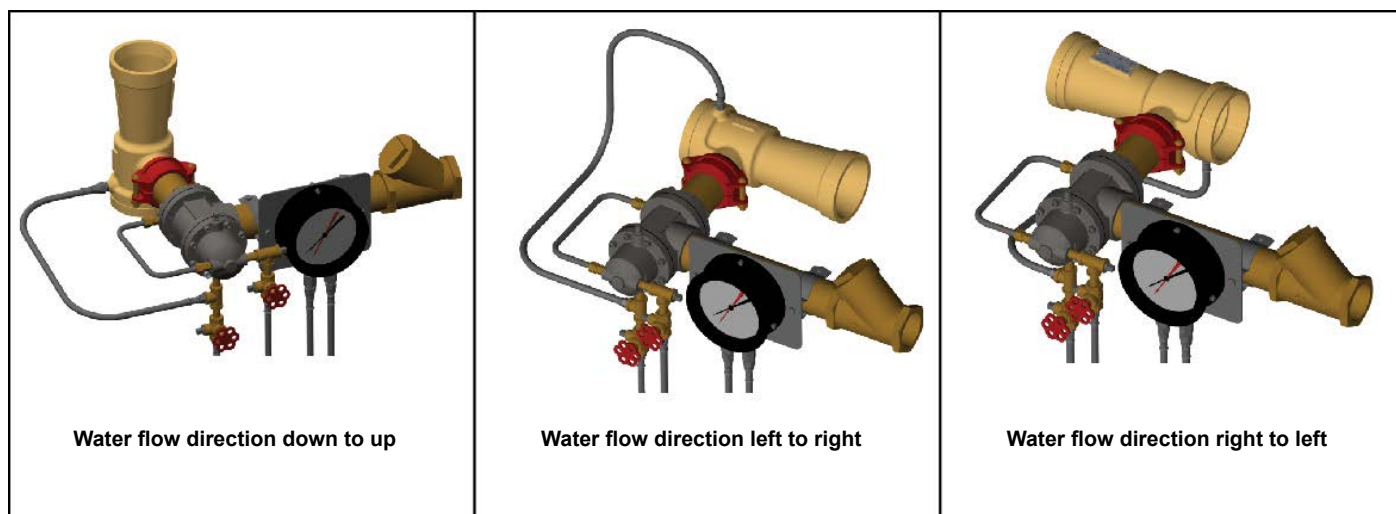

Figure 8.2 - Typical Proportioning Device Orientations

9. OPERATION

The system water pressure, under a water flow condition, must be at least 15 PSI lower than the foam concentrate pressure at the ratio controller (1).

- The reduction in system water pressure for a Viking Low Flow Bladder Tank System is accomplished by the use of the Viking Pilot Pressure Regulating Valve, which is also a component of the Viking Low Flow Foam System.
- For foam pump systems, the foam pressure at the ILBP must be at least 15 PSI higher than the water pressure.

Upon system actuation, water begins to flow through the piping network, including the ILBP.

The ILBP water sensing line (connected upstream of the ratio controller by installer) and foam sensing line are connected to upper and lower side of internal hydraulic piston. The piston is integrally attached to the balanced spool of the pressure balancing valve.

As the foam concentrate discharge pressure from the spool valve increases above the inlet water pressure, the spool valve closes over the discharge ports of the balancing valve until the foam pressure equals water pressure. This allows the correct balanced pressure foam concentrate to flow through the metering orifice of the ratio controller.

As the discharge foam concentrate pressure is lowered below the water supply pressure due to increase in flow and metering pressure drop caused by the venturi of the ratio controller, the piston and spool valve open to allow more flow as required. When the foam concentrate inlet pressure is equal to the water inlet pressure of the ratio controller, the proper mixture of foam solution is developed at the minimum and maximum flow rates shown for each size ILBP and foam concentrate being applied.

Due to the foam concentrate pressure being supplied at a higher pressure than the water supply, a positive injection of foam concentrate occurs. This will cause rich foam solution below the minimum flow rates shown or at the initial fire condition where a small discharge flow rate occurs where only a few sprinklers have opened. As additional sprinklers operate and flow increases, the metering pressure drop across the ratio controller's venturi matches the sized foam concentrate metering orifice thus producing the desired solution of water and foam mixture as indicated in **Table 3.4.1**.

10. GUARANTEE

For details of warranty, refer to Viking's current list price schedule or contact Viking directly.



TECHNICAL DATA

IN-LINE BALANCED PRESSURE PROPORTIONER MODEL VLF

The Viking Corporation, 210 N Industrial Park Drive, Hastings MI 49058
 Telephone: 269-945-9501 Technical Services: 877-384-5464 Fax: 269-818-1680 Email: techsvcs@vikingcorp.com
 Visit the Viking website for the latest edition of this technical data page.

11. INSPECTION, TESTS AND MAINTENANCE

Refer to respective requirements, according to the relevant standards for Inspection, Testing and Maintenance.
 If applicable, refer to FM Global Property Loss Prevention Datasheet 4-12 for specific test and commissioning criteria.
 In addition, the "Authority Having Jurisdiction" (AHJ) may have additional maintenance, testing and inspection requirements that must be followed.

NOTICE

The owner is responsible for maintaining the fire protection system and devices in proper operating condition. The Pilot Operated Pressure Control Valve must be kept from freezing conditions and physical damage that could impair its operation.

⚠ WARNING

Any system maintenance or testing that involves placing a control valve or detection system out of service may eliminate the fire protection of that system. Prior to proceeding, notify all Authorities Having Jurisdiction. Consideration should be given to employment of a fire patrol in the affected area.

12. DISPOSAL



At end of use the product described here should be disposed of via the national recycling system.

13. ACCESSORIES AND SPARE PARTS

See Table 6.2.2

14. DECLARATION OF CONFORMITY

If required, contact the appropriate sales office in **Section 5 Availability** for further assistance.