

Application

Designed for installation on potable water lines to protect against both backsiphonage and backpressure of polluted water into the potable water supply. The Model 350A shall provide protection where a potential health hazard does not exist. Ideal for use where Lead-Free* valves are required.

Standards Compliance (Horizontal & Vertical)

- ASSE® Listed 1015
- AWWA Compliant C510 (with gates only), and C550
- IAPMO® Listed
- Certified to NSF/ANSI 372* by IAPMO R&T
- CSA® Certified
- UL® Classified
- C-UL® Classified
- FM® Approved
- NYC MEA 220-04-M Vol 2 (2 1/2" - 8")
- Approved by the Foundation for Cross Connection Control and Hydraulic Research at the University of Southern California
- NSF® Listed-Standard 61, Annex G*

* (0.25% MAX. WEIGHTED AVERAGE LEAD CONTENT)

Materials

Main valve body	Ductile Iron ASTM A 536 Grade 4
Access covers	Ductile Iron ASTM A 536 Grade 4
Coatings	FDA Approved electrostatic epoxy finish
Internals	Stainless steel, 300 Series NORYL™, NSF Listed
Fasteners & springs	Stainless Steel, 300 Series
Seal ring	EPDM (FDA approved)
O-ring	Buna Nitrile (FDA approved)

Features

Sizes:	2 1/2", 3", 4", 6", 8", 10"
Maximum working water pressure	175 PSI
Maximum working water temperature	140°F
Hydrostatic test pressure	350 PSI
End connections	
(Grooved for steel pipe)	AWWA C606
(Flanged)	ANSI B16.1 Class 125

Dimensions & Weights (do not include pkg.)

MODEL 350A SIZE	WEIGHT														
	LESS SHUTOFF VALVES		NRS GATE VALVES FLANGED		NRS GATE VALVES GROOVED		OSY GATE VALVES FLANGED		OSY GATE VALVES GROOVED		BUTTERFLY VALVES FLANGED		BUTTERFLY VALVES GROOVED		
	in.	mm	lbs.	kg	lbs.	kg	lbs.	kg	lbs.	kg	lbs.	kg	lbs.	kg	
2 1/2	65	90	41	184	83	176	80	192	87	184	83	142	65	132	60
3	80	89	40	204	93	194	88	210	95	200	91	147	66	133	61
4	100	76	34	220	100	194	88	230	104	204	93	147	66	124	56
6	150	126	57	346	157	316	143	362	164	332	151	231	105	200	91
8	200	286	130	738	335	738	335	762	346	738	335	476	216	430	195
10	250	339	154	966	438	844	383	1024	464	902	409	613	278	555	252

MODEL 350A SIZE	DIMENSION (approximate)																								
	A		A WITH BUTTERFLY VALVES		B LESS GATE VALVES		C		D		E OS&Y OPEN		E OS&Y CLOSED		E NRS GATE		E WITH BUTTERFLY VALVES		F		G WITH GATE VALVES		G WITH BUTTERFLY VALVES		
	in.	mm	in.	mm	in.	mm	in.	mm	in.	mm	in.	mm	in.	mm	in.	mm	in.	mm	in.	mm	in.	mm	in.	mm	
2 1/2	65	35 1/8	892	32 1/8	816	20 1/8	511	4 1/2	114	7 1/4	184	17 3/4	451	15 3/8	391	11 1/2	292	8 1/4	210	6	152	45 1/4	1149	42 1/4	1073
3	80	36 1/8	918	33	838	20 1/8	511	4 1/2	114	7 1/4	184	20 1/4	514	17	432	12 3/4	324	8 1/2	216	6	152	46 7/8	1191	43 3/4	1111
4	100	38 1/4	972	33 1/4	845	19 7/8	505	4 1/2	114	8	203	22 1/2	572	18 1/4	464	14 1/2	368	9	229	6	152	53 3/8	1356	48 3/8	1229
6	150	47 1/4	1200	40 1/4	1022	25 7/8	657	5 1/2	140	10	254	30 1/2	775	24 1/4	616	18	457	10 1/4	260	7	178	65 3/8	1661	58 3/8	1483
8	200	62	1575	55	1397	38 1/2	978	10	254	11	279	37	940	28 1/2	724	21 1/8	537	12	305	8 1/2	216	86 3/8	2194	79 3/8	2016
10	250	64 5/8	1641	58 1/2	1486	38 1/2	978	10	254	12	305	45 5/8	1159	34 3/4	883	24 3/4	629	13	330	8 1/2	216	94 3/8	2397	88 1/4	2242

Attention: Model 350A (grooved body) & Model 350 (flange body) have different lay lengths.



(with OSY gates)

(with BG valves)



Options

(Suffixes can be combined)

- with flanged end NRS gate valves (standard)
- FSC - with epoxy coated wye type strainer (flanged only)
- G - with grooved end connections
- GF - with grooved inlet connection and flanged outlet connection
- FG - with flanged inlet connection and grooved outlet connection
- L - less shut-off valves (grooved body connections)
- OSY - with flanged end OS&Y gate valves
- OSYG - with grooved end OS&Y gate valves
- PI - with Post Indicator Gate Valves
- BG - with grooved end butterfly valves with integral supervisory switches
- BF - with flanged end butterfly valves with integral supervisory switches

Accessories

- Repair kit (rubber only)
- Thermal expansion tank (Model XT)
- OS & Y Gate valve tamper switch (OSY-40)

MODEL 350A with OSY & FSC option

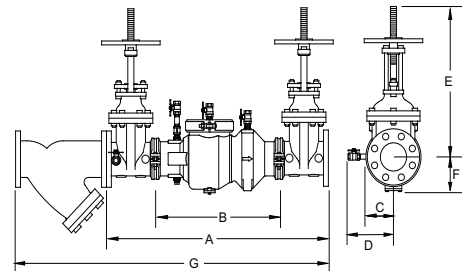

MODEL 350A with BG option

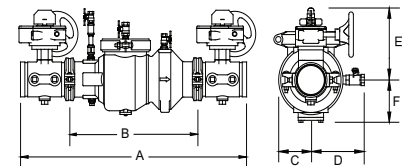

MODEL 350A 2 1/2", 3" & 4" (STANDARD & METRIC)

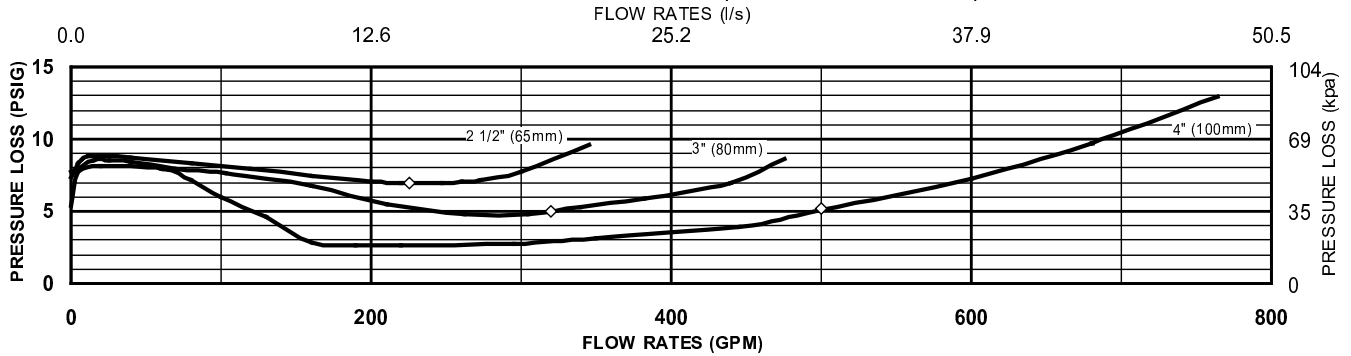

MODEL 350A 6", 8" & 10" (STANDARD & METRIC)

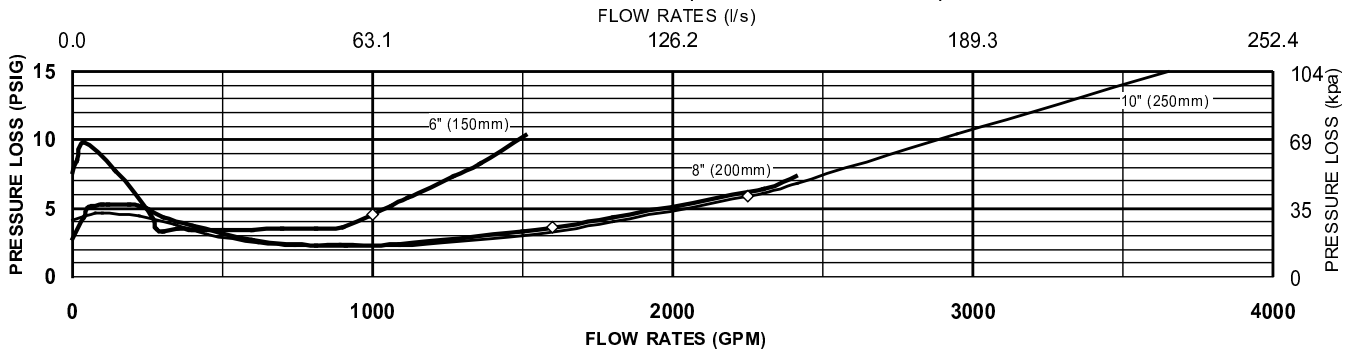

Typical Installation

Local codes shall govern installation requirements. Unless otherwise specified, the assembly shall be mounted at a minimum of 12" (305mm) and a maximum of 30" (762mm) above adequate drains with sufficient side clearance for testing and maintenance. The installation shall be made so that no part of the unit can be submerged.

Capacity thru Schedule 40 Pipe (GPM)				
Pipe size	5 ft/sec	7.5 ft/sec	10 ft/sec	15 ft/sec
2 1/2"	75	112	149	224
3"	115	173	230	346
4"	198	298	397	595
6"	450	675	900	1351
8"	780	1169	1559	2339
10"	1229	1843	2458	3687
12"	1763	2644	3525	5288

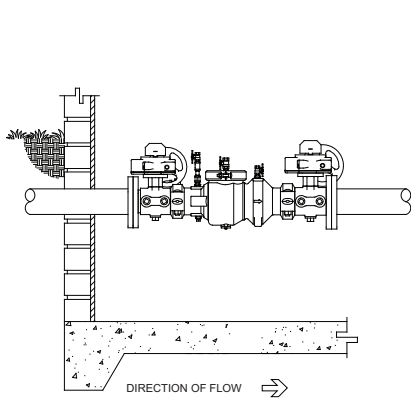

**INDOOR INSTALLATION
MODEL 350ABF**

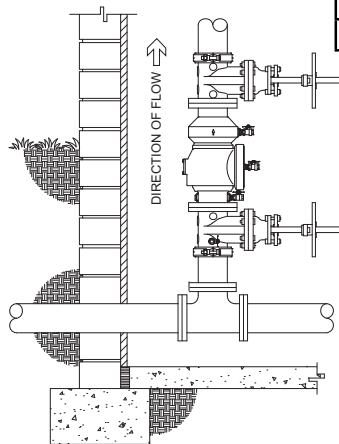

**INDOOR INSTALLATION
(VERT.) MODEL 350A**

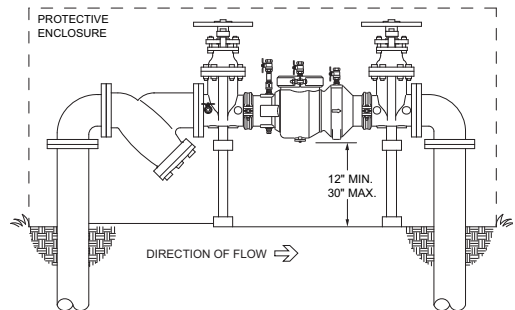

**OUTDOOR INSTALLATION
MODEL 350AFS**

Specifications

The Double Check Backflow Prevention Assembly shall be certified to NSF/ANSI 372, ASSE® Listed 1015, and supplied with full port gate valves. The main body and access cover shall be epoxy coated ductile iron (ASTM A 536 Grade 4), the seat ring and check valve shall be NORRYL™, the stem shall be stainless steel (ASTM A 276) and the seat disc elastomers shall be EPDM. The checks shall be accessible for maintenance without removing the device from the line. The Double Check Backflow Prevention Assembly shall be a ZURN WILKINS Model 350A.