

**SPECIFICATION SHEET** **FEBCO®**

# MasterSeries® 876V

## Double Check Detector Assemblies

**MASTER series®**

**Size: 2½" - 10" (65mm - 250mm)**

The FEBCO MasterSeries® 876V Double Check Detector Assemblies are designed for use in non-health hazard fire sprinkler systems.

Standard orientation is inlet flow vertical up, outlet flow vertical down. Vertical orientation is inlet and outlet flow vertical up.

**Materials**

Main Valve Body:	Ductile iron Grade 65-45-12
Coating:	Fusion epoxy coated internal and external AWWA C550-90
Shutoff Valves:	OS&Y resilient wedge gate valves AWWA C509
Trim:	Bronze
Elastomer Discs:	EPDM
Spring:	Stainless steel

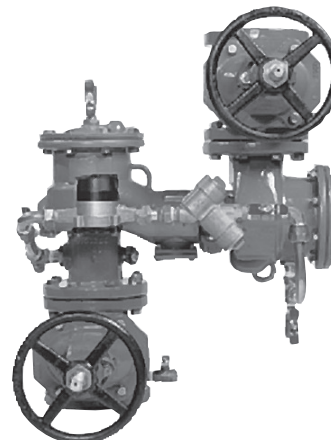

**MODEL 876V DOUBLE CHECK DETECTOR ASSEMBLY**  
(Shown in vertical orientation)

U.S. Patent No. 4,989,635 • U.S. Patent No. 5,107,888  
U.S. Patent No. 5,385,166 • U.S. Patent No. 5,226,441  
U.S. Patent No. 5,392,803 • U.S. Patent No. 5,503,176

**Models**

- Valve Setter with MJ x MJ, MJ x FL, or FL x FL ends
- End Connections – Flanged ANSI B16.1 Class 125

**Pressure – Temperature**

Maximum Working Pressure:	175psi (12.1 bar)
Hydrostatic Test Press:	350psi (24.1 bar)
Temperature Range:	32°F to 140°F (0°C to 60°C)

**Approvals – Standards**

- ANSI/AWWA (C510)
- Approved by the Foundation for Cross-Connection Control and Hydraulic Research at the University of Southern California.



\* Less gate not FM approved. Less gate not UL Classified unless installed with UL Listed gate valves

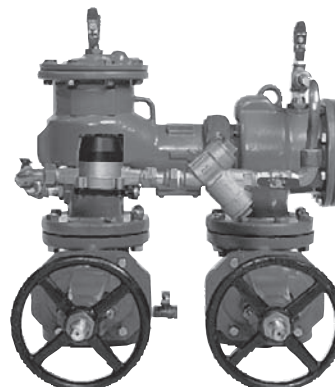

**MODEL 876V DOUBLE CHECK DETECTOR ASSEMBLY**  
(Shown in standard orientation)

Job Name \_\_\_\_\_

Job Location \_\_\_\_\_

Engineer \_\_\_\_\_

Approval \_\_\_\_\_

Contractor \_\_\_\_\_

Approval \_\_\_\_\_

Contractor's P.O. No. \_\_\_\_\_

Representative \_\_\_\_\_

FEBCO product specifications in U.S. customary units and metric are approximate and are provided for reference only. For precise measurements, please contact FEBCO. FEBCO reserves the right to change or modify product design, construction, specifications, or materials without prior notice and without incurring any obligation to make such changes and modifications on FEBCO products previously or subsequently sold.

# Model 876V / Materials of Construction

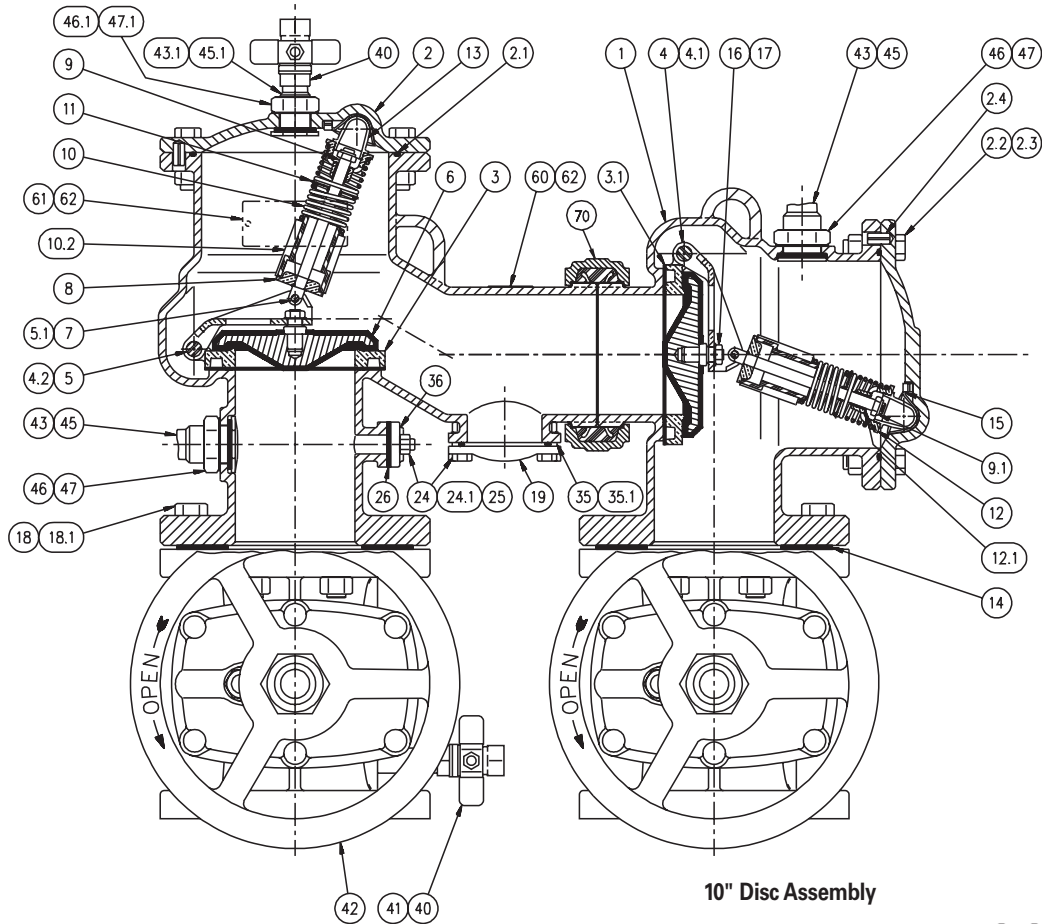

10" Disc Assembly

#	DESCRIPTION	MATERIAL	#	DESCRIPTION	MATERIAL	#	DESCRIPTION	MATERIAL
1	Body	A536 GR 65-45-12	8	Lower Sprg. Retainer	B584 Alloy C83600	350-ring		EPDM ASTM D1999
2	Cover	A536 GR 65-45-12	9	Spring Stem	304SS	35.1	Back Up Ring	Acetal Resin
2.1	O-ring	EPDM ASTM D2000	9.1	Elastic Stop Jam Nut	18-8 SS	36	Cover	B584 Alloy C83600
2.2	Cap Screw	Plated Steel	10	Spring	A313 Type 631 SS	40	Ball Valve	B584 Alloy C83600
2.3	Hex Nut	Plated Steel	10.2	Spring Shim	Acetal Resin	41	Nipple	Brass
2.5	Cover (w/o holes)	A536 GR 65-45-12	10.3	Spring Shim	Acetal Resin	42	Gate Valve (OS&Y)	AWWA C509
3	Seat Ring	B524 Alloy C83600	11	Spring Guide	B130 Alloy C22000	43	Bulkhead Fitting	B584 Alloy C83600
3.1	Gasket	EPDM ASTM D2000	12	Upper Sprg. Retainer	B584 Alloy C83600	43.1	Bulkhead Fitting	B584 Alloy C83600
4	Arm	B584 Alloy C83600	12.1	Bushing Sprg. Stern	Acetal Resin	44	Bulkhead Fitting	B584 Alloy C83600
4.1	Bushing-Swing Pin	Acetal Resin	13	Pivot Bearing	B585 Alloy C83600	45	Gasket	EPDM ASTM D2000
4.2	Swing Pin	304 SS	14	Flange Gasket	Rubber/Fabric	45.1	Gasket	EPDM ASTM D2001
5	Retaining Clip	302 SS	15	Bearing Socket	Acetal Resin	46	Washer	B36 Alloy 260
5.1	Retaining Clip	302 SS	16	Hex Jam Nut	18-8 SS	46.1	Washer	B36 Alloy 260
6	Check Disk (2 1/2" - 8")	EPDM Coated GR, 45 Ductile Iron w/ type 304 SS	17	Washer	302 SS	47	Nut	B584 Alloy C83601
	Seat Disc (10")	Silicone ASTM D2000	18	Flange Nut	Plated Steel	47.1	Nut	B584 Alloy C83602
6.1*	Disc Holder (10")	ASTM A743 304 SS	18.1	Flange Nut	Plated Steel	60	Identification Plate	B36 Alloy C26000
6.2*	Disc Retainer (10")	ASTM A743 304 SS	19	Cover	A36 Stl. Epoxy Coated	61	Identification Plate	B36 Alloy C26000
6.3*	Capscrew (10")	18-8 SS	24	Bolt	Plated Steel	62	Drive Screw	Stainless Steel
7	Load Pin	304SS	24.1	Washer	Plated Steel	70	Clamp 876V Only	AWWA C606
			25	Nut	Plated Steel			
			26	Gasket	EPDM ASTM D2000			

**Model 876V**  
Standard Orientation

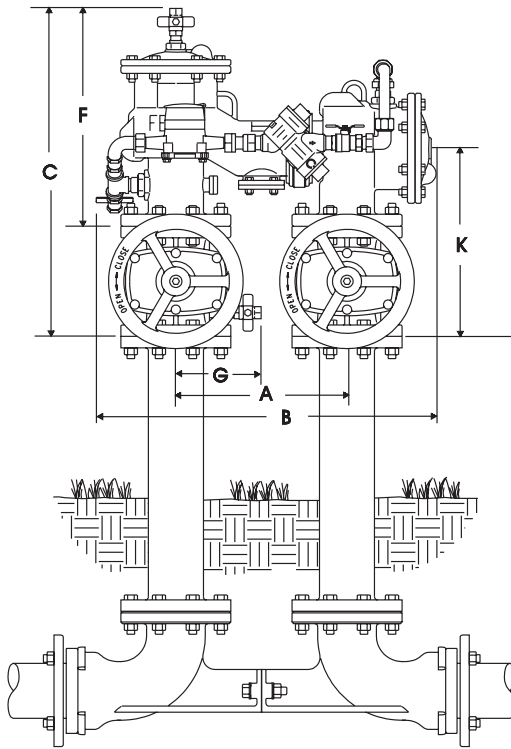

**Model 876V**  
Vertical Orientation

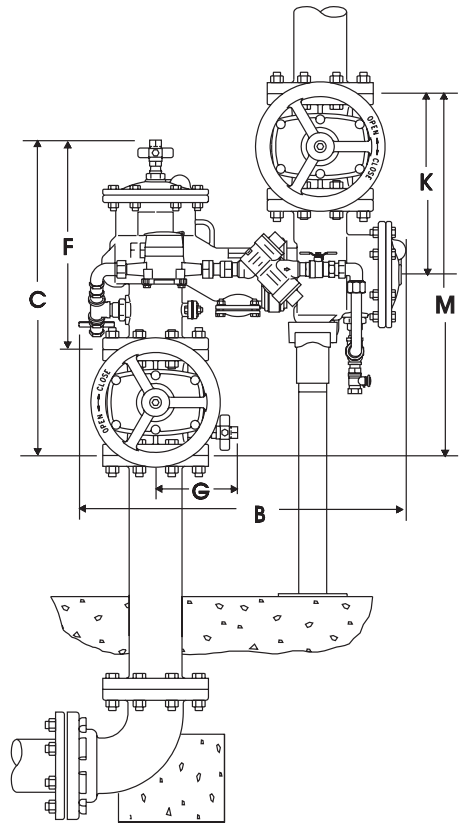

**Note:** The Series 876V is shipped in the standard (N-Shape) orientation as shown above.

**OS&Y Side View**

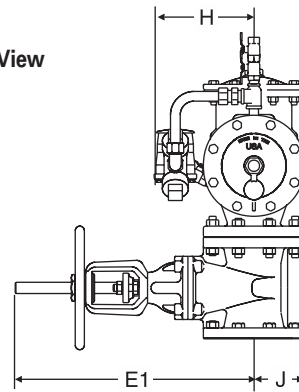

**Dimensions – Weights**

**Size: 2½" - 10" (65 - 250mm)**

SIZE (DN)		DIMENSIONS														WEIGHT							
		A		B		C		E1 OS&Y*		F		G		H		J		K		M		OS&Y	
in.	mm	in.	mm	in.	mm	in.	mm	in.	mm	in.	mm	in.	mm	in.	mm	in.	mm	in.	mm	in.	mm	lbs.	kg.
2½	65	12½	318	25¾	654	24¼	616	16¾	416	16¾	422	6¼	159	11½	292	3½	89	13¾	346	27¼	692	230	104
3	80	12½	318	25¾	654	24¾	629	22¼	565	16¾	422	6¼	159	11½	292	3¾	95	14½	359	28¼	718	300	136
4	100	14	356	27⅞	708	26¾	680	23¼	591	17¾	451	7	178	13	330	4½	114	15½	394	31	787	330	150
6	150	16	406	32¼	819	32¼	819	30⅞	765	21⅞	548	8	203	13	330	5½	140	18⅞	473	37¼	946	520	236
8	200	18½	470	37½	953	36¾	924	37¾	959	24⅞	632	9¼	235	14½	368	6¾	172	20¾	527	41½	1054	860	390
10	250	21	533	42½	1080	40¾	1035	48	1219	27½	699	10	254	15	381	8	203	24	610	48	1219	1460	662

\*OS&Y OPEN

Weights do not include risers or optional valve setter.  
 Note: Dimensions shown are nominal. Allowances must be made for normal manufacturing tolerances.  
 Refer to Specification Sheet ES-F-611, ES-F-611 Flange and ES-F-611MJ for details on valve setter.

# Typical Installation

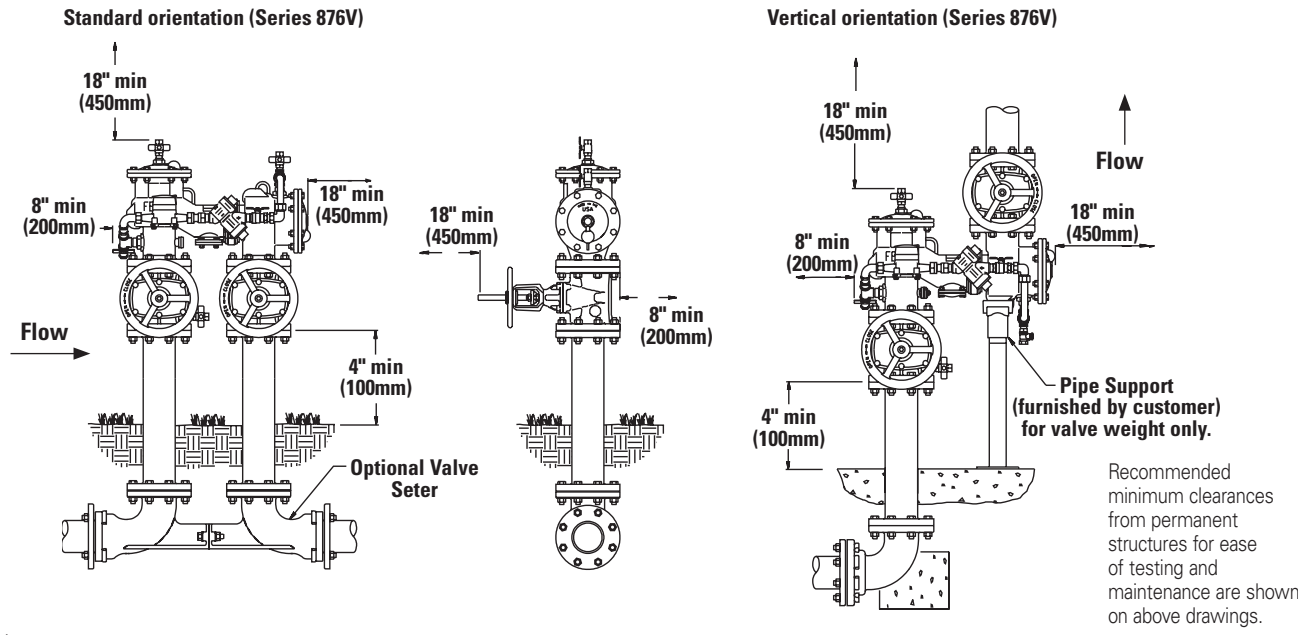

# Capacity

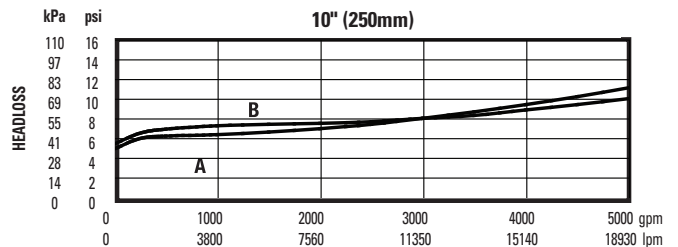
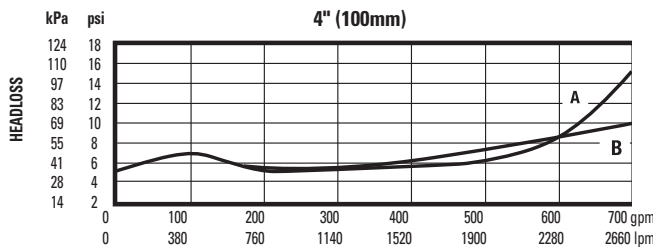
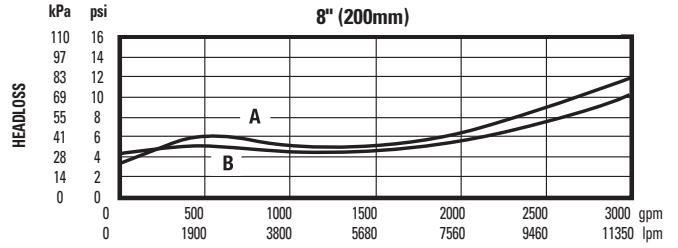
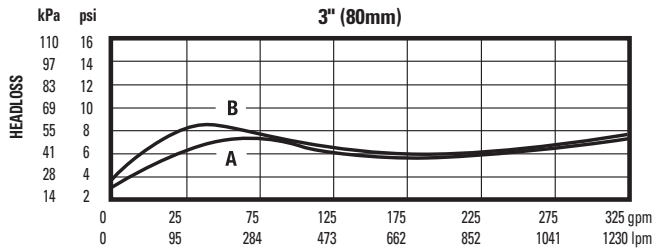
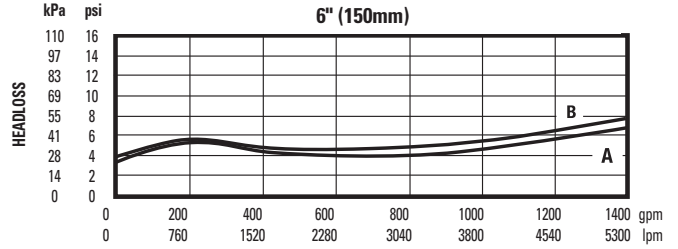
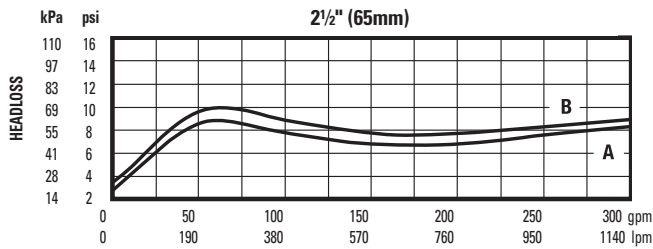

A-Vertical orientation  
B-Standard orientation

The 6" and 10" flow curves (B-standard orientation) include the FEBCO Valve Seter Series 611.



**MASTER series**

**ISO 9001-2000 CERTIFIED**