

Fig. 1000 - "Fast Clamp" Sway Brace Attachment

Component of State of California OSHPD Approved Seismic Restraints System

Size Range — Pipe size to be braced: 1" thru 6" Schedule 10 thru 40 IPS.* Pipe size used for bracing: 1" and 1¼" Schedule 40 IPS.

* Additionally (UL) approved for use to brace Schedule 7 sprinkler pipe up to 4" (maximum horizontal design load 655 lbs.) Torque requirement 6 — 8 ft. lbs.

Material — Carbon Steel

Function — For bracing pipe against sway and seismic disturbance. The pipe attachment component of a sway brace system: Fig. 1000 is used in conjunction with a TOLCO Fig. 900 Series Fitting and joined together with bracing pipe per NFPA 13* or TOLCO OSHPD Approved Seismic Manual, forming a complete sway brace assembly.

Features — Field adjustable, making critical pre-engineering of bracing pipe unnecessary. Unique design requires no threading of bracing pipe. Can be used as a component of a 4-way riser brace. Can be used as longitudinal brace with Fig. 907. Comes assembled and individually packaged with illustrated installation instructions — sizes are clearly marked. Steel leaf spring insert provided to assure installer and inspector necessary minimum torque has been achieved.

Installation — The Fig. 1000 is the "braced pipe" attachment component of a lateral sway brace assembly. It is intended to be combined with the "bracing pipe" and TOLCO structural attachment component, Fig. 980, 910 or 909 to form a complete bracing assembly. Follow NFPA 13 and/or OSHPD guidelines.

To Install — Place the Fig. 1000 over the pipe to be braced, insert bracing pipe through opening leaving a minimum of 1" extension. Brace pipe can be installed on top or bottom of pipe to be braced. Tighten hex nuts until leaf spring is flat. It is recommended that the brace angle be adjusted before hex nuts are fully tightened.

Approvals — Underwriters Laboratories Listed in the USA (UL) and Canada (cUL). Approved by Factory Mutual Engineering (FM). Included in our Seismic Restraints Catalog approved by the State of California Office of Statewide Health Planning and Development (OSHPD). For additional load, spacing and placement information relating to OSHPD projects, please refer to the TOLCO Seismic Restraint Systems Guidelines.

Application Note — Position Fast Clamp and tighten two hex nuts until leaf spring flattens. A minimum of 1" pipe extension beyond the Fig. 1000 is recommended.

Finish — Plain

Note — Available in Electro-Galvanized and HDG finish or Stainless Steel materials.

Order By — Order first by pipe size to be braced, followed by pipe size used for bracing, figure number and finish.

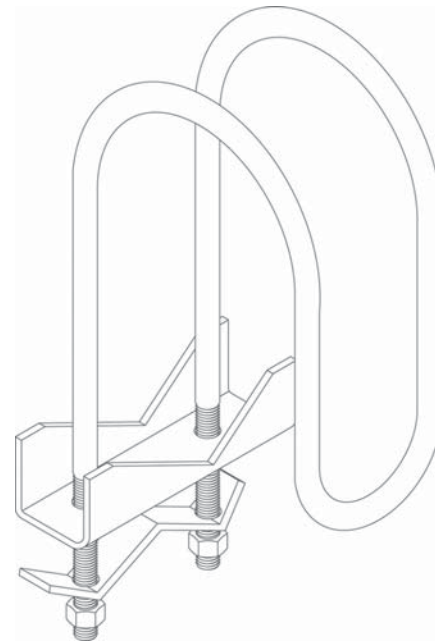

<p>Maximum Design Load 1" thru 4" pipe size — 2015 lbs. 6" size — 1265 lbs.</p>
<p>FM Approved Design Loads* 1" - 2½" - 600 lbs. 3" - 4" - 700 lbs.</p>

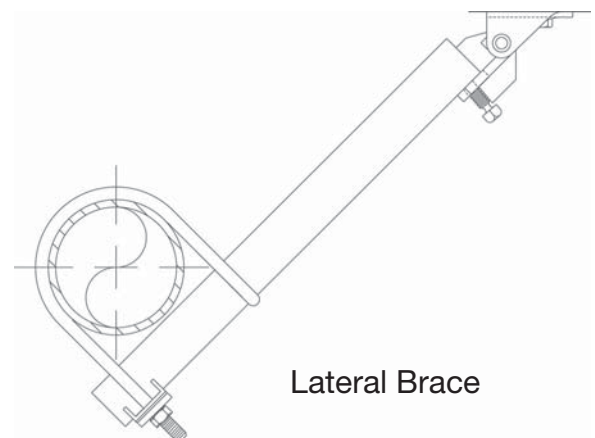

Lateral Brace

TOLCO® brand bracing components are designed to be compatible **ONLY** with other TOLCO® brand bracing components, resulting in a Listed seismic bracing assembly. **DISCLAIMER** — NIBCO does **NOT** warrant against the failure of TOLCO® brand bracing components, in the instance that such TOLCO® brand bracing components are used in combination with products, parts or systems which are not manufactured or sold under the TOLCO® brand. NIBCO shall **NOT** be liable under any circumstance for any direct or indirect, incidental or consequential damages of any kind, including but not limited to loss of business or profit, where non-TOLCO brand bracing components have been, or are used.