

Fig. 120 - "U" Hanger

Size Range — Size 3/4" thru 8" pipe

Material — Carbon Steel

Function — Used to support piping from wood beams where no contraction is expected. Used extensively in automatic fire sprinkler systems.

Approvals — Meets or exceeds the requirements of National Fire Protection Association (NFPA), Pamphlet 13. Underwriters Laboratories Listed in the USA (UL) and Canada (cUL). Included in our Seismic Restraints Catalog approved by the State of California Office of Statewide Health Planning and Development (OSHPD). For additional load, spacing and placement information relating to OSHPD projects, please refer to the TOLCO Seismic Restraint Systems Guidelines.

Maximum Temperature — 750°F

Finish — Plain

Note — Available in Electro-Galvanized and HDG finish or Stainless Steel materials.

Order By — Figure number, pipe size, length and finish

Component of State of California OSHPD Approved Seismic Restraints System

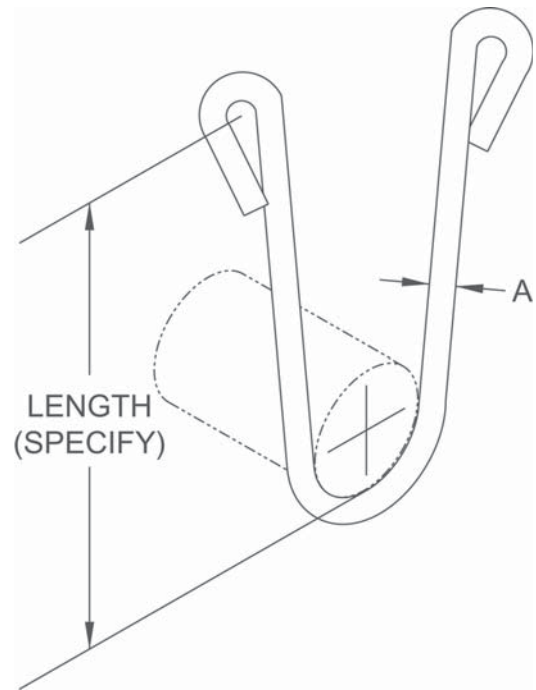

Dimensions			
Pipe Size	A	Fastener Size	Max Rec. Load Lbs.***
3/4	5/16	16 x 2*	250
1	5/16	16 x 2*	250
1¼	5/16	16 x 2*	250
1½	5/16	16 x 2*	250
2	5/16	16 x 2*	250
2½	3/8	3/8 x 2½**	320
3	3/8	3/8 x 2½**	320
3½	3/8	3/8 x 2½**	560
4	3/8	1/2 x 3**	560
5	1/2	1/2 x 3**	560
6	1/2	1/2 x 3**	760
8	1/2	5/8 X 3**	

* Drive screw

** Lag bolt

*** With minimum safety factor of 5
Fastener schedule per NFPA