

Fig. 4L Longitudinal "In-Line" Sway Brace Attachment



Size Range — 2½" through 8" IPS.

Material — Carbon Steel

Function — For bracing pipe against sway and seismic disturbance.

Approvals — Underwriter's Laboratories Listed in the USA (**UL**) and Canada (**cUL**) 2½" - 8". Approved by Factory Mutual Engineering (**FM**), 2½" - 8" pipe.

Installation Instructions — The Fig. 4L is the "braced pipe" attachment component of a longitudinal sway brace assembly. It is intended to be combined with the "bracing pipe" and TOLCO structural attachment component to form a complete bracing assembly. NFPA 13 and/or OSHPD guidelines should be followed.

To Install — Place the Fig. 4L over the pipe to be braced and tighten bolts. Then engage "bracing pipe" into jaw opening and tighten set bolt until hex head snaps off. Jaw attachment can pivot for adjustment to proper brace angle.

Finish — Plain

Note — Available in Electro-Galvanized and HDG finish.

Order By — Figure number, pipe size and finish.

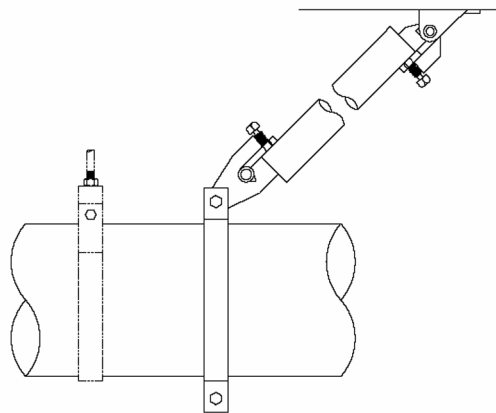
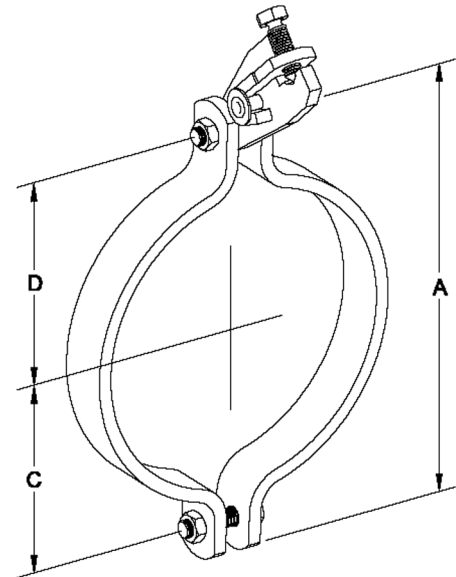

Longitudinal Brace

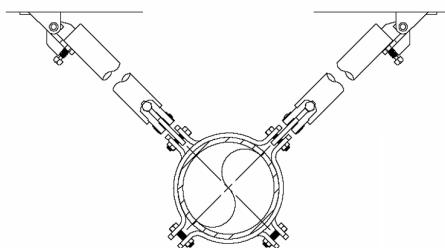

4-Way Riser Brace
(Plan view)

Dimensions • Weights

Sizes	A	C	D	Bolt Size	Max. Rec. Load Lbs. (cULus)	*Max Design Load Lbs. (FM)	Approx. Wt./100
2½	67/16	2½	2¾	1/2	2015	3000	253
3	7	2¾	31/16	1/2	2015	1550	268
4	8½	3¾	31/16	1/2	2015	1550	348
5	9¾	3¾	4¾	1/2	2015	1450	380
6	11½	5	5¾	1/2	2015	1450	640
8	13¼	5¾	5¾	1/2	2015	1450	728

* The loads listed are axial loads on the brace. The horizontal load capacity, H, of the brace is: $H = F \times \sin \theta$, where θ the installation angle measured from the vertical.

FM approved when used with 1", 1¼", 1½" or 2" Sch. 40 brace pipe.

TOLCO® brand bracing components are designed to be compatible **ONLY** with other TOLCO® brand bracing components, resulting in a Listed seismic bracing assembly. **DISCLAIMER** — NIBCO does **NOT** warrant against the failure of TOLCO® brand bracing components, in the instance that such TOLCO® brand bracing components are used in combination with products, parts or systems which are not manufactured or sold under the TOLCO® brand. NIBCO shall **NOT** be liable under any circumstance for any direct or indirect, incidental or consequential damages of any kind, including but not limited to loss of business or profit, where non-TOLCO brand bracing components have been, or are used.