

## Fig. 906 - Sway Brace Multi-Fastener Adapter

Component of State of California OSHPD Approved Seismic Restraints System



**Size Range** — Use with 1" and 1¼" TOLCO UL listed Fig. 900 Series Earthquake Brace Attachments.

**Material** — Carbon Steel

**Application** — Allows sway brace fittings to develop greater load carrying ability by providing multiple fastener attachments. The National Fire Protection (NFPA) provides information on fastener loads to various structures. Refer to NFPA 13 (2010) 9.3.5.9.1.

**Approvals** — Underwriters Laboratories Listed in the USA (UL) and Canada (cUL) only when used with TOLCO 900 Series Earthquake Brace Attachments. Included in our Seismic Restraints Catalog approved by the State of California Office of Statewide Health Planning and Development (OSHPD). For additional load, spacing and placement information relating to OSHPD projects, please refer to the TOLCO Seismic Restraint Systems Guidelines.

**Installation Instructions** — The Fig. 906 is a multiple fastener structural attachment component of a longitudinal or lateral sway brace assembly. It is intended to be combined with a TOLCO transitional attachment, "bracing pipe" and a TOLCO "braced pipe" attachment to form a complete bracing assembly. NFPA 13 and/or OSHPD guidelines should be followed.

**To Install** — Attach the Fig. 906 to the structural surface as per fastener design guidelines. Attach other TOLCO transitional attachment fitting Fig. 909, 910, 980 or 986. Transitional fitting attachment can pivot for adjustment to proper brace angle.

**Finish** — Plain

**Note** — Available in Electro-Galvanized and HDG finish or Stainless Steel materials.

**Order By** — Figure number and specify dimensions H1 and H2.

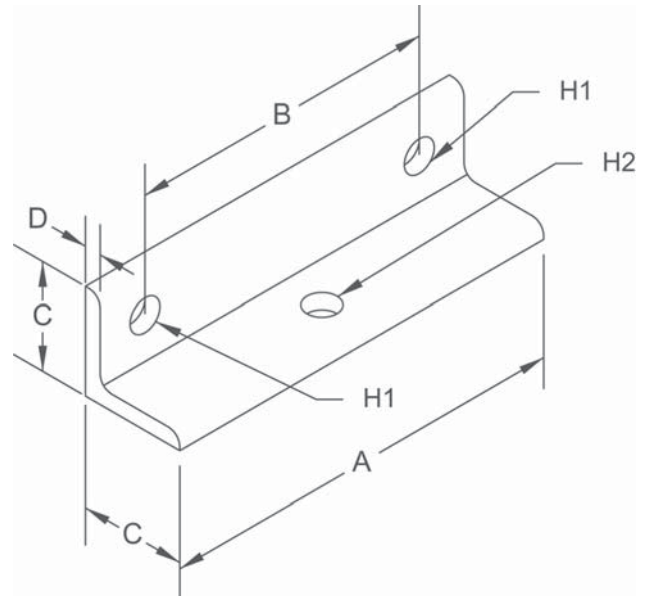

### Dimensions • Weights

A	B	C	D	H1	H2	Approx. Wt./100
12	9	2	1/4	Specify	Specify	Varies

TOLCO® brand bracing components are designed to be compatible **ONLY** with other TOLCO® brand bracing components, resulting in a Listed seismic bracing assembly. **DISCLAIMER** — NIBCO does **NOT** warrant against the failure of TOLCO® brand bracing components, in the instance that such TOLCO® brand bracing components are used in combination with products, parts or systems which are not manufactured or sold under the TOLCO® brand. NIBCO shall **NOT** be liable under any circumstance for any direct or indirect, incidental or consequential damages of any kind, including but not limited to loss of business or profit, where non-TOLCO brand bracing components have been, or are used.