

For Residential, Commercial, Solar and Industrial Applications

Job Name _____

Contractor _____

Job Location _____

Approval _____

Engineer _____

Contractor's P.O. No. _____

Approval _____

Representative _____

Series 601, 601S

Bronze Silent Check Valves

Sizes: 1/4" – 1" (8-25mm)

Series 601, 601S Bronze Silent Check Valves efficiently perform all of the functions of a swing check or vertical lift check valve and at the same time operate silently to prevent the effects of water hammer.

Features:

- Viton® disc
- Integral brass seat
- Install in horizontal or vertical position
(consult factory for proper use in vertical installations)
- Low pressure drop equivalent to a swing check
- Silent operation

Models

- 601 1/4" – 1/2" (8 – 15mm) threaded end connections
- 601S 1/2" – 1" (15 – 25mm) solder end connections*

Specifications

A bronze silent check valve shall be installed as indicated on the plans. The valve shall have a Viton® disc, integral brass seat and silent operation. Pressure rating no less than 400psi (27.6 bars) WOG non-shock. Valve shall be a Watts Regulator Company Series 601 (threaded) or 601S (solder)

Application Notes

These valves are not suggested for installation in sewage ejector piping.

WARNING: Do not use for reciprocating air compressor service.

*This valve is designed to be soft soldered into lines without disassembly using a low temperature solder; 420°F (216°C). Other solders such as 95/5 tin antimony 460°F (238°C) or 96/4 tin silver 430°F (221°C) can be used. However, extreme caution must be used to prevent seat damage. Higher temperature solders will damage the seat material. ANSI B16.18 states that the maximum operating pressure of 50-50 solder connections is 200 psi (13.8 bars) at 100°F (38°C), and decreases with higher temperatures. Apply heat with the flame directed AWAY from the center of the valve body. Excessive heat can harm the seats.



601



601S*

Materials

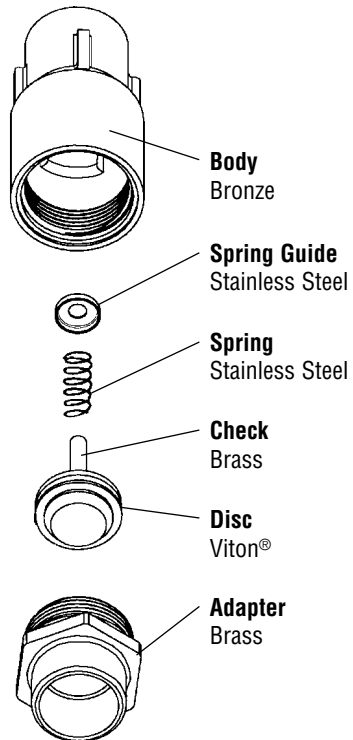

Dimensions – Weights

Series 601

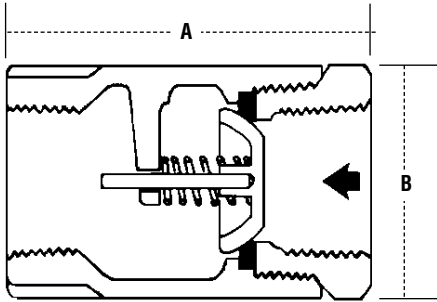

SIZE (DN)		DIMENSIONS				WEIGHT	
		A		B			
<i>in.</i>	<i>mm</i>	<i>in.</i>	<i>mm</i>	<i>in.</i>	<i>mm</i>	<i>lbs.</i>	<i>kg.</i>
Series 601							
1/4	8	2 1/8	54	1 1/4	32	.25	.1
3/8	10	2 1/8	54	1 1/4	32	.5	.2
1/2	15	2 1/8	54	1 1/4	32	.5	.2
Series 601S							
1/2	15	2 1/4	57	1	25	.25	.1
3/4	20	3 3/8	86	1 1/2	38	.63	.3
1	25	3 13/16	97	1 7/8	48	1.0	.5

Series 601S

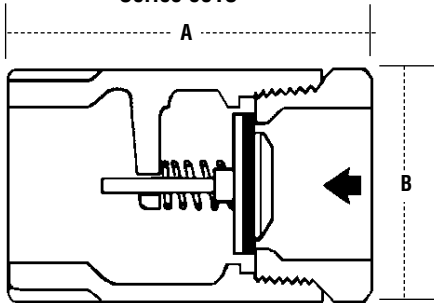

Pressure – Temperature

Maximum Working Pressure:

400psi (27.6 bars) WOG non-shock @ 100° F (38° C)

TEMPERATURE		PRESSURE	
<i>Fahrenheit</i>	<i>Celsius</i>	<i>psi</i>	<i>bars</i>
-20° to 100°	-29° to 38°	400	27.6
200°	93°	200	13.8
250°	121°	160	11.0

Pressure Drop vs. Flow

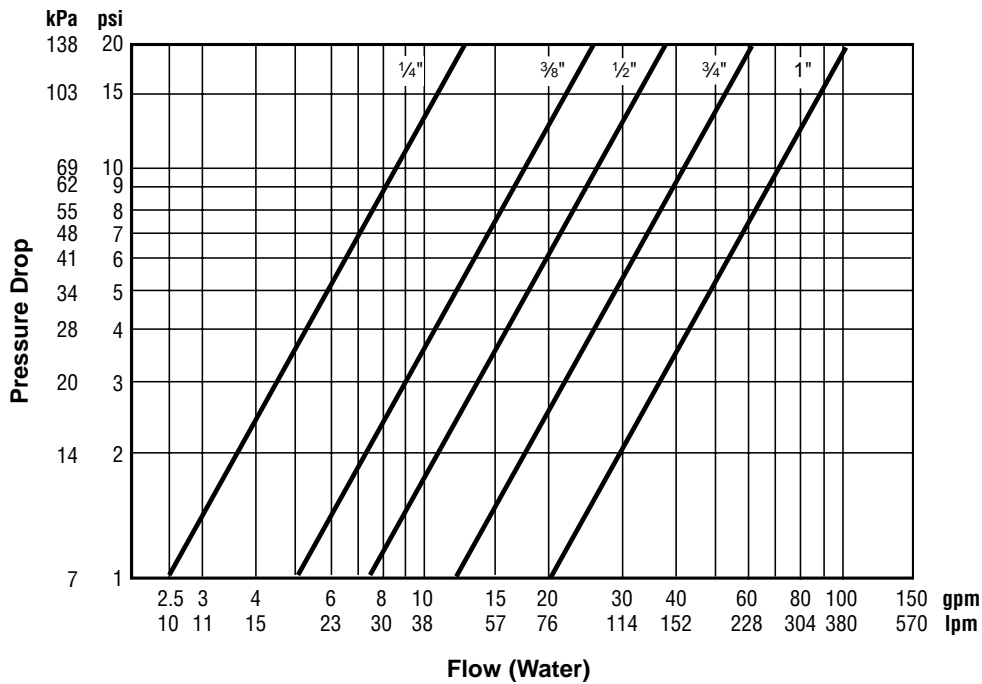

USA: 815 Chestnut St., No. Andover, MA 01845-6098; www.wattsreg.com
 Canada: 5435 North Service Rd., Burlington, ONT L7L 5H7; www.wattscanada.ca