



T TOLCO®

Pipe Hangers
Supports
Seismic Bracing

UL Listed
FM Approved
for Fire Sprinkler
Installations



Catalog Forward

This catalog has been created with an acute awareness of the field problems of the piping contractor. We have sought and received input from engineers, installers, field inspectors and others closely involved with the installation of piping systems. This is where needs are discovered, and where products and services are genuinely tested.

TOLCO® is proud to present a complete and versatile line of pipe hangers and related products. The TOLCO line has been methodically developed to effectively address support problems in the commercial and industrial piping fields.

A thorough knowledge of our customers' needs and problems was no less important than the development of our manufacturing skills in the emergency of TOLCO as a leader in the pipe hanger industry. Our people are equipped to respond quickly to your product and service needs on both standard items and specialized metal fabrication.

Custom Fabrication

We have expanded our manufacturing capacity in response to the growing demand for customized metal fabrication and special hangers. When some detail of construction or piping arrangement makes it necessary to deviate from standard types of hangers, TOLCO is equipped to furnish hangers and supports of any required type. These products combine proven designs and standards with new innovations that enhance their utility.

Approvals and Specifications

TOLCO, as a member of the American Pipe Fittings Association, is cooperating with engineers and architects in the preparation of specifications covering hanger requirements and the interpretation of applicable piping safety codes.

All TOLCO products are carefully manufactured to meet the highest standards in the industry. All products, as a minimum conform to Manufacturers Standardization Society MSS-SP-58, and to the allowable stresses specified in the ANSI B31.1 code for pressure piping.

Many TOLCO Products are also listed, approved or conform to:

Underwriter's Laboratories UL-203
Factory Mutual Engineering
National Fire Protection Association NFPA-13,
NFPA-13R, NFPA-13D and NFPA-24
Federal Specification WW-H-171EE

Warning

Pipe hanger products included in this catalog are intended for installation and service only as described herein.

We are aware that these products have been used (often without incident) for purposes and in ways other than those for which they were designed and manufactured. Examples of which are: use of products as erection tools; use of beam clamps on a beam not specified for them; use of concrete inserts as an anchor for pulling pipe to proper elevation; suspension of one clevis hanger under another resulting in cumulative load greater than specified capability. In such cases of misapplication or improper use, we cannot be held responsible for injuries or property damage.

TOLCO pipe hanger products are carefully designed and manufactured to industry standards. Care should be exercised by installers and end users to install, use and maintain these products properly to avoid any possible on-the-job accidents.

Designs

Product design and specifications are subject to change without notice.

Finishes

Most hangers are available in: stainless steel, electro-galvanized or hot-dipped galvanized. Other special finishes are available upon request. Items ordered hot-dip galvanized may be supplied with electro-galvanized threaded components unless otherwise specified. If you require a finish not listed in the product data of a specific hanger, please consult our factory.

Index

Figure numbers in this catalog are in numerical order.

Terms and Conditions of Sale

For conditions and terms of sale, please consult our current price guide.

Index — Pipe Hangers and Straps



Fig. 1
Standard Clevis Hanger
MSS-SP-69, Type 1
WW-H-171E, Type 1
Page 5

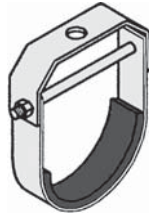


Fig. 1F
Standard Clevis Hanger
with Felt Lining
Page 7



Fig. 1PVC
PVC Coated
Clevis Hanger
MSS-SP-69, Type 1
WW-H-171E, Type 1
Page 7



Fig. 2F
Adjustable Band Hanger
with Felt Lining
MSS-SP-69, Type 10
WW-H-171E, Type 10
Page 9



Fig. 2FWON
Adjustable Band
Hanger
w/o Swivel Nut
with Felt Lining
MSS-SP-69, Type 10
WW-H-171E, Type 10
Page 10



Fig. 2WON
Adjustable Band Hanger
w/o Swivel Nut
MSS-SP-69, Type 7
WW-H-171E, Type 7
Page 10

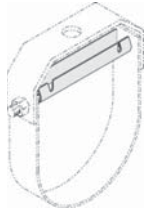


Fig. 1CBS
Cross Bolt Spacer
Page 6



Fig. 2
Adjustable Band Hanger
MSS-SP-69, Type 10
WW-H-171E, Type 10
Page 8

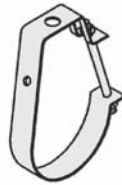


Fig. 3
J-Hanger for
Pipe or Conduit
MSS-SP-69, Type 5
Page 11



Fig. 3F
J-Hanger with Felt Lining
MSS-SP-69, Type 5
Page 11



Fig. 3PVC
J-Hanger
with PVC Coating
MSS-SP-69, Type 5
Page 11

Fig. 200WON
Trimline Band Hanger
w/o Swivel Nut
MSS-SP-69, Type 7
WW-H-171E, Type 7
Page 43

Fig. 200
Trimline Band Hanger
MSS-SP-69, Type 10
WW-H-171E, Type 10
Page 41

Fig. 200F
Heavy Duty Band
Hanger (for Trapeze)
MSS-SP-69, Type 10
WW-H-171E, Type 10
Page 42

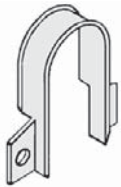


Fig. 24
Hanger for
CPVC Plastic Pipe,
Double Fastener Strap
Type Side Mount
Page 19

Fig. 2NFPA
Trimline Band Hanger
with Reducer Rod Size
MSS-SP-69, Type 10
WW-H-171E, Type 10
Page 8

Fig. 200
Trimline Band Hanger
MSS-SP-69, Type 10
WW-H-171E, Type 10
Page 40



Fig. 22
Hanger for CPVC
Plastic Pipe
Single Fastener Type
Page 17

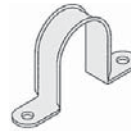


Fig. 23
Hanger for CPVC
Plastic Pipe, Double
Fastener Strap Type
Page 18



Fig. 120
U-Hanger
Page 37



Fig. 120RWA (B)
Retrofit Wrap Around
U-Hanger Clamp
MSS-SP-69, Type 4
WW-H-171E, Type 4
Page 38



Fig. 28
Standoff Hanger and
Restrainer for CPVC
Plastic Pipe
Page 22

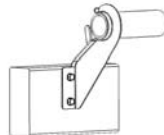


Fig. 29
CPVC Double Offset
Page 23

NOTE: For more information on TOLCO products, please see TOLCO® Pipe Hangers and Support Systems Catalog.

Index — Pipe Clamps



Fig. 4
Standard Pipe Clamp
MSS-SP-69, Type 4
WW-H-171E, Type 4
Page 12

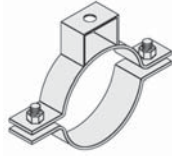


Fig. 4B
Seismic
Pipe Clamp
Page 14



Fig. 4F
Standard Pipe Clamp
with Felt Lining
MSS-SP-69, Type 4
WW-H-171E, Type 4
Page 12



Fig. 4PVC
PVC Coated
Pipe Clamp
Page 12



Fig. 6
Riser Clamp
MSS-SP-69, Type 8
WW-H-171E, Type 8
Page 16

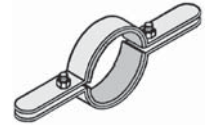


Fig. 6F
Riser Clamp
with Felt Lining
MSS-SP-69, Type 8
Ww-H-171E, Type 8
Page 16

Fig. 4A
Pipe Clamp for
Sway Bracing
Page 13



Fig. 6PVC
PVC Coated
Riser Clamp
MSS-SP-69, Type 8
WW-H-171E, Type 8
Page 16

Beam Clamps and Accessories



Fig. 61T
Threaded Top Hook
Page 27



Fig. 65
Steel Reversible
"C" Type Beam Clamp
with Lock Nut
3/4" Opening
MSS-SP-69,
Type 19 & 23
WW-H-171E, Type 23
Page 28



Fig. 66
Steel Reversible
"C" Type Beam Clamp
with Lock Nut
1 1/4" Opening
MSS-SP-69,
Type 19 & 23
WW-H-171E, Type 23
Page 28

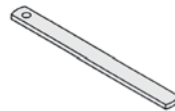


Fig. 69
Beam Clamp
Retaining Strap
Page 31



Fig. 69R
Retrofit Capable
Beam Clamp
Retaining Strap
Page 31

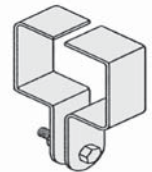


Fig. 130
Beam Clamp with
Bolt and Nut
Page 39

Upper Attachments



Fig. 42
Angle Bracket
Page 24

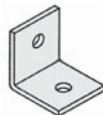


Fig. 50
Side Beam Bracket
Page 24



Fig. 51
Side Beam Bracket
for NFPA Pipe Sizing
Page 25

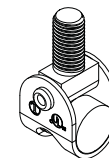


Fig. 58
Threaded Side
Beam Bracket
Page 26

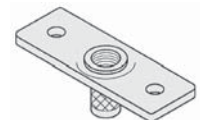


Fig. 75
Swivel
Page 32

Fig. 78
All Steel
Ceiling Plate
Page 33

NOTE: For more information on TOLCO products, please see TOLCO® Pipe Hangers and Support Systems Catalog.

Index — Concrete Inserts

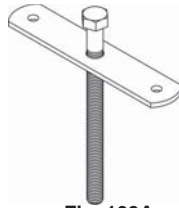


Fig. 109A
Concrete Deck Insert
Page 35

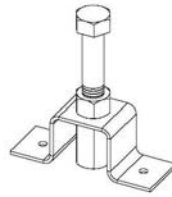


Fig. 109AF
Concrete Insert
Page 36



Fig. 150
"Wing-It" Concrete Deck Insert
Page 41

Threaded Products & Accessories

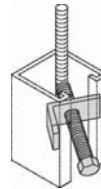


Fig. 98
Rod Stiffener
Page 34

Seismic Brace Attachments



Fig. 4L
Longitudinal "In-Line"
Sway Brace Attachment
Page 15



Fig. 25
Surge Restrainer
Page 20

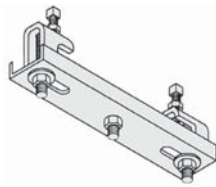


Fig. 800
Adjustable Sway Brace
Attachment to Steel
Page 44

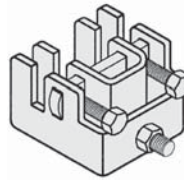


Fig. 825
Bar Joist Sway
Brace Attachment
Page 45

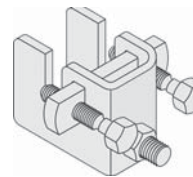


Fig. 825A
Bar Joist Sway
Brace Attachment
Page 46

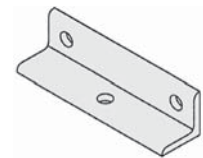


Fig. 906
Sway Brace
Multi-Fastener Adapter
Page 47

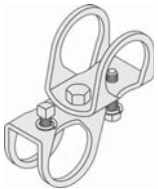


Fig. 907
4-Way Longitudinal
Sway Brace Attachment
Page 48

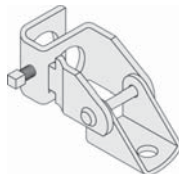


Fig. 909
No-Thread Swivel
Sway Brace Attachment
Page 49

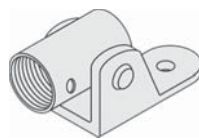


Fig. 910
Swivel
Sway Brace Fitting
Page 50



Fig. 975
Straight
Sway Brace Fitting
Page 51

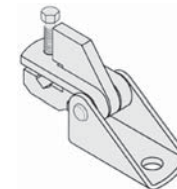


Fig. 980
Universal Swivel
Sway Brace Attachment
Page 52



Fig. 981
Retrofit Universal Sway
Brace Attachment
Page 53



Fig. 990
Cable Sway Brace
Attachment
Page 54

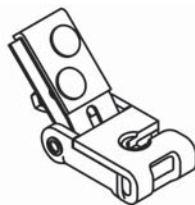


Fig. 991
Cable Sway Brace
Attachment
Page 55



Fig. 1000
"Fast Clamp"
Sway Brace Attachment
Page 56



Fig. 1001
Sway Brace Attachment
Page 57



Fig. 2002
Sway Brace Attachment
Page 58

NOTE: For more information on TOLCO products, please see TOLCO® Pipe Hangers and Support Systems Catalog.

Fig. 1 - Standard Clevis Hanger

Size Range — Size 1/2" thru 36" pipe.

Material — Carbon Steel

Function — Recommended for the suspension of non-insulated pipe or insulated pipe with Fig. 220 shield.

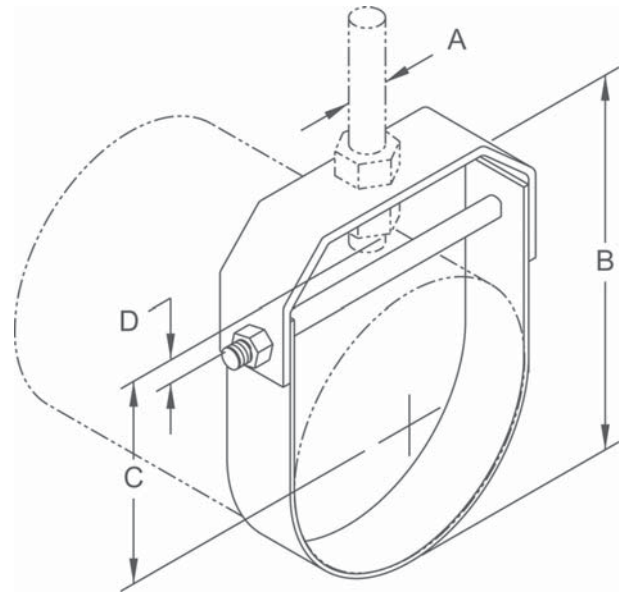
Note — When an oversized clevis is used, a pipe spacer should be placed over the cross bolt to assure that the lower U-strap will not move in on the bolt. When attaching seismic bracing to clevis hangers, a Fig. 1 CBS (cross bolt spacer) must be installed. See TOLCO® Seismic Restraint Approval Guidelines.

Approvals — Underwriters' Laboratories Listed in the USA (UL), Canada (cUL) 3/4" thru 8". Conforms to Federal Specification WW-H-171E, Type 1, and Manufacturers Standardization Society SP-69, Type 1. Also available to accommodate rod schedule per National Fire Protection Association (NFPA) Pamphlet 13. Included in our Seismic Restraints Catalog approved by the State of California Office of Statewide Health Planning and Development (OSHPD). For additional load, spacing and placement information relating to OSHPD projects, please refer to the TOLCO Seismic Restraint Systems Guidelines.

Maximum Temperature — 650°F

Finish — Plain

Note — Available in Electro-Galvanized and HDG finish or Stainless Steel.



Dimensions • Weights

Pipe Size	Rod Size A		B	C	D	Max. Rec. Load Lbs.	Approx. Wt./100
	STD	NFPA					
1/2	3/8	3/8	2 ¹ / ₁₆	1 ³ / ₁₆	1	610	36
3/4	3/8	3/8	2 ⁷ / ₈	1 ⁷ / ₈	1	610	38
1	3/8	3/8	3 ¹ / ₄	2 ¹ / ₁₆	1	610	42
1 ¹ / ₄	3/8	3/8	3 ⁹ / ₁₆	2 ¹ / ₄	1	610	46
1 ¹ / ₂	3/8	3/8	3 ⁷ / ₈	2 ³ / ₈	1	610	49
2	3/8	3/8	4 ⁷ / ₁₆	2 ³ / ₄	1	610	55
2 ¹ / ₂	1/2	3/8	5 ⁵ / ₁₆	3 ¹ / ₄	1	1130	124
3	1/2	3/8	5 ¹⁵ / ₁₆	3 ¹ / ₂	1 ¹ / ₄	1130	140
3 ¹ / ₂	1/2	3/8	6 ⁷ / ₁₆	3 ³ / ₄	1 ¹ / ₄	1130	152
4	5/8	3/8	7 ³ / ₈	4 ¹ / ₄	1 ¹ / ₂	1430	190
5	5/8	1/2	8 ¹⁵ / ₁₆	5 ¹ / ₄	1 ¹ / ₂	1430	235
6	3/4	1/2	9 ¹³ / ₁₆	5 ¹ / ₂	1 ¹ / ₂	1940	317
8	3/4	1/2	12 ⁹ / ₁₆	7 ¹ / ₈	2	2000	428
10	7/8	5/8	16 ¹ / ₄	9 ⁵ / ₈	3 ¹ / ₄	3600	918
12	7/8	5/8	18 ⁹ / ₁₆	10 ¹³ / ₁₆	3 ¹ / ₈	3800	1086
14	1	—	20 ³ / ₄	12 ³ / ₈	4	4200	1267
16	1	—	22 ⁷ / ₈	13 ³ / ₁₆	3 ³ / ₄	4600	1930
18	1	—	25 ³ / ₄	15 ⁹ / ₃₂	4 ⁷ / ₁₆	4800	2264
20	1 ¹ / ₄	—	28 ¹³ / ₁₆	17 ¹ / ₁₆	5 ³ / ₁₆	4800	3531
*24	1 ¹ / ₄	—	32 ¹ / ₈	18 ¹ / ₄	4 ⁷ / ₁₆	4800	4431
*30	1 ¹ / ₄	—	38 ⁷ / ₈	21 ⁷ / ₈	5	6000	6940
*36	1 ¹ / ₂	—	48	27 ³ / ₄	5 ³ / ₄	9500	18103

*Furnished with pipe spacer to support maximum load rating

Fig. 1CBS - Clevis Bolt Spacer

Component of State of
California OSHPD Approved
Seismic Restraints System

Size Range — Size 1" thru 20" clevis hanger

Material — Carbon Steel

Function — Used as a spacer at a seismic brace location to keep clevis hanger from collapsing during seismic event.

Approvals — Included in our Seismic Restraints Catalog approved by the State of California Office of Statewide Health Planning and Development (OSHPD). For additional load, spacing and placement information relating to OSHPD projects, please refer to the TOLCO Seismic Restraint Systems Guidelines.

Installation Note — Fig. 1CBS fits easily over the cross bolt and attaches by pinching tabs down.

Finish — Mil Galvanized

Note — Available in HDG finish or Stainless Steel materials.

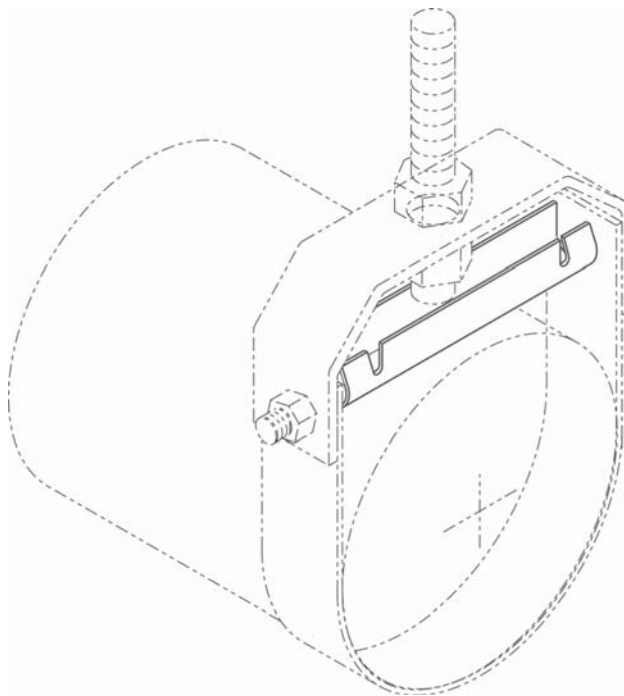
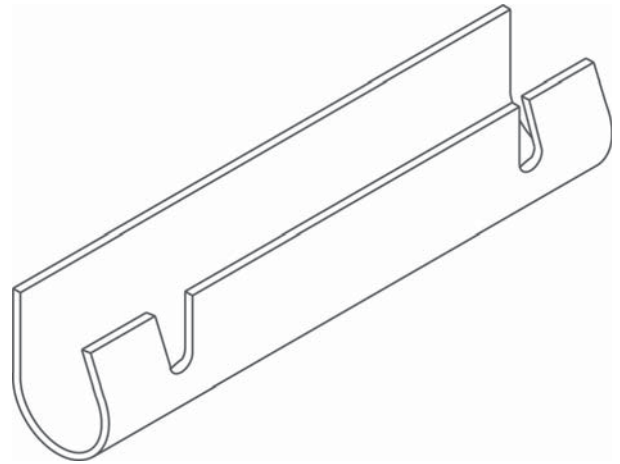


Fig. 1F — Felt Lined Standard Clevis Hanger

Fig. 1PVC — PVC Coated Standard Clevis Hanger



Size Range — Size 1/2" thru 8" pipe.

Material — Carbon Steel

Insulation Material — 3/16" felt

Function — The Fig. 1F is designed for the suspension of copper tube so as to prevent electrolysis between tube and hanger. The Fig. 1PVC is designed for steel or other pipe types of same O.D. Both Fig. 1F and Fig. 1PVC act to reduce noise and vibration in pipe or tube system.

Approvals — Underwriters' Laboratories Listed in the USA (UL) and Canada (cUL).

Maximum Temperature — 650°F

Finish — Plain

Note —When Fig. 1F is used for steel or other pipe types, consult factory for proper size hanger. Available in Electro-Galvanized and HDG finish or Stainless Steel.

Order By — Figure number, nominal tube size and finish

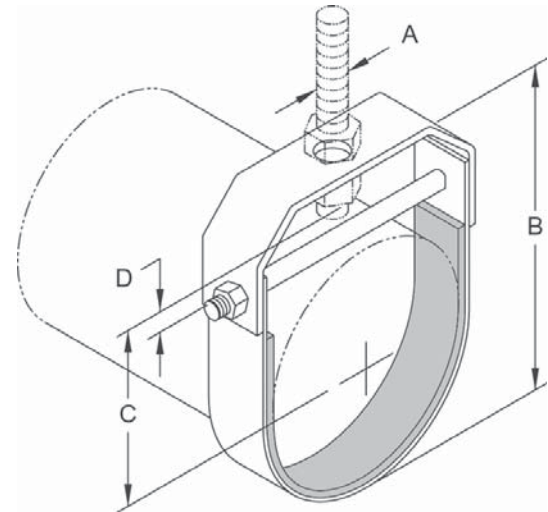


Fig. 1F

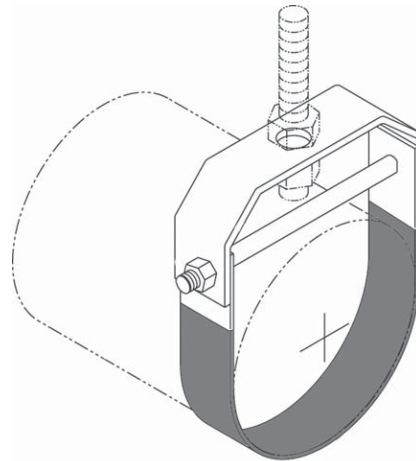


Fig. 1PVC

Dimensions • Weights

Pipe Size	Rod Size A		B	C	D	Max. Rec. Load Lbs.	Approx. Wt./100
	STD	NFPA					
1/2	3/8	3/8	27/8	1	1	610	36
3/4	3/8	3/8	31/16	111/16	1	610	38
1	3/8	3/8	33/8	17/8	1	610	43
1 1/4	3/8	3/8	33/4	21/16	1	610	47
1 1/2	3/8	3/8	41/16	23/16	1	610	50
2	3/8	3/8	4 1/2	29/16	1	610	56
2 1/2	1/2	3/8	5 1/2	31/16	1	1130	125
3	1/2	3/8	6 1/8	35/16	1 1/4	1130	141
3 1/2	1/2	3/8	6 3/4	39/16	1 1/4	1130	153
4	5/8	3/8	7 5/8	41/16	1 1/2	1430	191
5	5/8	1/2	8 7/8	51/16	1 1/2	1430	236
6	3/4	1/2	10	55/16	1 1/2	1940	318
8	3/4	1/2	12 3/4	615/16	2	2000	429

Fig. 2 — Adjustable Band Hanger

Fig. 2NFPA — Adjustable Band Hanger with Reduced Rod



Size Range — Size 2½" thru 6" pipe.

Material — Carbon Steel, Pre-Galvanized

Function — Recommended for the suspension of non-insulated pipe or insulated pipe with Fig. 220 shield.

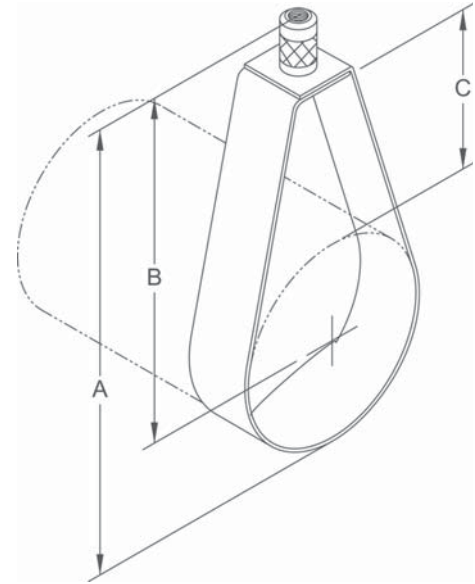
Fig. 2NFPA accommodates the reduced rod schedule of the National Fire Protection Association Pamphlet 13.

Approvals — Factory Mutual Engineering approved. Underwriters Laboratories Listed. Conforms to Federal Specification WW-H-171E, Type 10 and Manufacturers Standardization Society SP-69, Type 10.

Finish — Pre-Galvanized

Note — Available in Stainless Steel materials.

Order By — Figure number, pipe size and material



Dimensions • Weights

Pipe Size	Rod Size	A	B	C	Max. Rec. Load Lbs.	Approx Wt./100	
						Fig. 2	Fig. 2NFPA
2½	1/2*	5¾	4¼	1⅝	600	41	40
3	1/2*	6	4⅞	1¼	600	45	43
3½	1/2*	7⅜	5¼	2⅛	600	52	50
4	5/8*	7⅜	5	1⅝	1000	59	56
5	5/8**	9	6⅞	2¼	1250	97	95
6	3/4**	9⅜	6½	1⅞	1250	139	105

* 3/8" nut is used when NFPA rod sizing is requested.

** 1/2" nut is used when NFPA rod sizing is requested.

Fig. 2F - Adjustable Band Hanger with Felt Lining



Size Range — 1/2" thru 6" copper tubing

Material — Carbon Steel, Pre-Galvanized

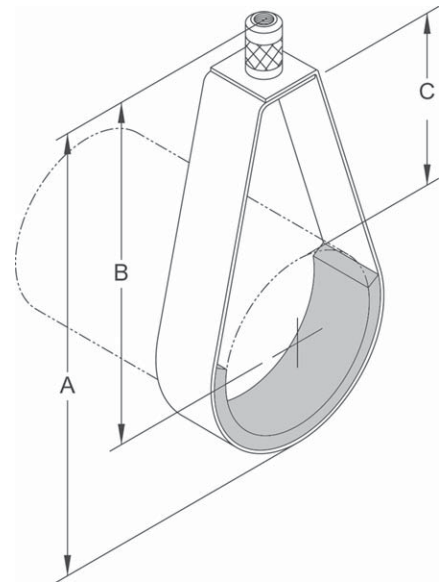
Function — Recommended for the suspension of copper tube so as to prevent electrolysis. The felt lining also acts to reduce noise in copper or other pipe types.

Approvals — Underwriters' Laboratories Listed in the USA (**UL**) and Canada (**cUL**). Conforms to Federal Specification WW-H-171E, Type 10 and Manufacturers Standardization Society SP-69, Type 10.

Finish — Pre-Galvanized

Note — When used for steel or other pipe types, consult factory for proper size. Available in Stainless Steel materials.

Order By — Figure number and copper tube size



Dimensions • Weights

Copper Tube Size	Rod Size	A	B	C	Max. Rec. Load Lbs.	Approx. Wt./100
1/2	3/8	3 1/8	2 5/8	1 3/8	400	12
3/4	3/8	3 1/8	2 1/2	1 1/8	400	12
1	3/8	3 3/8	2 5/8	1 1/8	400	13
1 1/4	3/8	3 3/4	2 7/8	1 1/4	400	14
1 1/2	3/8	3 7/8	2 7/8	1 1/8	400	15
2	3/8	4 1/4	3	1	400	16
2 1/2*	1/2	5 3/4	4 1/8	1 3/4	600	41
3*	1/2	6	4	1 1/2	600	46
3 1/2*	1/2	7 3/8	5 1/4	1 3/8	600	53
4*	5/8	7 3/8	5	1 7/8	1000	60
5**	5/8	9	6 1/8	2 1/2	1250	98
6**	3/4	9 3/8	6 1/2	2 1/4	1250	140

* 3/8" nut is used when requested.

** 1/2" nut is used when requested.

Fig. 2WON - Adjustable Band Hanger w/o Swivel Nut

Fig. 2FWON - Felt Lined Band Hanger w/o Swivel Nut

Size Range — (Fig. 2WON) Size 2" thru 8" pipe.

(Fig. 2F WON) 1/2" thru 8" copper tube

Material — Pre-Galvanized Steel

Function — Recommended for the suspension of non-insulated pipe or insulated pipe with Fig. 220 shield.

Approvals — Underwriters' Laboratories Listed in the USA (**UL**) and Canada (**cUL**). Conforms to Federal Specification WW-H-171E, Type 7, and Manufacturers Standardization Society SP-69, Type 7, 3/4" thru 6". Figure 2WON is included in our Seismic Restraints catalog approved by the state of California.

Finish — Pre-Galvanized

Note — Available in Stainless Steel materials.

Order By — Figure number and pipe size

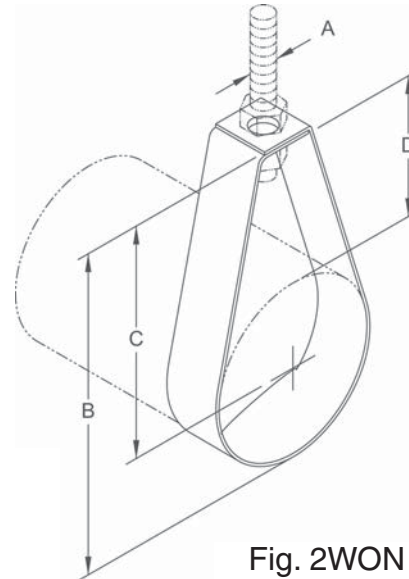


Fig. 2WON

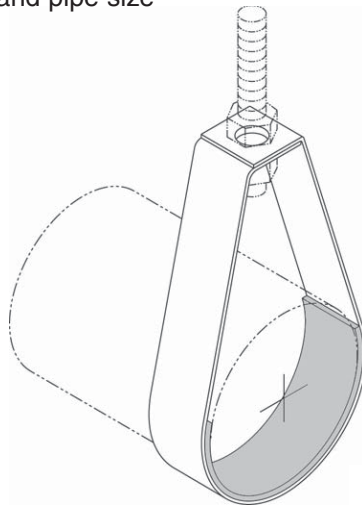


Fig. 2F WON

Dimensions • Weights

Pipe Size	Rod Size A	B	C	D	Max. Rec. Load Lbs.	Approx. Wt./100
1/2	3/8	2 ⁵ / ₈	2 ¹ / ₈	1 ¹ / ₄	400	14
3/4	3/8	2 ⁵ / ₈	2	1	400	14
1	3/8	2 ⁷ / ₈	2 ¹ / ₈	1	400	16
1 ¹ / ₄	3/8	3 ³ / ₈	2 ¹ / ₂	1 ¹ / ₄	400	17
1 ¹ / ₂	3/8	3 ¹ / ₂	2 ¹ / ₂	1	400	18
2	3/8	3 ³ / ₄	2 ¹ / ₂	7/8	400	20
2 ¹ / ₂	1/2*	5	3 ¹ / ₂	1 ¹ / ₂	600	27
3	1/2*	5 ¹ / ₂	3 ⁵ / ₈	1 ¹ / ₄	600	40
3 ¹ / ₂	1/2*	6 ³ / ₄	4 ⁵ / ₈	2	600	48
4	5/8*	6 ³ / ₄	4 ³ / ₈	1 ¹ / ₂	1000	53
5	5/8**	8 ¹ / ₂	5 ⁵ / ₈	2 ¹ / ₈	1250	91
6	3/4**	9 ¹ / ₄	5 ⁷ / ₈	1 ⁵ / ₈	1250	99
8	3/4**	12 ¹ / ₄	7 ⁷ / ₈	2 ⁵ / ₈	1250	120

* 3/8" nut is used when NFPA rod sizing is requested.

** 1/2" nut is used when NFPA rod sizing is requested.

Fig. 3 - J-Hanger for Pipe or Conduit
Fig. 3F - Felt Lined J-Hanger for Copper Tubing
Fig. 3PVC - PVC Coated J-Hanger for Pipe or Conduit

 Component of State of
 California OSHPD Approved
 Seismic Restraints System

Size Range — 1/2" thru 12" pipe size

Material — Carbon Steel

Function — Recommended for the suspension of non-insulated pipe, or insulated pipe with Fig. 220 shield. Side hole allows for wall mounting. Fig. 3F and Fig. 3PVC are designed to reduce noise and vibration and/or prevent electrolysis between pipe and hanger.

Approvals — Conforms to Manufacturers Standardization Society SP-69, Type 5. Included in our Seismic Restraints Catalog approved by the State of California Office of Statewide Health Planning and Development (OSHPD). For additional load, spacing and placement information relating to OSHPD projects, please refer to the TOLCO Seismic Restraint Systems Guidelines.

Finish — Electro-Galvanized

Note — Available in HDG finish or Stainless Steel materials.

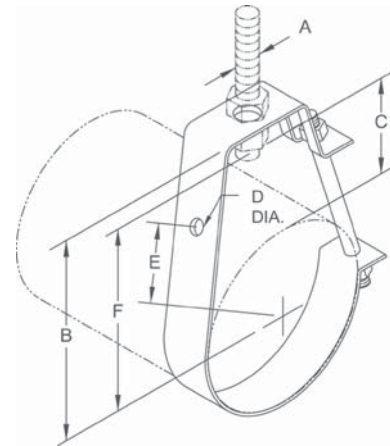
Order By — Figure number, pipe size and finish


Fig. 3

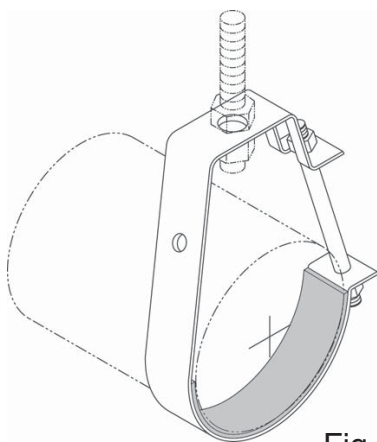


Fig. 3F

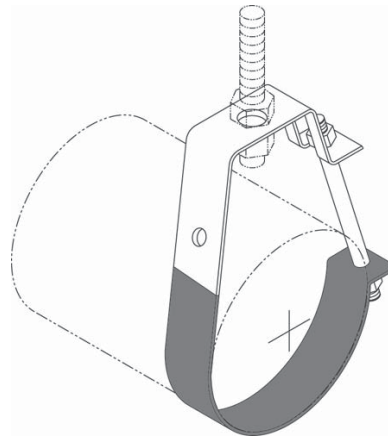


Fig. 3PVC

Dimensions • Weights

Copper Tube Size	Rod Size A	B	C	D	E	F	Max. Rec. Load Lbs.	Approx. Wt./100
1/2	3/8	2 ⁵ / ₈	1 ³ / ₄	7/16	1 ¹ / ₂	1 ¹⁵ / ₁₆	400	18
3/4	3/8	2 ⁷ / ₈	1 ⁷ / ₈	7/16	1 ¹¹ / ₁₆	2 ¹ / ₈	400	21
1	3/8	2 ¹⁵ / ₁₆	1 ¹⁵ / ₁₆	7/16	1 ¹³ / ₁₆	2 ⁵ / ₁₆	400	22
1 ¹ / ₄	3/8	3 ¹ / ₄	2	7/16	2 ¹ / ₁₆	2 ⁵ / ₈	400	25
1 ¹ / ₂	3/8	3 ⁹ / ₁₆	2 ³ / ₁₆	7/16	2 ⁷ / ₁₆	2 ⁷ / ₈	400	27
2	3/8	3 ¹¹ / ₁₆	2 ¹ / ₈	7/16	2 ⁹ / ₁₆	3 ¹ / ₁₆	400	29
2 ¹ / ₂	1/2	4 ⁷ / ₁₆	2 ⁷ / ₁₆	9/16	3 ³ / ₁₆	3 ⁵ / ₈	500	64
3	1/2	4 ¹³ / ₁₆	2 ⁹ / ₁₆	9/16	3 ¹ / ₂	4 ¹ / ₁₆	500	72
3 ¹ / ₂	1/2	5 ¹ / ₈	2 ⁵ / ₈	9/16	3 ³ / ₄	4 ³ / ₈	500	84
4	5/8	6 ¹ / ₈	3 ³ / ₁₆	9/16	4 ⁵ / ₈	5 ³ / ₁₆	550	138
5	5/8	6 ³ / ₄	3 ¹ / ₄	9/16	5 ¹ / ₁₆	5 ³ / ₄	550	162
6	3/4	7 ³ / ₄	3 ⁹ / ₁₆	9/16	5 ¹³ / ₁₆	6 ⁵ / ₈	600	249
8	7/8	9 ³ / ₁₆	3 ¹⁵ / ₁₆	9/16	6 ¹⁵ / ₁₆	8	760	291
10	7/8	10 ³ / ₄	3 ⁷ / ₈	9/16	7 ⁵ / ₈	9 ¹ / ₈	760	315

Fig. 4 - Standard Pipe Clamp

Fig. 4F - Standard Pipe Clamp Felt Lined

Fig. 4PVC - Standard Pipe Clamp PVC Coated

 Component of State of
 California OSHPD Approved
 Seismic Restraints System

Size Range — (Fig. 4) Size 1/2" thru 30" pipe.

Size Range — (Fig. 4F) Size 1/2" thru 2 1/2" copper tubing

Material — Carbon Steel

Function — Recommended for the suspension of non-insulated pipe or insulated pipe with Fig. 220 shields. (Use Fig. 330 Weldless Eye Nut, Fig. 102 Eye Rod or Fig. 101 Welded Eye Rod.) Also recommended for attachment of sway bracing up to 3 1/2" pipe size, for larger pipe sizes use Fig. 4A. Fig. 4F and Fig. 4PVC are designed to reduce noise and vibration and/or prevent electrolysis.

Approvals — Underwriters' Laboratories Listed in the USA (UL), Canada (cUL) 1/2" - 8", and approved by Factory Mutual Engineering, 3/4" - 8". Federal Specification WW-H-171E, Type 4, 1 1/2" thru 24" and Manufacturers Standardization Society SP-69, Type 4. Included in our Seismic Restraints Catalog approved by the State of California Office of Statewide Health Planning and Development (OSHPD). For additional load, spacing and placement information relating to OSHPD projects, please refer to the TOLCO Seismic Restraint Systems Guidelines.
Note — When the Fig. 4 is used as a sway brace, to ensure performance, the **UL Listing requires that it must be used with other TOLCO® brace products.**
Maximum Temperature — 750°F

Finish — Plain

Note — Available in Electro-Galvanized and HDG finish or Stainless Steel materials.

Order By — Figure number, pipe size and finish.

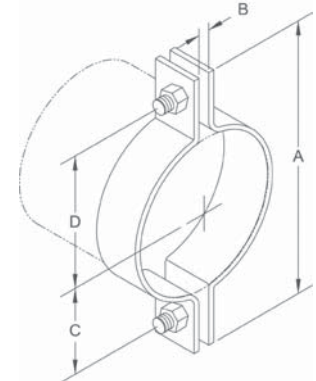
Order Note — When ordering Fig. 4F allow for 3/16" felt on each half of clamp.


Fig. 4

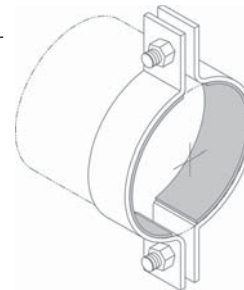


Fig. 4F

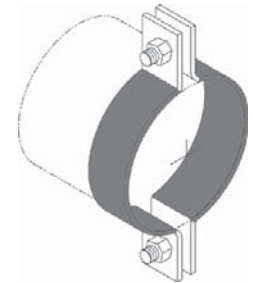


Fig. 4PVC

Dimensions • Weights

Pipe Size	A	B	C	D	Bolt Size	Max. Design Load Lbs.		Approx. Wt./100
						650°	750°F	
1/2	37/16	1/4	1 1/8	1 1/8	5/16	500	445	29
3/4	39/16	1/4	1 1/4	1 1/4	5/16	500	445	31
1	39/16	1/4	1 1/4	1 5/16	5/16	500	445	35
1 1/4	43/16	3/8	1 3/8	1 11/16	5/16	500	445	40
1 1/2	49/16	3/8	1 5/8	1 7/8	5/16	800	715	42
2*	59/16	3/8	2	2 1/4	3/8	1040	930	93
2 1/2*	67/16	3/8	2 1/2	2 3/4	1/2	1040	930	126
3*	7	3/8	2 3/4	3 1/16	1/2	1040	930	141
3 1/2*	7 11/16	3/8	3 1/8	3 3/8	1/2	1040	930	154
4	8 1/2	5/8	3 5/16	3 11/16	1/2	1040	930	229
5	9 3/4	3/4	3 7/8	4 3/8	5/8	1040	930	261
6	11 5/8	3/4	4 7/8	5 1/8	3/4	1615	1440	537
8	13 5/16	1	5 5/8	6	3/4	1615	1440	625
10	16 1/2	1	7 1/4	7 1/4	7/8	2490	2220	1378
12	18 1/2	1	8 1/4	8 1/4	7/8	2490	2220	1574
14	20	1 1/8	9	9	7/8	2490	2220	2103
16	23	1 1/8	10 1/4	10 1/4	7/8	2490	2220	2314
18	25 7/8	1 1/4	11 1/2	11 1/2	1	3060	2730	3276
20	28	1 3/8	12 1/2	12 1/2	1 1/8	3060	2730	3863
24	33 1/2	1 5/8	15 1/4	15 1/4	1 1/4	3060	2730	5222
30	41 7/8	2	19	19	1 3/4	3500	3360	10511

*Meets UL 203A requirements for attachment of sway bracing. Horizontal design load for 1/2"-2" - 380#, 2 1/2" - 395#, 3" - 435#, 3 1/2" - 540#

Fig. 4A - Pipe Clamp for Sway Bracing

Size Range — 4" thru 8" pipe. For sizes smaller than 4" use TOLCO® Fig. 4.

Material — Carbon Steel

Function — For bracing pipe against sway and seismic disturbance.

Approvals — Underwriters' Laboratories Listed in the USA (**UL**) and Canada (**cUL**) 4" thru 8". Included in our Seismic Restraints Catalog approved by the State of California Office of Statewide Health Planning and Development (OSHPD).

Installation Instructions — The Fig. 4A is the "braced pipe" attachment component of a longitudinal, lateral or riser brace assembly. It is intended to be combined with the "bracing pipe" and TOLCO transitional and structural attachment component(s) to form a complete bracing assembly. NFPA 13 and/or OSHPD guidelines should be followed.

To Install — Place the Fig. 4A over the pipe to be braced. Attach TOLCO transitional fitting, either Fig. 980, 910 or 909, to the clamp ears. Tighten bolts and nuts; torque requirement is a minimum of 50 ft. lbs. Transitional fitting attachment can pivot for adjustment to proper brace angle.

Finish — Plain

Note — Available in Electro-Galvanized and HDG finish or Stainless Steel materials.

Order By — Figure number, pipe size and finish

Component of State of California OSHPD Approved Seismic Restraints System

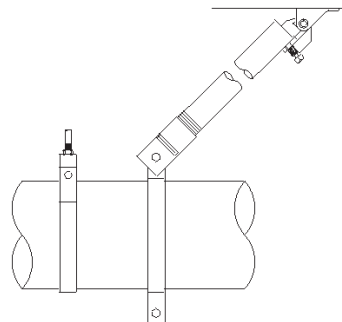
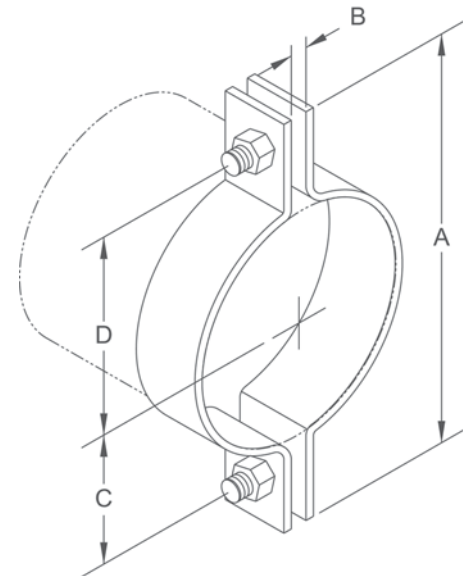


Fig. 4A - Longitudinal Brace

TOLCO® brand bracing components are designed to be compatible **ONLY** with other TOLCO® brand bracing components, resulting in a Listed seismic bracing assembly. **DISCLAIMER** — NIBCO does **NOT** warrant against the failure of TOLCO® brand bracing components, in the instance that such TOLCO® brand bracing components are used in combination with products, parts or systems which are not manufactured or sold under the TOLCO® brand. NIBCO shall **NOT** be liable under any circumstance for any direct or indirect, incidental or consequential damages of any kind, including but not limited to loss of business or profit, where non-TOLCO brand bracing components have been, or are used.

Dimensions • Weights

Pipe Sizes	A	B	C	D	Bolt Size	Max. Horizontal Design Load	Approx. Wt./100
4	8½	9/16	3⅝	3 ¹¹ / ₁₆	1/2	2015	221
5	9¾	9/16	3⅝	4⅜	1/2	2015	253
6	11½	5/8	5	5⅝	1/2	2015	513
8	13¼	3/4	6 ¹ / ₁₆	6⅝	1/2	2015	601

Fig. 4B - Pipe Clamp for Sway Bracing

Size Range — 3/4" thru 8" pipe.

Material — Carbon Steel

Function — For bracing pipe against sway and seismic disturbance.

Features — This product's design incorporates concentric loading of the "brace pipe", connection components and fasteners which is critical to the performance of seismic bracing assemblies.

Approvals — Underwriters Laboratories Listed in the USA (**UL**) and Canada (**cUL**). Included in our Seismic Restraints Catalog approved by the State of California Office of Statewide Health Planning and Development (**OSHPD**).

Finish — Plain

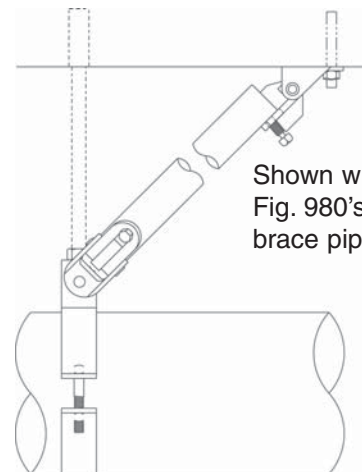
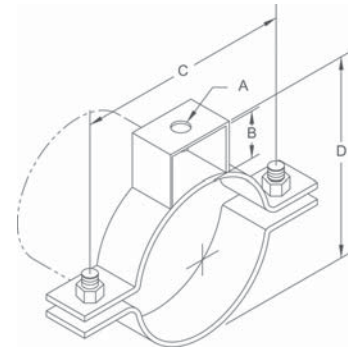
Note — Available in Electro-Galvanized and HDG finish or Stainless Steel materials.

Order By — Figure number, pipe size and finish.

Installation Instructions — The Fig. 4B is the "braced pipe" attachment component of a longitudinal or lateral sway brace assembly. It is intended to be combined with the "bracing pipe" and TOLCO transitional and structural attachment component(s) to form a complete bracing assembly. NFPA 13 and/or OSHPD guidelines should be followed.

To Install — Place the Fig. 4B over the pipe to be braced. Attach other TOLCO transitional fitting, Fig. 909, 910 or 980. Tighten bolts and nuts. Transitional fitting attachment can pivot for adjustment to proper brace angle.

Component of State of California OSHPD Approved Seismic Restraints System



Shown with two TOLCO® Fig. 980's and Schedule 40 brace pipe.

Fig. 4B - Hanger/Longitudinal Brace

TOLCO® brand bracing components are designed to be compatible **ONLY** with other TOLCO® brand bracing components, resulting in a Listed seismic bracing assembly. **DISCLAIMER** — NIBCO does **NOT** warrant against the failure of TOLCO® brand bracing components, in the instance that such TOLCO® brand bracing components are used in combination with products, parts or systems which are not manufactured or sold under the TOLCO® brand. NIBCO shall **NOT** be liable under any circumstance for any direct or indirect, incidental or consequential damages of any kind, including but not limited to loss of business or profit, where non-TOLCO brand bracing components have been, or are used.

Dimensions • Weights

Pipe Sizes	Rod Size A	B	C	D	Bolt Size	Max. Design Load Lbs.	Approx. Wt./100
3/4	3/8	1	27/8	25/8	5/16	330	56
1	3/8	1	3 1/4	2 15/16	5/16	330	60
1 1/4	3/8	1	3 9/16	3 1/4	5/16	330	74
1 1/2	3/8	1	3 13/16	3 7/16	5/16	330	79
2	3/8	1 1/2	5 1/8	4 5/8	5/16	440	156
2 1/2	1/2	1 3/4	5 5/8	5 3/8	3/8	440	176
3	1/2	1 7/8	6 3/4	6 1/8	3/8	660	198
3 1/2	1/2	2	7 1/4	6 3/4	3/8	660	219
4	5/8	2	8 5/8	7 1/4	1/2	800	288
5	5/8	2	9 7/8	8 5/16	5/8	980	390
6	3/4	2 1/8	10 15/16	9 1/2	5/8	980	448
8	7/8	2 1/8	13 7/16	11 1/2	3/4	1200	691

Fig. 4L Longitudinal "In-Line" Sway Brace Attachment



Size Range — 2½" through 8" IPS.

Material — Carbon Steel

Function — For bracing pipe against sway and seismic disturbance.

Approvals — Underwriter's Laboratories Listed in the USA (**UL**) and Canada (**cUL**) 2½" - 8". Approved by Factory Mutual Engineering (**FM**), 2½" - 8" pipe.

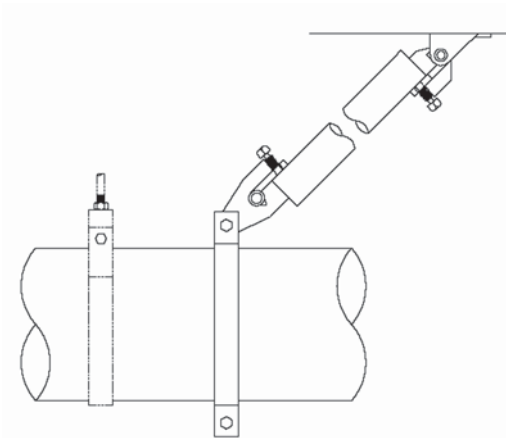
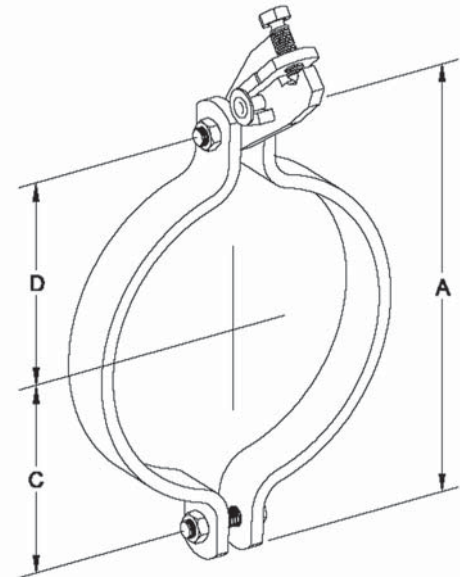
Installation Instructions — The Fig. 4L is the "braced pipe" attachment component of a longitudinal sway brace assembly. It is intended to be combined with the "bracing pipe" and TOLCO structural attachment component to form a complete bracing assembly. NFPA 13 and/or OSHPD guidelines should be followed.

To Install — Place the Fig. 4L over the pipe to be braced and tighten bolts. Then engage "bracing pipe" into jaw opening and tighten set bolt until hex head snaps off. Jaw attachment can pivot for adjustment to proper brace angle.

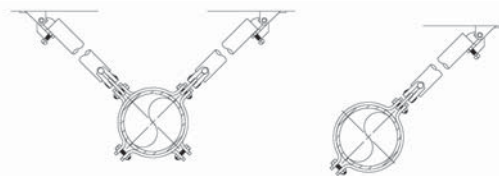
Finish — Plain

Note — Available in Electro-Galvanized and HDG finish.

Order By — Figure number, pipe size and finish.



Longitudinal Brace



4-Way Riser Brace
(Plan view)

Dimensions • Weights

Sizes	A	C	D	Bolt Size	Max. Rec. Load Lbs. (cULus)	*Max Rec. Load Lbs. (FM)	Approx. Wt./100
2½	6 ⁷ / ₁₆	2½	2 ³ / ₄	1/2	2015	3000	253
3	7	2 ³ / ₄	3 ¹ / ₁₆	1/2	2015	1550	268
4	8½	3 ³ / ₈	3 ¹¹ / ₁₆	1/2	2015	1550	348
5	9 ³ / ₄	3 ⁷ / ₈	4 ³ / ₈	1/2	2015	1450	380
6	11½	5	5 ¹ / ₈	1/2	2015	1450	640
8	13 ¹ / ₄	6 ¹¹ / ₁₆	6 ¹ / ₈	1/2	2015	1450	728

* Load shown is allowable with brace installed, between 30° - 90°. No reduction of load based on brace angle is required.

FM approved when used with 1", 1¼", 1½" or 2" Sch. 40 brace pipe.

TOLCO® brand bracing components are designed to be compatible **ONLY** with other TOLCO® brand bracing components, resulting in a Listed seismic bracing assembly. **DISCLAIMER** — NIBCO does **NOT** warrant against the failure of TOLCO® brand bracing components, in the instance that such TOLCO® brand bracing components are used in combination with products, parts or systems which are not manufactured or sold under the TOLCO® brand. NIBCO shall **NOT** be liable under any circumstance for any direct or indirect, incidental or consequential damages of any kind, including but not limited to loss of business or profit, where non-TOLCO brand bracing components have been, or are used.

Fig. 6 - Riser Clamp
Fig. 6F - Felt Lined Riser Clamp
Fig. 6PVC - PVC Coated Riser Clamp

Size Range — (Fig. 6) 1/2" thru 20" pipe
 (Fig. 6F) 1/2" thru 2 1/2" copper tubing
 (Fig. 6PVC) 1/2" thru 6" pipe

Material — Carbon Steel

Insulation Material — (Fig. 6F) 3/16" felt.

Function — Used for supporting vertical piping.

Approvals — Underwriters' Laboratories Listed in the USA (UL), Canada (cUL) 1/2" - 8". Factory Mutual Engineering Approved, 3/4" thru 8".
 Conforms to Federal Specification WW-H-171E, Type 8, 3/4" thru 20" and Manufacturers Standardization Society SP-69, Type 8.

Maximum Temperature — 650°F

Finish — Plain

Note — Available in Electro-Galvanized and HDG finish or Stainless Steel materials.

Order By — (Fig. 6 and Fig. 6PVC) pipe size and finish. (Fig. 6F) copper tube size and finish. (Fig. 6F is available for Iron Pipe Size, consult factory.

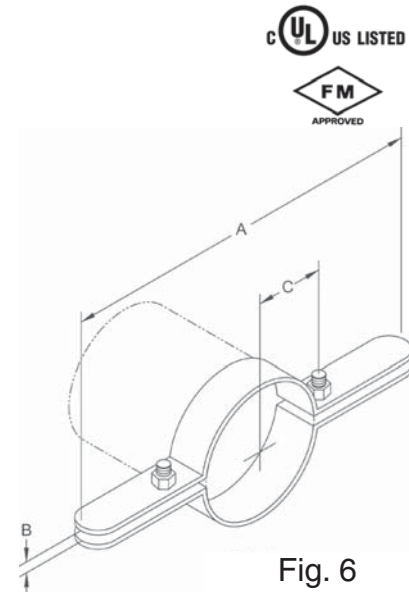


Fig. 6

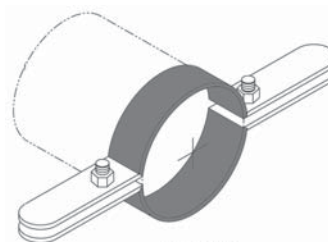


Fig. 6PVC

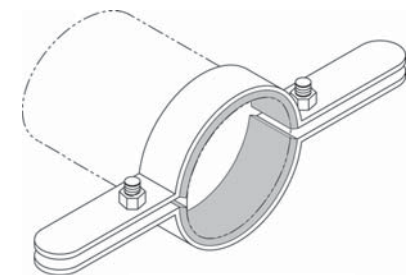


Fig. 6F

Dimensions • Weights

Pipe Size	A	B	C	Bolt Size	Max. Rec. Load Lbs.	Approx. Wt./100
1/2	9 1/4	1/2	1 1/8	3/8	255	144
3/4	9 1/4	1/2	1 1/8	3/8	255	144
1	9 9/16	1/2	1 1/4	3/8	255	147
1 1/4	9 11/16	1/2	1 3/8	3/8	255	150
1 1/2	10 3/8	1/2	1 1/2	3/8	255	153
2	10 3/4	1/2	2	3/8	255	165
2 1/2	11	5/8	2 1/4	3/8	390	228
3	12	5/8	3	3/8	530	246
3 1/2	13	5/8	3 1/4	1/2	670	264
4	13 1/2	3/4	3 3/8	1/2	810	347
5	14 1/2	3/4	4 3/8	1/2	1160	385
6	15 1/8	7/8	4 7/8	1/2	1570	564
8	18 1/2	1	5 3/4	5/8	2500	1017
10	20 1/4	1	7 1/4	5/8	2500	1138
12	22 3/4	1	8 1/4	5/8	2700	1759
14	24	1 1/8	9	5/8	2700	1922
16	26	1 1/8	10 1/4	3/4	2900	3245
18	28	1 1/4	11 1/2	3/4	2900	3372
20	30	1 3/8	12 1/2	3/4	2900	3499

Fig. 22 - Hanger for CPVC Plastic Pipe Single Fastener Strap Type



Size Range — 3/4" thru 2" CPVC pipe

Material — Pre-Galvanized Steel

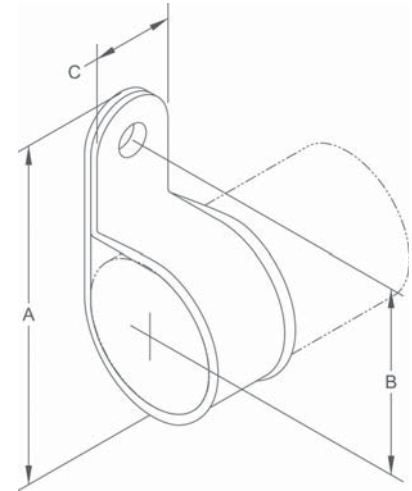
Function — Intended to perform as a hanger to support CPVC piping used in automatic fire sprinkler systems. The product acts as a hanger when tab is upward and the fastener screw is in the horizontal position. Figure 22 can be installed on the top of a beam, but in this situation acts as a guide to the piping which is supported by the beam itself. It is not intended to support CPVC pipe from under a flat horizontal surface, such as a ceiling. For this type of installation, use the TOLCO® Fig. 23, Double Fastener Strap for CPVC Piping. Fig. 22, when inverted, with the hanger tab downward, can function as a restrainer to prevent the upward movement of the sprinkler head during activation.

Approvals — Underwriters' Laboratories Listed in the USA (**UL**) and Canada (**cUL**) to support fire sprinkler piping. May be installed in wood using fasteners supplied with product, or into minimum 20 gauge steel using (1) 1/4" x 1" tek type screw. Meets and exceeds the requirements of NFPA 13, 13R and 13D.

Features — Fig. 22 incorporates features which protect the pipe and ease installation. The flared edge design protects CPVC pipe from any rough surface. It is easily attached to the building structure using the special UL Listed hex head self threading screw furnished with the product, this is the minimum size fastener acceptable. It is recommended that rechargeable electric drills fitted with a hex socket attachment to be used as installation tools. No impact tools (such as a hammer) are allowed. Damage has been known to result from installations using impact type tools. No pre-drilling of a pilot hole in wood is required.

Finish — Pre-Galvanized

Order By — Figure number and CPVC pipe size.



Dimensions • Weights

CPVC Pipe Size	A	B	C	Max. Hanger Spacing (Ft.)	Fastener Hex Head Size	Approx. Wt./100
3/4	27/16	15/16	13/16	5½	5/16	9
1	211/16	17/16	13/16	6	5/16	9
1¼	31/16	15/8	13/16	6½	5/16	11
1½	35/16	1¾	13/16	7	5/16	12
2	3¾	2½	13/16	8	5/16	15

Fig. 23 - Hanger for CPVC Plastic Pipe Double Fastener Strap Type



Size Range — 3/4" thru 3" CPVC pipe

Material — Pre-Galvanized Steel

Function — Intended to perform as a hanger/restrainer to support CPVC piping used in automatic fire sprinkler systems. Fig. 23 can be installed on the top, bottom or side of a beam. The Fig. 23 also functions as a restrainer to prevent the upward movement of the sprinkler head during activation.

Approvals — Underwriters' Laboratories Listed in the USA (**UL**) and Canada (**cUL**) to support fire sprinkler piping. May be installed in wood using fasteners supplied with product, or into minimum 20 gauge steel using (2) 1/4" x 1" tek type screw. Meets and exceeds the requirements of NFPA 13, 13R and 13D.

Features — Fig. 23 incorporates features which protect the pipe and ease installation. The flared edge design protects the CPVC pipe from any rough surface. It also incorporates snap restrainers allowing easier and faster installation. Easily attaches to the building structure using the two UL Listed hex head self threading screws* furnished with the product. It is recommended that rechargeable electric drills fitted with a hex socket attachment be used as installation tools. No impact tools (such as a hammer) are allowed.

Damage has been known

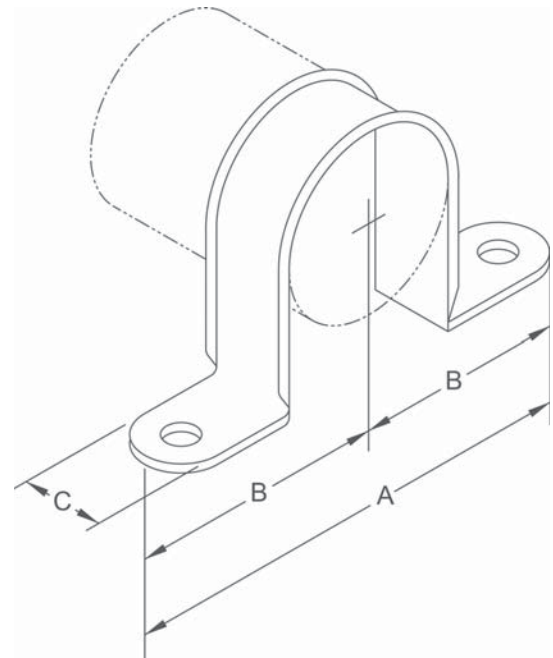
to result from installations using impact type tools.

No pre-drilling of a pilot hole in wood is required.

Finish — Pre-Galvanized

Order By — Figure number and pipe size

* Hardened hex head self threading screw is furnished with the product and is the minimum fastener size acceptable.



Dimensions • Weights

CPVC Pipe Size	A	B	C	Max. Hanger Spacing (Ft.)	Fastener Hex Head Size	Approx. Wt./100
3/4	3 1/8	1 9/16	1 3/16	5 1/2	5/16	9
1	3 3/8	1 11/16	1 3/16	6	5/16	9
1 1/4	4 3/16	2 3/32	1 3/16	6 1/2	5/16	11
1 1/2	4 7/16	2 7/32	1 3/16	7	5/16	12
2	4 7/8	2 7/16	1 3/16	8	5/16	15
2 1/2	10 9/32	2 11/16	1 3/16	9	5/16	22
3	11 7/8	3	1 3/16	10	5/16	25

Fig. 24 - Hanger for CPVC Plastic Pipe Double Fastener Strap Type - Side Mount



Size Range — 3/4" thru 2" CPVC pipe

Material — Pre-Galvanized Steel

Function — Intended to perform as a hanger/restrainer to support CPVC piping used in automatic fire sprinkler systems. Can be installed on the top or on the bottom of a beam. The Fig. 24 can also function as a restrainer to prevent the upward movement of the sprinkler head during activation.

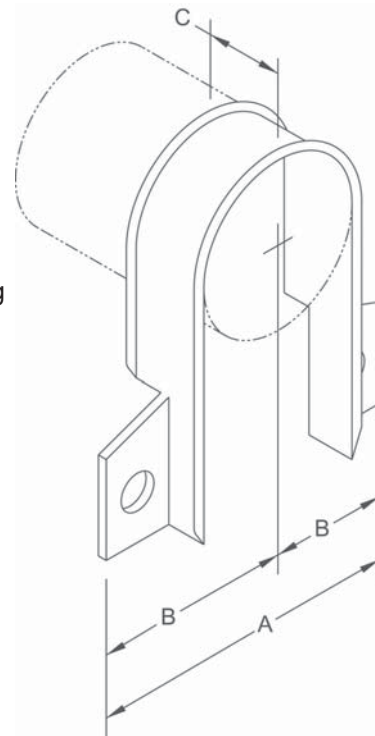
Approvals — Underwriters' Laboratories Listed in the USA (**UL**) and Canada (**cUL**) to support fire sprinkler piping. May be installed in wood using fasteners supplied with product, or into minimum 20 gauge steel using (2) 1/4" x 1" tek type screw. Meets and exceeds the requirements of NFPA 13, 13R and 13D.

Features — Fig. 24 incorporates features which protect the pipe and ease installation. The flared edge design protects the CPVC pipe from any rough surface. Easily attaches to the building structure using the two UL Listed hex head self threading screws* furnished with the product. It is recommended that rechargeable electric drills fitted with a hex socket attachment be used as installation tools. No impact tools (such as a hammer) are allowed. Damage has been known to result from installations using impact type tools. No pre-drilling of a pilot hole in wood is required.

Finish — Pre-Galvanized

Order By — Figure number and pipe size

* **Hardened hex head self threading screw is furnished with the product and is the minimum fastener size acceptable.**



Dimensions • Weights

CPVC Pipe Size	A	B	C	Max. Hanger Spacing (Ft.)	Fastener Hex Head Size	Approx. Wt./100
3/4	2 ⁵ / ₁₆	1 ⁵ / ₃₂	1 ³ / ₁₆	5 ¹ / ₂	5/16	9
1	2 ⁵ / ₈	1 ⁵ / ₁₆	1 ³ / ₁₆	6	5/16	9
1 ¹ / ₄	3	1 ¹ / ₂	1 ³ / ₁₆	6 ¹ / ₂	5/16	11
1 ¹ / ₂	3 ¹ / ₄	1 ⁵ / ₈	1 ³ / ₁₆	7	5/16	12
2	3 ¹¹ / ₁₆	1 ²⁷ / ₃₂	1 ³ / ₁₆	8	5/16	15

Fig. 25 - Surge Restrainer



Size Range — One size fits 3/4" thru 2" pipe.

Material — Pre-Galvanized Steel

Function — Designed to be used in conjunction with TOLCO® Band Hangers to restrict the upward movement of piping as it occurs during sprinkler head activation or earthquake type activity. The surge restrainer is easily and efficiently installed by snapping into a locking position on the band hanger. This product is intended to satisfy the requirements as indicated in the National Fire Protection Association NFPA 13, 2007 edition, 9.2.3.4.4.1 and 9.2.3.4.4.4 Can be used to restrain either steel pipe or CPVC plastic Pipe.

Approvals — Underwriters' Laboratories Listed **only** when used with TOLCO band hangers Fig. 2, 2NFPA and 200, in the USA (**UL**) and Canada (**cUL**).

Finish — Pre-Galvanized

Order By — Figure number and TOLCO band hanger, size from 3/4" thru 2".

Patent #5,344,108

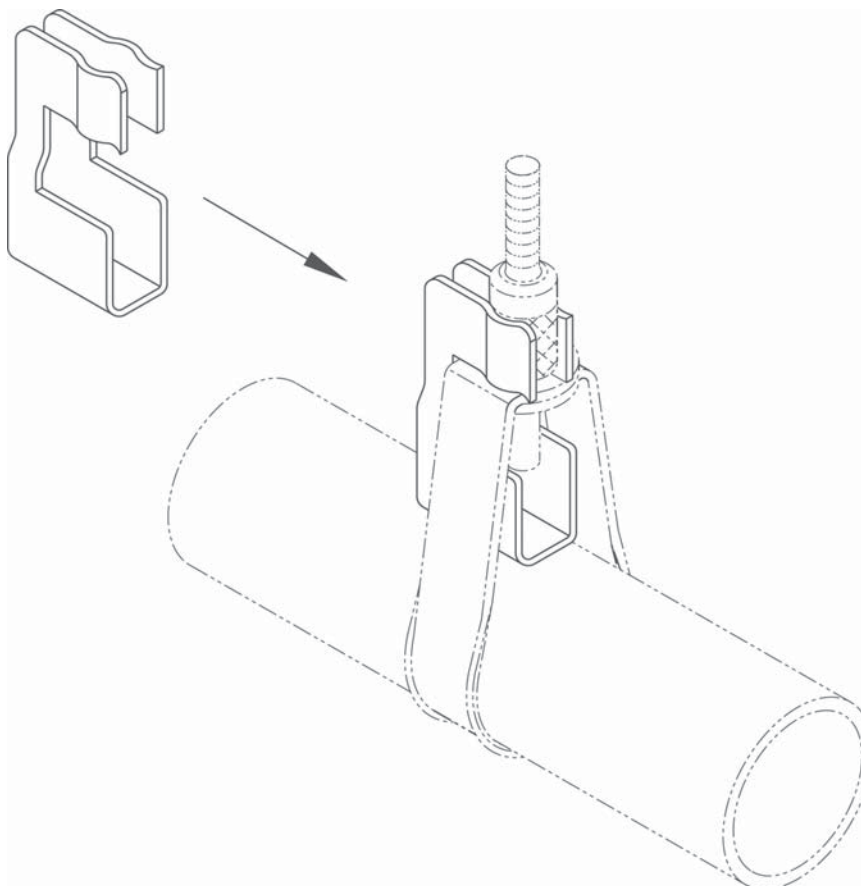
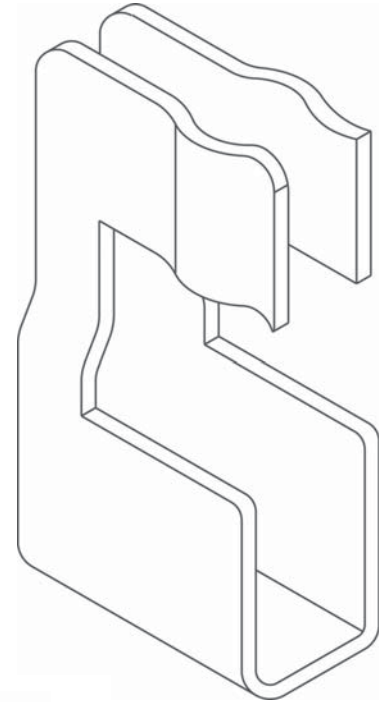


Fig. 28

"Stand-Off" Hanger & Restrainer for CPVC Plastic Pipe



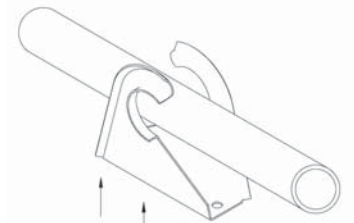
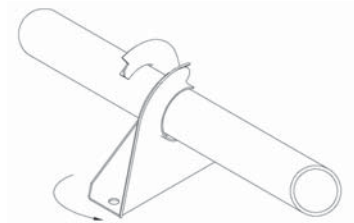
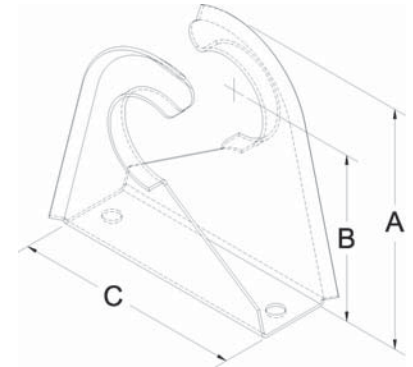
Size Range — 3/4" through 2"

Material — Carbon Steel, Pre-Galvanized

Function — Designed to be used as a hanger and restrainer for CPVC piping where the "stand-off" design will ease installation by eliminating the need for wood blocking.

Features:

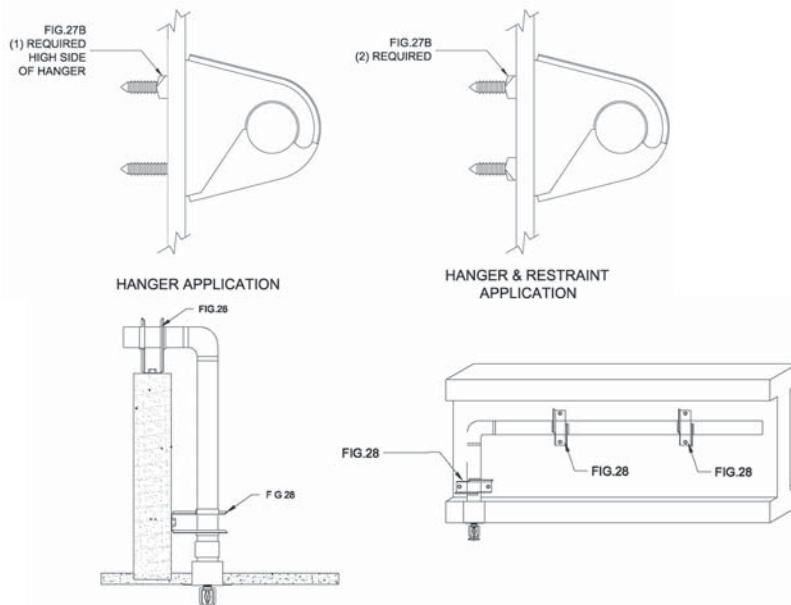
- Flared edge design protects CPVC pipe from any rough or abrasive surfaces.
- Unique twist and lock design holds pipe firmly in place and allows retrofit type of installation.
- The "Stand-Off" design eliminates the need for wood block extension.
- Can be installed on horizontal or vertical piping regardless of mounting surface orientation.
- Attaches easily to wood structure with two hex head self-threading screws furnished with product.
- Installs easily using rechargeable electrical driver with 5/16" extension socket eliminating impact tool damage to pipe.
- Attaches easily to steel, minimum 18 gauge with (2) 1/4" x 1" tek type self drilling tapping screws.
- U.L. Listed as a hanger and a restrainer for fire sprinkler piping.



Approvals — Underwriters' Laboratory Listed in the USA (**UL**) and Canada (**cUL**) to support automatic fire sprinkler systems. May be installed in wood using fasteners supplied with product, or into minimum 18 gauge steel using (2) 1/4" x 1" tek type screws. Meets and exceeds the requirements of NFPA 13, 13R and 13D. Fig. 28 satisfies the UL vertical restraint requirement where needed. UL Listed as a hanger and vertical restraint when installed on 3/8" composite wood material. Use two Fig. 27B Speed Nuts when used as a hanger and restraint. Use one Fig. 27B Speed Nut on the upper installed screw when used as a hanger only.

Order by — Figure number and pipe size.

PATENT # 10446292



Dimensions • Weights

Pipe Size	A	B	C	Approx. Wt.
3/4	3 1/32	2	3 1/2	.180
1	3 5/16	2 3/16	3 1/2	.210
1 1/4	3 5/8	2 3/8	3 1/2	.225
1 1/2	4	2 1/2	3 1/2	.310
2	4 1/2	2 11/16	3 5/8	.340

Fig. 29 - Double Offset Hanger & Restrainer for CPVC Plastic Pipe



Size Range — Available in 3/4" and 1" pipe sizes

Material — Pre-Galvanized Steel

Function — Intended to perform as a hanger and restrainer for CPVC, plastic fire sprinkler pipe. Provides double offset 1 1/2" x 1 1/2" from mounting surface. This design will ease installation by eliminating the need for wood block extension and allow retro-fit attachment of hanger to sprinkler pipe.

Features —

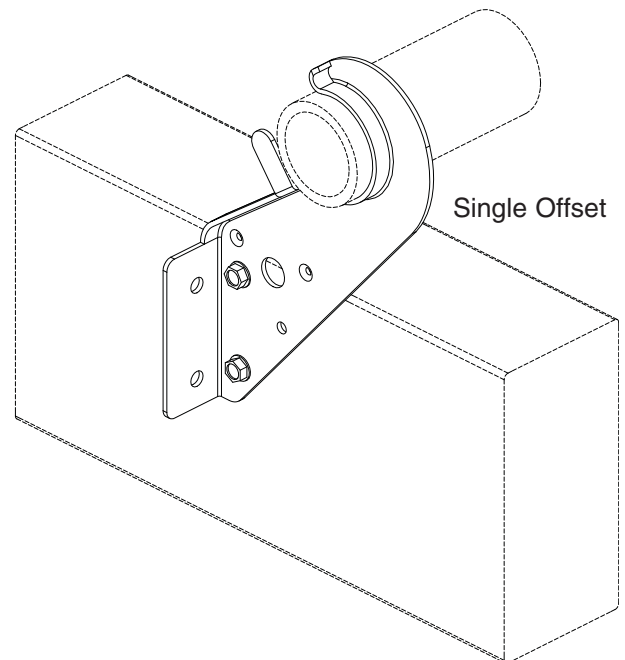
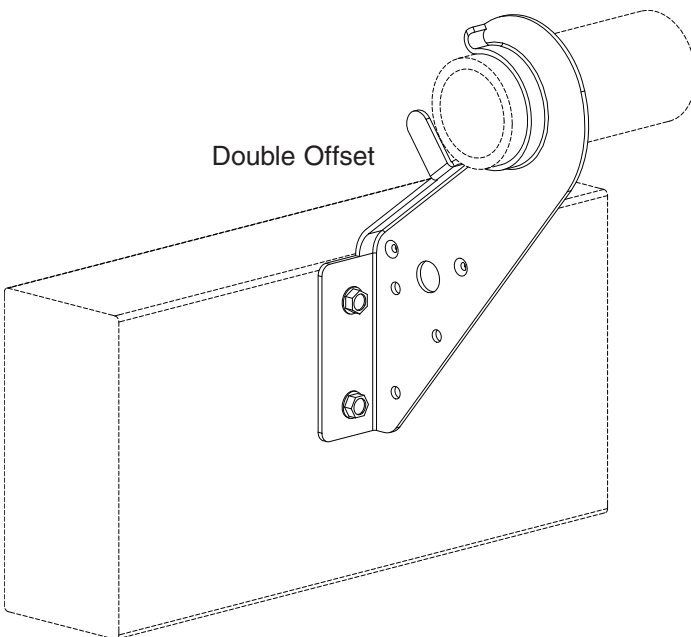
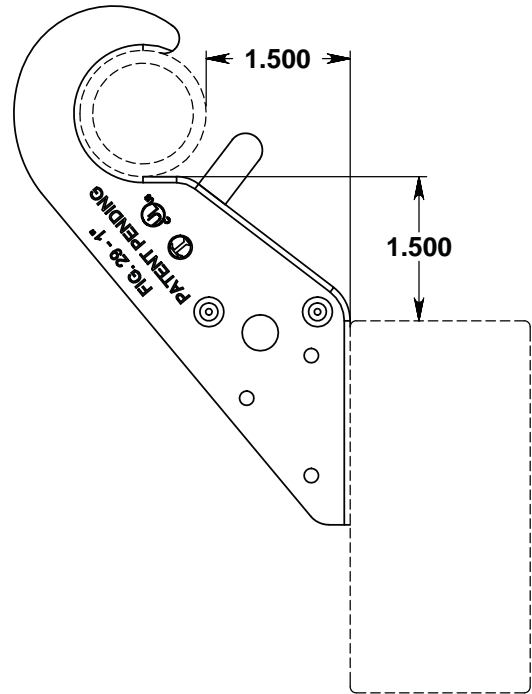
- Thumb tab provides protection to restrain pipe in rough job site conditions. Tab is not required to be bent for listed installation.
- Offset edge eliminates abrasion.
- Attaches easily to wood structure with two special #10 x 1 hex head self-threading screws furnished with product.

Approvals — Underwriters' Laboratories Listed in the USA (**UL**) and Canada (**cUL**) as a hanger and restrainer to support fire sprinkler systems. Meets and exceeds requirements of NFPA 13, 13R and 13D.

Finish — Pre-Galvanized

Order By — Figure number and pipe size.

PATENT PENDING



Install using a rechargeable electric drill fitted with a 5/16" socket attachment with the special hex head self-tapping screws provided. Install screws until they bottom out. Pipe can be "snapped" into hanger before or after installation of the screws to the mounting surface. "Thumb tab" may be bent up to provide additional protection to the pipe, but is not required for performance of the hanger / restrainer function.

Fig. 42 - Angle Bracket

Material — Carbon Steel

Function — Recommended for supporting pipe at various distances from wall or column.

Finish — Plain

Note — Available in Electro-Galvanized and HDG finish or Stainless Steel materials.

Order By — Figure number, size and finish

Dimensions • Weights					
Size	A	B	Hole Size	Max. Rec. Load Lbs.	Approx. Wt./100
1	3	2	7/16	180	46
2	4	3	7/16	180	65
3	3	2	9/16	390	85
4	4	3	9/16	390	115

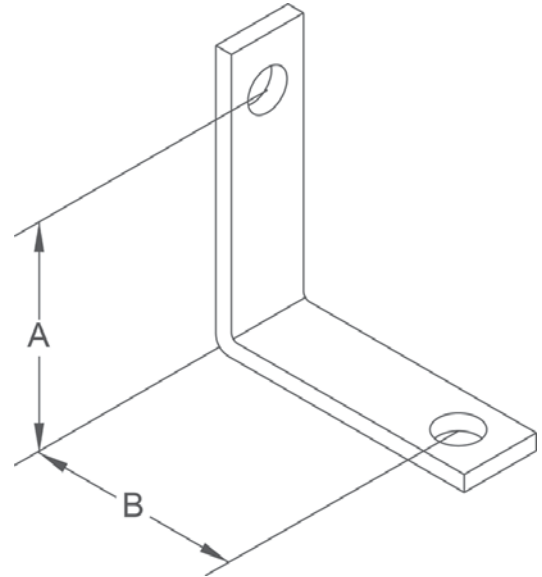


Fig. 50 - Side Beam Bracket

Size Range — 3/8" thru 7/8" rod

Material — Carbon Steel

Function — Recommended for attaching hanger rod to side of beams or walls.

Approvals — 3/8", Underwriters' Laboratories Listed in the USA (UL) and Canada (cUL), and Factory Mutual Engineering approved.

Finish — Plain

Note — Available in Electro-Galvanized and HDG finish or Stainless Steel materials.

Order By — Figure number, rod size and finish

Dimensions • Weights						
Rod Size	A	B	C	Hole Size	Max. Rec. Load Lbs.	Approx. Wt./100
3/8	2	3/4	2	7/16	700	35
1/2	2	3/4	2	9/16	700	35
5/8	2	3/4	2	11/16	700	32
3/4	2½	3/4	2½	13/16	1250	110
7/8	2½	3/4	2½	15/16	1250	100

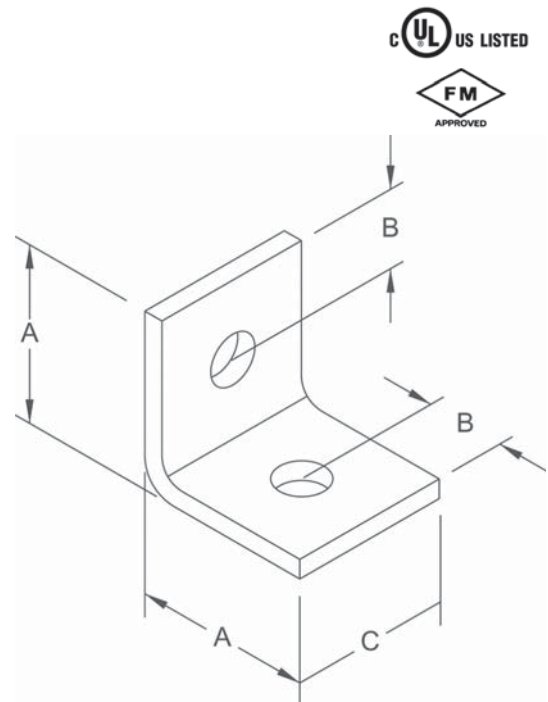


Fig. 51 - Side Beam Bracket for NFPA Rod and Fastener Sizing

Size Range — 3/8" and 1/2" rod, 1/2" thru 8" pipe

Material — Carbon Steel

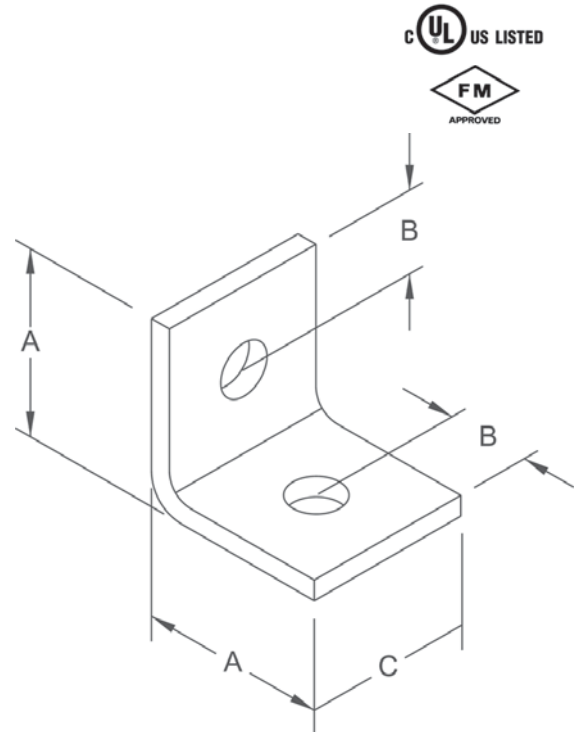
Function — Recommended for attaching hanger rod to side of beams or walls. Designed to accommodate current rod schedule and fastener requirements per National Fire Protection Association (NFPA) Pamphlet 13.

Approvals — Underwriters' Laboratories Listed in the USA (**UL**) and Canada (**cUL**), and Factory Mutual Engineering approved.

Finish — Plain

Note — Available in Electro-Galvanized and HDG finish or Stainless Steel materials.

Order By — Figure number, rod size and finish



Dimensions • Weights

Pipe Size	Rod Size	A	B	C	Hole Size		Max. Rec. Load Lbs.	Approx. Wt./100
					H-1	H-2		
1/2 - 2	3/8	2	3/4	2	7/16	7/16	700	35
2½ - 4	3/8	2	3/4	2	9/16	7/16	700	34
5 - 6	1/2	2½	3/4	2½	9/16	9/16	1250	71
8	1/2	2½	3/4	2½	11/16	9/16	1250	70

Fig. 58 - Threaded Side Beam Bracket

Size Range — 3/8" rod, pipe sizes 1/2" thru 4"

Material — Carbon Steel

Function — Practical and economical bracket used to support piping from wood, concrete or steel beams.

Features — Unique design allows rod to be easily threaded into bracket. Offset design permits unlimited rod adjustment. Center mounting hole will accept 3/8" and 1/2" fastener bolts. Per NFPA 13: 1/2" thru 2" pipe requires 3/8" fastener, 2 1/2" thru 4" pipe requires 1/2" fastener.*

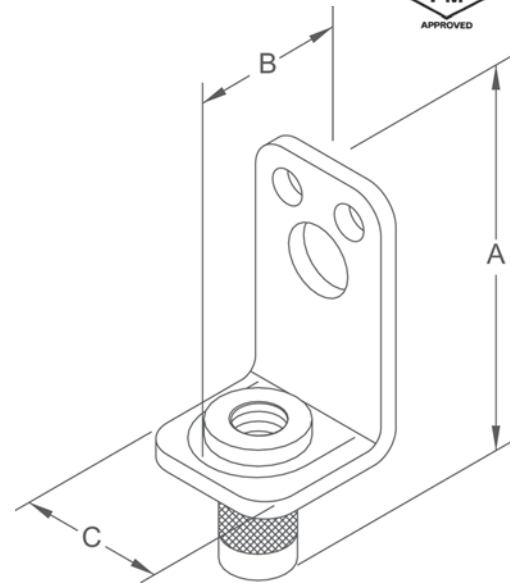
Approvals — Underwriters' Laboratories Listed in the USA (**UL**) and Canada (**cUL**), and Factory Mutual Engineering approved thru 4" pipe.

***Note** — Additionally **UL** has listed the Fig. 58 with fasteners as shown in table below.

Finish — Plain

Note — Available in Electro-Galvanized finish.

Order By — Figure number and finish



UL Listed Fastener Table

Pipe Size	Qty.	Fastener Type	Material
2	2	#16 x 2 Drive Screws	Wood
2	1	3/8 Lag Bolt	Wood
2 1/2 - 4	1	1/2 Lag Bolt	Wood
3 1/2	2	1/4 x 1 1/2 Lag Bolt	Wood
4	2	1/4 x 2 Lag Bolts*	Wood
4	2	1/4 x 1 tek screws	14 gauge
4	2	1/4 x 1 tek screws	16 gauge

* No pre-drilling required

Dimensions • Weights

Pipe Size	Rod Size	A	B	C	Max. Rec. Load Lbs.*	Approx. Wt./100
1/2 thru 4	3/8	2 3/4	1 1/2	1 1/8	300	14

* With safety factor of 5.

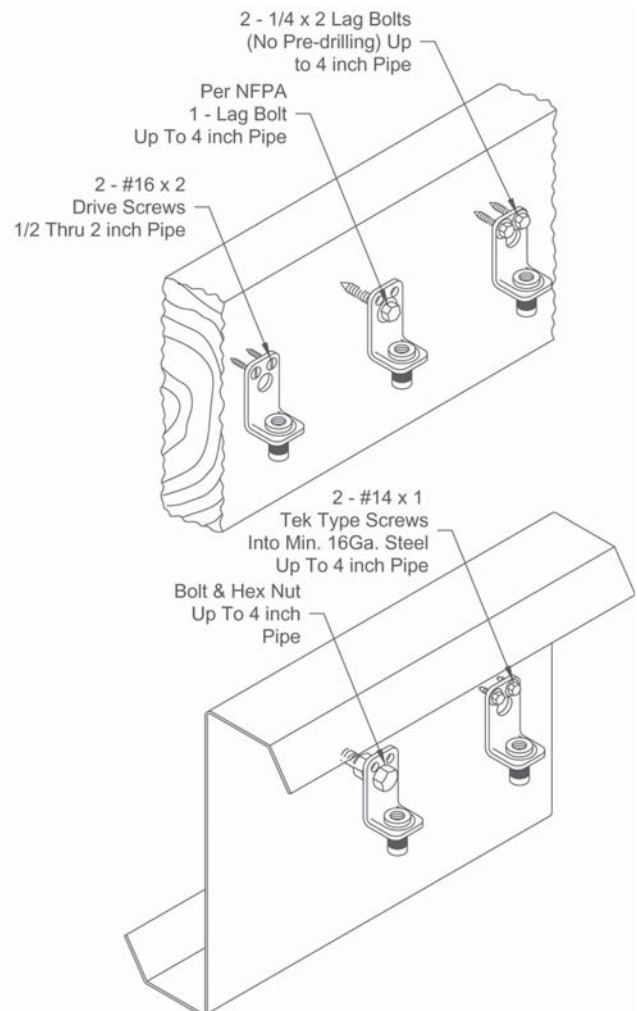


Fig. 61T - Bar Joist Hanger



Size Range — 3/8" thru 1/2" rod sizes

Material — Carbon Steel

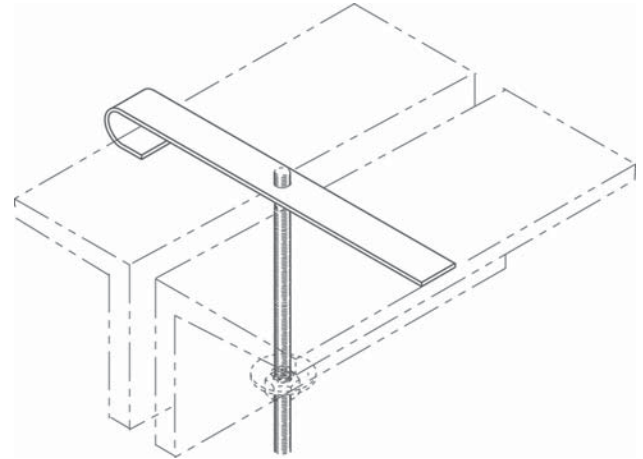
Function — Designed to hook on top chord of metal bar joist. Hanger rod is threaded into product and secured with a washer and nut.

Approvals — Underwriters' Laboratories Listed in the USA (**UL**) and Canada (**cUL**) for up to 4" pipe with 3/8" rod, up to 6" pipe with 1/2" rod.

Finish — Plain

Note — Available in Electro-Galvanized and HDG finish or Stainless Steel materials.

Order By — Figure number, rod size, width and thickness of bar joist. Threaded hole will be center of that width.



Dimensions

Pipe Size	Rod Size	Max. Rec. Load Lbs.
Up to 4"	3/8"	300
6"	1/2"	600

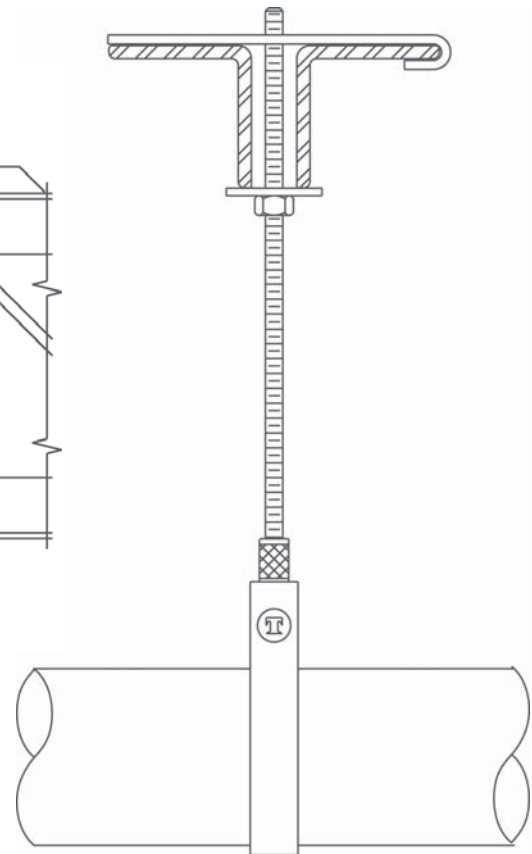
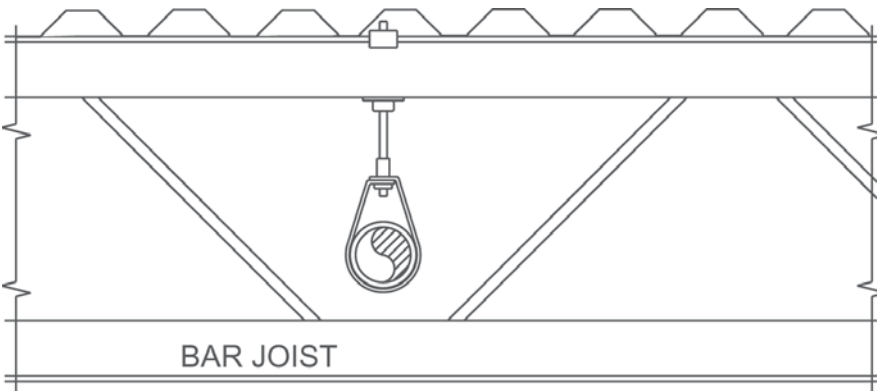


Fig. 65 and Fig. 66 Reversible C-Type Beam Clamps 3/4" and 1 1/4" Throat Openings

Size Range — (Fig. 65 and Fig. 66) 3/8", 1/2" and 5/8" rod

Material — Carbon Steel with hardened cup point set screw and jam nut

Function — Recommended for hanging from steel beam where flange thickness does not exceed 3/4" (Fig. 65) or 1 1/4" (Fig. 66).

Features — All steel construction eliminates structural deficiencies associated with casting type beam clamps. May be used on top or bottom flange of the beam. (Beveled lip allows hanging from top flange where clearance is limited.) May be installed with set screw in up or down position. Offset design permits unlimited rod adjustment by allowing the rod to be threaded completely through the clamp. Open design permits inspection of thread engagement.


Approvals — Underwriters' Laboratories Listed in the USA (**UL**) and Canada (**cUL**). Exceeds requirements of the National Fire Protection Association (NFPA), Pamphlet 13, 3/8" rod will support 1/2" thru 4" pipe, 1/2" rod will support 1/2" thru 8" pipe. Included in our Seismic Restraints Catalog approved by the State of California Office of Statewide Health Planning and Development (OSHPD). For additional load, spacing and placement relating to OSHPD projects, please refer to the TOLCO Seismic Restraint Systems Guidelines.

Finish — Plain

Note — Available in Electro-Galvanized and HDG finish.

Order By — Figure number, rod size and finish

Fig. 65 Patent #4,570,885

Component of State of California OSHPD Approved Seismic Restraints System 

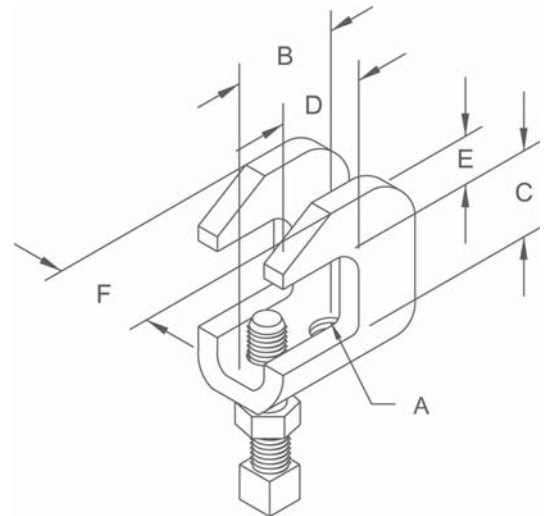


Fig. 65

Dimensions • Weights

Rod Size A	B	C	D	E	F	Max. Rec. Load Lbs.*	Approx. Wt./100
3/8	1 3/16	3/4	1	7/16	1	610	28
1/2	1 1/2	3/4	1	9/16	1 1/4	1130	55
5/8	1 1/2	3/4	1	9/16	1 1/4	1130	55

* Max. loads for clamp with set screw in up or down position.

Fig. 66

Dimensions • Weights

Rod Size A	B	C	D	E	F	Max. Rec. Load Lbs.*	Approx. Wt./100
3/8	1 3/16	1 1/4	1	7/16	1	610	28
1/2	1 1/2	1 1/4	1	9/16	1 1/4	1130	55
5/8	1 1/2	1 1/4	1	9/16	1 1/4	1130	55

* Max. loads for clamp with set screw in up or down position.

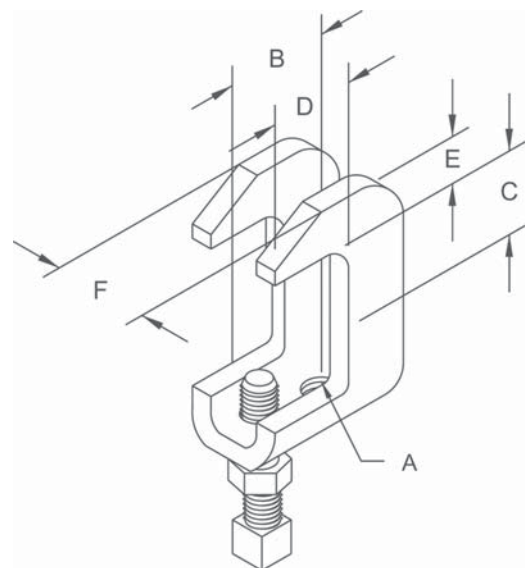


Fig. 67SS and Fig. 68SS Stainless Steel Reversible C-Type Beam Clamps 3/4" Throat Opening/Wide Mouth Stainless Steel



Size Range — 3/8" and 1/2" rod sizes

Material — All Stainless Steel (T-316 or T-304)

Function — Recommended for hanging from steel beams where flange thickness does not exceed 3/4" (Fig. 67SS) or 1 1/4" (Fig. 68SS).

Features — All steel construction eliminates structural deficiencies associated with casting type beam clamps. May be used on top or bottom flange of the beam. May be installed with the set screw in up or down position. Offset design permits unlimited rod adjustment by allowing the rod to be threaded completely through the clamp.

Approvals — Underwriters' Laboratories Listed in the USA (UL) and Canada (cUL). Conforms to Manufacturers' Standardization Society SP-69, Type 19. Meets or exceeds requirements of the National Fire Protection Association (NFPA), pamphlet 13, 3/8" rod will support 1/2" through 4" pipe, 1/2" rod will support 1/2" through 8" pipe.

Order By — Figure number and rod size

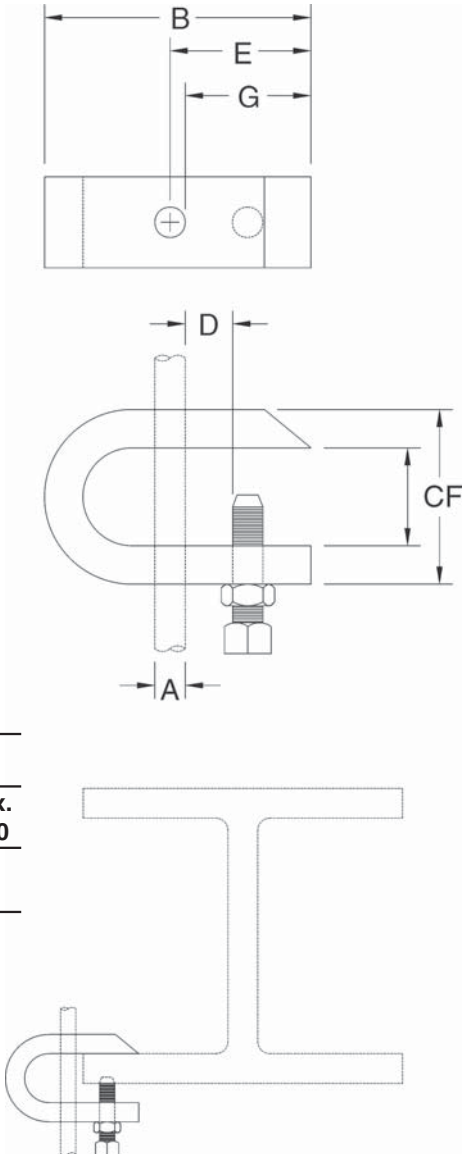


Fig. 67SS

Dimensions • Weights

Pipe Size	A	B	C	D	E	F	G	Stock Size	Test Load	Approx. Wt./100
1/2 - 4	3/8	3	7/8	1	1 5/8	1 5/8	1 1/8	5/16 x 1	1500 lbs.	68
5, 6, 8	1/2	3	7/8	1	1 5/8	1 5/8	1 1/8	3/8 x 1 1/2	4050 lbs.	107

Fig. 67SS

Fig. 68SS

Dimensions • Weights

Pipe Size	A	B	C	D	E	F	Stock Size	Test Load	Approx. Wt./100
1/2 - 4	3/8	2 1/16	2	3/4	1 1/4	1 1/8	3/8 x 1 1/2	1500 lbs.	84
5, 6, 8	1/2	2 1/4	2 1/4	13/16	1 1/4	1 1/4	1/2 x 2	4050 lbs.	170

Fig. 69 - Beam Clamp Retaining Strap

 Component of State of
 California OSHPD Approved
 Seismic Restraints System


Size Range — 3/8" thru 7/8" rod by 4" thru 16" length.*

Material — Pre-Galvanized Steel

Function — To offer more secure fastening of various types of beam clamps to beam where danger of movement might be expected. NFPA 13 requires the use of retaining straps with all beam clamps installed in earthquake areas. Satisfies requirements of NFPA 13 (1999) 6-4.7.1.

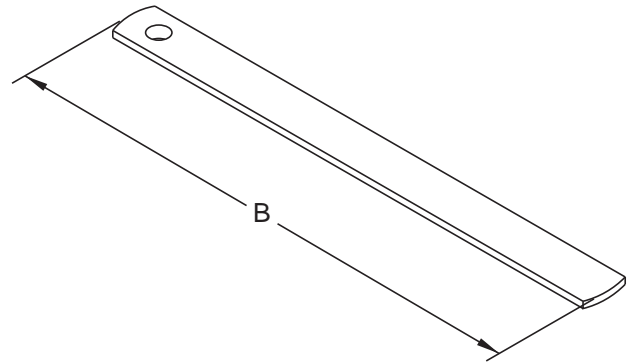
Important Note — Good installation practice of a retaining strap requires that the strap be held tightly and securely to all component parts of the assembly. Therefore a locking mechanism of some kind such as a hex nut or the beveled locking slot on the TOLCO® Fig. 69R will provide a more secure reliable installation.

Approvals — Underwriters' Laboratories listed in the USA (**UL**) and Canada (**cUL**). Approved for use with any listed beam clamp. Included in our Seismic Restraints Catalog approved by the State of California Office of Statewide Health Planning and Development (**OSHPD**). For additional load, spacing and placement information relating to OSHPD projects, please refer to the TOLCO Seismic Restraint Systems Guidelines.

Finish — Pre-Galvanized

Order By — Figure number, type, length "B" and rod size being used with beam clamp

Note — Minimum return on Strap: 1".



Dimensions			
Type	Rod Size A	Hole Size	B
1	3/8	7/16	Specify
	1/2	9/16	Specify
2	5/8	11/16	Specify
	3/4	13/16	Specify
3	3/8 - 7/8	Specify	Specify

* Longer lengths are available, consult factory.

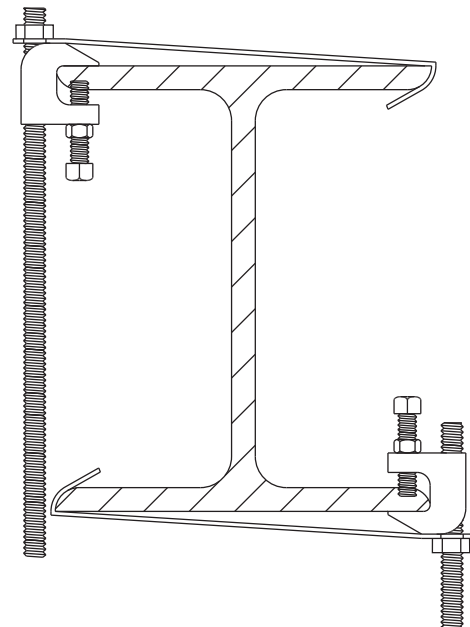



Fig. 69R - Retrofit Capable Beam Clamp Retaining Strap

 Component of State of California OSHPD Approved Seismic Restraints System 

Size Range — 3/8" and 1/2" rod; 4" thru 16" length.**

Material — Pre-Galvanized Steel

Function — To offer more secure fastening of various types of beam clamps to beam where danger of movement might be expected. NFPA 13 requires the use of retaining straps with all beam clamps installed in earthquake areas. Satisfies requirements of NFPA 13 (1999) 6-4.7.1.

Features — Beveled locking slot* is precisely formed to align with the threaded section of a hanger rod or set screw and engage the unit securely. May be used as shown in section "A-A" or inverted. Allows easy installation for new construction or retrofit applications.

Important Note — Good installation practice of a retaining strap requires that the strap be held tightly and securely to all component parts of the assembly. Therefore a locking mechanism of some kind, such as the beveled locking slot of the Fig. 69R or a hex nut tightened against other types of retaining straps will provide a more secure and reliable installation.

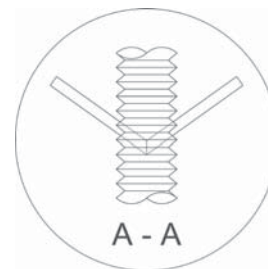
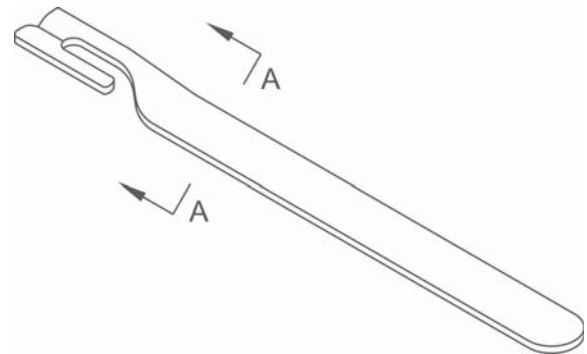
Approvals — Underwriters' Laboratories listed in the USA (**UL**) and Canada (**cUL**). Approved for use with any listed beam clamp. Included in our Seismic Restraints Catalog approved by the State of California Office of Statewide Health Planning and Development (OSHPD). For additional load, spacing and placement information relating to OSHPD projects, please refer to the TOLCO Seismic Restraint Systems Guidelines.

Finish — Pre-Galvanized

Order By — Figure number, rod or set screw size and length

Note — Minimum return on Strap: 1".

* Patent #5,947,424



Dimensions

Rod Size A	Length
3/8"	Specify
1/2"	Specify

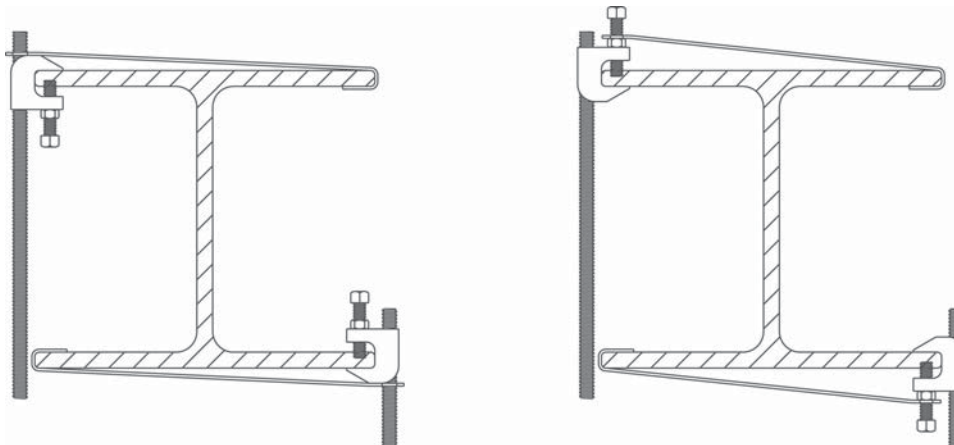


Fig. 75 - Swivel Attachment



Size Range — 3/8" Rod Attachment

Material — Carbon Steel

Function — There are three recommended applications for this product: May be used as a Branch Line Restraint for structural attachment to anchor bolt, beam clamp, etc. May be used in a pitched or sloped roof application, to meet requirements of NFPA 13 (2002) Sec 9.1.2.5. May be used as an upper attachment with short hanger rod to omit seismic bracing (per UBC97).

Approvals — Underwriters' Laboratories Listed in the USA (**UL**) and Canada (**cUL**) to support up to 4" pipe. Meets requirements of Uniform Building Code (UBC) 1997 Table O, Section 3.B.

Finish — Electro-Galvanized

Order By — Figure number

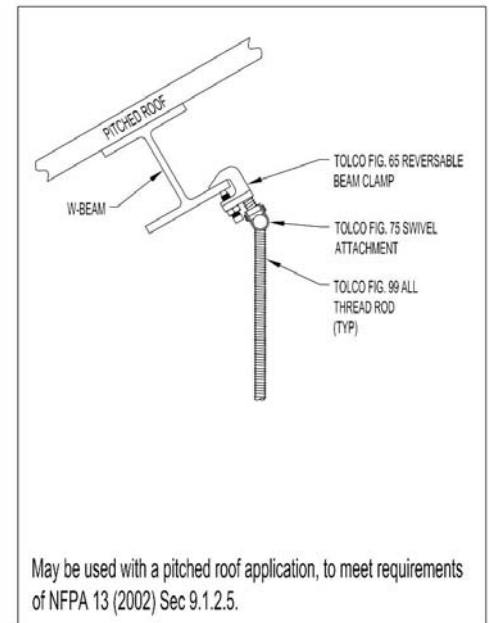
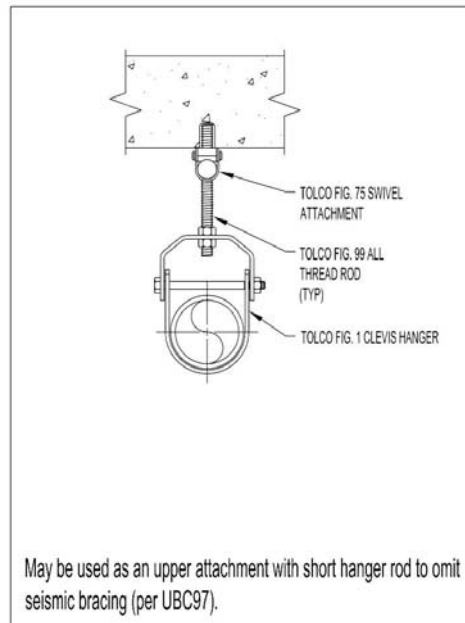
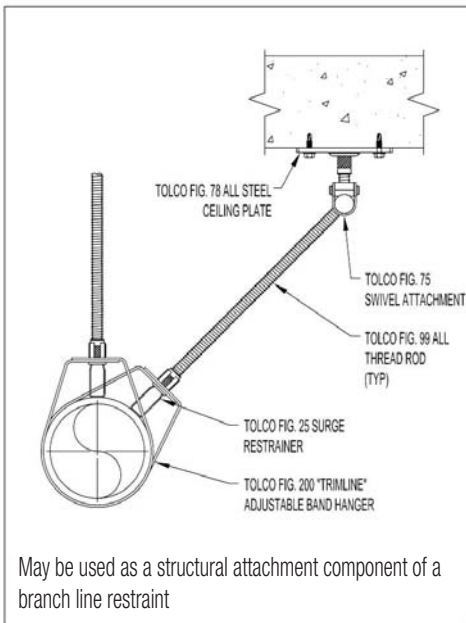
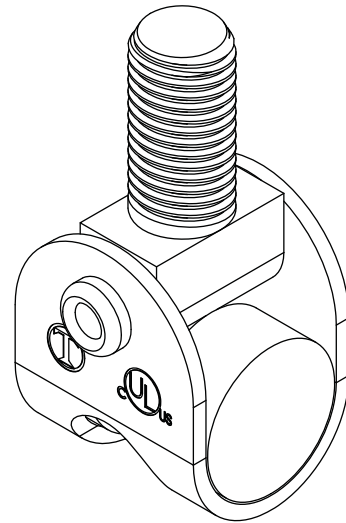




Fig. 78 - All Steel Ceiling Plate

Size Range — 3/8" rod

Material — Carbon Steel

Features — Attachment to wood beams, ceilings, metal decks or walls. Can also be welded to steel beams.

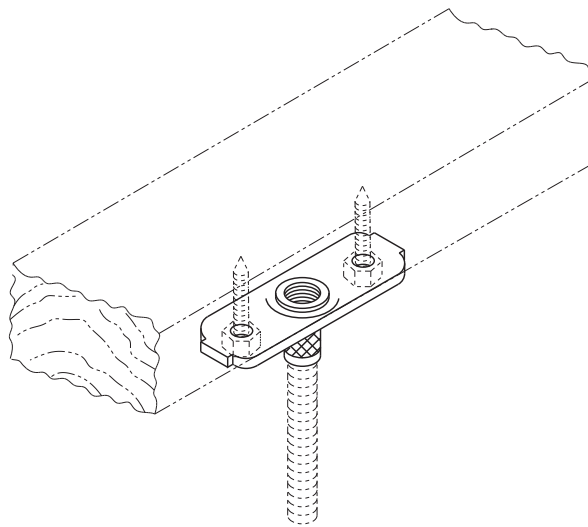
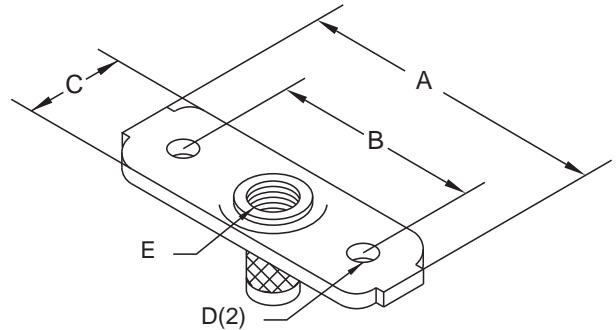
Approvals — Underwriters' Laboratories Listed in the USA (**UL**) and Canada (**cUL**). Additionally, (**UL**) has listed the Fig. 78 with fasteners as shown in the table below.

Finish — Plain and Electro-Galvanized

Note — Available in Electro-Galvanized and HDG finish.

Order By — Figure number, rod size and finish

Patent #5,702,077



UL Listed Fastener Table

Pipe Size	Qty	Fastener Type	Material
1/2 - 2	2	#14 x 1 1/4 A-point hex-washer-head sheet metal screw	Wood
2 1/2 - 4	2	1/4 x 1 1/2 wood screws*	Wood
1/2 - 2	2	1/4 x 1 tek screws	Metal (18 gauge)
1/2 - 2	2	#14 x 1 1/4 A-point hex-washer-head sheet metal screw	Wood
1/2 - 2	2	#14 x 2 A-point-hex-washer-head sheet metal screw	Wood thru 5/8" gyp board

* No pre-drilling

Dimensions • Weights

Pipe Size	A	B	C	D	E	Max. Rec. Load Lbs.*	Approx. Wt./100
1/2 - 2	3	2 1/8	1 1/8	5/16	3/8	150	15
5 - 6	Consult factory for data						

* Minimum safety factor of 5

Fig. 98 - Rod Stiffener

Size Range — Secures 3/8" thru 7/8" hanger rod

Material — Carbon Steel

Function — Secures channel to hanger rod for vertical seismic bracing.

Approvals — Included in our Seismic Restraints Catalog approved by the State of California Office of Statewide Health Planning and Development (OSHPD). For additional load, spacing and placement information relating to OSHPD projects, please refer to the TOLCO Seismic Restraint Systems Guidelines

Finish — Electro Galvanized

Note — Available in HDG finish or Stainless Steel materials.

Order By — Figure number

Component of State of California OSHPD Approved Seismic Restraints System

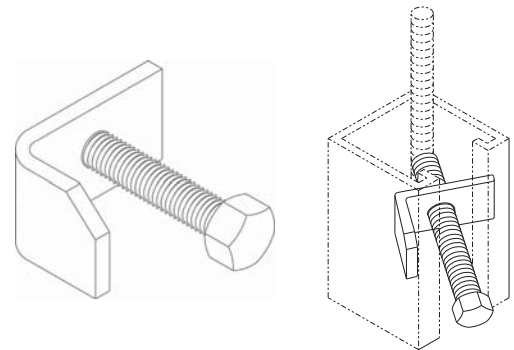


Fig. 99 - All Thread Rod Cut to Length

Size Range — Secures 3/8" thru 7/8" rod in 1" increments

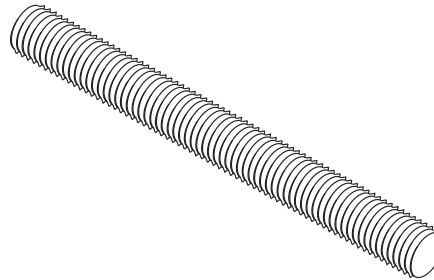
Material — Carbon Steel

Maximum Temperature — 750°F

Finish — Plain

Note — Available in Electro-Galvanized and HDG finish or Stainless Steel materials.

Order By — Figure number, rod diameter, rod length and finish



Dimensions	
Rod Size	Max. Rec. Load Lbs. For Service Temp 650°F
3/8	730
1/2	1350
5/8	2160
3/4	3230
7/8	4480

Fig. 100 - All Thread Rod Full Lengths

Size Range — Secures 3/8" thru 1½" rod in 10' lengths

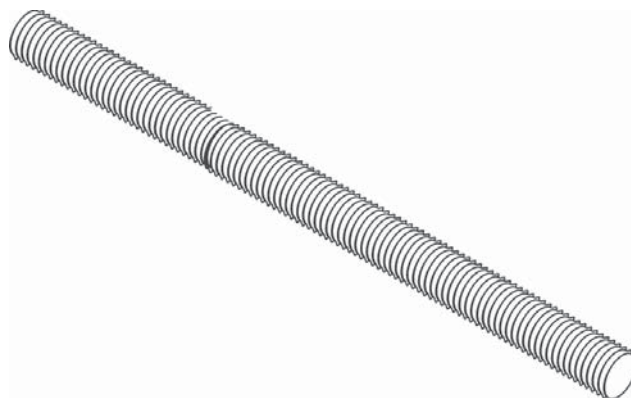
Material — Carbon Steel

Maximum Temperature — 750°F

Finish — Plain

Note — Available in Electro-Galvanized and HDG finish or Stainless Steel materials.

Order By — Figure number, rod diameter and finish



Dimensions • Weights		
Rod Size	Max Rec. Load Lbs. For Service Temps 650°F	Approx. Wt./100
1/4	240	12
3/8	730	29
1/2	1350	53
5/8	2160	84
3/4	3230	123
7/8	4480	169
1	5900	222
1¼	9500	360
1½	13800	510

Fig. 109A - "NFPA" Concrete Deck Insert



Size Range — 3/8" thru 7/8" rod

Material — Carbon Steel

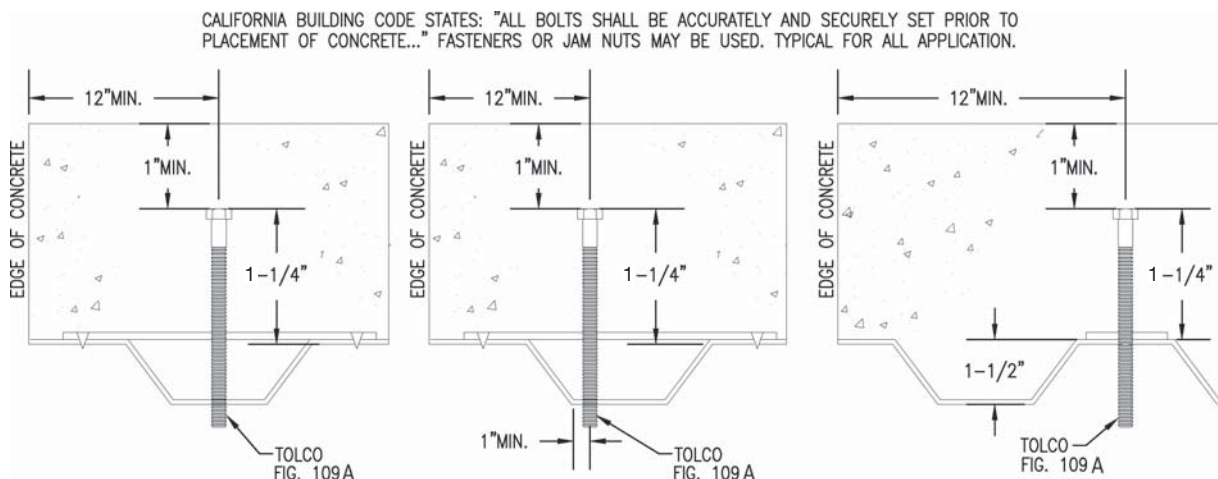
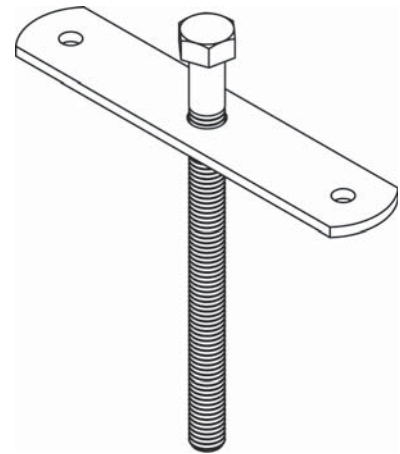
Function — For use in metal deck formed concrete to attach hanger rods. Allows for pre-positioning of hanger rods in poured concrete decks.

Approvals — 3/8" - 5/8" rod size is Underwriters' Laboratories listed in the USA (**UL**) and Canada (**cUL**). Hangers certified by a registered professional engineer to conform to Section 6-1.1 of NFPA #13 (1999) and Section 9.1.1.2 of NFPA 13 (2002).

Finish — Plate: Plain Steel. Rod: Electro-Galvanized.

Note — Available in HDG finish or Stainless Steel materials.

Order By — Figure number, rod size and finish. Custom rod lengths are available. Consult factory.



Spacing/Load Chart for 3000 PSI Light Weight Concrete over 20 GA Steel Deck

Rod Size	Max. Pipe Size	Max. Hanger Spacing	Max. Rec Loads
3/8	4"	15'-0"	1144
1/2	8"	15'-0"	1158
5/8	Consult Factory	Consult Factory	1430
3/4	Consult Factory	Consult Factory	2000
7/8	Consult Factory	Consult Factory	2000

Max. Rec. Loads shown include safety factory of 5.

3/8" - 4" Schedule 40 pipe incl. water wt. = 16.4 lb./ft. x 15 ft. - 246 x 5 (safety factor) + 250 = 1480 lbs.

1/2" - 8" Schedule 40 pipe incl. water wt. - 50.15 lb./ft. x 15 ft. - 752.25 x 5 (safety factor) + 250 = 4011.25 lbs.

NOTES:

1. Mounting holes are standard. If the plate is not mechanically secured to the deck ribs, a jam nut is required to prevent the anchor bolt from laying over when concrete is poured.
2. Minimum spacing between inserts shall be not less than 4 1/2" for 3/8" and 6" for 1/2"

Fig. 109AF - Concrete Insert

Size Range — 3/8" thru 7/8" rod

Material — Carbon Steel

Function — Designed to be embedded in concrete to provide a point of attachment for hanger or seismic bracing.

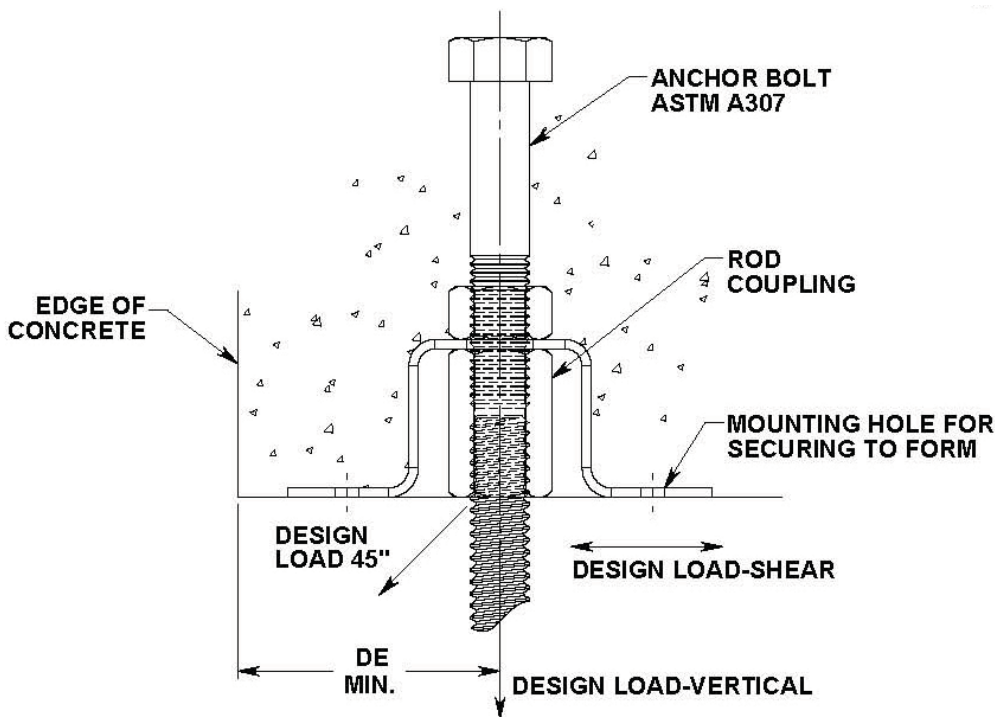
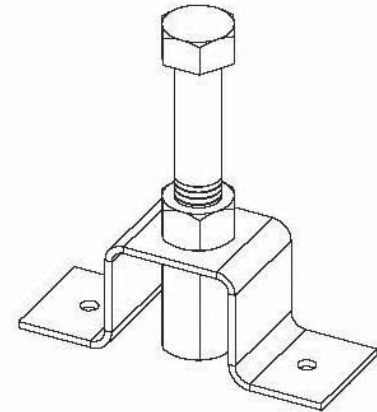
Approvals — Underwriters' Laboratories listed in the USA (**UL**) and Canada (**cUL**) for 3/8" and 1/2". Included in our Seismic Restraints Catalog approved by the State of California Office of Statewide Health Planning and Development (**OSHPD**). For additional load, spacing and placement information relating to OSHPD projects, please refer to the TOLCO Seismic Restraint Systems Guidelines.

Finish — Plain anchor bolt with Electro-Galvanized hardware and plate.

Note — For rod sizes 5/8" - 1 1/2" refer to Fig. 107F. Available in Stainless Steel or HDG finish on request.

Order By — Figure number, rod size and finish.

Note — The Hex or Jam Nut has NO value in determining the loads. Their function is to assist in locking the Coupling snug to the bottom of the deck form preventing the concrete from leaking into the coupling threads. Any other suitable locking device may be substituted if desired.



Dimensions

Rod Size	Design Load Vertical		Design Load Shear		Design Load 45°		"E" Embedment Depth	De min. (in.)
	Hard Rock	Lt. Wt.	Hard Rock	Lt. Wt.	Hard Rock	Lt. Wt.		
3/8	1255	735	978	733	777	525	3 1/2	2
1/2	2321	1392	978	733	980	679	3 1/2	2
5/8	780	468	1278	958	688	445	4	2
3/4	1346	806	1278	958	927	619	4	2 1/2
7/8	2321	1392	1278	958	1166	803	4	6

Fig. 120 - "U" Hanger

Size Range — Size 3/4" thru 8" pipe

Material — Carbon Steel

Function — Used to support piping from wood beams where no contraction is expected. Used extensively in automatic fire sprinkler systems.

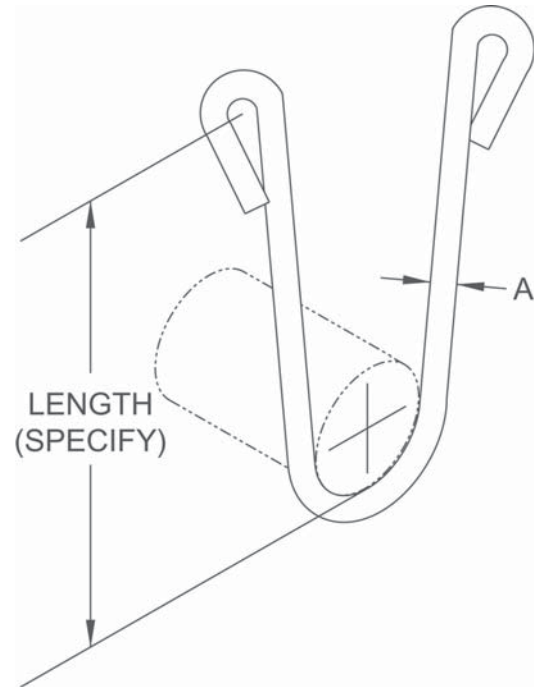
Approvals — Meets or exceeds the requirements of National Fire Protection Association (NFPA), Pamphlet 13. Underwriters Laboratories Listed in the USA (UL) and Canada (cUL). Included in our Seismic Restraints Catalog approved by the State of California Office of Statewide Health Planning and Development (OSHPD). For additional load, spacing and placement information relating to OSHPD projects, please refer to the TOLCO Seismic Restraint Systems Guidelines.

Maximum Temperature — 750°F

Finish — Plain

Note — Available in Electro-Galvanized and HDG finish or Stainless Steel materials.

Order By — Figure number, pipe size, length and finish



Dimensions			
Pipe Size	A	Fastener Size	Max Rec. Load Lbs.***
3/4	5/16	16 x 2*	250
1	5/16	16 x 2*	250
1 1/4	5/16	16 x 2*	250
1 1/2	5/16	16 x 2*	250
2	5/16	16 x 2*	250
2 1/2	3/8	3/8 x 2 1/2**	320
3	3/8	3/8 x 2 1/2**	320
3 1/2	3/8	3/8 x 2 1/2**	560
4	3/8	1/2 x 3**	560
5	1/2	1/2 x 3**	560
6	1/2	1/2 x 3**	760
8	1/2	5/8 X 3**	

* Drive screw

** Lag bolt

*** With minimum safety factor of 5
Fastener schedule per NFPA

Fig. 120MJ - Mutt & Jeff "U" Hanger

Size Range — Size 3/4" thru 8" pipe

Material — Carbon Steel

Function — Used to support piping from wood beams where no contraction is expected. Used extensively in automatic fire sprinkler systems. The Mutt & Jeff is used when the wood beam is on a diagonal.

Finish — Plain

Note — Available in Electro-Galvanized and HDG finish or Stainless Steel materials.

Order By — Figure number, pipe size, side length and finish

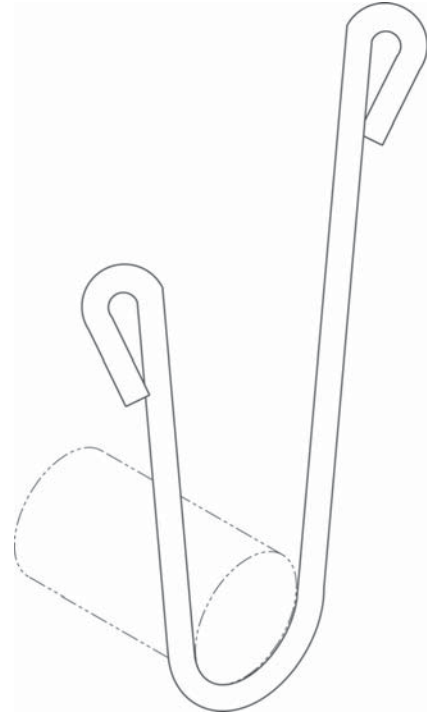


Fig. 120W - Wrap Around "U" Hanger

Size Range — Size 3/4" thru 2" pipe

Material — Carbon Steel

Function — Required for automatic fire protection agencies to be used on the end of branch lines to prevent pipe from whipping vertical and striking ceiling or beam

Finish — Plain

Note — Available in Electro-Galvanized and HDG finish or Stainless Steel materials.

Order By — Figure number, pipe size, length and finish

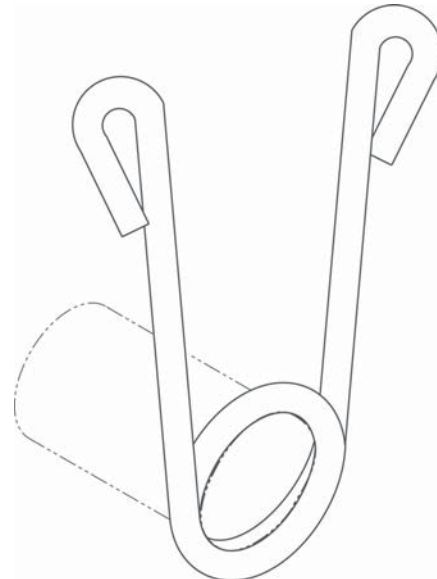


Fig. 120RWA (Model B) Retrofit Wrap Around U-Hanger Clamp

Component of State of
California OSHPD Approved
Seismic Restraints System



Size Range — 1" thru 8" pipe

Material — Carbon Steel

Function — Clamp Model "B" is designed to restrain movement of the pipe within standard U-hangers as is required by NFPA 13. Where retrofit capability is crucial, the Fig. 120RWA is a labor efficient alternative to the standard TOLCO[®] Fig. 120W Wrap Around U-Hanger.

Features — Installs easily by tightening two hex nuts. Features a unique bracing slot that locks onto a standard U-hanger to become a solid unit that will stabilize the pipe during seismic activity or sprinkler head activation. Designed to be used in retrofit or new construction applications. Will clamp to existing U-Hangers without restriction to leg angle

Approvals — Underwriters' Laboratories listed in the USA (**UL**) and Canada (**cUL**) as a restrainer. Included in our Seismic Restraints Catalog approved by the State of California Office of Statewide Health Planning and Development (OSHPD). For additional load, spacing and placement information relating to OSHPD projects, please refer to the TOLCO Seismic Restraint Systems Guidelines. NFPA 13 (1999) A-6-2.3.3.

Finish — Plain and Galvanized. Consult factory for Stainless Steel material.

Order By — Figure number, type numbers and pipe size

Ordering Note — Order by the following type and pipe size:

- Type 1 — (1" and 1¼" pipe size)
- Type 2 — (1½" and 2" pipe size)
- Type 3 — (2½" and 3" pipe size)
- Type 4 — (4" pipe size)
- Type 6 — (5" and 6" pipe size)
- Type 8 — (8" pipe size)

Important Note — The bracing slot feature is sized to fit the U-Hanger rod schedule as required by NFPA 13 as follows:

- 5/16" rod for up to 2" pipe
- 3/8" rod for 2½" - 6" pipe
- 1/2" rod for 8" pipe

For other rod size requirements consult factory.

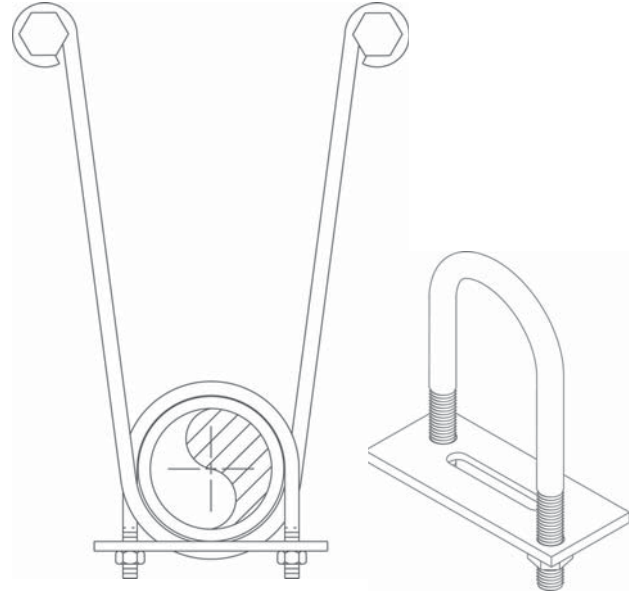


Fig. 130 - Beam Clamp with Bolt and Nut

Size Range — Fig. 130-1 = TJI 35
 Fig. 130-2 = —
 Fig. 130-3 = TJI 25
 Fig. 130-4 = TJI 55 & 65
 Fig. 130-5 = TJI 75
 Fig. 130-6 = TJI 96

Material — Carbon Steel

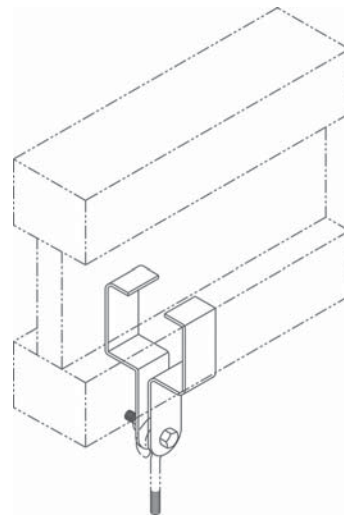
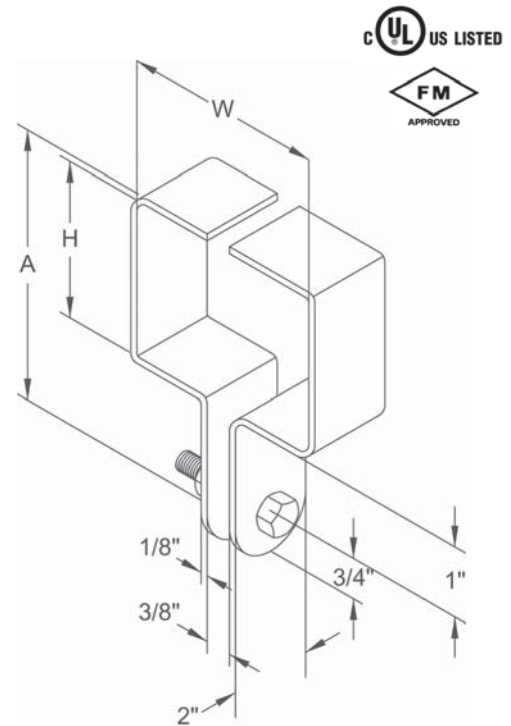
Function — Effective and economical method of hanging from “Trus Joist” type beams. Use with Fig. 102 Eye Rod.

Approvals — Sizes 1, 2, 3 and 4 Underwriters’ Laboratories listed in the USA (**UL**) and Canada (**cUL**) listed through 4" pipe. All Fig. 130 Beam Clamps meet requirements of Factory Mutual Engineering and NFPA 13, through 4" pipe.

Finish — Electro-Galvanized

Note — Available in HDG finish or Stainless Steel materials.

Order By — Figure number with dash designation and finish or by height and width of beam and finish.



Dimensions • Weights

Size 130-	A	Beam Dimensions		Approx. Wt./100
		H	W	
1	3/4	1 1/2	2 5/16	65
2	3 1/2	1 3/4	2 1/2	70
3	3 3/4	1 1/2	1 3/4	58
4	3 1/2	1 1/2	3 1/2	83
5†	3 5/8	1 3/4	3 1/2	86
6†	4 1/2	2 1/2	3 7/8	101

* Max. Rec. Load 500 lbs.

**Safety Factor of 5

† Larger bolts and I-rods are required for 5" and 6" pipe sizes



Fig. 150 - "Wing-It" Concrete Deck Insert

Size Range — 3/8" through 7/8".

Material — Carbon Steel with plastic vinyl thread protector.

Function — For use in metal deck formed concrete, to attach hanger rods or seismic bracing attachments; Allows for pre-positioning of anchor in poured concrete decks.

Features — Fast attach to various size and shaped holes, all steel solid secure attachment, narrow diameter allows closer placement, can be converted to steel stud for flush mount applications such as seismic bracing attachments.

Approvals — Included in our (OSHPD) Pre-Approved Seismic Bracing Guidelines for 2008, U.L. Listed; 3/8" up to 4" pipe size, 1/2" up to 8" pipe size. Factory Mutual Approved; 3/8" up to 4" pipe size, 1/2" up to 8" pipe size.

Finish — Electro-Galvanized.

Order By — Figure number and size.

Dimensions • Loads

Anchor Size	Anchor Location On Flute	Embed. Depth	Min. Insert Spacing	Min. Edge Distance	Tension Load T allow*	Shear Load V allow*
3/8"	Upper	2"	4 1/2"	12"	935	940
3/8"	Lower	2"	4 1/2"	12"	705	940
1/2"	Upper	2"	6"	12"	980	1330
1/2"	Lower	2"	6"	12"	705	1330
5/8"	Upper	2"	7 1/2"	12"	1030	1330
5/8"	Lower	2"	7 1/2"	12"	705	1330
3/4"	Upper	2"	9"	12"	1080	1330
3/4"	Lower	2"	9"	12"	705	1330
7/8"	Upper	2"	10 1/2"	12"	1135	1330
7/8"	Lower	2"	10 1/2"	12"	705	1330

$$\frac{T_{actual}}{T_{allow}} + \frac{V_{actual}}{V_{allow}} \leq 1.2$$

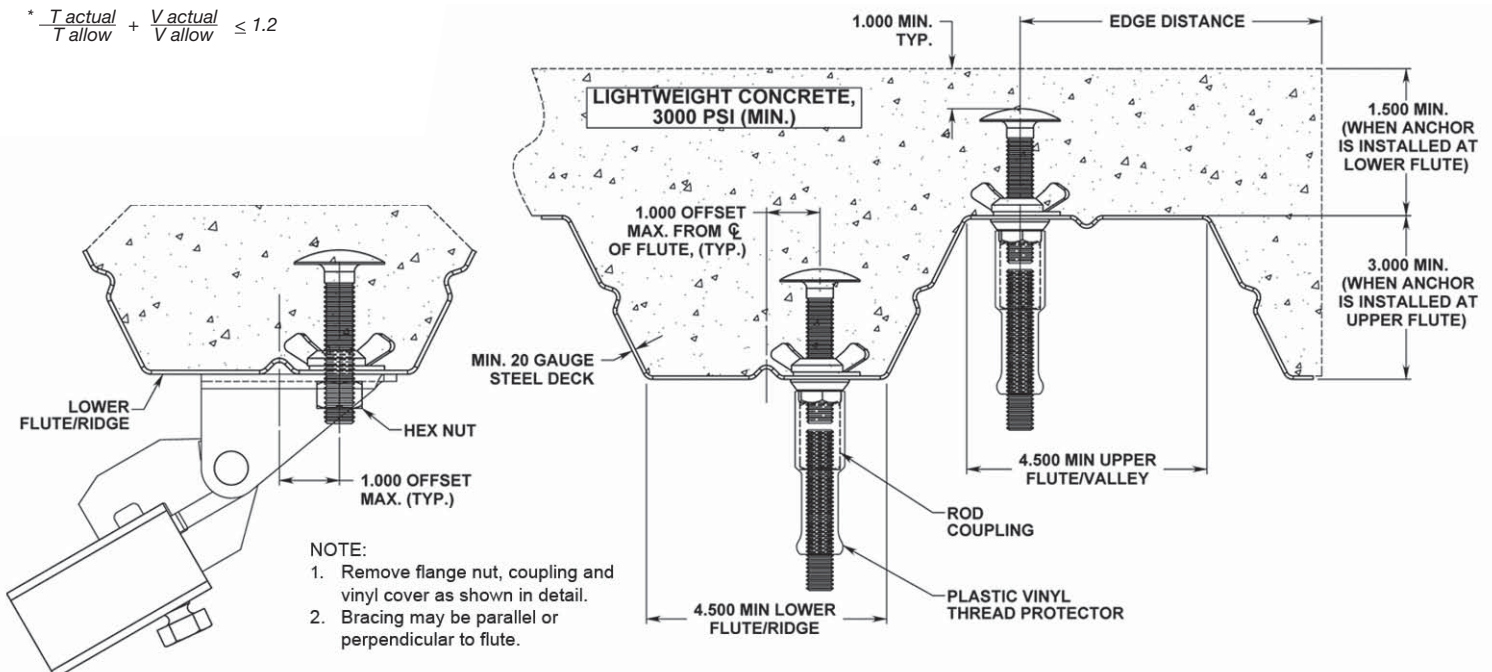
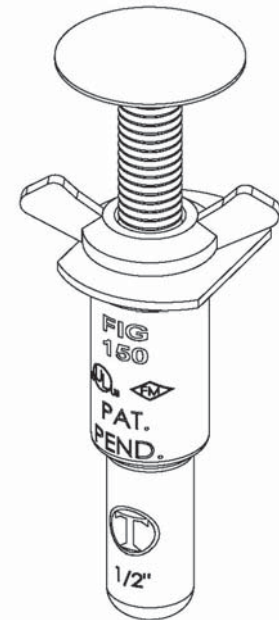


Fig. 200 - "Trimline" Adjustable Band Hanger

Size Range — 1/2" thru 8" pipe

Material — Carbon Steel, Mil. Galvanized to G90 specifications

Function — For fire sprinkler and other general piping purposes. Knurled swivel nut design permits hanger adjustment after installation.

Features —

- (1/2" thru 2") Flared edges ease installation for all pipe types and protect CPVC plastic pipe from abrasion. Captured design keeps adjusting nut from separating with hanger. Hanger is easily installed around pipe.
- (2 1/2" thru 8") Spring tension on nut holds it securely in hanger before installation. Adjusting nut is easily removed.

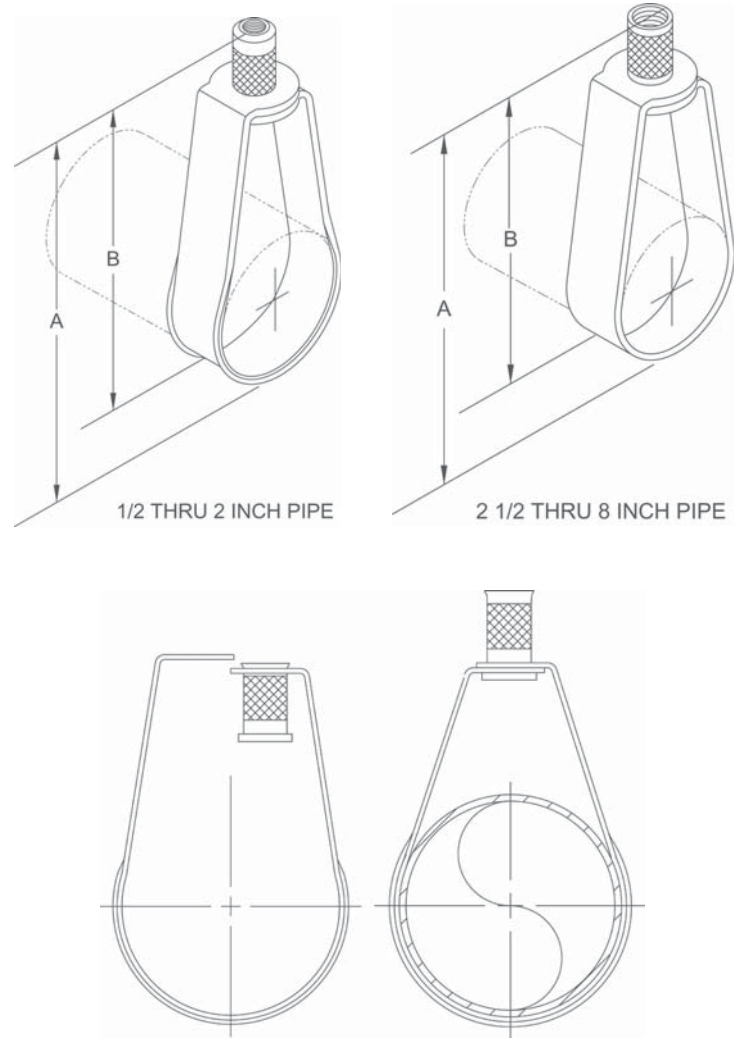
Approvals — Underwriters' Laboratories listed (1/2" thru 8") in the USA (**UL**) and Canada (**cUL**) for steel and CPVC plastic pipe and Factory Mutual Engineering Approved (3/4" thru 8"). Conforms to Federal Specifications WW-H-171E, Type 10 and Manufacturers Standardization Society SP-69, Type 10.

Maximum Temperature — 650°F

Finish — Mil. Galvanized. For Stainless Steel materials, order TOLCO® Fig. 200WON.

Order By — Figure number and pipe size

Note — For removable nut feature, order Fig. 200 S



Dimensions • Weights

Pipe Size	Rod Size Inch	Rod Size Metric	A	B	Max. Rec. Load Lbs.	Approx. Wt./100
1/2	3/8	8mm or 10mm	3 1/8	2 5/8	400	11
3/4	3/8	8mm or 10mm	3 1/8	2 1/2	400	11
1	3/8	8mm or 10mm	3 3/8	2 5/8	400	12
1 1/4	3/8	8mm or 10mm	3 3/4	2 7/8	400	13
1 1/2	3/8	8mm or 10mm	3 7/8	2 7/8	400	14
2	3/8	8mm or 10mm	4 1/2	3	400	15
2 1/2	3/8	10mm	5 5/8	4 1/8	600	27
3	3/8	10mm	5 7/8	4	600	29
3 1/2	3/8	10mm	7 3/8	5 1/4	600	34
4	3/8	10mm	7 3/8	5	1000	35
5	1/2	12mm	9 1/8	6 1/4	1250	66
6	1/2	12mm	10 1/8	6 3/4	1250	73
8	1/2	12mm	13 1/8	8 3/4	1250	136

Fig. 200H - Heavy Duty Band Hanger (for Trapeze)



Size Range — 2" thru 4" trapeze pipe size.
 Used to support up to 8" pipe. For 6" and 8" trapeze pipe, consult factory.

Material — Carbon Steel — Pre-Galvanized to G40 Spec

Function — Designed primarily to support substantially heavier loads than is normally intended for the nominal hanger size. Used extensively to support trapeze installations and the increased loads from **both** above and below the trapeze assembly.

Features — Furnished with 3/8" or 1/2" adjusting threaded ring nut.

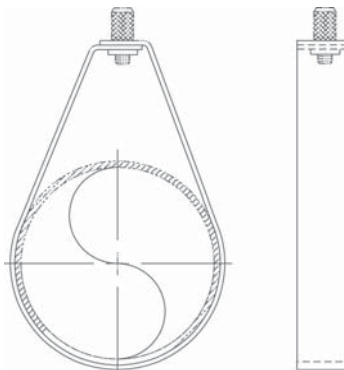
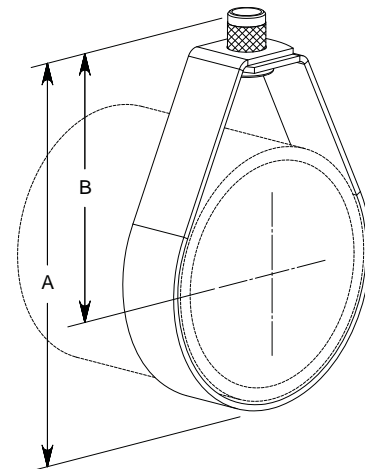
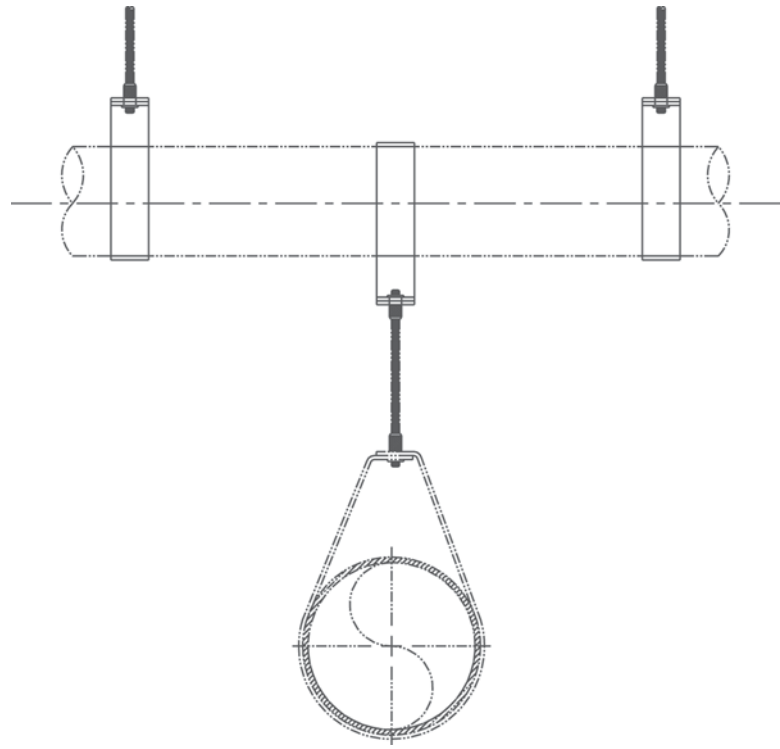
Approvals — Underwriters' Laboratories listed in the USA (**UL**) and Canada (**cUL**). Conforms to Federal Specification WW-H-171E, Type 10 and Manufacturers Standardization Society SP-69, Type 10.

Maximum Temperature — 650°F

Finish — Pre-Galvanized

Order By — Figure number, pipe size and rod size.

Important Design Note — Because of the increased loads applied to the trapeze assembly, **both** the upper trapeze supports as well as the lower hanging unit must be able to hold the maximum loads intended.



Dimensions • Weights				
Trapeze Pipe Size	Rod Size	A	B	Max. Rec. Load Lbs.
2	3/8	4 ⁹ / ₁₆	3 ⁷ / ₃₂	1250
2	1/2	4 ²⁹ / ₃₂	3 ³ / ₈	1250
2½	3/8	5 ⁵ / ₁₆	3 ²³ / ₃₂	1250
2½	1/2	5 ¹⁵ / ₃₂	3 ⁷ / ₈	1250
3	3/8	5 ³ / ₄	3 ²⁷ / ₃₂	1250
3	1/2	5 ⁷ / ₈	3 ³¹ / ₃₂	1250
4	3/8	6 ⁷ / ₈	4 ⁷ / ₁₆	1250
4	1/2	7 ¹ / ₃₂	4 ¹⁹ / ₃₂	1250

* Select trapeze pipe size based on section modulus required for span of trapeze per information provided in NFPA 13 (2002) Table 9.1.1.6.1 (a and b).

** All sizes are UL Listed to support up to 8" pipe at max spacing per NFPA 13.

Fig. 200WON - "Trimline" Adjustable Band Hanger w/o Swivel Nut

Size Range — 1/2" thru 8" pipe

Material — Carbon Steel

Function — Recommended for the suspension of fire sprinkler and non-insulated pipe or insulated pipe with Fig. 220 shield. Generally installed with two hex nuts.

Features — Flared edges on sizes 1/2" thru 2". Eases installation and protects CPVC pipe from any abrasion.

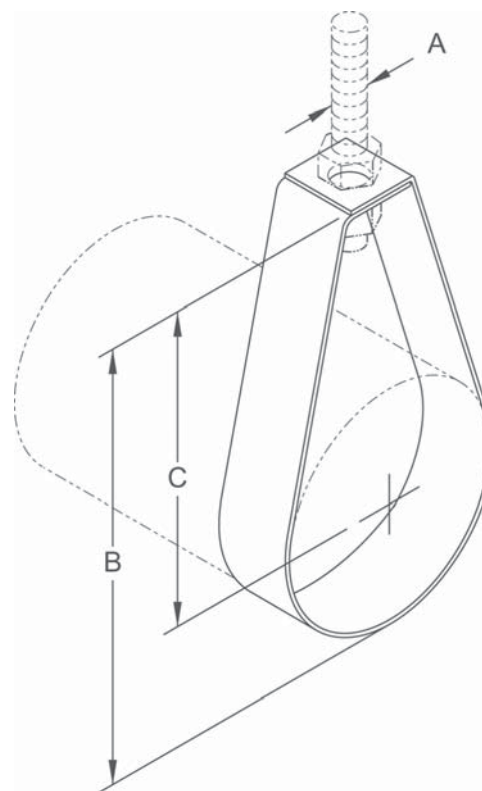
Approvals — Underwriters' Laboratories listed (1/2" thru 8") in the USA (**UL**) and Canada (**cUL**) for steel and CPVC plastic pipe. Conforms to Federal Specifications WW-171E, Type 7 and Manufacturers Standardization Society SP-69, Type 7

Maximum Temperature — 650°F

Finish — Mil. Galvanized to G-90

Note — Available in Stainless Steel materials

Order By — Figure number and pipe size



Dimensions • Weights

Pipe Size	Rod Size A	B	C	Max. Rec. Load Lbs.	Approx. Wt./100
1/2	3/8	2½	2	400	8
3/4	3/8	2½	2	400	8
1	3/8	2⅞	2⅞	400	9
1¼	3/8	3⅞	2½	400	10
1½	3/8	3½	2½	400	11
2	3/8	3¾	2½	400	12
2½	3/8	5⅞	3⅞	600	24
3	3/8	5⅞	3½	600	27
3½	3/8	6¾	4⅞	600	32
4	3/8	6¾	4½	1000	33
5	1/2	8⅞	5½	1250	60
6	1/2	9⅞	6	1250	68
8	1/2	12⅞	8	1250	130

Fig. 800 - Adjustable Sway Brace Attachment to Steel

Size Range — 4" thru 18" beam width

Material — Carbon Steel

Function — Seismic brace attachment to steel.

Features — This product's design incorporates a concentric attachment point which is critical to the performance of structural seismic connections. NFPA 13 indicates the importance of **concentric** loading of connections and fasteners. Permits secure connection to steel where drilling and/or welding of brace connection could present structural issues.

Installation Instructions — The Fig. 800 is the structural attachment component of a longitudinal or lateral sway brace assembly. It is intended to be combined with a TOLCO transitional attachment, "bracing pipe" and a TOLCO "braced pipe" attachment to form a complete bracing assembly. NFPA 13 and/or OSHPD guidelines should be followed.

To Install — Place the Fig. 800 on the steel beam, tighten the cone point set bolts on flange until bolt heads break off. Tighten hex head bolts into clamp body until lock washers are fully flat. Attach other TOLCO transitional attachment fittings, Fig. 909, 910 or 980. Transitional fitting attachment can pivot for adjustment to proper brace angle.

Approvals — Underwriters Laboratories Listed in the USA (**UL**) and Canada (**cUL**). Approved by Factory Mutual Engineering (**FM**). Included in our Seismic Restraints Catalog approved by the State of California Office of Statewide Health Planning and Development (**OSHPD**). For additional load, spacing and placement information relating to OSHPD projects, please refer to the TOLCO Seismic Restraint Systems Guidelines.

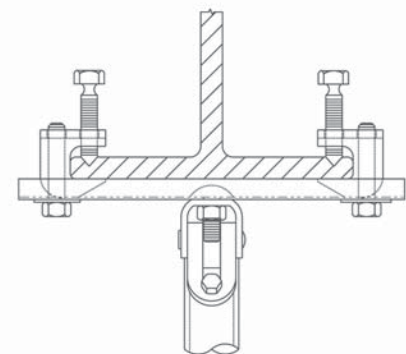
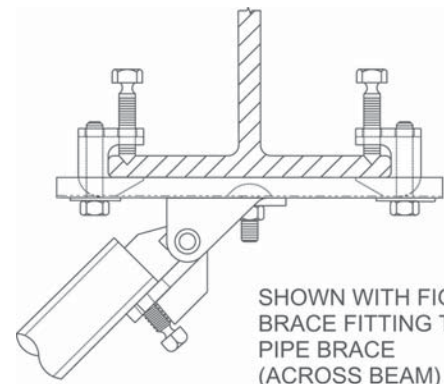
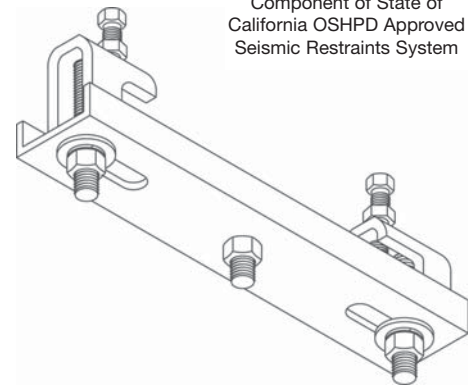
Finish — Plain

Note — Available in Electro-Galvanized and HDG finish.

Order By — Figure number, type number and size number.



Component of State of California OSHPD Approved Seismic Restraints System



Dimensions • Weights

Size	Fits Beam Range (In.)	Max. Design Loads/Lbs. (cULus)		*Max. Design Loads/Lbs. (FM)	
		Along Beam	Across Beam	Along Beam	Across Beam
1	4 - 6	1265	2015	2800	2800
2	6 - 8	1265	2015	2800	2800
3	8 - 10	1265	2015	2800	2800
4	10 - 12	1265	2015	2800	2800
5	12 - 14	1265	2015	2800	2800
6	14 - 16	1265	2015	2800	2800
7	16 - 18	1265	2015	2800	2800

Dimensions • Weights

Type	Flange Thickness Max. (In.)	Max. Design Loads/Lbs. (cULus)		*Max. Design Loads/Lbs. (FM)	
		Along Beam	Across Beam	Along Beam	Across Beam
1	3/4	1265	2015	2800	2800
2	1 1/4	1265	2015	2800	2800

* Load shown is allowable with brace installed, between 30° - 90°. No reduction of load based on brace angle is required.

TOLCO[®] brand bracing components are designed to be compatible **ONLY** with other TOLCO[®] brand bracing components, resulting in a Listed seismic bracing assembly. **DISCLAIMER** — NIBCO does **NOT** warrant against the failure of TOLCO[®] brand bracing components, in the instance that such TOLCO[®] brand bracing components are used in combination with products, parts or systems which are not manufactured or sold under the TOLCO[®] brand. NIBCO shall **NOT** be liable under any circumstance for any direct or indirect, incidental or consequential damages of any kind, including but not limited to loss of business or profit, where non-TOLCO brand bracing components have been, or are used.

Fig. 825 - Bar Joist Sway Brace Attachment

Size Range — One size accommodates all TOLCO Fig. 900 Series sway brace attachments. Maximum Horizontal Design Load 2015 lbs.

Material — Carbon Steel

Function — To attach sway bracing and hanger assemblies to steel open web structural members.

Features — This product's design incorporates a concentric attachment point which is critical to the performance of structural seismic connections. NFPA 13 indicates the importance of **concentric** loading of connections and fasteners. Permits secure non-friction connection without drilling or welding. Unique design reinforces point of connection to joist. Break off head bolt design assures verification of proper installation torque (min. 31 ft.-lbs.).

Approvals — Underwriters Laboratories Listed in the USA (**UL**) and Canada (**cUL**). Approved by Factory Mutual Engineering (**FM**). Included in our Seismic Restraints Catalog approved by the State of California Office of Statewide Health Planning and Development (**OSHPD**). For additional load, spacing and placement information relating to OSHPD projects, please refer to the TOLCO Seismic Restraint Systems Guidelines.

Installation Instructions — The Fig. 825 is the structural attachment component of a longitudinal or lateral sway brace assembly. It is intended to be combined with a TOLCO transitional attachment, "bracing pipe" and a TOLCO "braced pipe" attachment, to form a complete bracing assembly. NFPA 13 and/or OSHPD guidelines should be followed.

To Install — Place the Fig. 825 on the steel beam, tighten the cone point set bolts until bolt heads break off. Attach other TOLCO transitional attachment fitting, Fig. 909, 910 or 980. Transitional fitting attachment can pivot for adjustment to proper brace angle.

Important Structural Note:

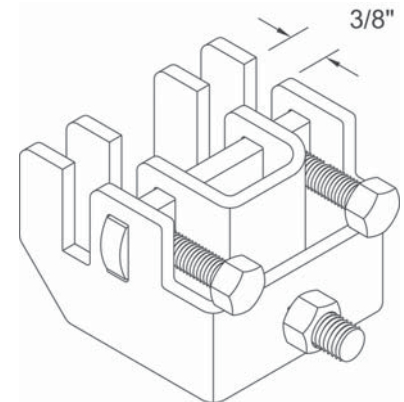
The TOLCO Fig. 825 has significant UL established design loads, however, structural issues related to the steel joist member require restricted location installation for all bracing. Steel Joist Manufacturers require that all earthquake bracing connections be within 6" of the cord panel point. Installation of the Fig. 825 must be limited to the outer third sections of the joist span. For installations within the center third section of the joist span, use **UL** Listed TOLCO Fig. 825A.

Finish — Plain, Electro-Galvanized and HDG

Order By — Figure number and finish
 US Patent #6,098,942, Canada Patent #2,286,659

* Load shown is allowable with brace installed, between 30° - 90°. No reduction of load based on brace angle is required.

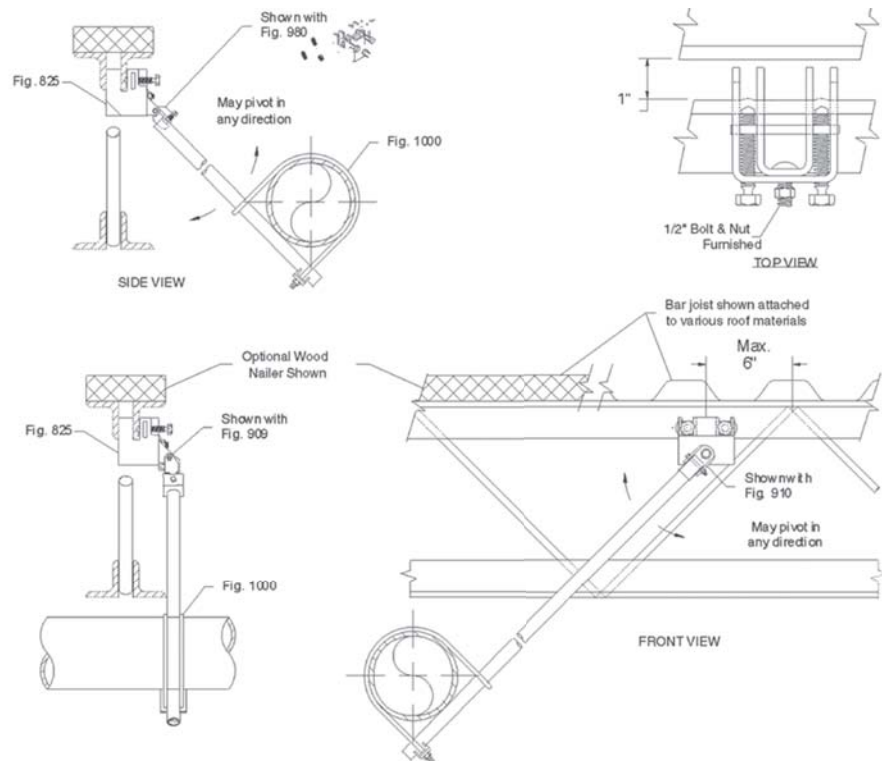
Component of State of California OSHPD Approved Seismic Restraints System



Maximum Design Load 2015 Lbs.
 Weight/100 237.5 Lbs.

UL Listed as Hanger Attachment
 6" Pipe Max.

FM Approved Design Loads*
 2900 - Across Beam
 1350 - Along Beam



TOLCO® brand bracing components are designed to be compatible **ONLY** with other TOLCO® brand bracing components, resulting in a Listed seismic bracing assembly. **DISCLAIMER** — NIBCO does **NOT** warrant against the failure of TOLCO® brand bracing components, in the instance that such TOLCO® brand bracing components are used in combination with products, parts or systems which are not manufactured or sold under the TOLCO® brand. NIBCO shall **NOT** be liable under any circumstance for any direct or indirect, incidental or consequential damages of any kind, including but not limited to loss of business or profit, where non-TOLCO brand bracing components have been, or are used.

Fig. 825A - Bar Joist Sway Brace Attachment



Size Range — One size accommodates all TOLCO Fig. 900 Series sway brace attachments. Maximum Horizontal Design Load 1265 lbs.

Material — Carbon Steel

Function — To attach sway bracing to steel open web structural members.

Features — This product's design incorporates a **concentric** attachment point which is critical to the performance of structural seismic connections. NFPA 13 indicates the importance of **concentric** loading of connections and fasteners. Permits secure non-friction connection without drilling or welding. Unique design reinforces point of connection to joist. Break off head bolt design assures verification of proper installation.

Approvals — Underwriter's Laboratories Listed in the USA (**UL**) and Canada (**cUL**). For additional load, spacing and placement information relating to OSHPD projects, please refer to the TOLCO Seismic Restraint Systems Guidelines.

Installation Instructions — The Fig. 825A is the structural attachment component of a longitudinal or lateral sway brace assembly. It is intended to be combined with a TOLCO transitional attachment, "bracing pipe" and a TOLCO "braced pipe" attachment to form a complete bracing assembly. NFPA 13 and/or OSHPD guidelines should be followed.

To Install — Place the Fig. 825A on the steel beam, tighten the cone point set bolts until bolt heads break off. Attach other TOLCO transitional attachment fitting, Fig. 909, 910 or 980. Transitional fitting attachment can pivot for adjustment to proper brace angle.

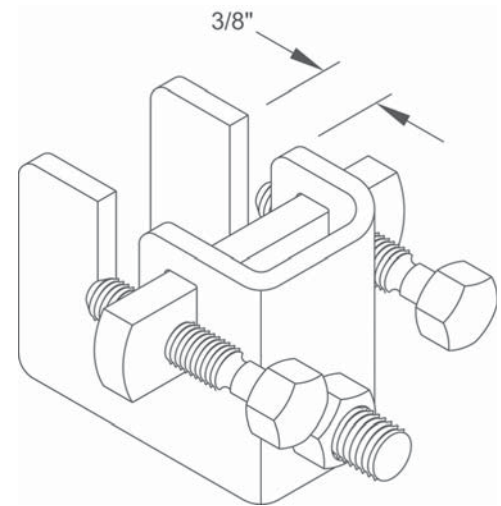
Important Structural Note:

The TOLCO Fig. 825A has significant UL established design loads, however, structural issues related to the steel joist member require restricted location installation for all bracing. Steel Joist Manufacturers require that all earthquake bracing connections be within 6" of the cord panel point. Installation of the Fig. 825A is not restricted to the two outer third sections of the joist. For greater design loads, refer to TOLCO Fig. 825.

Finish — Plain

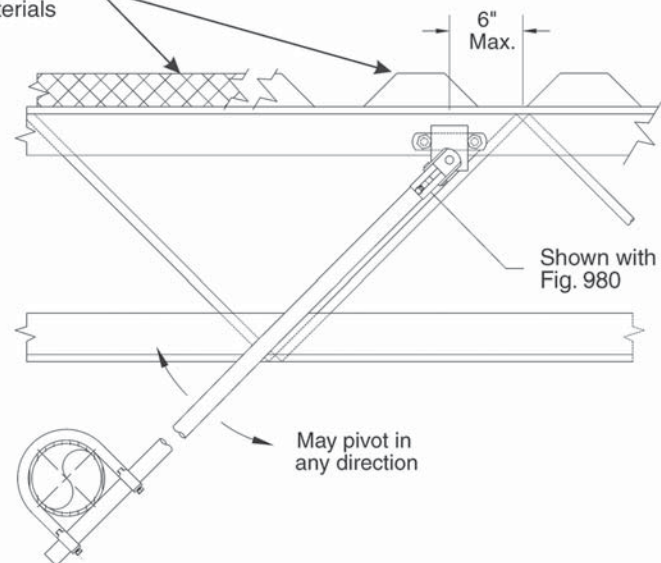
Order By — Figure number and finish

Patent #6,098,942



Maximum Design Load 1265 Lbs.

Bar joist shown attached to various roof materials



TOLCO® brand bracing components are designed to be compatible **ONLY** with other TOLCO® brand bracing components, resulting in a Listed seismic bracing assembly. **DISCLAIMER** — NIBCO does **NOT** warrant against the failure of TOLCO® brand bracing components, in the instance that such TOLCO® brand bracing components are used in combination with products, parts or systems which are not manufactured or sold under the TOLCO® brand. NIBCO shall **NOT** be liable under any circumstance for any direct or indirect, incidental or consequential damages of any kind, including but not limited to loss of business or profit, where non-TOLCO brand bracing components have been, or are used.

Fig. 906 - Sway Brace Multi-Fastener Adapter

Component of State of California OSHPD Approved Seismic Restraints System



Size Range — Use with 1" and 1¼" TOLCO UL listed Fig. 900 Series Earthquake Brace Attachments.

Material — Carbon Steel

Application — Allows sway brace fittings to develop greater load carrying ability by providing multiple fastener attachments. The National Fire Protection (NFPA) provides information on fastener loads to various structures. Refer to NFPA 13 (2002), Figure 9.3.5.9.1.

Approvals — Underwriters Laboratories Listed in the USA (UL) and Canada (cUL) only when used with TOLCO 900 Series Earthquake Brace Attachments. Included in our Seismic Restraints Catalog approved by the State of California Office of Statewide Health Planning and Development (OSHPD). For additional load, spacing and placement information relating to OSHPD projects, please refer to the TOLCO Seismic Restraint Systems Guidelines.

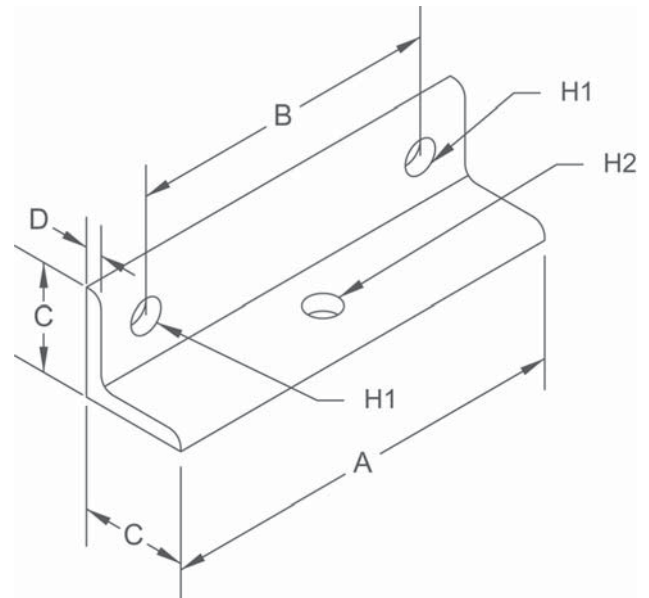
Installation Instructions — The Fig. 906 is a multiple fastener structural attachment component of a longitudinal or lateral sway brace assembly. It is intended to be combined with a TOLCO transitional attachment, "bracing pipe" and a TOLCO "braced pipe" attachment to form a complete bracing assembly. NFPA 13 and/or OSHPD guidelines should be followed.

To Install — Attach the Fig. 906 to the structural surface as per fastener design guidelines. Attach other TOLCO transitional attachment fitting Fig. 909, 910 or 980. Transitional fitting attachment can pivot for adjustment to proper brace angle.

Finish — Plain

Note — Available in Electro-Galvanized and HDG finish or Stainless Steel materials.

Order By — Figure number and specify dimensions H1 and H2.



Dimensions • Weights

A	B	C	D	H1	H2	Approx. Wt./100
12	9	2	1/4	Specify	Specify	Varies

TOLCO® brand bracing components are designed to be compatible **ONLY** with other TOLCO® brand bracing components, resulting in a Listed seismic bracing assembly. **DISCLAIMER** — NIBCO does **NOT** warrant against the failure of TOLCO® brand bracing components, in the instance that such TOLCO® brand bracing components are used in combination with products, parts or systems which are not manufactured or sold under the TOLCO® brand. NIBCO shall **NOT** be liable under any circumstance for any direct or indirect, incidental or consequential damages of any kind, including but not limited to loss of business or profit, where non-TOLCO brand bracing components have been, or are used.

Fig. 907 - 4-Way Longitudinal Sway Brace Attachment



Component of State of California OSHPD Approved Seismic Restraints System

Size Range — 1" x 1", 1" x 1¼" and 1¼" x 1¼" bracing pipe.

Material — Carbon Steel, hardened cone (or cup) point engaging screw

Function — For bracing pipe against sway and seismic disturbances, Functions as a longitudinal brace connection when attached to a lateral brace pipe. Bracing connection must be positioned as close as physically possible to the braced pipe (No more than 3" away). Must be used only with TOLCO bracing components. When used in conjunction with TOLCO Fig. 1000, this combination bracing restricts piping movement in tension and compression both laterally and longitudinally.

Approvals — Underwriter's Laboratories Listed in the USA (**UL**) and Canada (**cUL**). Included in our Seismic Restraints Catalog approved by the State of California Office of Statewide Health Planning and Development (**OSHPD**). For additional load, spacing and placement information relating to OSHPD projects, please refer to the TOLCO Seismic Restraint Systems Guidelines.

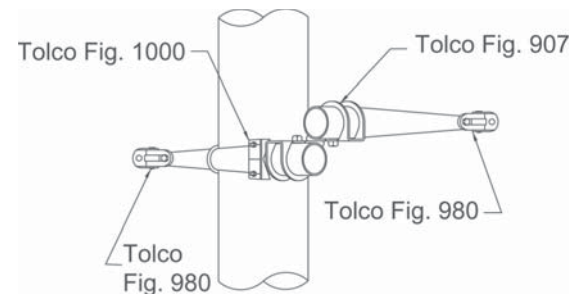
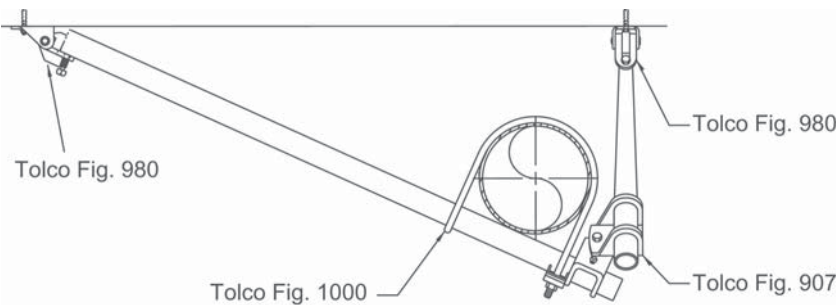
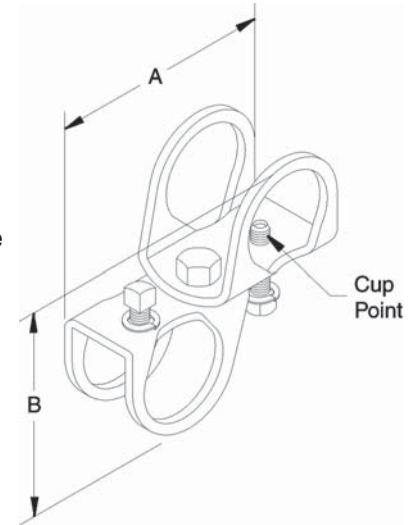
Installation Instructions — The Fig. 907 is a transitional component of a longitudinal 4-way sway brace assembly. It is intended to be installed with the longitudinal and lateral "bracing pipes", TOLCO structural attachment fittings, Fig. 909, 910 and 980 and the Fig. 1000 TOLCO "braced pipe" fitting, to form a complete bracing assembly. NFPA 13 and/or OSHPD guidelines should be followed.

To Install — Attach the Fig. 907 over the lateral "bracing pipe" to within 3" of its position relative to the "braced pipe" connection. Adjust brace angle and tighten bolts until heads bottom out on surface.

Finish — Plain

Note — Available in Electro-Galvanized and HDG finish.

Order By — Figure number, bracing pipe sizes and finish.



Dimensions • Weights				
Pipe Size	A	B	Max. Design Load Lbs.*	Approx. Wt./100
1 x 1	4¾	4¾	655*	103
1 x 1¼	5¼	4¼	655*	107
1¼ x 1¼	5¾	5¼	655*	109

* Load will accommodate up to 4" pipe at maximum spacing.

TOLCO® brand bracing components are designed to be compatible **ONLY** with other TOLCO® brand bracing components, resulting in a Listed seismic bracing assembly. **DISCLAIMER** — NIBCO does **NOT** warrant against the failure of TOLCO® brand bracing components, in the instance that such TOLCO® brand bracing components are used in combination with products, parts or systems which are not manufactured or sold under the TOLCO® brand. NIBCO shall **NOT** be liable under any circumstance for any direct or indirect, incidental or consequential damages of any kind, including but not limited to loss of business or profit, where non-TOLCO brand bracing components have been, or are used.

Fig. 909 - No-Thread Swivel Sway Brace Attachment



Size Range — 1" bracing pipe. For brace pipe sizes larger than 1", use TOLCO Fig. 980.

Material — Carbon Steel, hardened cone point engaging screw

Function — The structural component of a sway and seismic bracing system.

Features — This product's design incorporates a **concentric** attachment opening which is critical to the performance of structural seismic connections. NFPA 13 (2002) Figure 9.3.5.9.1 indicates clearly that fastener table load values are based only on concentric loading. No threading of the bracing pipe is required. Open design allows for easy inspection of pipe engagement.

Application Note — The Fig. 909 is used in conjunction with the TOLCO Fig. 1000, Fig. 1001, or Fig. 4 (A) pipe clamp, and joined together with bracing pipe. Sway brace assemblies are intended to be installed in accordance with NFPA 13 (or TOLCO State of California OSHPD Approved Seismic Restraint Manual) and the manufacturer's installation instructions. The required type, number and size of fasteners used for the structure attachment fitting shall be in accordance with NFPA 13 and/or OSHPD.

Approvals — Underwriters Laboratories Listed in the USA (**UL**) and Canada (**cUL**). Included in our Seismic Restraints Catalog approved by the State of California Office of Statewide Health Planning and Development (**OSHPD**). For additional load, spacing and placement information relating to OSHPD projects, please refer to the TOLCO Seismic Restraint Systems Guidelines.

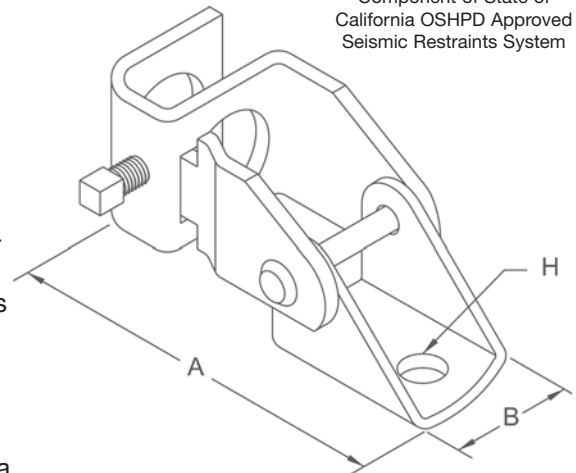
Installation Instructions — The Fig. 909 is the structural or transitional attachment component of a longitudinal or lateral sway brace assembly. It is intended to be combined with the "bracing pipe" and TOLCO "braced pipe" attachment, Fig. 1000, 1001, 4A, 4B or 4L to form a complete bracing assembly. NFPA 13 and/or OSHPD guidelines should be followed.

To Install — Place the Fig. 909 onto the bracing pipe. Tighten the set bolt until head bottoms out on surface. Attachment can pivot for adjustment to proper brace angle.

Finish — Plain

Note — Available in Electro-Galvanized and HDG finish.

Order By — Figure number, pipe size and finish.



Component of State of California OSHPD Approved Seismic Restraints System

Dimensions • Weights

Pipe Size	A	B	Hole Size H*	Max. Design Load Lbs.	Max. Design Load Lbs. w/Washer	Approx. Wt./100
1	6	1 5/8	17/32	2015	2765	91

* Available with hole sizes to accommodate up to 3/4" fastener. Consult Factory.

TOLCO® brand bracing components are designed to be compatible **ONLY** with other TOLCO® brand bracing components, resulting in a Listed seismic bracing assembly. **DISCLAIMER** — NIBCO does **NOT** warrant against the failure of TOLCO® brand bracing components, in the instance that such TOLCO® brand bracing components are used in combination with products, parts or systems which are not manufactured or sold under the TOLCO® brand. NIBCO shall **NOT** be liable under any circumstance for any direct or indirect, incidental or consequential damages of any kind, including but not limited to loss of business or profit, where non-TOLCO brand bracing components have been, or are used.

Fig. 910 - Swivel Sway Brace Fitting



Size Range — 1" and 1¼" bracing pipe. For brace pipe sizes larger than 1¼", use TOLCO Fig. 980.

Material — Carbon Steel

Function — For bracing pipe against sway and seismic disturbances. The building attachment component of a sway brace system; the Fig. 910 is used in conjunction with the Fig. 1001, Fig. 1000 or with a Fig. 4A Pipe Clamp and joined together with a brace pipe per NFPA 13.

Features — This product's design incorporates a **concentric** attachment opening which is critical to the performance of structural seismic connections. NFPA 13 (2002) Figure 9.3.5.9.1 indicates that fastener table load values are based only on concentric loading. Universal swivel design allows Fig. 910 to be attached at any surface angle.

Approvals — Underwriter's Laboratories Listed in the USA (**UL**) and Canada (**cUL**). Included in our Seismic Restraints Catalog approved by the State of California Office of Statewide Health Planning and Development (**OSHPD**). For additional load, spacing and placement information relating to OSHPD projects, please refer to the TOLCO Seismic Restraint Systems Guidelines.

Installation Instructions — The Fig. 910 is a structural or transitional attachment component of a longitudinal or lateral sway brace assembly. It is intended to be combined with the "bracing pipe", and TOLCO "braced pipe" attachment, Fig. 1000, 1001, 4A, 4B or 4L to form a complete bracing assembly. Follow NFPA 13 and/or OSHPD guidelines.

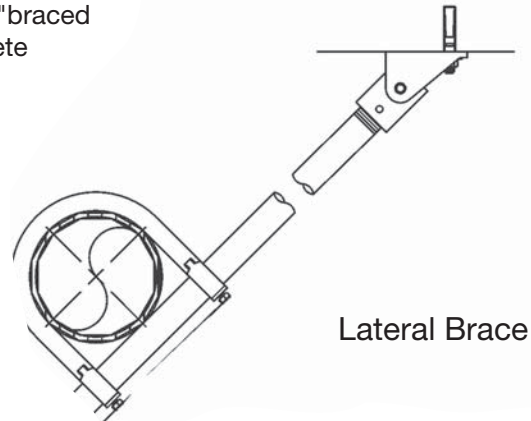
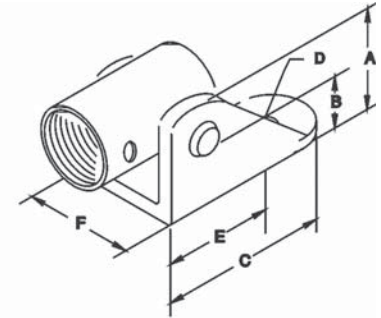
To Install — Thread the pipe into the Fig. 910 until pipe threads are visible through inspection site hole. Attachment can pivot for adjustment to proper brace angle.

Note — The Fig. 910 Swivel Attachment and the Fig. 1001, Fig. 1000, or Fig. 4A Pipe Clamp make up a sway brace system of (**UL**) Listed attachments and bracing materials which satisfies the requirements of Underwriters' Laboratories and the National Fire Protection Association (**NFPA**).

Finish — Plain

Note — Available in Electro-Galvanized and HDG finish.

Order By — Figure number, pipe size and finish.



Dimensions • Weights								
Pipe Size	A	B	C	Hole Size D	E	F	Max. Design Load Lbs.	Approx. Wt./100
1	2	1½	3	9/16	2 ⁵ / ₁₆	2	2015	88
1¼	1 ³ / ₁₆	1 ⁵ / ₁₆	3	9/16	2 ⁵ / ₁₆	2 ⁵ / ₁₆	2015	99

NOTE - Available with hole sizes to accommodate up to 3/4" fastener. Consult factory.

TOLCO® brand bracing components are designed to be compatible **ONLY** with other TOLCO® brand bracing components, resulting in a Listed seismic bracing assembly. **DISCLAIMER** — NIBCO does **NOT** warrant against the failure of TOLCO® brand bracing components, in the instance that such TOLCO® brand bracing components are used in combination with products, parts or systems which are not manufactured or sold under the TOLCO® brand. NIBCO shall **NOT** be liable under any circumstance for any direct or indirect, incidental or consequential damages of any kind, including but not limited to loss of business or profit, where non-TOLCO brand bracing components have been, or are used.

Fig. 975 - Straight Sway Brace Fitting



Size Range — 1" bracing pipe. For brace pipe sizes larger than 1", use TOLCO Fig. 980.

Material — Carbon Steel

Function — For bracing pipe against sway and seismic disturbances. The building attachment component of a sway brace system; the Fig. 975 is used in conjunction with the Fig. 1000, Fig. 1001 or with a Fig. 4A Pipe Clamp and joined together with a brace pipe per NFPA 13.

Features — Open design allows for easy checking of thread engagement.

Approvals — Underwriters Laboratories Listed in the USA (**UL**) and Canada (**cUL**).

Installation — The Fig. 975 is the structural or transitional attachment component of a longitudinal or lateral sway brace assembly. It is intended to be combined with the "bracing pipe" and TOLCO "braced pipe" attachment, Fig. 1000, 1001, 4A, 4B or 4L to form a complete bracing assembly. NFPA 13 and/or OSHPD guidelines should be followed.

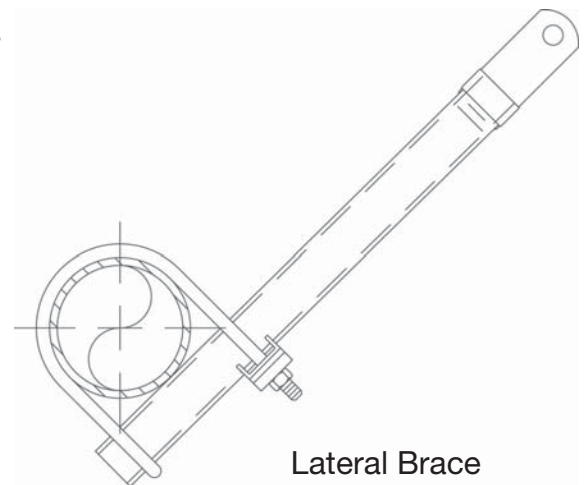
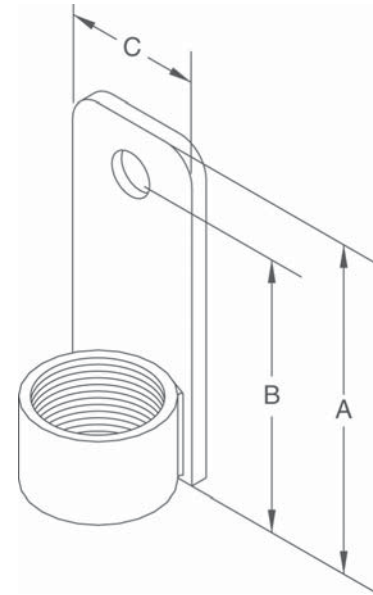
To Install — Thread the Fig. 975 onto the threaded bracing pipe. Attachment can pivot for adjustment to proper brace angle. (Bending of plate not permitted.)

Finish — Plain

Note — Available in Electro-Galvanized and HDG finish or Stainless Steel materials.

Order By — Figure number and finish.

Note — Bending of this fitting alters the material strength. Use Fig. 909 or Fig. 910 when angle fitting is required.



Dimensions • Weights						
Pipe Size	A	B	C	Hole Size	Max. Design Load Lbs.	Approx. Wt./100
1	4	3½	1½	9/16	2015	88

NOTE - Available with hole sizes to accommodate up to 3/4" fastener. Consult factory.

TOLCO® brand bracing components are designed to be compatible **ONLY** with other TOLCO® brand bracing components, resulting in a Listed seismic bracing assembly. **DISCLAIMER** — NIBCO does **NOT** warrant against the failure of TOLCO® brand bracing components, in the instance that such TOLCO® brand bracing components are used in combination with products, parts or systems which are not manufactured or sold under the TOLCO® brand. NIBCO shall **NOT** be liable under any circumstance for any direct or indirect, incidental or consequential damages of any kind, including but not limited to loss of business or profit, where non-TOLCO brand bracing components have been, or are used.

Fig. 980 - Universal Swivel Sway Brace Attachment

Size Range — One size fits bracing pipe 1" thru 2", TOLCO 12 gauge channel, and all structural steel up to 1/4" thick.

Material — Carbon Steel

Function — Multi-functional attachment to structure or braced pipe fitting.

Features — This product's design incorporates a **concentric** attachment opening which is critical to the performance of structural seismic connections. NFPA 13 (2002) Figure 9.3.5.9.1 indicates clearly that fastener table load values are based only on concentric loading. Mounts to any surface angle. Break off bolt head assures verification of proper installation.

Installation — The Fig.980 is the structural or transitional attachment component of a longitudinal or lateral sway brace assembly. It is intended to be combined with the "bracing pipe" and TOLCO "braced pipe" attachment, Fig. 1000, 1001, 2002, 4L, 4A or 4B to form a complete bracing assembly. NFPA 13 and/or OSHPD guidelines should be followed.

To Install — Place the Fig. 980 onto the "bracing pipe". Tighten the set bolt until set bolt head breaks off. Attachment can pivot for adjustment to proper brace angle.

Approvals — Underwriters Laboratories Listed in the USA (**UL**) and Canada (**cUL**). Approved by Factory Mutual Engineering (**FM**). Included in our Seismic Restraints Catalog approved by the State of California Office of Statewide Health Planning and Development (**OSHPD**). For additional load, spacing and placement information relating to OSHPD projects, please refer to the TOLCO Seismic Restraint Systems Guidelines.

Note — The Fig. 980 Swivel Attachment and the Fig. 1001, Fig. 1000, Fig. 2001 or Fig. 4A Pipe Clamp make up a sway brace system of **UL** Listed attachments and bracing materials which satisfies the requirements of Underwriters' Laboratories and the National Fire Protection Association (**NFPA**)

Finish — Plain

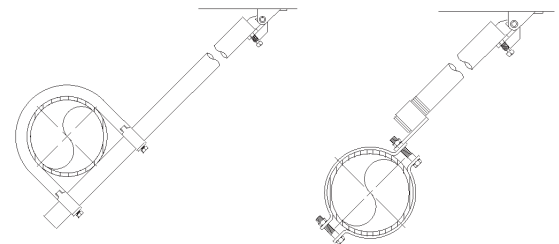
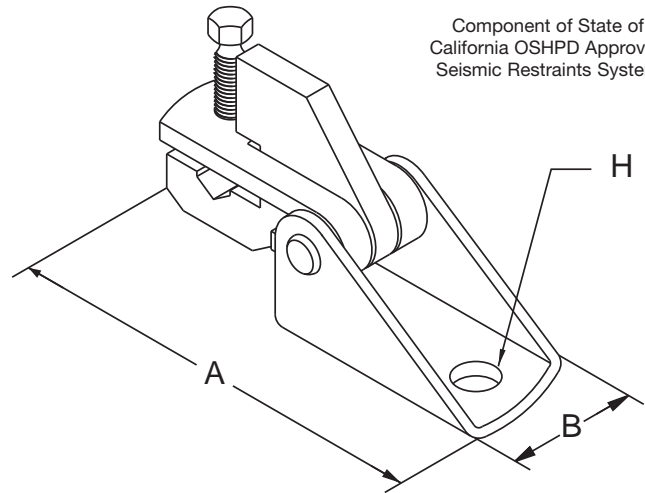
Note — Available in Electro-Galvanized finish.

Order By — Figure number and finish.

PATENT #6,273,372



Component of State of California OSHPD Approved Seismic Restraints System



Lateral Brace

Dimensions • Weights

A	B	H*	Max. Design Load Lbs. (cULus)	**Max. Design Load Lbs. (FM)	Approx. Wt./100
5¼	1⅞	17/32	2765	2800	132

* Available with hole sizes to accommodate up to 3/4" fastener. Consult factory.

** Load shown is allowable with brace installed, between 30° - 90°. No reduction of load based on brace angle is required.

TOLCO[®] brand bracing components are designed to be compatible **ONLY** with other TOLCO[®] brand bracing components, resulting in a Listed seismic bracing assembly. **DISCLAIMER** — NIBCO does **NOT** warrant against the failure of TOLCO[®] brand bracing components, in the instance that such TOLCO[®] brand bracing components are used in combination with products, parts or systems which are not manufactured or sold under the TOLCO[®] brand. NIBCO shall **NOT** be liable under any circumstance for any direct or indirect, incidental or consequential damages of any kind, including but not limited to loss of business or profit, where non-TOLCO brand bracing components have been, or are used.

Fig. 981 - Fast Attach — Universal Swivel Sway Brace Attachment

Size Range — One size fits bracing pipe 1" thru 2", TOLCO 12 gauge channel, and all structural steel up to 1/4" thick.

Material — Carbon Steel

Function — Multi-functional attachment to hanger rod, trapeze rod, structure or braced pipe fitting.

Features — Fits multiple sizes of bracing pipe, strut or structural steel. Swivel allows adjustment to various surface angles. Break-away bolt head assures verification of proper installation torque. Unique "fast attach" yoke design allows Fig. 981 to be installed using hanger rods 3/8" through 3/4" in size. "Stackable" design allows installation of both lateral and longitudinal braces, as well as opposing braces, to be easily installed on a single hanger rod, with no disassembly. The retrofit yoke has a visual verification of proper installation torque. Tighten existing hex nut down until the slight gap in the yoke assembly closes completely.

Installation — The Fig. 981 is the "braced pipe" attachment component of a lateral or longitudinal brace assembly. It is intended to be combined with the pipe hanger, all-thread rod, "bracing pipe" and TOLCO transitional and structural attachment component(s) to form a complete bracing assembly. NFPA 13 and or OSHPD guidelines should be followed.

To Install — Spin nut on top of hanger counterclockwise to loosen the nut and raise it above the top of the hanger. Attach Fig. 981 by slipping the open side of the 981 yoke onto the all thread rod above the top of the hanger. Be sure that the concave indented side of the Fig. 981 yoke is facing upward away from the top of the hanger toward the loosened hex net. Spin the hex nut clockwise and tighten securely. Insert brace pipe into the jaw of the 981 and tighten the cone point set bolt until the hex head breaks off ensuring proper installation torque. Pivot brace pipe to proper angle and attach to structure using a TOLCO swivel structural attachment


Approvals — Underwriter's Laboratories Listed in the USA (UL) and Canada (cUL) for steel and CPVC pipe. Included in our Seismic Restraint Systems Guidelines, approved by the California Office of Statewide Health Planning and Development (**OSHPD**). For additional load, spacing and placement information relating to OSHPD projects, please refer to the TOLCO Seismic Restraint Systems Guidelines.

Finish — Electro-Galvanized

Order By — Figure number, rod size 3/8" thru 3/4" and finish.

Pat. # 6,273,372, Pat. # 7,097,141

Dimensions • Weights					
A	B	C	D	Max. Design Load Lbs.	Approx. Wt./100
5 1/8	4 1/8	1 1/4	2 1/4	2015	88

Component of State of California OSHPD Approved Seismic Restraints System 

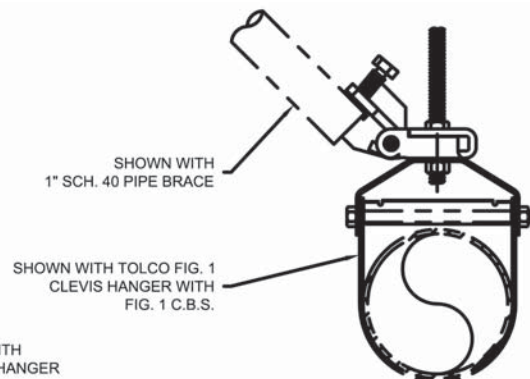
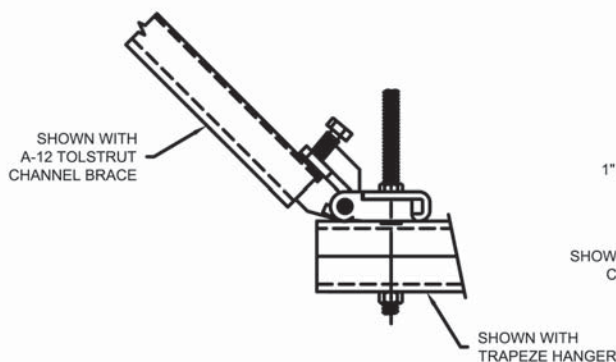
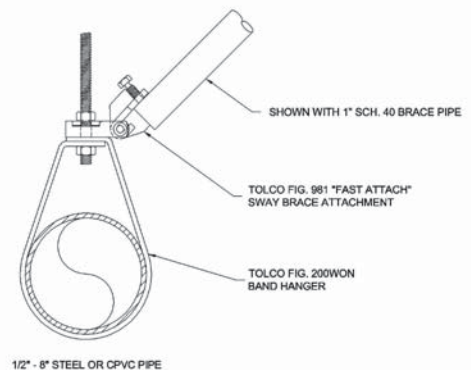
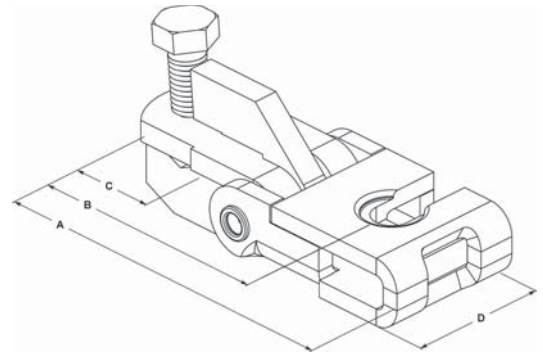


Fig. 990 - Cable Sway Brace Attachment

Size Range — 1/8", 3/16" and 1/4" pre-stretched cable. 3/8" thru 1 1/4" hanger rod bolt or fastener.

Material — Carbon Steel

Function — Cable attachment for sway bracing. Attaches sway brace to structure or to hanger. To be used with 7 x 19 strand core pre-stretched galvanized aircraft cable.

Features — Cable easily slides into oversized front arch opening. Breakaway hex nuts assure verification of proper installation. Will mount to any surface angle.

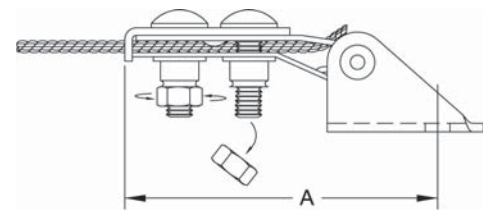
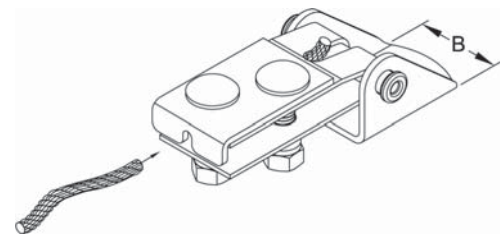
Approvals — Included in our Seismic Restraints Catalog approved by the State of California Office of Statewide Health Planning and Development (OSHPD). For additional load, spacing and placement information relating to OSHPD projects, please refer to the TOLCO Seismic Restraint System Guidelines.

Finish — Electro-Galvanized

Order By — Figure number, cable size and mounting hole size.

Note — Order 990H for hanger rod, bolt or fastener hole size 1" thru 1 1/4".

Component of State of California OSHPD Approved Seismic Restraints System



(Cable Must Be Through Entire Slot Opening)

Dimensions • Weights

Cable Diameter	A	B	Maximum Design Load Lbs.
1/8"	4 ⁵ / ₁₆	2	975*
3/16"	5	2 ¹ / ₄	2050*
1/4"	5	2 ⁵ / ₈	3150*

* Maximum load rating controlled by cable breaking strength.

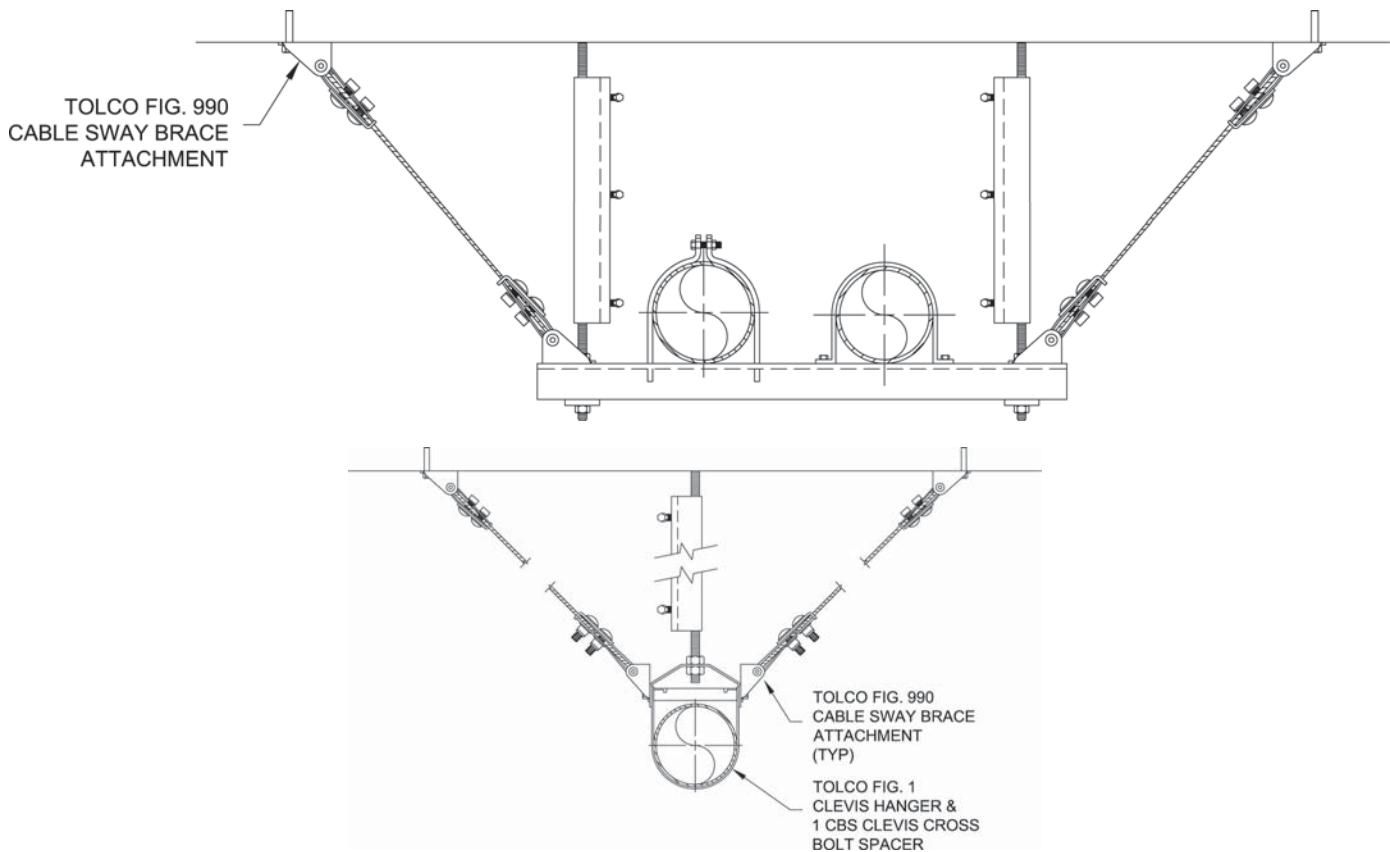


Fig. 991 - Fast Attach — Cable Sway Brace Attachment

Size Range — 1/8", 3/16" and 1/4" pre-stretched cable. Fits rod size 3/8" thru 3/4".

Material — Carbon Steel

Function — Cable attachment for sway bracing. Attaches sway brace to hanger rod. To be used with 7 x 19 strand core pre-stretched galvanized aircraft cable.

Features — Fits multiple sizes of cable. Cable easily slides into oversized front arch opening. Swivel allows adjustment to various surface angles. Break-away hex nuts assure verification of proper installation torque. Unique "Fast-Attach" yoke design allows Fig. 991 to be installed using hanger rods 3/8" through 3/4" in size. "Stackable" design allows installation of both lateral and longitudinal braces, as well as opposing braces, to be easily installed on a single hanger rod, with no disassembly. The retrofit yoke has a visual verification of proper installation torque. Tighten existing hex nut down until the slight gap in the yoke assembly closes completely.

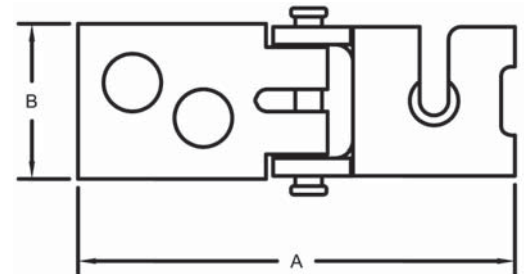
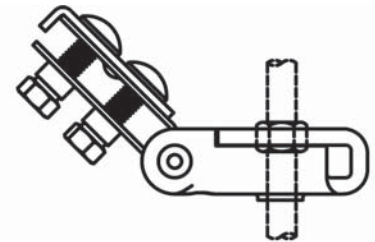
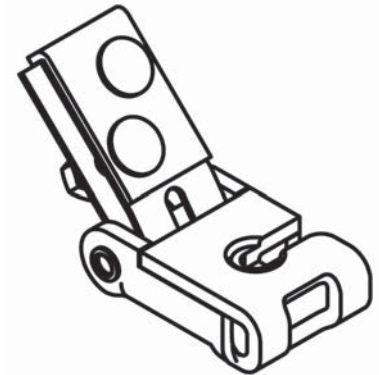
Approvals — Included in our Seismic Restraints Catalog approved by the State of California Office of Statewide Health Planning and Development (**OSHPD**). For additional load, spacing and placement information relating to OSHPD projects, please refer to the TOLCO Seismic Restraint System Guidelines.

Finish — Electro-Galvanized

Order By — Figure number, rod size 3/8" through 3/4"

Pat. # 7,097,141

Component of State of California OSHPD Approved Seismic Restraints System



Dimensions • Weights			
Cable Diameter	A	B	Maximum Design Load Lbs.
1/8	5¾	2⅛	975*
3/16	6¾	2½	2050*
1/4	6¾	2½	3150*

* Maximum load rating controlled by cable breaking strength.

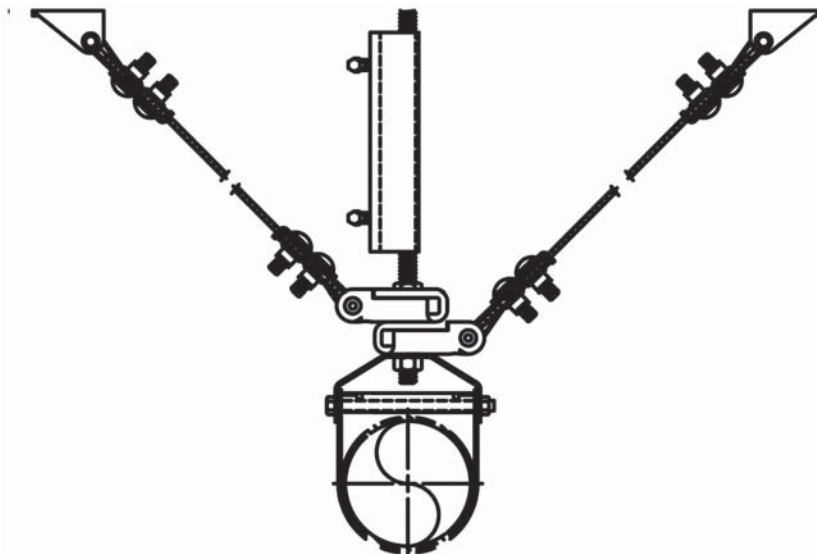


Fig. 1000 - "Fast Clamp" Sway Brace Attachment

Component of State of California OSHPD Approved Seismic Restraints System

Size Range — Pipe size to be braced: 1" thru 6" Schedule 10 thru 40 IPS.* Pipe size used for bracing: 1" and 1¼" Schedule 40 IPS.

* Additionally (UL) approved for use to brace Schedule 7 sprinkler pipe up to 4" (maximum horizontal design load 655 lbs.) Torque requirement 6 — 8 ft. lbs.

Material — Carbon Steel

Function — For bracing pipe against sway and seismic disturbance. The pipe attachment component of a sway brace system: Fig. 1000 is used in conjunction with a TOLCO Fig. 900 Series Fitting and joined together with bracing pipe per NFPA 13* or TOLCO OSHPD Approved Seismic Manual, forming a complete sway brace assembly.

Features — Field adjustable, making critical pre-engineering of bracing pipe unnecessary. Unique design requires no threading of bracing pipe. Can be used as a component of a 4-way riser brace. Can be used as longitudinal brace with Fig. 907. Comes assembled and individually packaged with illustrated installation instructions — sizes are clearly marked. Steel leaf spring insert provided to assure installer and inspector necessary minimum torque has been achieved.

Installation — The Fig. 1000 is the "braced pipe" attachment component of a lateral sway brace assembly. It is intended to be combined with the "bracing pipe" and TOLCO structural attachment component, Fig. 980, 910 or 909 to form a complete bracing assembly. Follow NFPA 13 and/or OSHPD guidelines.

To Install — Place the Fig. 1000 over the pipe to be braced, insert bracing pipe through opening leaving a minimum of 1" extension. Brace pipe can be installed on top or bottom of pipe to be braced. Tighten hex nuts until leaf spring is flat. It is recommended that the brace angle be adjusted before hex nuts are fully tightened.

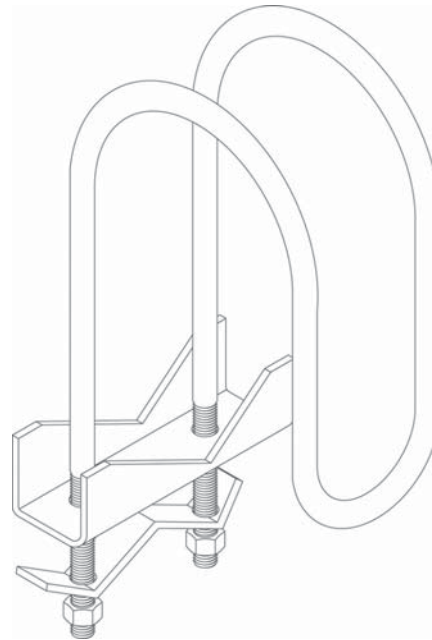
Approvals — Underwriters Laboratories Listed in the USA (UL) and Canada (cUL). Approved by Factory Mutual Engineering (FM). Included in our Seismic Restraints Catalog approved by the State of California Office of Statewide Health Planning and Development (OSHPD). For additional load, spacing and placement information relating to OSHPD projects, please refer to the TOLCO Seismic Restraint Systems Guidelines.

Application Note — Position Fast Clamp and tighten two hex nuts until leaf spring flattens. A minimum of 1" pipe extension beyond the Fig. 1000 is recommended.

Finish — Plain

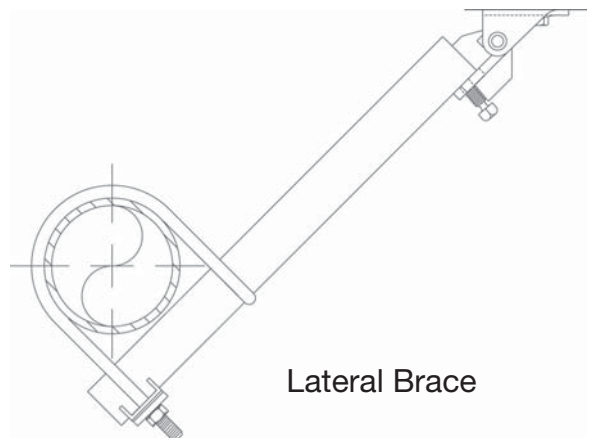
Note — Available in Electro-Galvanized and HDG finish or Stainless Steel materials.

Order By — Order first by pipe size to be braced, followed by pipe size used for bracing, figure number and finish.



Maximum Design Load
 1" thru 4" pipe size — 2015 lbs.
 6" size — 1265 lbs.

FM Approved Design Loads*
 1" - 2½" - 600 lbs.
 3" - 4" - 700 lbs.



Lateral Brace

TOLCO® brand bracing components are designed to be compatible **ONLY** with other TOLCO® brand bracing components, resulting in a Listed seismic bracing assembly. **DISCLAIMER** — NIBCO does **NOT** warrant against the failure of TOLCO® brand bracing components, in the instance that such TOLCO® brand bracing components are used in combination with products, parts or systems which are not manufactured or sold under the TOLCO® brand. NIBCO shall **NOT** be liable under any circumstance for any direct or indirect, incidental or consequential damages of any kind, including but not limited to loss of business or profit, where non-TOLCO brand bracing components have been, or are used.

Fig. 1001 - Sway Brace Attachment

Size Range — Pipe size to be braced: 2½" thru 8" IPS.* Pipe size used for bracing: 1" and 1¼" Schedule 40 IPS.

Material — Carbon Steel

Function — For bracing pipe against sway and seismic disturbance. The pipe attachment component of a sway brace system: The Fig. 1001 is used in conjunction with a TOLCO 900 Series fitting and joined together with bracing pipe per NFPA 13, forming a complete sway brace assembly.

Features — Can be used to brace schedules 7 through 40 IPS. Field adjustable, making critical pre-engineering of bracing pipe length unnecessary. Unique design requires no threading of bracing pipe. Can be used as a component of a four-way riser brace. Comes assembled and ready for installation. Fig. 1001 has built-in visual verification of correct installation. See installation note below.

Installation Note — Position Fig. 1001 over the pipe to be braced and tighten two hex head cone point set bolts until heads bottom out. A minimum of 1" pipe extension is recommended. Brace pipe can be installed on top or bottom of pipe to be braced.

Approvals — Underwriters Laboratories Listed in the USA (**UL**) and Canada (**cUL**). Approved by Factory Mutual Engineering (**FM**). Included in our Seismic Restraints Catalog approved by the State of California Office of Statewide Health Planning and Development (**OSHPD**). For additional load, spacing and placement information relating to OSHPD projects, please refer to the TOLCO Seismic Restraint Systems Guidelines.

Finish — Plain

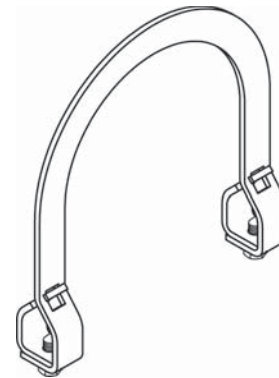
Note — Available in Electro-Galvanized and HDG finish.

Order By — Indicate pipe size to be braced followed by pipe size used for bracing, figure number and finish.

Important Note — The Fig. 1001 is precision manufactured to perform its function as a critical component of a complete bracing assembly. **To ensure performance, the UL Listing requires that the Fig. 1001 must be used only with other TOLCO bracing products. The Fig 1001 is not intended for use with the Fig. 907 4-Way Longitudinal Brace Attachment.**

US AND INTERNATIONAL PATENT APPLICATION IN PROCESS

Component of State of California OSHPD Approved Seismic Restraints System



Maximum Design Load Sch. 7 - 1600 lbs. Sch. 10 & 40 w/1" Brace Pipe - 2015 lbs. Sch. 10 & 40 w/1¼" Brace Pipe - 2765 lbs.
--

FM Approved Design Loads* 2½" - 2400 lbs. 3" - 4" - 2500 lbs. 5" - 8" - 1500 lbs.
--

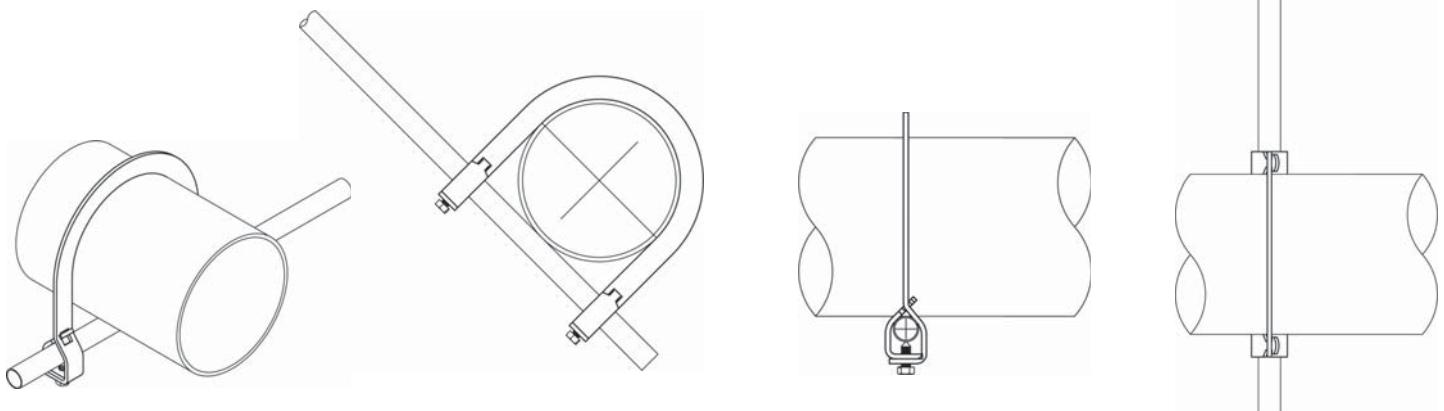


Fig. 2002 - Sway Brace Attachment

Size Range — Pipe size to be braced: 2½" thru 8" all steel schedules, copper, plastic, FRP, cast iron and ductile iron. Consult factory when bracing other than steel. The Fig. 2002 accepts brace pipes sizes 1½" and 2" steel schedule 100 through schedule 40.

Material — Carbon Steel

Function — For bracing pipe against sway and seismic disturbance. The pipe attachment component of a sway brace system: The Fig. 2002 is used in conjunction with a TOLCO 900 Series sway brace attachments and joined together with bracing pipe. Install per NFPA 13 and/or TOLCO State of California OSHPD Approved Seismic Restrain Manual.

Features — Unique design will not damage thin wall, plastic, copper or ductile iron pipe. Easy verification of proper installation by tightening bolts until ears touch.

Installation — Place Fig. 2002 over pipe to be braced. Slide bracing pipe through attachment and tighten hex nuts until ears touch.

Approvals — Underwriter's Laboratories Listed in the USA (**UL**) and Canada (**cUL**). Included in our Seismic Restraints Catalog approved by the State of California Office of Statewide Health Planning and Development (**OSHPD**). For additional load, spacing and placement information relating to OSHPD projects, please refer to the TOLCO Seismic Restraint Systems Guidelines.

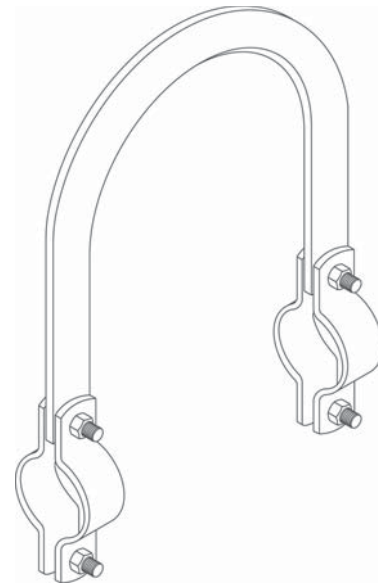
Finish — Plain

Note — Available in Electro-Galvanized and HDG finish.

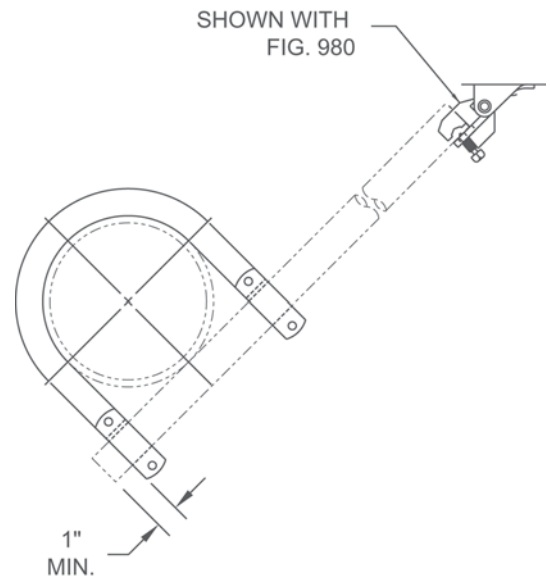
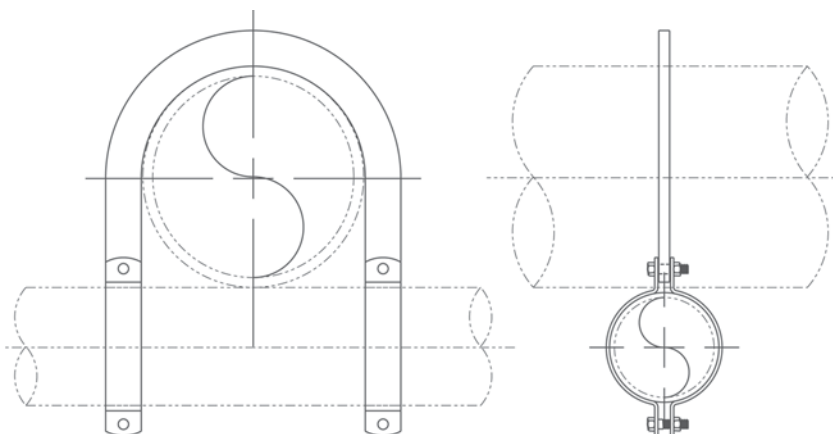
Order By — Figure number, pipe size to be braced, pipe size used for bracing (1½" or 2") and finish.

Important Note — The Fig. 2002 is precision manufactured to perform its function as a critical component of a complete bracing assembly. **To ensure performance, the UL Listing requires that the Fig. 2002 must be used only with other TOLCO bracing products.**

Component of State of California OSHPD Approved Seismic Restraints System



Maximum Design Load 2015 Lbs.



Reference

Material

Included in our Seismic Restraints Catalog approved by the State of California Office of Statewide Health Planning and Development (OSHPD). For additional load, spacing and placement information relating to OSHPD projects, please refer to the TOLCO Seismic Restraint Systems Guidelines.

TOLCO® Cross Reference Chart

TOLCO	GRINNELL & ANVIL	B-LINE	ERICO	PHD	SUPER STRUT	CARPENTER & PATERSON	EMPIRE INDUSTRIES
1	260	B3100	400	450	C710	100	11
1A	300	B3108	415	430	CX710	100EL	11X
1CBS	—	—	—	—	—	—	—
1C.I.	590	B3102	405	420	CH710	100C.I.	11CI
1F	—	B3100F	400FL	450F	C710F	—	—
1LD	65	B3104	410	440	CL710	200	110
1LDF	—	B3104F	410FL	440F	—	—	—
1PVC	—	B3100C	420	453	C710P	100PVC	110PC
1LDPVC	—	B3104C	—	—	—	—	—
1V	—	B3106	—	450V	—	200VT	11V
2	—	B3170	100	151	C727	800	31
2F	—	B3170NFF	100FL	151F	C727F	—	—
2FWON	—	B3172F	—	180F	C725	—	—
2WON	—	B3172	105	180	C727	—	—
3	67	B3690	418	970	C711	—	—
3F	—	B3690F	418FL	97-F	C711F	—	—
4	212	B3140	450	520	C725	175	212
4A	212FP	—	—	—	—	—	—
4B	—	—	—	—	—	—	—
4C.I.	—	—	—	—	—	—	—
4F	—	—	—	—	—	—	—
4H	216	B3142	451	522	—	298	216
4L	—	—	—	—	—	—	—
4PVC	—	—	—	—	—	—	—
5	295	B3144	452	525	C726	304	189
6	261	B3373	510	550	C720	126	50
6F	—	—	—	—	—	—	—
6PVC	—	B3373C	520	553	C720P	126PVC	49PC
7	103	B3148	700	535	C720L	179	95
8	100	B3149	705	545	CX725	267	97
9	600	B3132	517	580	C724	159	97
9X	599	B3132W	516	585	W724	258	599
14	595	B3134	—	590	—	158DB	595
14X	594	B3134W	—	595	—	260	75
20	262	B3180	—	825	164	114	231
20S	—	B3256	—	830	—	—	180
21	—	—	8EG	—	—	—	—
21F	—	—	—	—	—	—	—
22	—	—	107	—	—	—	—
23	—	—	108	—	—	—	—
24	—	—	109	—	—	—	—
25	—	—	—	—	—	—	—
28	—	—	—	—	—	—	—
30	194	B3068	348	—	C736	69	820
30L	—	—	351	850	—	—	—
30M	195	B3066	352	855	C739M	84	801
30H	199	B3067	353	860	C739H	139	802
31-M	—	—	—	—	—	—	—
31-O	—	—	—	—	—	—	—
32	—	B3147	712	840	RCS	127	—
33	47	B3084	373	—	—	—	—
34	49	B3086	374	904	—	—	67
35	52	B3085	374A	903	—	—	68
40	—	B3190	457	820	C704A	227	146
41	—	B3191	458	810	C704	227S	145
42	—	—	319	910	—	152	53

TOLCO[®] Cross Reference Chart

TOLCO	GRINNELL & ANVIL	B-LINE	ERICO	PHD	SUPER STRUT	CARPENTER & PATERSON	EMPIRE INDUSTRIES
50	202	B3060	325	—	540	303	202
51	206	—	—	—	AB201	—	—
52	—	B3070	326	925	542	—	—
58	—	—	—	—	—	—	—
60	227	—	—	—	—	45	159
61	—	B3042	359	—	—	6	158
61T	—	—	—	—	—	—	—
62	133-134	B3050	361	610, 620	C755T-C757T	15	218
64	95	B351L	200	250	C775L	238	21L
65	92	—	300	350	C777	192	62
66	93	B3033	310	—	C778	—	61
68	93	B3033	—	360	M778	—	—
69	89, 87	B3367	255C	359	U568	18	22R
69R	—	—	—	—	—	—	—
70	135	B655	25	100	H119	123	51
70R	136R	B656	25R	105	H119R	123R	51R
70S	—	—	26S	104	—	—	—
71	135	B3220	—	—	—	123W	—
78	128R	B3199	—	940	M742R	95	—
81	CT65	B3104CT	402	442	CTL710	100CT	110CT
81PVC	—	B3104CTC	—	—	—	100PVC	110PC
82	CT121	B3373CT	511	552	CT720	126CT	50CT
82PVC	—	B3373CTC	—	554	—	—	50CTI or 59PC
83	—	B3195CT	—	982	C716	—	—
84	—	B3195CT	—	980	—	—	—
99	—	—	51	10	—	94	54
100	146	—	50	20	H104	—	—
101	278	B3211	40W	55	E157	93	26W
101L	278X	B3211X	—	—	—	341	—
102	248	B3210	40	50	E156	22	26
102L	248X	B3210X	—	—	—	306	—
103	140	B3205	—	15	—	133	57
104	—	B3212	—	60	—	31	—
105	142	B3213	—	40	E151	28	55
106	—	—	46	—	—	—	—
107	—	—	—	70	—	177	77
107F	—	—	—	—	—	—	—
108	—	—	—	—	—	—	81
109A	—	B3019	370A	885	C745	—	—
109F	—	B2501	—	—	—	—	—
110	137	B3188	150	90	H115	283	137
111	120	B3501	—	95, 110	HL115	222	—
113	—	—	10	110	E145	165	56
114	—	—	10H	110H	—	103	52
115	—	—	11	130	E147	103	52
116	—	B3234	—	135	—	706	72
117	—	—	13	134	E148	176	52L
118	60	B3248	340	960	C781	102	75
119	—	—	12	136	EF147	—	52F
120	—	—	—	80	—	44	—
120MJ	—	—	—	—	—	—	—
120RWAA	—	—	—	—	—	—	—
120RWAB	—	—	—	—	—	—	—
120W	—	—	—	—	—	—	—
122	—	—	—	—	—	—	—
123	—	—	—	—	—	59	83
124	—	—	—	—	—	—	84

TOLCO[®] Cross Reference Chart

TOLCO	GRINNELL & ANVIL	B-LINE	ERICO	PHD	SUPER STRUT	CARPENTER & PATERSON	EMPIRE INDUSTRIES
125	—	DS16	43	48	E151D	166	59
126	—	B3228	42	45	E150S	—	—
130	—	—	356	—	—	—	—
200	69	B3170NF	130	—	—	800	31
200WON	—	105	—	—	—	1A	310
202	CT69	B3170CT	101	—	CT727	800CT	C10CTI
203	—	B3170CTC	102	153	CT727P	800PVC	—
207	—	—	—	—	—	—	—
209	—	—	—	47W	—	—	—
210	—	—	—	47D	—	—	—
219	168	—	—	160	—	—	—
220	167	B3151	125	170	C790	265P	167
244H	—	—	126	165	—	—	—
244HR	—	—	—	—	—	—	—
244C	—	—	127	165	—	—	—
244CR	—	—	—	—	—	—	—
260-1	160	B3160	630	651	C789	351	1900
261-1½	161	B3161	631	653	C789A	352	1901
262-2	162	B3162	632	654	C789B	353	1902
263-2½	163	B3163	633	655	C789C	354	1903
264-3	164	B3164	634	656	C789D	355	1904
265-4	165	B3165	635	658	C789E	356	1905
301CT	CT138R	B3198HCT	456	512H	MT718	81CT	41HCT
302	138R	B3198H	455	508	M718	—	41H
304	66	B3083WO	320L	900-1	C789W/O	—	—
305	66	B3083WO	320W	900	C780W/HW	—	—
306	114	B3224	—	44	—	38	114
307	110R	B3222	47	32	E120	12	47
309	181	B3014	282	950	—	—	—
309N	—	B3014N	282N	950N	—	650-266-75	—
310	282	B2500	355	—	452	—	—
310N	285N	N2500	355N	—	AB102	—	—
312	102	B3096	—	875	—	137	422
313	191	B3092	724	880	—	—	—
315	—	B3093	722	882	C786	137	425 or 427
316	—	B3088	—	—	—	—	—
316T	—	B3088T	—	871	—	—	—
317	—	B3095	720	880	—	—	420
317A	264	B3093	—	875	C786	—	426
318A	—	B3092	—	876	—	—	427
318	259	B3090	721	882	C785	125	427
322	171	B3114R	605	490	—	—	277
323	—	B3121	621	—	C729-2½	110	271
324	181	B3110	610	470	C729-2	140	272
325	175	B3120	615	460	CR729A	39	275
326	177	B3122	620	480	RC729	109	274
327	271	B3117SL	617	486	C730C	—	279S
328	274	B3118SL	619	487	C730D	53	280S
329	218, 229	B3054	360	630	M732	293	229
330	290	B3200	35	35	E120A	—	131
331	230	B3202	30	960	F112	132	320
332	299	B3201	31	38	F111	276	909
333	157	B3203	26	25	M129	—	157
335	217	B3045	369	—	C769	92	156
336	14	B3040	363	635	—	14	155
337	—	B3082	321	—	C747	—	—

TOLCO® Cross Reference Chart

TOLCO	GRINNELL & ANVIL	B-LINE	ERICO	PHD	SUPER STRUT	CARPENTER & PATERSON	EMPIRE INDUSTRIES
343	55	B3080	371	936	—	220	69
405	—	B3256	—	—	—	—	—
406	—	B3257	—	—	—	—	—
420	—	—	650	—	—	—	—
421	256	B3281	651	670-678	PG794	—	—
421C	—	—	—	—	—	—	—
422	255	—	—	—	—	—	—
425	—	—	—	—	—	—	—
426	280	B3891	640	690	—	—	4000 Series
427	436	—	—	—	—	—	—
428	437	—	—	—	—	—	—
429	438-1	B3891	640-1	690-1	—	—	4100 Series
430	438-2	B3892	640-2	690-2	—	—	—
431	438-3	B3893	640-3	690-3	—	—	—
432	—	—	—	—	—	—	—
500	178	B3264	625	—	—	478	—
505	247	—	—	—	—	—	—
506	—	—	—	—	—	—	35
568	B268	—	—	—	—	568	—
580	80-V	—	—	—	—	—	—
581	81H	—	—	—	—	—	—
582	82A-G	—	—	—	—	—	—
598	98A-G	—	—	—	—	—	—
650	296	—	—	—	—	—	—
800	—	—	—	—	—	—	—
825	—	—	—	—	—	—	—
825A	—	—	—	—	—	—	—
906	—	—	—	—	—	—	—
907	—	—	—	—	—	—	—
909	—	—	—	—	—	—	—
910	112	—	335AB	—	—	—	—
975	—	—	335A	890 —	—	—	—
980	—	—	—	—	—	—	—
981	—	—	—	—	—	—	—
990	—	—	—	—	—	—	—
991	—	—	—	—	—	—	—
1000	—	—	—	—	—	—	—
1001	—	—	—	—	—	—	—
2002	—	—	—	—	—	—	—

Cross Reference Chart - Grinnell to TOLCO®

GRINNELL	TOLCO	GRINNELL	TOLCO	GRINNELL	TOLCO	GRINNELL	TOLCO
14	336	178	500	—	1CBS	—	120W
47	33	181	324	—	1F	—	122
49	34	191	313	—	1LDF	—	123
52	35	192	312	—	2	—	124
55	343	194	30	—	2F	—	125
60	118	195	30M	—	2FWON	—	126
65	1LD	199	30H	—	2WON	—	130
CT65	81	202	50	—	3F	—	200WON
66	305	206	51	—	4B	—	203
67	3	212	4	—	4C.I.	—	207
69	200	212FP	4A	—	4F	—	209
CT69	202	216	4H	—	6F	—	210
80-V	580	217	335	—	20S	—	244H
81H	581	227	60	—	21	—	244HR
82A-G	582	230	331	—	21F	—	244C
89, 87	69	247	505	—	22	—	244CR
92	65	248	102	—	23	—	315
93	66	248X	102L	—	24	—	316
95	64	255	422	—	25	—	317
98A-G	598	256	421	—	30L	—	316T
100	8	257	426	—	31M	—	318/319
103	7	259	318	—	31O	—	323
108	303	260	1	—	32	—	337
110R	307	261	6	—	40	—	405
112	910	262	20	—	41	—	406
114	306	264	317/319	—	42	—	420
120	111	B268	568	—	52	—	421
CT121	82	271	327	—	58	—	425
CT138R	301CT	274	328	—	61	—	432
128R	78	278	101	—	69R	—	506
133-134	62	278X	101L	—	70S	—	800
135	70, 71	280	426	—	83	—	825
136R	70R	282	309, 309N	—	84	—	825A
137	110	285N	310N	—	99	—	906
138R	302	290	330	—	104	—	907
140	103	295	5	—	106	—	909
142	105	296	650	—	107	—	975
146	100	299	332	—	107F	—	980
157	333	300	1A	—	108	—	981
160	260-1	436	427	—	109	—	990
161	261-1 ¹ / ₂	437	428	—	109F	—	991
162	262-2	438-1	429	—	113	—	1000
163	263-2 ¹ / ₂	438-2	430	—	114	—	1001
164	264-3	438-3	431	—	115	—	2002
165	265-4	590	1C.I.	—	116		
167	220	594	14X	—	117		
168	219	595	14	—	119		
171	322	599	9X	—	120		
175	325	600	9	—	120MJ		
177	326	218, 229	329	—	120RWA		

Cross Reference Chart - B-Line to TOLCO®

B-LINE	TOLCO	B-LINE	TOLCO	B-LINE	TOLCO	B-LINE	TOLCO
DS16	125	B3121	323	B3256	405	—	120
B351L	64	B3122	326	B3257	406	—	120MJ
B655	70	B3132	9	B3264	500	—	120RWA
B656	70R	B3132W	9X	B3281	421	—	120W
B2500	310	B3134	14	B3367	69	—	122
N2500	310N	B3134W	14X	B3373	6	—	123
B2501	109F	B3140	4	B3373C	6PVC	—	124
B3014	309	B3142	4H	B3373CT	82	—	130
B3014N	309N	B3144	5	B3373CTC	82PVC	—	200
B3019	109	B3147	32	B3501	111	—	200WON
B3033	68	B3148	7	B3690	3	—	207
B3040	336	B3149	8	B3690F	3F	—	209
B3042	61	B3151	220	B3891	426	—	210
B3045	335	B3160	260-1	B3892	430	—	219
B3050	62	B3161	216-1 ^{1/2}	B3893	431	—	244H
B3054	329	B3162	262-2	—	1CBS	—	244HR
B3060	50	B3163	263-2 ^{1/2}	—	4A	—	244C
B3066	30M	B3164	264-3	—	4B	—	244CR
B3067	30H	B3165	265-4	—	4C.I.	—	420
B3068	30	B3170	2	—	4F	—	421C
B3070	52	B3170CT	202	—	6F	—	422
B3080	343	B3170CTC	203	—	20S	—	425
B3082	337	B3170NFF	2F	—	21	—	427
B3083WO	304	B3172	2WON	—	21F	—	428
B3083	305	B3172F	2FWON	—	22	—	432
B3084	33	B3173	303	—	23	—	505
B3085	35	B3180	20	—	24	—	506
B3086	34	B3188	110	—	25	—	568
B3088	316	B3190	40	—	30L	—	580
B3088T	316T	B3191	41	—	31M	—	581
B3090	318	B3195CT	83	—	31O	—	582
B3092	318/319	B3198H	302	—	42	—	598
B3093	317/319	B3198HCT	301CT	—	51	—	650
B3095	317	B3199	78	—	58	—	800
B3096	312	B3200	330	—	60	—	825
B3100	1	B3201	332	—	65	—	825A
B3100C	1PVC	B3202	331	—	66	—	906
B3100F	1F	B3203	333	—	69R	—	907
B3102	1C.I.	B3205	103	—	70S	—	909
B3104	1LD	B3210	102	—	84	—	910
B3104C	1LDPVC	B3210X	102L	—	99	—	975
B3104CT	81	B3211	101	—	100	—	980
B3104CTC	81PVC	B3211X	101L	—	106	—	981
B3104F	1LDF	B3212	104	—	107	—	990
B3106	1V	B3213	105	—	107F	—	991
B3108	1A	B3220	71	—	108	—	1000
B3110	324	B3224	306	—	113	—	1001
B3114	322	B3228	126	—	114	—	2002
B3117SL	327	B3234	116	—	115	—	
B3118SL	328	B3248	118	—	117	—	

Cross Reference Chart - MCO to TOLCO®

MCO	TOLCO	MCO	TOLCO	MCO	TOLCO	MCO	TOLCO
8EG	21	356	130	651	421	—	120MJ
10	113	359	61	700	7	—	120RWAA
10H	114	360	329	705	8	—	120RWAB
11	115	361	62	712	32	—	120W
12	119	363	336	720	317	—	122
13	117	367	335	721	318	—	123
25	70	370A	109	722	315	—	124
25R	70R	371	343	724	313	101	202
25S	70S	373	33	—	1CBS	—	207
26	333	374	34	420	1PVC	—	209
30	331	374A	35	—	1LDPVC	—	210
31	332	400	1	—	1V	—	219
35	330	400FL	1F	—	2FWON	—	244HR
40	102	402	81	—	4A	—	244CR
40W	101	40	1C.I.	—	4B	—	303
42	126	410	1LD	—	4C.I.	—	306
43	125	410FL	1LDF	—	4F	—	312
46	106	41	1A	—	6F	—	316
47	307	418	3	520	6PVC	—	316T
50	100	418FL	3F	—	14	—	317/319
51	99	450	4	—	14X	—	318/319
100	2	451	4H	—	20S	—	405
100FL	2F	452	5	—	21F	—	406
102	203	455	302	107	22	—	421C
105	200WON	456	301CT	108	23	—	422
125	220	457	40	109	24	—	425
126	244H	458	41	—	25	—	427
127	244C	470	20	—	31M	—	428
130	200	510	6	—	31O	—	432
150	110	511	82	—	51	—	505
200	64	516	9X	—	58	—	506
255C	69	517	9	—	60	—	568
282	309	605	322	—	68	—	580
282N	309N	610	324	—	69R	—	581
300	64	615	325	—	71	—	582
310	66	617	327	—	78	—	598
319	42	619	328	—	81PVC	—	650
320L	304	620	326	—	82PVC	—	800
320W	305	621	323	—	83	—	825A
321	337	625	500	—	84	—	906
325	50	630	260-1	—	101I	—	907
326	52	631	261-1½	—	102L	—	909
335A	975	632	262-2	—	103	—	980
335AB	910	633	263-2½	—	104	—	981
340	118	634	264-3	—	107	—	990
348	30	635	265-4	—	107F	—	991
351	30L	640	426	—	108	—	1000
352	30M	640-1	429	—	109F	—	1001
353	30H	640-2	430	—	111	—	2001
355	310	640-3	431	—	116	—	
355N	310N	651	421	—	120	—	

Cross Reference Chart - PHD to TOLCO[®]

PHD	TOLCO	PHD	TOLCO	PHD	TOLCO	PHD	TOLCO
10	99	480	326	925	52	—	122
15	103	486	327	930	118	—	124
20	100	487	328	936	343	—	130
25	333	490	322	940	78	—	200
32	307	500	303	950	309	—	200WON
35	330	508	302	950N	309N	—	202
38	332	512H	301CT	960	331	—	207
40	105	520	4	970	3	—	244HB
44	306	522	4H	970F	3F	—	244CR
45	126	525	5	980	84	—	310
47D	210	535	7	982	83	—	310N
47W	209	545	8	—	1CBS	—	316
48	125	550	6	—	1LDPVC	—	323
50	102	552	82	—	4A	—	335
55	101	553	6PVC	—	4B	—	337
60	104	554	82PVC	—	4PVC	—	405
70	107	580	9	—	4C.I.	—	406
80	120	585	9X	—	4F	—	420
90	110	590	14	—	4L	—	421C
95, 110	111	595	14X	—	6F	—	422
100	70	610, 620	62	—	21	—	425
104	70S	630	329	—	21F	—	427
105	70R	635	336	—	22	—	428
110	113	651	260-1	—	23	690-1	429
110H	114	653	261-1½	—	24	690-2	430
130	115	654	262-2	—	25	690-3	431
134	117	655	263-2½	—	28	—	432
135	116	656	264-3	—	30	—	500
136	119	658	265-4	—	31M	—	505
151	2	670-678	421	—	31O	—	506
151F	2F	690	426	—	33	—	568
153	203	810	41	—	50	—	580
160	219	820	40	—	51	—	581
165	244H/244C	825	20	—	58	—	582
170	220	830	20S	—	60	—	598
180	2WON	840	32	—	61	—	650
180F	2FWON	850	30L	—	61T	—	800
250	64	855	30M	—	66	—	825
350	65	860	30H	—	69R	—	825A
359	69	871	316T	—	71	—	906
360	69	875	317/319	—	81PVC	—	907
420	1C.I.	876	318/319	—	101L	—	909
430	1A	880	317	—	102L	—	910
440	1LD	882	318	—	106	—	980
440F	1LDF	885	109	—	107F	—	981
450	1	890	975	—	108	—	990
450F	1F	900	305	—	109F	—	1000
450V	1V	900-1	304	—	120MJ	—	1001
453	1PVC	903	35	—	120RWAA	—	2002
460	325	904	34	—	120RWAB	—	
470	324	910	42	—	120W	—	

Cross Reference Chart - Super Strut to TOLCO®

SUPER STRUT	TOLCO	SUPER STRUT	TOLCO	SUPER STRUT	TOLCO	SUPER STRUT	TOLCO
AB102	310N	C727F	2F	—	23	—	306
F111	332	CT727	202	—	24	—	309
F112	331	CT727P	203	—	25	—	309N
H104	100	C729-2	324	—	28	—	312
H115	110	C729-2½	323	—	30L	—	313
H119	70	CF729A	325	—	31M	—	316
H119R	70R	RC729	326	—	31O	—	316T
HL115	111	C730C	327	—	33	—	317
E120	307	C730D	328	—	34	—	318/319
E120A	330	M732	329	—	35	—	322
M129	333	C736	30	—	42	—	336
E145	113	C739H	30H	—	58	—	343
E147	115	C739M	30M	—	60	—	405
EF147	119	M742R	78	—	61	—	406
E148	117	C747	337	—	61T	—	420
E150S	126	C755T-C757T	62	—	69R	—	421C
E151	105	C777	65	—	70S	—	422
E151D	125	C769	335	—	71	—	425
E156	102	C775L	64	—	81PVC	—	426
E157	101	C778	66	—	82PVC	—	427
164	20	M778	68	—	84	—	428
AB201	51	C780W/HW	305	—	89	—	429
C475	109	C780W/O	304	—	101L	—	430
452	310	C781	118	—	102L	—	431
540	50	C785	318	—	103	—	432
542	52	C786	317/319	—	104	—	500
U568	69	C789	260-1	—	106	—	505
C704	41	C789A	260-1½	—	107	—	506
C704A	40	C789B	262-2	—	107F	—	568
C710	1	C789C	263-2½	—	108	—	580
C710F	1F	C789D	264-3	—	109F	—	581
C710P	1PVC	C789E	265-4	—	114	—	582
CI710	1C.I.	C790	220	—	116	—	598
CL710	1LD	PG794	421	—	120	—	650
CTL710	81	RCS	32	—	120MJ	—	800
CX710	1A	—	1CBS	—	120RWA	—	825
C711	3	—	1LDF	—	120W	—	825A
C711F	3F	—	1LDPVC	—	122	—	906
C716	83	—	1V	—	123	—	907
M718	302	—	4B	—	124	—	909
C720	6	—	4C.I.	—	130	—	910
C720L	7	—	4F	—	200	—	975
C720P	6PVC	—	4H	—	200WON	—	980
CT720	82	—	4L	—	207	—	981
C724	9	—	4PVC	—	209	—	990
W724	9X	—	6F	—	210	—	991
C725	2FWON	—	14	—	219	—	1000
C725	4	—	20S	—	244HR	—	1001
C726	5	—	21	—	244C	—	2002
C727	2	—	21F	—	244CR	—	
C727	2WON	—	22	—	303	—	

Cross Reference Chart - Carpenter & Paterson to TOLCO®

CARPENTER & PATERSON	TOLCO	CARPENTER & PATERSON	TOLCO	CARPENTER & PATERSON	TOLCO	CARPENTER & PATERSON	TOLCO
6	61	267	8	—	4PVC	—	302
12	307	276	332	—	6F	—	303
14	336	283	110	—	20S	—	304
15	62	293	329	—	21	—	305
18	69	298	4H	—	21F	—	309
28	105	303	50	—	22	—	310
31	104	304	5	—	23	—	310N
33	102	306	102L	—	24	—	313
38	306	341	101L	—	25	—	316
39	325	351	260-1	—	27	—	316T
44	120	352	260-1½	—	27A	—	317
45	60	353	262-2	—	28	—	317/319
53	328	354	263-2½	—	30L	—	318/319
59	123	355	264-3	—	31-M	—	322
69	30	356	265-4	—	31-O	—	327
84	30M	399	568	—	33	—	330
85	78	478	500	—	34	—	333
92	335	706	116	—	35	—	337
93	101	800	2	—	51	—	405
94	99	800	200	—	52	—	406
100	1	100C.I.	1C.I.	—	58	—	421
102	118	100CT	81	—	61T	—	421C
103	115	100EL	1A	—	66	—	422
109	326	100PVC	1PVC	—	68	—	425
110	323	100PVC	81PVC	—	69R	—	426
114	20	123R	70R	—	70S	—	427
123	70	123W	71	—	82PVC	—	428
125	318	126CT	82	—	83	—	429
126	6	126PVC	6PVC	—	84	—	430
127	32	158DB	14	—	100	—	431
132	331	1A	200WON	—	106	—	432
133	103	200VT	1V	—	107F	—	505
137	312	227S	41	—	108	—	506
137	315	265P	220	—	109	—	580
139	30H	650-266-75	309N	—	114	—	581
140	324	800CT	202	—	119	—	582
152	42	800PVC	203	—	120MJ	—	598
158	9	81CT	301CT	—	120RWAA	—	650
165	113	—	1CBS	—	120W	—	800
166	125	—	1F	—	122	—	825A
175	4	—	1LDF	—	124	—	906
176	117	—	1LDPVC	—	126	—	907
177	107	—	2F	—	130	—	910
179	7	—	2FWON	—	207	—	975
192	65	—	3	—	209	—	980
200	1LD	—	3F	—	210	—	981
220	343	—	4A	—	219	—	990
222	111	—	4B	—	244H	—	991
227	40	—	4C.I.	—	244HR	—	1000
258	9X	—	4F	—	244C	—	1001
260	14X	—	4L	—	244CR	—	2002

Cross Reference Chart - Empire Industries to TOLCO®

EMPIRE INDUSTRIES	TOLCO	EMPIRE INDUSTRIES	TOLCO	EMPIRE INDUSTRIES	TOLCO	EMPIRE INDUSTRIES	TOLCO
11	1	271	323	—	1LDF	—	126
26	102	272	324	—	1LDPVC	—	203
31	2	273	326	—	2F	—	307
31	200	275	325	—	2FWON	—	210
35	506	277	322	—	3	—	219
47	307	310	200WON	—	3F	—	244H
50	6	320	331	—	4A	—	244HR
51	70	420	317	—	4B	—	244C
52	115	422	312	—	4C.I.	—	244CR
53	42	426	317/319	—	4F	—	303
54	99	427	318/319	—	4L	—	304
55	105	427	318	—	4PVC	—	305
56	113	595	14	—	6F	—	309
57	103	599	9X	—	21	—	310
59	125	600	9	—	21F	—	310N
61	66	801	30M	—	22	—	315
62	65	802	30H	—	23	—	316
67	34	320	30	—	24	—	316T
68	35	909	332	—	25	—	337
69	343	1900	260-1	—	27	—	405
72	116	1901	260-1½	—	27A	—	406
75	14X	1902	262-2	—	28	—	422
75	118	1903	263-2½	—	30L	—	425
77	107	1904	264-3	—	31-M	—	427
80	209	1905	265-4	—	31-O	—	428
81	108	110CT	81	—	33	—	430
83	123	110PC	1PVC	—	51	—	431
84	124	110PC	81PVC	—	52	—	432
95	7	11CI	1C.I.	—	58	—	500
97	8	11V	1V	—	61T	—	505
110	1LD	11X	1A	—	68	—	568
114	306	131	330	—	69R	—	580
137	110	21L	64	—	70S	—	581
145	41	22R	69	—	71	—	582
146	40	26W	101	—	78	—	598
150	130	279S	327	—	83	—	650
155	336	280S	328	—	84	—	800
156	335	310CTI	202	—	100	—	825A
157	333	4000 Series	426	—	101L	—	906
158	61	4100 Series	429	—	102L	—	907
159	60	41H	302	—	104	—	909
167	220	41HCT	301CT	—	106	—	910
180	20S	425 or 427	313	—	107F	—	975
189	5	49PC	6PVD	—	109	—	980
202	50	50CT	82	—	109F	—	981
212	4	50CTI or 49PC	82PVC	—	111	—	990
216	4H	51R	70R	—	114	—	991
218	62	52F	119	—	120	—	1000
229	329	52L	117	—	120MJ	—	1001
231	20	81N	309N	—	120RWAA	—	2002
255	421C	—	1CBS	—	120W	—	
256	421	—	1F	—	122	—	

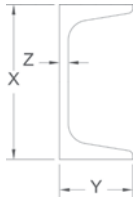
TOLCO[®] to MSS and Federal Specification Cross Reference

TOLCO	MSS-SP-69	Federal Spec. Ww-H-171E
1	Type 1	Type 1
1A	Type 1	Type 1
1LD	—	Type 12
2	Type 10	Type 10
2NFPA	Type 10	Type 10
2WON	Type 7	Type 7
3	Type 5	—
4	Type 4	Type 4
4 CI	Type 4	Type 4
4H	Type 4	Type 4
5	Type 3	Type 3
6	Type 8	Type 8
20	Type 26	Type 26
20S	Type 26	Type 26
30L	Type 31	Type 32
30M	Type 32	Type 33
30H	Type 33	Type 34
62	Type 21	Type 21
64	Type 23	Type 23
65	Type 19	Type 23
66	Type 19	Type 23
68	Type 19	Type 23
81	—	Type 12
82	Type 8	Type 8
110	Type 24	Type 24
200	Type 10	Type 10
200WON	Type 7	Type 7
202	Type 10	Type 10
203	Type 10	Type 10
220	Type 40	Type 41
260-1	Type 39	Type 40A & 40B
261-1½	Type 39	Type 40A & 40B

TOLCO	MSS-SP-69	Federal Spec. Ww-H-171E
262-2	Type 39	Type 40A & 40B
263-2½	Type 39	Type 40A & 40B
264-3	Type 39	Type 40A & 40B
265-4	Type 39	Type 40A & 40B
301CT	Type 12	Type 25
302	Type 12	Type 25
303	Type 11	Type 11
304	Type 22	Type 22
305	Type 22	Type 22
306	Type 15	Type 15
307	Type 16	Type 16
309	Type 18	Type 18
310	Type 18	Type 19
317	Type 36	Type 37
318	Type 37	Type 38
317A	Type 38	Type 39
322	Type 41	Type 42
324	Type 43	Type 44
327	Type 44	Type 45
328	Type 46	Type 47
329	Type 30	Type 30
330	Type 17	Type 17
331	Type 13	Type 13
332	Type 14	Type 14
335	Type 25	Type 53
336	Type 27	Type 54
343	Type 57	—
499	Type 58	—
500	Type 49	Type 50
568	Type 51	Type 51
580	Type 54 & 55	Type 52
582	Type 51	Type 51
598	Type 51	Type 51
650	Type 50	—

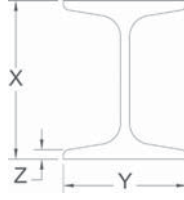
Beam Dimensions

American Standard Channels — C Shapes



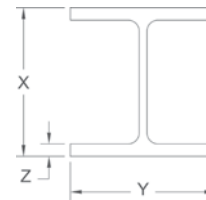
Designation Depth & Wt. "x" Lbs.	Flange Width "Y"	Ave. Thickness "Z"
C3 x 4.1	1½	
C3 x 5.0	1½	.250
C3 x 6.0	1½	
C4 x 5.4	1½	
C4 x 7.25	1¾	.313
C5 x 6.7	1¾	
C5 x 9.0	1½	.313
C6 x 8.2	1⅞	
C6 x 10.5	2	.375
C6 x 13.0	2½	
C7 x 9.8	2½	
C7 x 12.25	2¼	.375
C7 x 14.75	2¼	
C8 x 11.5	2¼	
C8 x 13.75	2¾	.375
C8 x 18.75	2½	
C9 x 13.4	2½	
C9 x 15.0	2½	.438
C9 x 20.0	2½	
C10 x 15.3	2¾	
C10 x 20.0	2¾	.438
C10 x 25.0	2⅞	
C10 x 30.0	3	
C12 x 20.7	3	
C12 x 25.0	3	.500
C12 x 30.0	3⅞	
C15 x 33.9	3¾	
C15 x 40.0	3½	.625
C15 x 50.0	3¾	
C18 x 42.7	4	
C18 x 45.8	4	
C18 x 51.9	4½	.625
C18 x 58.0	4¼	

American Standard I Beams — S Shapes



Designation Depth & Wt. "x" Lbs.	Flange Width "Y"	Ave. Thickness "Z"
S3 x 5.7	2¾	
S3 x 7.5	2½	.250
S4 x 7.7	2¾	
S4 x 9.5	2¾	.313
S5 x 10.0	3	
S5 x 14.75	3¼	.313
S6 x 12.5	3¾	
S6 x 17.25	3¾	.375
S7 x 15.3	3¾	
S7 x 20.0	3¾	.375
S8 x 18.4	4	
S8 x 23.0	4½	.438
S10 x 25.4	4¾	
S10 x 35.0	5	.500
S12 x 31.8	5	
S12 x 35.0	5½	.563
S12 x 40.8	5¼	
S12 x 50.0	5½	.688
S15 x 42.9	5½	
S15 x 50.0	5¾	.625
S18 x 54.7	6	
S18 x 70.0	6¼	.688
S20 x 66.0	6¼	
S20 x 75.0	6¾	.813
S20.3 x 86.0	7	
S20.3 x 96.0	7¼	.938
S24 x 80.0	7	
S24 x 90.0	7½	.875
S24 x 100.0	7¼	

American Standard Wide Flange — W Shapes



Designation Depth & Wt. "x" Lbs.	Flange Width "Y"	Ave. Thickness "Z"	Designation Depth & Wt. "x" Lbs.	Flange Width "Y"	Ave. Thickness "Z"
W4 x 13	4	.375	W14 x 99	14½	.780
W5 x 19	5	.430	W14 x 109	14½	.860
W6 x 25	5½	.455	W14 x 120	14½	.940
W8 x 18	5¼	.330	W14 x 132	14¾	1.030
W8 x 21	5¼	.400	W16 x 36	7	.630
W8 x 24	6½	.400	W16 x 40	7	.505
W8 x 28	6½	.465	W16 x 45	7	.565
W8 x 31	8	.435	W16 x 50	7½	.630
W8 x 35	8	.495	W16 x 57	7½	.715
W8 x 40	8½	.560	W16 x 67	10¼	.665
W8 x 48	8½	.685	W16 x 77	10¼	.760
W8 x 58	8¼	.810	W16 x 89	10¾	.875
W8 x 67	8¼	.935	W16 x 100	10¾	.985
W10 x 22	5¾	.360	W18 x 50	7½	.570
W10 x 26	5¾	.440	W18 x 55	7½	.630
W10 x 33	8	.435	W18 x 60	7½	.695
W10 x 39	8	.530	W18 x 65	7½	.750
W10 x 45	8	.620	W18 x 71	7½	.810
W10 x 49	10	.560	W18 x 76	11	.680
W10 x 54	10	.615	W18 x 86	11½	.770
W10 x 60	10½	.680	W18 x 97	11½	.870
W10 x 68	10½	.770	W18 x 106	11¼	.940
W10 x 77	10¼	.870	W21 x 62	8¼	.615
W10 x 88	10¼	.990	W21 x 68	8¼	.685
W12 x 26	6½	.380	W21 x 73	8¼	.740
W12 x 30	6½	.440	W21 x 83	8¾	.835
W12 x 35	6½	.520	W21 x 93	8¾	.930
W12 x 40	8	.515	W21 x 101	12¼	.800
W12 x 45	8	.575	W21 x 111	12¾	.875
W12 x 50	8½	.640	W21 x 122	12¾	.960
W12 x 53	10	.575	W24 x 76	9	.680
W12 x 58	10	.640	W24 x 84	9	.770
W12 x 65	12	.605	W24 x 94	9½	.875
W12 x 72	12	.670	W24 x 104	12¾	.750
W12 x 79	12½	.735	W24 x 117	12¾	.850
W12 x 87	12½	.810	W24 x 131	12¾	.960
W12 x 96	12½	.900	W27 x 94	10	.745
W12 x 106	12¼	.990	W27 x 102	10	.830
W14 x 30	6¾	.385	W27 x 114	10½	.930
W14 x 34	6¾	.455	W27 x 146	14	.975
W14 x 38	6¾	.515	W30 x 108	10½	.760
W14 x 43	8	.530	W30 x 116	10½	.850
W14 x 48	8	.595	W30 x 134	10½	.930
W14 x 53	8	.660	W30 x 132	10½	1.000
W14 x 61	10	.645	W33 x 118	11½	.740
W14 x 68	10	.720	W33 x 130	11½	.855
W14 x 74	10½	.785	W33 x 141	11½	.960
W14 x 82	10½	.855	W36 x 135	12	.790
W14 x 90	14½	.710	W36 x 150	12	.940
			W36 x 160	12	1.020

Decimals of a Foot

Inch	0"	1"	2"	3"	4"	5"	6"	7"	8"	9"	10"	11"
0	0	.0833	.1667	.2500	.3330	.4167	.5000	.5833	.6667	.7500	.8333	.9167
1/16	.0052	.0085	.1719	.2552	.3385	.4219	.5052	.5885	.6719	.7552	.8385	.9219
1/8	.0104	.0938	.1771	.2604	.3438	.4271	.5104	.5938	.6771	.7604	.8438	.9271
3/16	.0156	.0990	.1823	.2656	.3490	.4323	.5156	.5990	.6823	.7656	.8490	.9323
1/4	.0208	.1042	.1875	.2708	.3542	.4375	.5208	.6042	.6875	.7708	.8542	.9375
5/16	.0260	.1094	.1927	.2760	.3594	.4427	.5260	.6094	.6927	.7760	.8594	.9427
3/8	.0313	.1146	.1979	.2812	.3646	.4479	.5313	.6146	.6979	.7813	.8646	.9479
7/16	.0365	.1198	.2031	.2891	.3724	.4557	.5391	.6224	.7057	.7891	.8724	.9557
1/2	.0417	.1250	.2083	.2917	.3750	.4583	.5417	.6250	.7083	.7917	.8750	.9583
9/16	.0469	.1302	.2135	.2969	.3802	.4635	.5469	.6302	.7135	.7969	.8802	.9635
5/8	.0521	.1354	.2188	.3021	.3854	.4688	.5521	.6354	.7188	.8021	.8854	.9688
11/16	.0573	.1406	.2240	.3073	.3906	.4740	.5573	.6406	.7240	.8073	.8906	.9740
3/4	.0625	.1458	.2292	.3125	.3958	.4792	.5625	.6458	.7292	.8125	.8958	.9792
13/16	.0677	.1510	.2344	.3177	.4010	.4844	.5677	.6510	.7344	.8177	.9010	.9844
7/8	.0729	.1563	.2396	.3229	.4063	.4896	.5729	.6563	.7396	.8229	.9063	.9896
15/16	.0781	.1615	.2448	.3281	.4118	.4948	.5781	.6615	.7448	.8221	.9115	.9948

Decimals of an Inch

Fraction		Decimal	Fraction		Decimal	
		1/32	.0312		17/32	.5312
	1/16		.0625		9/16	.5625
		3/32	.0937		19/32	.5937
1/8			.1250	5/8		.6250
		5/32	.1562		21/32	.6562
	3/16		.1875		11/16	.6875
		7/32	.2187		23/32	.7187
1/4			.2500	3/4		.7500
		9/32	.2812		25/32	.7812
	5/16		.3125		13/16	.8125
		11/32	.3437		27/32	.8437
3/8			.3750	7/8		.8750
		13/32	.4062		29/32	.9062
	7/16		.4375		15/16	.9375
		15/32	.4687		31/32	.9687
1/2			.500			

Steel Pipe Data

Schedule 40 & 80

Pipe Size	Sched. No.	O.D.	Wall Thickness	Wt. Per Foot	Water Weight per Ft./Lbs	Pipe Size	Sched. No.	O.D.	Wall Thickness	Wt. Per Foot	Water Weight per Ft. Lbs.
3/8	40	.675	.091	.567	.083	5	40	5.563	.258	14.620	8.660
	80		.126	.738	.061		80		.375	20.780	7.870
1/2	40	.840	.109	.850	.132	6	40	6.625	.280	18.970	12.510
	80		.147	1.087	.101		80		.432	28.570	11.290
3/4	40	1.050	.113	1.130	.230	8	40	8.625	.322	28.550	21.600
	80		.154	1.473	.186		80		.500	43.390	19.800
1	40	1.315	.133	1.678	.374	10	40	10.750	.365	40.480	34.100
	80		.179	2.171	.311		80		.593	64.400	31.100
1¼	40	1.660	.104	2.272	.647	12	40	12.750	.406	53.600	48.500
	80		.191	2.996	.555		80		.687	88.60	44.000
1½	40	1.900	.145	2.717	.882	14	40	14.000	.437	63.00	58.500
	80		.200	3.631	.765		80		.750	107.000	51.200
2	40	2.375	.154	3.652	1.452	16	40	16.000	.500	83.000	76.500
	80		.218	5.022	1.279		80		.843	137.000	69.700
2½	40	2.875	.203	5.790	2.072	18	40	18.000	.563	105.000	97.200
	80		.276	7.660	1.834		80		.937	171.000	88.500
3	40	3.500	.216	7.570	3.200	20	40	20.000	.593	123.000	120.400
	80		.300	10.250	2.860		80		1.031	209.000	109.400
3½	40	4.000	.226	9.110	4.280	24	40	24.000	.687	171.000	174.200
	80		.318	12.510	3.850		80		1.218	297.000	158.200
4	40	4.500	.237	10.790	5.510	30	20	30.000	.500	158.000	286.000
	80		.337	14.980	4.980		36		API	36.000	.500

Copper Tube Data

Type L

Type K

Nom. Tube Size	O.D. Tubing	O.D.	Wall Thickness	Wt. Per Foot	Water Weight per Ft./Lbs	Nom. Tube Size	O.D. Tubing	O.D.	Wall Thickness	Wt. Per Foot	Water Weight per Ft. Lbs.
1/4	3/8	.375	.030	.126	.034	1/4	3/8	.375	.035	.145	.032
3/8	1/3	.500	.035	.198	.062	3/8	1/2	.500	.049	.269	.055
1/2	5/8	.625	.040	.285	.100	1/2	5/8	.625	.049	.344	.094
5/8	3/4	.750	.042	.362	.151	5/8	3/4	.750	.049	.418	.144
3/4	7/8	.875	.045	.455	.209	3/4	7/8	.875	.065	.641	.188
1	1½	1.125	.050	.655	.357	1	1½	1.125	.065	.839	.337
1¼	1¾	1.375	.055	.884	.546	1¼	1¾	1.375	.065	1.040	.527
1½	1½	1.625	.060	1.140	.767	1½	1½	1.625	.072	1.360	.743
2	2½	2.125	.070	1.75	1.341	2	2½	2.125	.083	2.050	1.310
2½	2½	2.625	.080	2.480	2.064	2½	2½	2.625	.095	2.920	2.000
3	3½	3.125	.090	3.330	2.949	3	3½	3.125	.109	4.000	2.960
3½	3½	3.625	.100	4.290	3.989	3½	3½	3.625	.120	5.120	3.900
4	4½	4.125	.110	5.380	5.188	4	4½	4.125	.134	6.510	5.060
5	5½	5.125	.125	7.610	8.081	5	5½	5.125	.160	9.670	8.000
6	6½	6.125	.140	10.200	11.616	6	6½	6.125	.192	13.870	11.200

Cast Iron Pipe Data

American Water Works Assn. (AWWA)

Mechanical Joint Pipe Class 150. Approximately same weight for Bell & Spigot. Flanged cast iron pipe add weight of flanges

Pipe Size	O.D. C.I. Pipe	Wall Thickness	Wt. Per Foot	Wt. of Water per Ft./Lbs.
3	3.96	.32	12.2	3.73
4	4.80	.35	16.4	5.72
6	6.90	.38	25.7	12.80
8	9.05	.41	36.7	23.10
10	11.10	.44	48.7	35.50
12	13.20	.48	62.9	51.00
14	15.30	.51	78.8	69.30
16	17.40	.54	95.0	90.30
18	19.50	.58	114.7	114.00
20	21.60	.62	135.9	141.50
24	25.80	.73	190.4	201.00
30	32.00	.85	277.3	312.00
36	38.30	.94	368.9	449.00
42	44.50	1.05	479.1	612.00
48	50.80	1.14	595.2	803.00

Standard No Hub "Soil Pipe"

Pipe Size	O.D.	I.D.
2	2.25	1.89
3	3.25	2.89
4	4.25	3.89
5	5.25	4.87
6	6.25	5.85
8	8.38	7.94
10	10.50	9.98

Extra Heavy "Soil Pipe"

Pipe Size	O.D.	I.D.
2	2.38	2.00
3	3.50	3.00
4	4.50	4.00
5	5.50	5.00
6	6.50	6.00
8	8.62	8.00
10	10.75	10.00

Load Carrying Capacities of Threaded Steel Rod

Rod Diameter In.	Root Area Thread Sq. In.	Max. Safe Load in Lbs. @650°F*	Max. Rec. Load in Lbs. @ 750°F*	Weight per Ft./Lbs.
3/8	.068	610	540	.376
1/2	.126	1130	1010	.668
5/8	.202	1810	1610	1.040
3/4	.302	2710	2420	1.500
7/8	.419	3770	3360	2.400
1	.552	4960	4420	2.670
1 1/8	.693	6230	5560	3.380
1 1/4	.889	8000	7140	4.170
1 1/2	1.293	11630	10370	6.010
1 3/4	1.744	15700	14000	8.180
2	2.300	20700	18460	10.680
2 1/2	3.023	27200	24260	13.520
2 1/2	3.719	33500	29800	16.960

* Maximum recommended load based on minimum safety factor of 5.

NIBCO®

Fittings

Wrot and cast copper pressure fittings • Wrot and cast copper drainage fittings • Cast copper alloy flared fittings • Cast copper alloy flanges • ABS and PVC DWV fittings • Schedule 40 PVC pressure fittings • CPVC CTS fittings • CPVC CTS-to-metal transition fittings • Schedule 80 PVC and CPVC systems • CPVC metric piping systems • CPVC BlazeMaster® fire protection fittings

BlazeMaster® is a registered trademark of The Lubrizol Corporation.

Valves & Actuation

Pressure-rated bronze, iron and alloy-iron gate, globe and check valves • Pressure-rated bronze ball valves • Boiler specialty valves • Commercial and industrial butterfly valves • Circuit balancing valves • Carbon and stainless steel ball valves • ANSI flanged steel ball valves • Pneumatic and electric actuators and controls • Grooved ball and butterfly valves • High performance butterfly valves • UL/FM fire protection valves • Low-pressure gate, globe, check and ball valves • Bronze specialty valves • Frostproof sillcocks • Quarter-turn supply stops • MSS specification valves • PVC ball valves • CPVC CTS ball valves • Just Right® recirculating valves

Chemtrol®

Thermoplastic pipe, valves and fittings in PVC, Corzan® CPVC, polypropylene and PVDF Kynar® • Pneumatic and electric actuation systems

Corzan® is a registered trademark of The Lubrizol Corporation.
Kynar is a registered trademark of Arkema Inc.

eNIBCO®

A suite of services designed to make customers more efficient • More cost-effective • More informed • EDI—Electronic Data Interchange • VMI—Vendor Managed Inventory • NIBCO.com • NIBCOpartner.com • eNIBCO will continuously develop new products to deliver the competitive advantage

Supporting
the Flow.™



Pipe Hangers • Pipe Supports
TOL-Strut® Channel • Seismic Bracing

Every solution
begins with
TOLCO®.

We're committed to supporting all of your flow control needs. We can provide creative solutions for your most challenging bracing and support applications. Solutions that make your installations easier, safer and more cost-effective.

For solutions that will support your flow-control applications, call on us. We're TOLCO, a product line committed to quality, service and innovation—Supporting the Flow.

TOLCO®

Office / Manufacturing
1375 Sampson Avenue
Corona, California 92879
USA

Phone: 951.737.5599
Fax: 951.737.0330

Customer Service:
Phone: 800.786.5266

www.tolco.com

NIBCO INC.

World Headquarters
1516 Middlebury Street
Elkhart, IN 46515-1167
USA

Customer Service:
Phone: 800.234.0227
Fax: 800.234.0557

Technical Service:
Phone: 888.446.4226

www.nibco.com