



TECHNICAL DATA

GUARDS AND WATER SHIELDS FOR XT1 SPRINKLERS

The Viking Corporation, 210 N Industrial Park Drive, Hastings MI 49058

Telephone: 269-945-9501 Technical Services: 877-384-5464 Fax: 269-818-1680 Email: techsvcs@vikingcorp.com

Visit the Viking website for the latest edition of this technical data page www.vikinggroupinc.com

1. DESCRIPTION

Viking Model XG Sprinkler Guards and XWU Water Shields are used in conjunction with Viking XT1 style sprinklers where allowed by the approvals. (Refer to the Approval Charts) The guards are hard-wire cages designed to encase the sprinklers and protect them from mechanical damage. They are recommended for areas where sprinklers are installed at a low elevation and/or near a high degree of human or mechanical activity.

Water shields protect the sprinkler's heat-sensing operating element from water spray discharge from sprinklers located at a higher elevation. Viking XT1 style sprinklers with Model XWU or F-1 Water Shields and/or XG Guards are converted to intermediate level/rack storage sprinklers. They may be used in any application where water shielding is required, such as in-rack sprinkler systems, under grating, on pilot sprinklers for deluge systems, and outdoors as a weather shield.

NOTE: Sprinkler water shields and guards are not designed to be used on sprinklers installed in recessed escutcheons.

2. LISTINGS AND APPROVALS



cULus Listed: Category VNIV



FM Approved: Class 2091

XG Guard is approved for use with the following sprinklers:

VK1001, VK1021, VK3001, VK3021, VK2002, VK2022, VK3502, VK3522, VK2001, VK2021, VK3501, and VK3521

XWU Water Shield is approved for use on XT1 Upright sprinklers **with XG Guards**:

VK1001, VK3001, VK2002, VK3502, VK2001, and VK3501

F-1 Water Shield is approved for use with XT1 Pendent sprinklers:

VK1021, VK3021, VK2022, VK3521, VK2021, and VK3522

Refer to the Approval Charts for more information.

3. TECHNICAL DATA

Material Standards:

XG Sprinkler Guard: Bright Basic Steel Wire UNS-G10100 or JIS G3141 SPCF

Screw: 6-32 x 3/8 (R.H. Phillips-Slotted Combination Drive): Steel

Screw Finish: Zinc Plated

XWU Water Shield: Cold Rolled Steel UNS-G10080 or JIS G3141 SPCF

F-1 Water Shield: Cold Rolled Steel UNS-G10080



WARNING: Cancer and Reproductive Harm-
www.P65Warnings.ca.gov

TABLE 1: ORDERING INFORMATION AND DIMENSIONS

Guards and water shields must be ordered separately. See below for details.

Refer to the approval charts in this document as well as the appropriate sprinkler Technical Data Page.

Part Number	Description	Size	
		NPT	BSPT
22931	Model XG Sprinkler Guard	1/2" or 3/4"	15 mm or 20mm
22937	Model XWU Upright Water Shield (must be used with Model XG Guard)	--	--
10323	Model F-1 Pendent Water Shield	1/2"	15 mm
10324	Model F-1 Pendent Water Shield	3/4"	20mm



TECHNICAL DATA

GUARDS AND WATER SHIELDS FOR XT1 SPRINKLERS

The Viking Corporation, 210 N Industrial Park Drive, Hastings MI 49058
 Telephone: 269-945-9501 Technical Services: 877-384-5464 Fax: 269-818-1680 Email: techsvcs@vikingcorp.com
 Visit the Viking website for the latest edition of this technical data page www.vikinggroupinc.com

TABLE 2: SPECIFICATIONS				
Part Number	Description	Dimensions		
		A	B	C
22931	XG Sprinkler Guard	2-15/16" (75 mm)	2-3/16" (56 mm)	3/32" (2.3 mm)
22937	XWU Upright Water Shield	3-3/8" (86 mm)	9/16" (14 mm)	1/32" (1 mm)
10323	F-1 Pendent Water Shield (1/2")	3" (75 mm)	0.08" (2 mm)	0.036" (0.9 mm)
10324	F-1 Pendent Water Shield (3/4")	3" (75 mm)	0.08" (2 mm)	0.036" (0.9 mm)

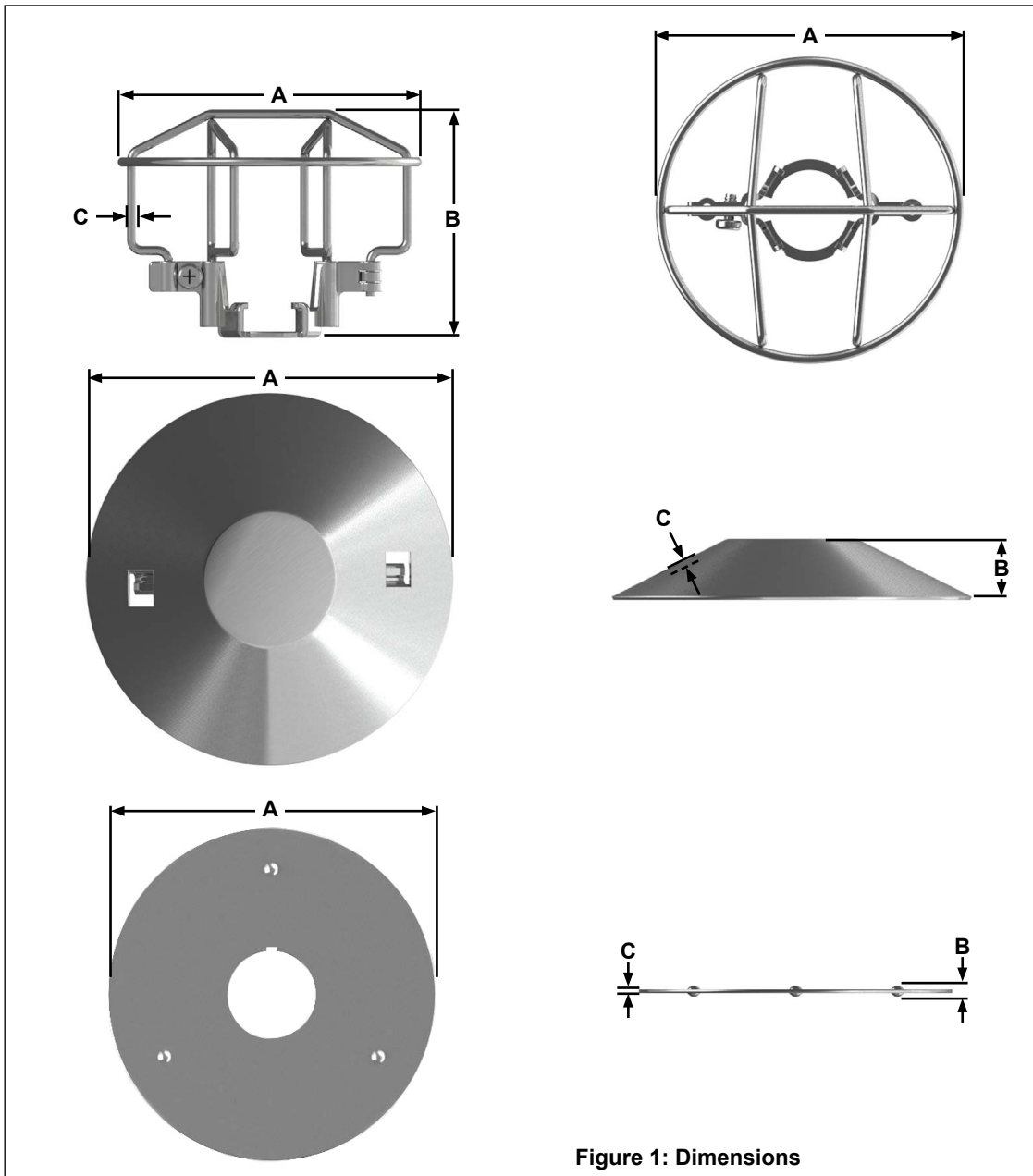

Figure 1: Dimensions



TECHNICAL DATA

GUARDS AND WATER SHIELDS FOR XT1 SPRINKLERS

The Viking Corporation, 210 N Industrial Park Drive, Hastings MI 49058
 Telephone: 269-945-9501 Technical Services: 877-384-5464 Fax: 269-818-1680 Email: techsvcs@vikingcorp.com
 Visit the Viking website for the latest edition of this technical data page www.vikinggroupinc.com

4. INSTALLATION

⚠ DANGER FIRE HAZARD - RISK OF SERIOUS INJURY OR DEATH

Improper installation can impede the sprinkler operation during fire conditions. Fire can lead to serious injury or death.
 ► Follow the procedures in this document to properly install the sprinkler guard.

A. Installing the XG Sprinkler Guard on the Sprinkler

Tools needed:

- R.H. Phillips or Flat Head screwdriver (not available from Viking.)

Procedure:

1. Install the sprinkler into the piping according to the sprinkler's Technical Data sheet.
2. Loosen the screw and open the guard.
3. With the sprinkler frame arms parallel to the vertical guard members, maneuver the guard onto the sprinkler.

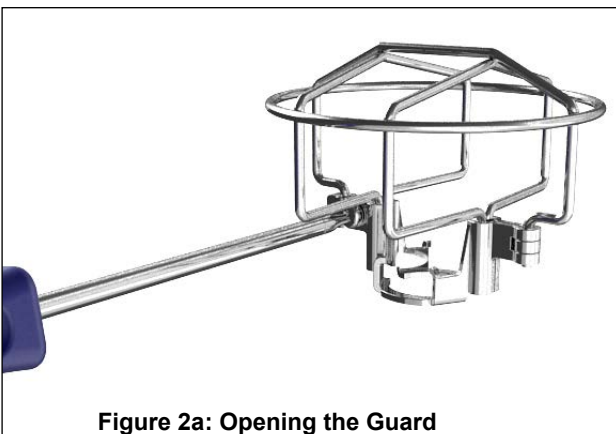

Figure 2a: Opening the Guard

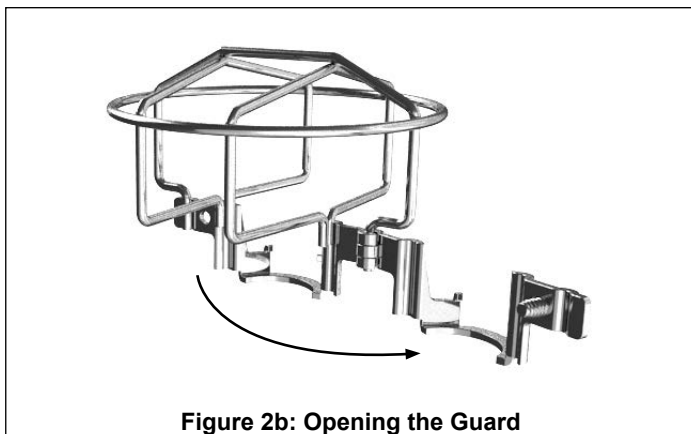

Figure 2b: Opening the Guard

NOTE: For Upright sprinklers, the guard must be oriented and angled as shown (Figure 3a) in order to get the deflector inside the frame.

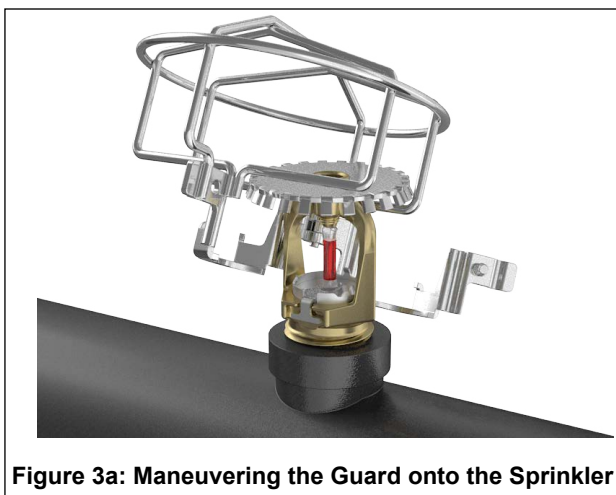

Figure 3a: Maneuvering the Guard onto the Sprinkler

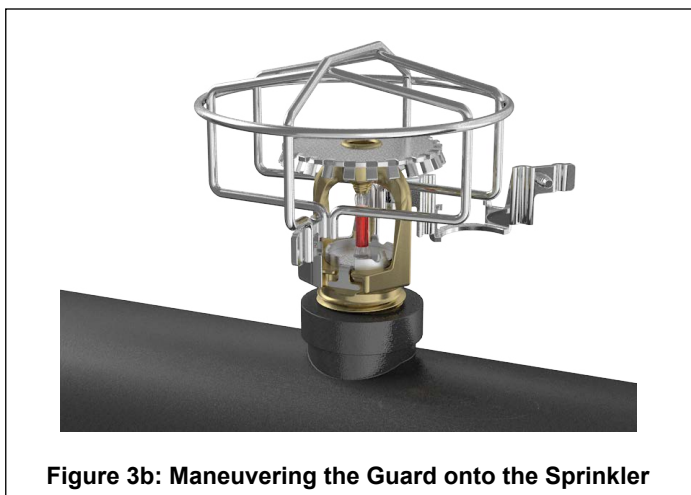

Figure 3b: Maneuvering the Guard onto the Sprinkler



TECHNICAL DATA

GUARDS AND WATER SHIELDS FOR XT1 SPRINKLERS

The Viking Corporation, 210 N Industrial Park Drive, Hastings MI 49058
Telephone: 269-945-9501 Technical Services: 877-384-5464 Fax: 269-818-1680 Email: techsvcs@vikingcorp.com
Visit the Viking website for the latest edition of this technical data page www.vikinggroupinc.com

- 4. Once the sprinkler is inside the frame and the guard is properly oriented, rotate the guard 90 degrees in either direction so the activation element T-hinge is not blocked. See Figures 4 and 5.
- 5. Close the guard and tighten the screw.

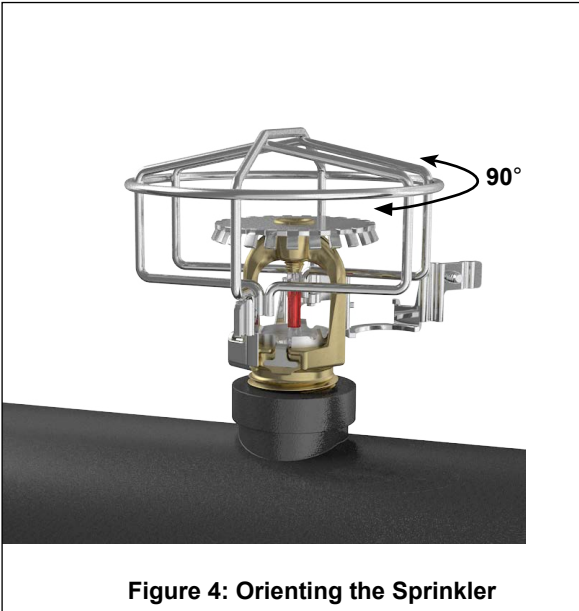

Figure 4: Orienting the Sprinkler

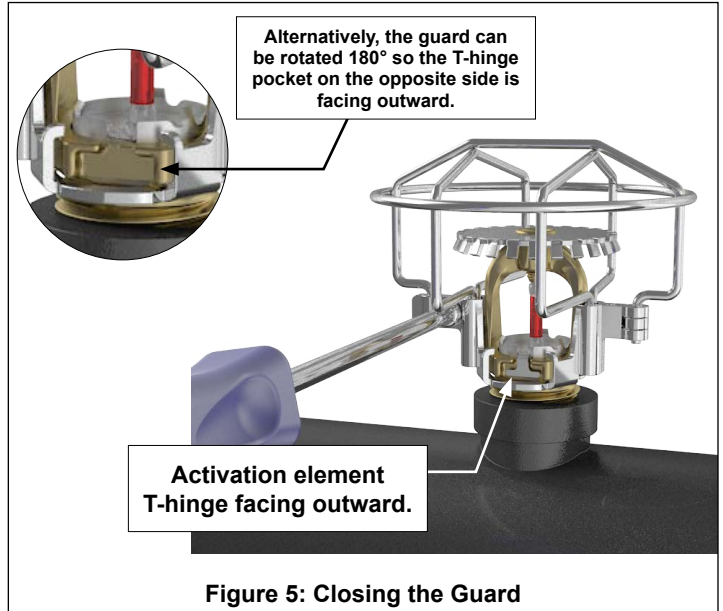

Figure 5: Closing the Guard

6. VERIFY THAT THE SPRINKLER IS PROPERLY ORIENTED WITHIN THE GUARD. SEE FIGURE 6 BELOW.

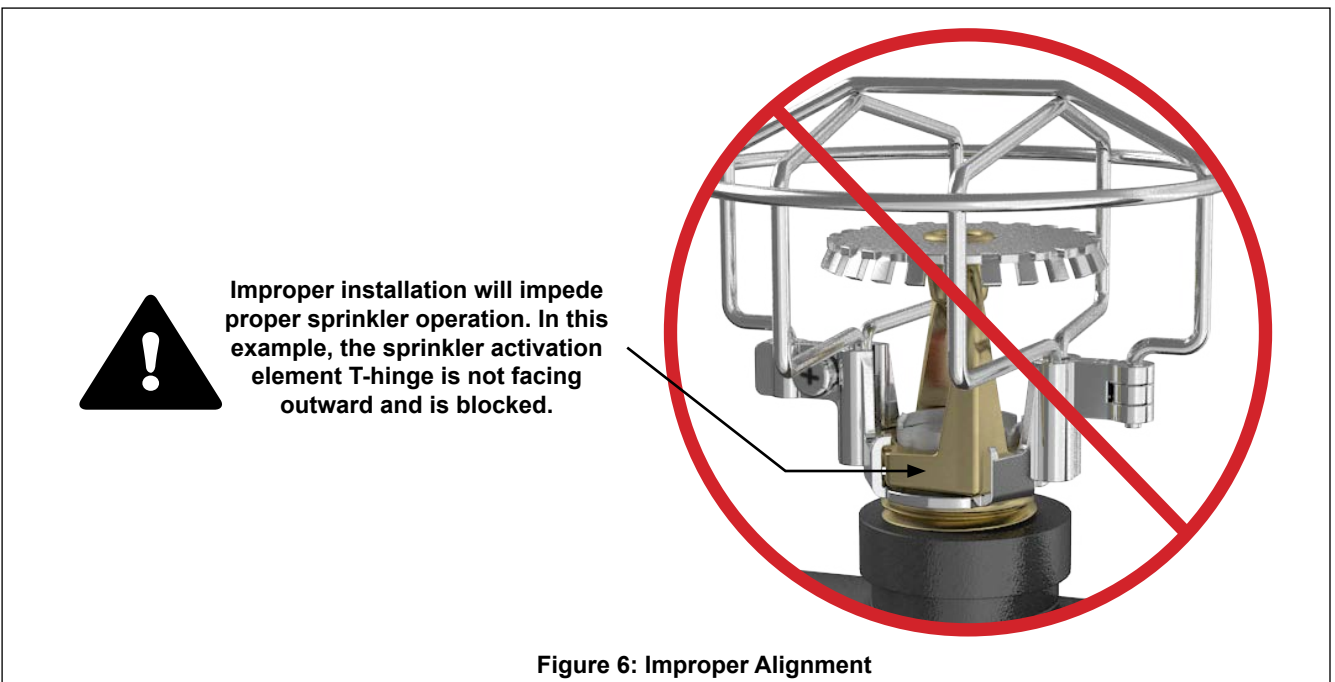

Figure 6: Improper Alignment



TECHNICAL DATA

GUARDS AND WATER SHIELDS FOR XT1 SPRINKLERS

The Viking Corporation, 210 N Industrial Park Drive, Hastings MI 49058
 Telephone: 269-945-9501 Technical Services: 877-384-5464 Fax: 269-818-1680 Email: techsvcs@vikingcorp.com
 Visit the Viking website for the latest edition of this technical data page www.vikinggroupinc.com

B. Installing the XWU Water Shield onto the XG Sprinkler Guard

CAUTION CUTTING HAZARD

The outer edge of the water shield is sharp and can cause cuts.
 ► Avoid sharp edges.

Procedure:

1. Line up the clips to be installed onto the guard frame as shown below.
2. Rotate the water shield a few degrees clockwise to snap the clips onto the guard wires as shown above.

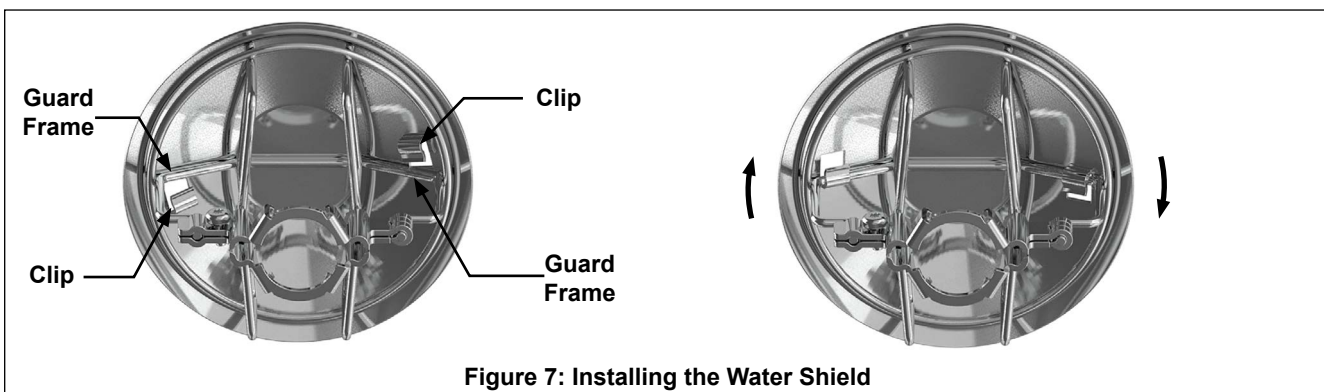

Figure 7: Installing the Water Shield

C. Installing the F-1 Water Shield (and XG Guard, if desired - not shown below)

NOTICE

Use only the designated sprinkler wrench. Refer the appropriate sprinkler's Technical Data sheet.

Tools needed:

- Sprinkler wrench (see Notice above).

Procedure:

1. Install the F-1 Water Shield onto the sprinkler threads as shown below.
2. Install the sprinkler/water shield assembly into the piping according to the sprinkler's Technical Data sheet.
3. After installing the sprinkler/water shield into the pipe, install the XG guard (if applicable) onto the sprinkler as shown in Section 4A.

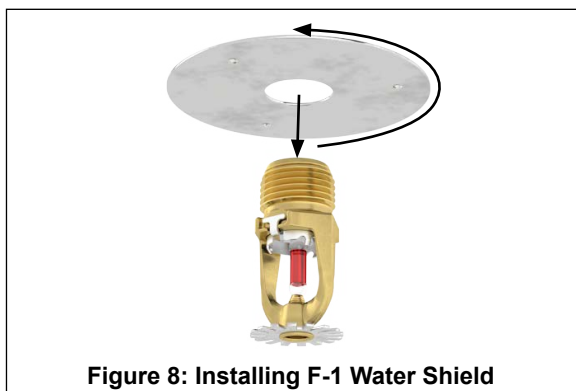

Figure 8: Installing F-1 Water Shield



Figure 9: Sprinkler/Water Shield Installed in Pipe

**TECHNICAL DATA****GUARDS AND WATER
SHIELDS FOR
XT1 SPRINKLERS**

The Viking Corporation, 210 N Industrial Park Drive, Hastings MI 49058

Telephone: 269-945-9501 Technical Services: 877-384-5464 Fax: 269-818-1680 Email: techsvcs@vikingcorp.com

Visit the Viking website for the latest edition of this technical data page www.vikinggroupinc.com

5. OPERATION**NOTICE**

Always refer to Bulletin Form No. F_091699 - Care and Handling of Sprinklers. Also refer to the appropriate sprinkler data page. Viking sprinklers are designed to be installed in accordance with the latest edition of Viking technical data, the latest standards of NFPA, FM Global or other similar organizations, and also with the provisions of governmental codes, ordinances, and standards whenever applicable. The use of certain types of sprinklers may be limited due to occupancy and hazard. Refer to the Authority Having Jurisdiction prior to installation..

Refer to the sprinkler technical data page for the sprinkler model used. Water shields protect the sprinkler's heat-sensing operating element from water spray discharge from sprinklers located at a higher elevation. The Sprinkler Guard is a hard-wire cage designed to encase the sprinkler and protect it from mechanical damage.

6. INSPECTIONS, TESTS AND MAINTENANCE

Refer to NFPA 25 for Inspection, Testing and Maintenance requirements.

7. AVAILABILITY

Viking sprinkler guards and water shields are available through a network of domestic and international distributors. See the Viking website for the closest distributor or contact Viking.

8. GUARANTEE

For details of warranty, refer to Viking's current list price schedule or contact Viking directly.



TECHNICAL DATA

GUARDS AND WATER SHIELDS FOR XT1 SPRINKLERS

The Viking Corporation, 210 N Industrial Park Drive, Hastings MI 49058
 Telephone: 269-945-9501 Technical Services: 877-384-5464 Fax: 269-818-1680 Email: techsvcs@vikingcorp.com
 Visit the Viking website for the latest edition of this technical data page www.vikinggroupinc.com

Approval Chart 1

Upright XT1 Sprinklers

See Table 1 in this document and refer to the appropriate sprinkler technical data page for available temperatures and finishes.
 For Upright Intermediate Level installation, See NOTE below.

NOTE: When Upright XT1 Sprinklers listed on the chart below are equipped with the XG Guard and XWU Water Shield they can be used in intermediate level installation.

Sprinkler Base Part No. ¹	SIN	Sprinkler Style	Thread Size		Orifice Size	Nominal K-Factor		Maximum Pressure	Overall Length (Sprinkler)		Listings and Approvals ³	
			NPT	BSPT		U.S.	metric ²		Inches	mm	cULus ⁴	FM ⁵
Standard Response, Glass Bulb Type												
19914	VK1001	Upright	1/2"	--	Standard	5.6	80.6	175 psi	1-5/16	49	✓	✓
19926	VK1001	Upright	--	15 mm	Standard	5.6	80.6	175 psi	1-5/16	49	✓	✓
23098	VK1001	Upright	1/2"	--	Standard	5.6	80.6	UL-250 psi / FM-175 psi	1-5/16	49	✓	✓
19922	VK2001	Upright	3/4"	--	Large	8.0	115.2	175 psi	2	51	✓	✓
19934	VK2001	Upright	--	20 mm	Large	8.0	115.2	175 psi	2	51	✓	✓
19918 ⁶	VK2002	Upright	1/2"	--	Large	8.0	115.2	175 psi	1-5/16	49	✓	✓
19930	VK2002	Upright	--	15 mm	Large	8.0	115.2	175 psi	1-5/16	49	✓	✓
Quick Response, Glass Bulb Type												
19916	VK3001	Upright	1/2"	--	Standard	5.6	80.6	175 psi	1-5/16	49	✓	✓
19928	VK3001	Upright	--	15 mm	Standard	5.6	80.6	175 psi	1-5/16	49	✓	✓
23100	VK3001	Upright	1/2"	--	Standard	5.6	80.6	UL-250 psi / FM-175 psi	1-5/16	49	✓	✓
19924	VK3501	Upright	3/4"	--	Large	8.0	115.2	175 psi	2	51	✓	✓
19936	VK3501	Upright	--	20 mm	Large	8.0	115.2	175 psi	2	51	✓	✓
19920 ⁶	VK3502	Upright	1/2"	--	Large	8.0	115.2	175 psi	1-5/16	49	✓	✓
19932	VK3502	Upright	--	15 mm	Large	8.0	115.2	175 psi	1-5/16	49	✓	✓

Approved Temperature Ratings and Finishes

Refer to the sprinkler technical data sheet.

Footnotes

1. Base part number is shown. For complete part number, refer to Viking's current price list.
2. Metric K-factor measurement shown is when pressure is measured in Bar. When pressure is measured in kPa, divide the metric K-factor shown by 10.0.
3. This chart shows the listings and approvals available at the time of printing. Other approvals may be in process. Check with the manufacturer for any additional approvals.
4. Listed by Underwriters Laboratories, Inc. for use in the U.S. and Canada.
5. FM Approved for protection of occupancies described in the FM Global Loss Prevention Data Sheets (including 2-0 and 8-9) and Technical Advisory Bulletins.
6. The 1/2" NPT Large Orifice Sprinkler is listed and approved for retrofit only when installed in accordance with NFPA 13.



TECHNICAL DATA

GUARDS AND WATER SHIELDS FOR XT1 SPRINKLERS

The Viking Corporation, 210 N Industrial Park Drive, Hastings MI 49058
 Telephone: 269-945-9501 Technical Services: 877-384-5464 Fax: 269-818-1680 Email: techsvcs@vikingcorp.com
 Visit the Viking website for the latest edition of this technical data page www.vikinggroupinc.com

Approval Chart 2

Pendent Intermediate Level XT1 Sprinklers

Pendent sprinklers, guards, and water shields must be ordered separately. Assembly is required. See Table 1 in this document and refer to the appropriate sprinkler technical data page for available temperatures and finishes.

Sprinkler Base Part No. ¹	SIN	Sprinkler Style	Thread Size		Orifice Size	Nominal K-Factor		Maximum Pressure	Overall Length (Sprinkler)		Listings and Approvals ³	
			NPT	BSPT		U.S.	metric ²		Inches	mm	cULus ⁴	FM ⁵
Standard Response, Glass Bulb Type												
19915	VK1021	Pendent	1/2"	--	Standard	5.6	80.6	175 psi	1-5/16	49	✓	✓
19927	VK1021	Pendent	--	15 mm	Standard	5.6	80.6	175 psi	1-5/16	49	✓	✓
23099	VK1021	Pendent	1/2"	--	Standard	5.6	80.6	UL-250 psi / FM-175 psi	1-5/16	49	✓	✓
19923	VK2021	Pendent	3/4"	--	Large	8.0	115.2	175 psi	2	51	✓	✓
19935	VK2021	Pendent	--	20 mm	Large	8.0	115.2	175 psi	2	51	✓	✓
19919 ⁶	VK2022	Pendent	1/2"	--	Large	8.0	115.2	175 psi	1-5/16	49	✓	✓
19931	VK2022	Pendent	--	15 mm	Large	8.0	115.2	175 psi	1-5/16	49	✓	✓
Quick Response, Glass Bulb Type												
19917	VK3021	Pendent	1/2"	--	Standard	5.6	80.6	175 psi	1-5/16	49	✓	✓
19929	VK3021	Pendent	--	15 mm	Standard	5.6	80.6	175 psi	1-5/16	49	✓	✓
23101	VK3021	Pendent	--	15 mm	Standard	5.6	80.6	UL-250 psi / FM-175 psi	1-5/16	49	✓	✓
19925	VK3521	Pendent	3/4"	--	Large	8.0	115.2	175 psi	2	51	✓	✓
19937	VK3521	Pendent	--	20 mm	Large	8.0	115.2	175 psi	2	51	✓	✓
19921 ⁶	VK3522	Pendent	1/2"	--	Large	8.0	115.2	175 psi	1-5/16	49	✓	✓
19933	VK3522	Pendent	--	15 mm	Large	8.0	115.2	175 psi	1-5/16	49	✓	✓

Approved Temperature Ratings and Finishes

Refer to the sprinkler technical data sheet.

Footnotes

- Base part number is shown. For complete part number, refer to Viking's current price list.
- Metric K-factor measurement shown is when pressure is measured in Bar. When pressure is measured in kPa, divide the metric K-factor shown by 10.0.
- This chart shows the listings and approvals available at the time of printing. Other approvals may be in process. Check with the manufacturer for any additional approvals.
- Listed by Underwriters Laboratories, Inc. for use in the U.S. and Canada.
- FM Approved for protection of occupancies described in the FM Global Loss Prevention Data Sheets (including 2-0 and 8-9) and Technical Advisory Bulletins.
- The 1/2" NPT Large Orifice Sprinkler is listed and approved for retrofit only when installed in accordance with NFPA 13.