



TECHNICAL DATA

PRESSURE OPERATED RELIEF VALVE (PORV) MODEL C-1

1. DESCRIPTION

The Viking Model C-1 Pressure Operated Relief Valve (PORV) is used in Viking Deluge Systems when automatically resetting releases are used. Once tripped, it maintains a positive vent to prevent the deluge valve from automatically resetting prematurely. The device is automatically reset when the pressure is removed from the control diaphragm. The device is designed to trip when approximately 5 psi (.3 bar) of pressure is applied to the control diaphragm. The trip point is non-adjustable.

The PORV may also be used to trip the deluge valve by applying air or water pressure to the PORV control diaphragm.



2. LISTINGS AND APPROVALS

For 250 PSI (17.2 bar) Water Working Pressure:

cULus Listed - VLTR

FM Approved - Deluge Sprinkler Systems, Preaction Sprinkler Systems

VdS - G4920053, G4920054, G4920055, & G4920056

For 175 PSI (12.1 bar) Water Working Pressure:

L.P.C. (F.O.C.) Approved



WARNING: Cancer and Reproductive Harm-
www.P65Warnings.ca.gov

3. TECHNICAL DATA

Specifications:

Materials:

Body: Brass Cast UNS-C84400

Diaphragm Assembly: Neoprene ASTM D 2000

Spring: Stainless Steel UNS-S30200

Seat: Brass Bar UNS-C36000

Operation Pressure: 5 to 7 psi (.3 to .5 bar) when pressure is supplied from the system side of the deluge valve.

Ordering Information:

Part Number: 01936C

Shipping weight: 8 lbs.

Available Since 1989.

Scan with smart phone to access
technical and troubleshooting resources.



4. INSTALLATION

DO NOT plug the 1/4" (8 mm) drain port or the 1/2" (15 mm) outlet marked "To Open Drain". Pipe drain outlets to open atmospheric drain. DO NOT connect drain outlets to any line that may be pressurized, as this may create back pressure on the Pressure Operated Relief Valve. DO NOT subject the PORV to the sprinkler system hydrostatic pressure test.

5. OPERATION

The inlet side of the PORV is connected directly to the top chamber of the deluge valve. In the set position, pressure is supplied through the orifice to both sides of the clapper diaphragm, which is held closed because of the area differential. When the deluge valve is tripped, pressurized water from the system side of the deluge valve depresses the control diaphragm of the PORV. The control diaphragm presses on a Schrader valve, allowing the pressurized water normally trapped above the clapper diaphragm to escape. When the pressure has escaped, the clapper rises and allows the constant flow of water from the top chamber of the deluge valve to flow through the PORV to the drain. If a release resets, the deluge valve will continue to operate until manually reset.

6. INSPECTIONS, TESTS AND MAINTENANCE

The Viking Pressure Operated Relief Valve should be tested for operation annually. Where difficulty in performance is experienced, the valve manufacturer or his authorized representative shall be contacted if any field adjustment is to be made.

A. TEST:

Trip the deluge system at 5 to 7 psi (.3 to .5 bar) system pressure. Water should flow from the 1/4" (8 mm) drain port located in the middle of the PORV. When water flows from the 1/4" (8 mm) drain port, the PORV should trip and discharge water from the 1/2" (15 mm) drain outlet.

B. DISASSEMBLY AND REPLACEMENT PARTS: (Refer to Figure 1)

1. Place the deluge system and the release system out of service.
2. Remove the PORV from the deluge valve trim.
3. Unscrew and separate the cover (6) and body (1) assembly from the end cover (8) and base (7) assembly using a pipe wrench.



TECHNICAL DATA

PRESSURE OPERATED RELIEF VALVE (PORV) MODEL C-1

4. Once the two assemblies are separated, the spring (6) can now be removed and Schrader valve assembly (11) can now be seen.
5. To replace the Schrader valve assembly (11), use a Socket wrench with a 7/16" socket.
6. To replace the diaphragm (9), the end cover (8) and base (7) will need to be separated by removing the screws (5) using a Phillips head screw driver.
7. To remove or replace any other parts, the cover (6) will need to be separated from the body (1) by removing the screws (5) with a Phillips head screw driver.
8. With the cover (6) separated from the body (1), this will allow for removal of the clapper spring (12), diaphragm assembly (3), and seal ring (4).
9. The seat (2) can be removed from the body (1) using a Socket wrench with a 7/8" socket.
10. Test operation of device after reassembly. See annual test procedure.

7. AVAILABILITY AND SERVICE

The Viking PORV is available through a network of Domestic, Canadian, and International Distributors. See the Viking Corp. Web site for closest distributor or contact The Viking Corporation.

8. GUARANTEES

For details of warranty, refer to Viking's current list price schedule or contact Viking directly.

ITEM NO.	PART NUMBER	DESCRIPTION	MATERIAL	NO. REQ'D.
1	--	Body	Brass	1
2	01468A	Seat	Brass	1
3	*	Diaphragm Assembly	Various	1
4	01604A	Seal Ring	Nylon Reinforced Neoprene	1
5	04505A	Screw, R.H., #10-24 x 5/8 (15,9 mm)	Stainless Steel	12
6	--	Cover	Brass	1
7	--	Base	Brass	1
8	--	End Cover	Brass	1
9	01792A	Diaphragm	Neoprene	1
10	04137A	Spring	Stainless Steel	1
11	06418A	Schrader Valve Assembly†	Brass and Stainless Steel	1
12	06177A	Clapper Spring	Stainless Steel	1
--Indicates replacement part not available.				
* Indicates replacement part only available in a Sub-Assembly listed below.				
† Schrader Valve Assembly replacement not available for the Model C-1 PORV manufactured prior to 1989.				
SUB-ASSEMBLY				
3-5, 9-12	12611	Maintenance Kit†		

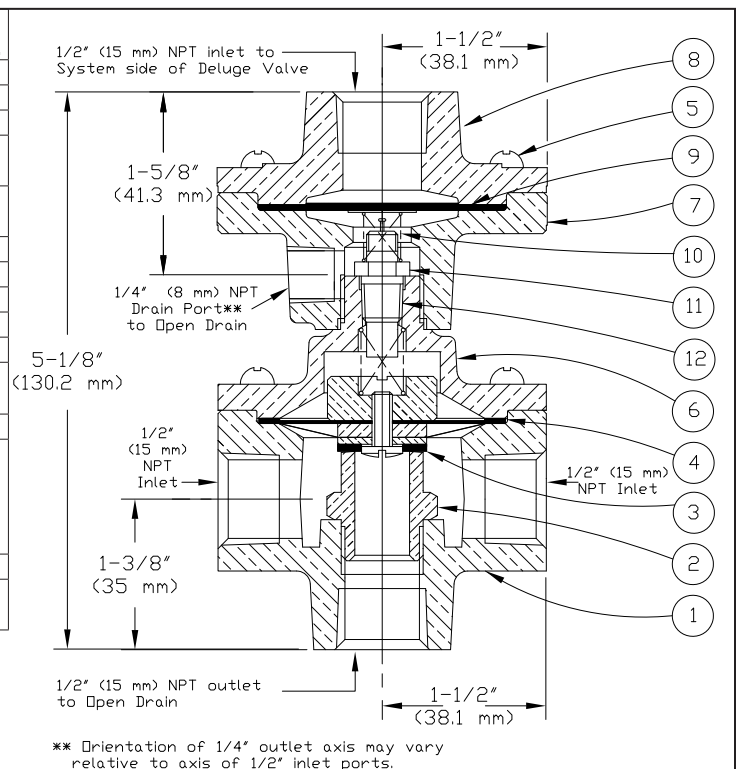

Figure 1 - Replacement Parts