



TECHNICAL DATA

MODEL E-1 DELUGE VALVE ANGLE STYLE 3" (DN80), 4" (DN100) & 6" (DN150)

The Viking Corporation, 210 N Industrial Park Drive, Hastings MI 49058

Telephone: 269-945-9501 Technical Services: 877-384-5464 Fax: 269-818-1680 Email: techsvcs@vikingcorp.com

Visit the Viking website for the latest edition of this technical data page: www.vikinggroupinc.com

1. DESCRIPTION

The Viking Model E-1 Deluge Valve is a quick-opening, differential diaphragm, flood valve with one moving mechanism.

The deluge valve is used to control water flow in deluge and preaction sprinkler systems. The valve is held closed by system water pressure trapped in the priming chamber, keeping the outlet chamber and system piping dry. In fire conditions, when the releasing system operates, pressure is released from the priming chamber. The deluge valve clapper opens to allow water to flow into the system piping.

Features

1. Field replaceable Diaphragm and Seat Rubbers.
2. Designed for installation in any position.
3. Designed to be reset without opening the valve.
4. Compatible with hydraulic, pneumatic, and/or electric release systems.

2. LISTINGS AND APPROVALS

For 250 PSI (17.2 bar) WWP

U.L. Listed: Guide No. VLFT & VLJH

C-UL Listed: Guide No. VLFT7

FM Approved: Deluge Sprinkler Systems, Preaction Sprinkler Systems, Refrigerated Area Sprinkler Systems

American Bureau of Shipping (ABS): Certificate No. 03-HS405911B-2-PDA

For 175 PSI (12.1 bar) WWP

New York City Board of Standard and Appeals: Calendar Number 219-76-SA

LPCB

VdS: G 4920053

CE: Pressure Equipment Directive 97/23/EC



WARNING: Cancer and Reproductive Harm-
www.P65Warnings.ca.gov

3. TECHNICAL DATA

Specifications

Maximum Working Water Pressure: 250 PSI (17.2 bar)

90 Degree Pattern (inlet to outlet)

Connections: See Table 1

Factory tested to 500 psi (34.5 bar)

Valve differential: over 2:1 (priming chamber to inlet chamber)

Priming chamber supply restriction (required): 0.0625" (1.6 mm)

Color of Valve: Red

Cv Factor: Refer to Table 1.

Friction loss: Refer to Table 1.

Material Standards:

Refer to Figure 2.

Ordering Information:

Part Numbers: Refer to Table 1.

Shipping Weight: Refer to Table 1.

3" (DN80) Available since 1985

4" (DN100) Available since 1985

6" (DN150) Available since 1984

Accessories:

Refer to Current Viking Price List for Part Numbers.

1. A Conventional Trim package for use with the Model E-1 Deluge Valve. The trim package includes the VALVE ACCESSORY PACKAGE and the fittings and nipples shown on the Viking Deluge Valve Conventional Trim Chart for the valve used. Trim Charts are provided in trim packages and on the Viking website. For optional factory assembled "modular" trim packages, refer to the Viking list price schedule or contact the manufacturer.
2. A Deluge Valve ACCESSORY PACKAGE includes required trim components. This package is needed when Viking Trim Packages are not used.
3. Auxiliary components are required for specific valve functions. For complete operating trim requirements refer to system data for



TECHNICAL DATA

MODEL E-1 DELUGE VALVE ANGLE STYLE 3" (DN80), 4" (DN100) & 6" (DN150)

The Viking Corporation, 210 N Industrial Park Drive, Hastings MI 49058

Telephone: 269-945-9501 Technical Services: 877-384-5464 Fax: 269-818-1680 Email: techsvcs@vikingcorp.com

Visit the Viking website for the latest edition of this technical data page: www.vikinggroupinc.com

DESCRIPTION	Nominal Size	Part Number	Friction Loss*	Cv Factor	Shipping Weight	
Flange/Flange <u>Flange Drilling</u>	ANSI ¹	3"	05912C	29 ft. (8.8 m)	187	73 lbs. (33 kg)
	ANSI ¹	4"	05909C	35 ft. (10.7 m)	470	123 lbs (56 kg)
	ANSI ¹	6"	05906C	33 ft. (10.1 m)	1088	251 lbs. (114 kg)
	ANSI/Japan ¹	6"	07136	33 ft. (10.1 m)	1088	251 lbs. (114 kg)
	PN10/16	DN80	08626	29 ft. (8.8 m)	187	73 lbs. (33 kg)
	PN10/16	DN100	08629	35 ft. (10.7 m)	470	123 lbs (56 kg)
	PN10/16	DN150	08631	33 ft. (10.1 m)	1088	236 lbs. (107 kg)
Flange/Groove <u>Flange Drilling / Pipe O.D.</u>	ANSI / 89 mm ¹	3"	05835C	29 ft. (8.8 m)	187	66lbs. (30 kg)
	ANSI / 114 mm ¹	4"	05839C	35 ft. (10.7 m)	470	112 lbs (51 kg)
	ANSI / 168 mm ¹	6"	05456C	33 ft. (10.1 m)	1088	236 lbs. (107 kg)
	PN10/16 / 89 mm	DN80	09539	29 ft. (8.8 m)	187	66lbs. (30 kg)
	PN10/16 / 114 mm	DN100	09540	35 ft. (10.7 m)	470	112 lbs (51 kg)
	PN10/16 / 168 mm	DN150	05456C	33 ft. (10.1 m)	1088	236 lbs. (107 kg)

Q= Flow
Cv= Flow Factor (GPM/1 PSI ΔP)
ΔP= Pressure Loss through Valve
S= Specific Gravity of Fluid

$$Q = Cv \sqrt{\frac{\Delta P}{S}}$$

* Expressed in equivalent length of pipe based on Hazen & Williams Formula C=120.

¹ Valves marked with ANSI for drilling patterns indicate ANSI B16.42 Class 150. Systems with water working pressures above 175 PSI (12 bar) may require extra-heavy pattern fittings. ANSI B16.42 Class 150 flanges are NOT compatible with ANSI Class 250 or Class 300 flanges. To mate the Model E-1 Deluge Valve with ANSI Class 250 or Class 300 flanges, use listed flange adapters of the appropriate pressure rating. For piping with grooved connections, the valve may be installed with listed grooved couplings of the appropriate pressure rating.

**Table 1 - Valve
Part Numbers and
Specifications**

the system used. System data is provided on the Viking website.

Additional accessories are available and may be required for system operation or supervision. Refer to the system description and technical data for complete operating trim requirements for the system used.

4. INSTALLATION (Refer to Figure 1 for identification of trim components)

A. General Instruction

1. Viking 3" (DN80), 4" (DN100), and 6" (DN150) Deluge Valves may be installed in any position.
 - a. Minor modification to trim may be required to facilitate drainage from the outlet chamber of the deluge valve (consult manufacturer).
 - b. Certain trim devices may require the valve to be installed vertically. (Refer to system data for the system used.)
1. The valve must be installed in an area not subject to freezing temperatures or physical damage.
2. The valve must be trimmed according to current Viking Trim Charts and appropriate instructions for the system used. Trim Charts can be found on the Viking Website.
 - a. Remove all plastic thread protectors from the openings of the deluge valve.
 - b. Apply a small amount of pipe-joint compound or tape to the external threads of all pipe connections required. Take care not to allow any compound, tape, or other foreign matter inside any of the nipples or openings of the valve or trim components.
 - c. Viking Model E Deluge Valve conventional trim charts are provided with Trim Packages and on the Viking website.
 - d. Verify that all system components are rated for the water working pressure of the system.

Hydrostatic Test:

The Model E-1 Deluge Valve is manufactured and listed for use at a maximum Water Working Pressure of 250 PSI (17.2 bar). The valve is factory tested at 500 PSI (34.5 bar). Model E-1 Deluge Valves may be hydrostatically tested at 300 PSI (20.7 bar) and/or 50 PSI (3.4 bar) above the normal Water Working Pressure, for limited periods of time (two hours) for the purpose of acceptance by the Authority Having Jurisdiction. If air testing is required, do not exceed 40 PSI (2.8 bar) air pressure.

NOTE: NEVER CONDUCT THE HYDROSTATIC TEST AGAINST THE PRESSURE OPERATED RELIEF VALVE. (PORV) TEMPORARILY REMOVE THE PORV FROM THE TRIM AND PLUG TRIM OPENINGS WHILE CONDUCTING THE HYDROSTATIC TEST.



TECHNICAL DATA

MODEL E-1 DELUGE VALVE ANGLE STYLE 3" (DN80), 4" (DN100) & 6" (DN150)

The Viking Corporation, 210 N Industrial Park Drive, Hastings MI 49058

Telephone: 269-945-9501 Technical Services: 877-384-5464 Fax: 269-818-1680 Email: techsvcs@vikingcorp.com

Visit the Viking website for the latest edition of this technical data page: www.vikinggroupinc.com

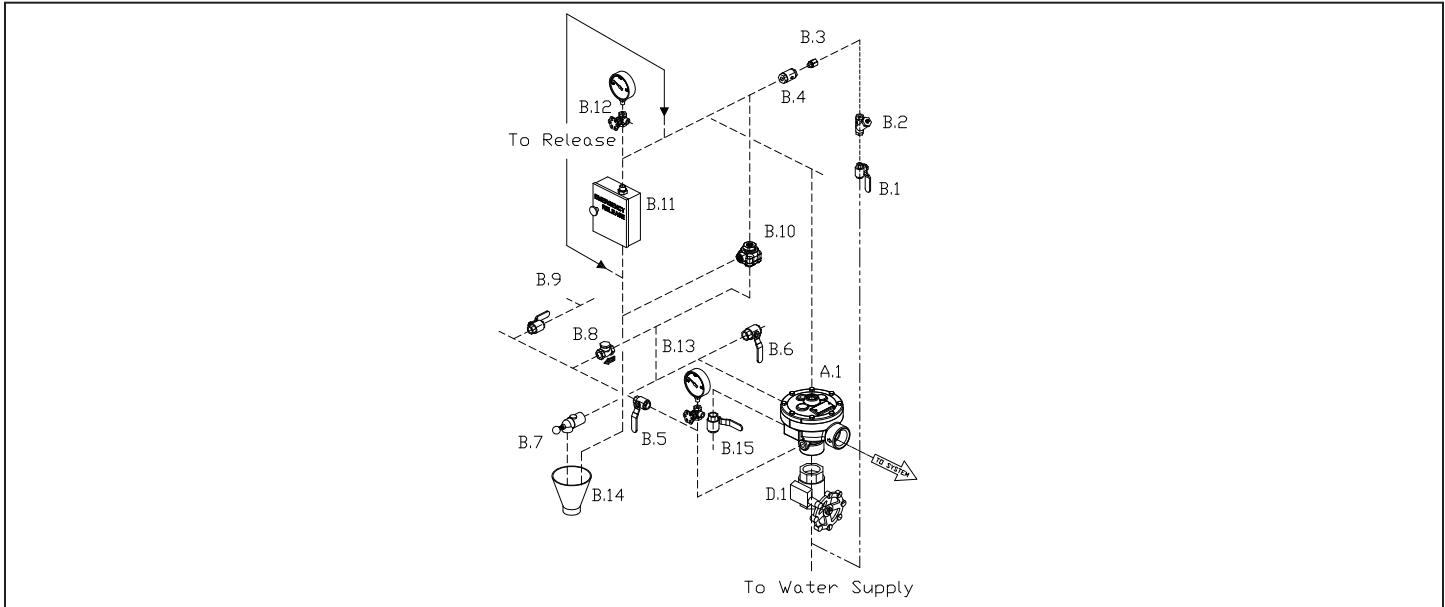

----- Dashed lines indicate nipples and fittings included with trim.

----- Phantom lines indicate piping required, but not included with trim.

Figure 1 - Trim Components

A.1	Deluge Valve	B.9	Alarm Shut Off Valve (Normally Open)
B.1	Priming Valve (Normally Open)	B.10	Pressure Operated Relief Valve (PORV)
B.2	Strainer	B.11	Emergency Release
B.3	1/16" Restricted Orifice	B.12	Priming Pressure Water Gauge and Valve
B.4	Spring Loaded Check Valve	B.13	Water Supply Pressure Water Gauge and Valve
B.5	Alarm Test Valve (Normally Closed)	B.14	Drain Cup
B.6	Auxiliary Drain Valve (Normally Closed)	B.15	Flow Test Valve (Normally Closed)
B.7	Drip Check Valve	D.1	Water Supply Control Valve
B.8	Drain Check Valve		

TRIM NOTE: (REFER ALSO TO SYSTEM DATA AND/OR TRIM CHART) DISCHARGE PIPING FROM THE AUXILIARY DRAIN VALVE, THE FLOW TEST VALVE, AND ALL SYSTEM DRAINS SHOULD BE KEPT SEPARATE. DO NOT CONNECT THE OUTLET OF THE DRIP CHECK TO ANY OTHER DRAIN. EXCEPTION: VIKING TOTALPAC SYSTEMS ARE MANUFACTURED WITH A SPECIFIC ARRANGEMENT OF INTERCONNECTED DRAIN PIPING TESTED AT THE FACTORY.

4. The priming line must be connected upstream of the system water supply main control valve or to a constant source of water at a pressure equal to the system water supply.
5. After the deluge valve is set, operation of the deluge valve requires the release of priming water from the priming chamber. This may be by automatic or manual operation of the release system. Viking Deluge valves are compatible with hydraulic, pneumatic, and electric release systems. For specific trim arrangements, refer to Trim Charts and System Data describing the system being installed. Trim Charts are available on the Viking website and are provided with trim packages. System Data sheets are available on the Viking website.
 - a. Hydraulic Release Systems - See Graphs A through C for the maximum allowable elevation of hydraulic release piping above the deluge valve. If the maximum height of hydraulic release piping exceeds the limit shown in Graph A, B, or C for the valve used, use a pneumatic or electric release system.



TECHNICAL DATA

MODEL E-1 DELUGE VALVE ANGLE STYLE 3" (DN80), 4" (DN100) & 6" (DN150)

The Viking Corporation, 210 N Industrial Park Drive, Hastings MI 49058

Telephone: 269-945-9501 Technical Services: 877-384-5464 Fax: 269-818-1680 Email: techsvcs@vikingcorp.com

Visit the Viking website for the latest edition of this technical data page: www.vikinggroupinc.com

- b. Pneumatic Release Systems - A Viking Pneumatic Actuator is required between the release system connection provided on deluge valve trim and pneumatic release system piping.
- c. Electric Release Systems - Solenoid Valves, System Control Panels, and Electrical Detectors must be compatible. Consult appropriate listing and/or approval guides.

NOTE: FOR OPERATION AT WATER PRESSURES IN EXCESS OF 175 PSI, A 250 PSI RATED SOLENOID VALVE MUST BE USED. REFER TO APPROPRIATE VIKING TECHNICAL DATA PAGE FOR TYPE OF SYSTEM USED.

▲ CAUTION

Operation of Viking Deluge Valves by pressurizing the priming chamber with air pressure or any other pressurized gas is not recommended or approved.

B. Placing the Valve in Service (Refer to Figure 1 and/or appropriate Trim Charts and System Data for the system used)

For deluge valves equipped with Conventional Deluge Valve Trim follow steps 1 through 10 (and 11 & 12 if applicable) below.

1. Verify:
 - a. The system Main Water Supply Control Valve (D.1) is closed and the deluge valve is trimmed according to current Viking Trim Charts and schematic drawings for the system used.
 - b. The system has been properly drained.
 - c. Auxiliary Drain (B.6) is open.
 - d. The Emergency Release (B.11) is closed.
 - e. The system water supply piping is pressurized up to the closed Main Water Supply Control Valve (D.1) and the priming line is pressurized up to the closed Priming Valve (B.1).
2. For Systems equipped with:
 - a. Hydraulic Release Systems:
 - i. Verify that all releasing devices are set and that any Inspector's Test Valve and/or auxiliary drain valves are closed.
 - ii. Open Priming Valve (B.1). Allow the hydraulic release system to fill. When priming pressure gauge (B.12) indicates that the release piping and priming chamber pressure is equal to system supply pressure, proceed to Step 3.
 - b. Pneumatic Release Systems:

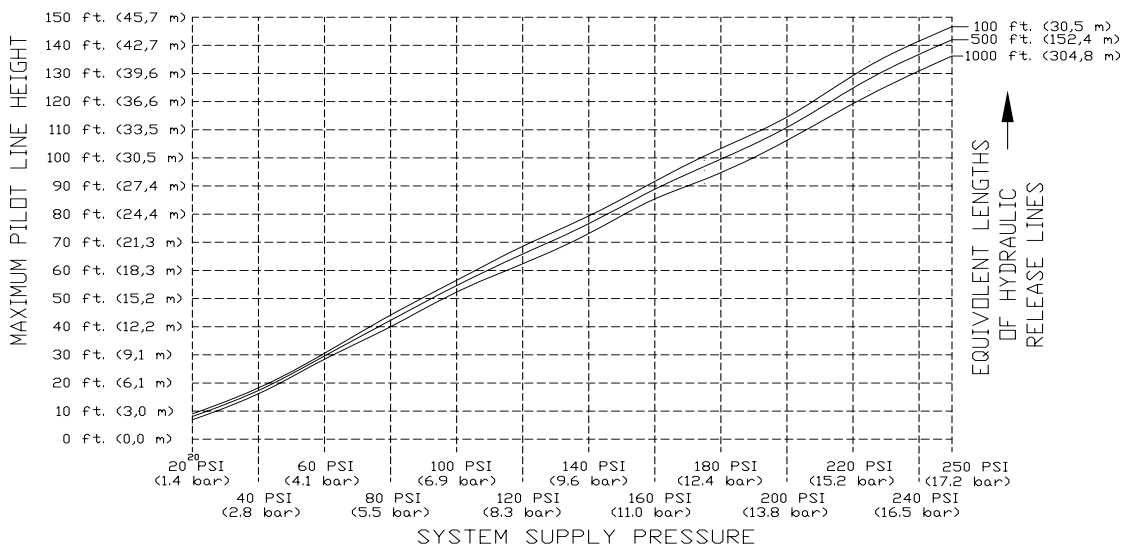

Graph A

Maximum Allowable Pilot Heights for Select Equivalent Lengths of Hydraulic Release Piping For 3" (DN80) Model E-1 Deluge Valves with 1/16" (1.6 mm) Restricted Orifice

Graph is based on 1/2" (15 mm) pilot sprinklers installed on 1/2" (15 mm) Schedule 40 galvanized release piping.

If the maximum height of hydraulic release piping exceeds the limits shown on the graph, use pneumatic or electric release system.



TECHNICAL DATA

**MODEL E-1 DELUGE VALVE
ANGLE STYLE
3" (DN80), 4" (DN100) & 6" (DN150)**

The Viking Corporation, 210 N Industrial Park Drive, Hastings MI 49058
 Telephone: 269-945-9501 Technical Services: 877-384-5464 Fax: 269-818-1680 Email: techsvcs@vikingcorp.com
 Visit the Viking website for the latest edition of this technical data page: www.vikinggroupinc.com

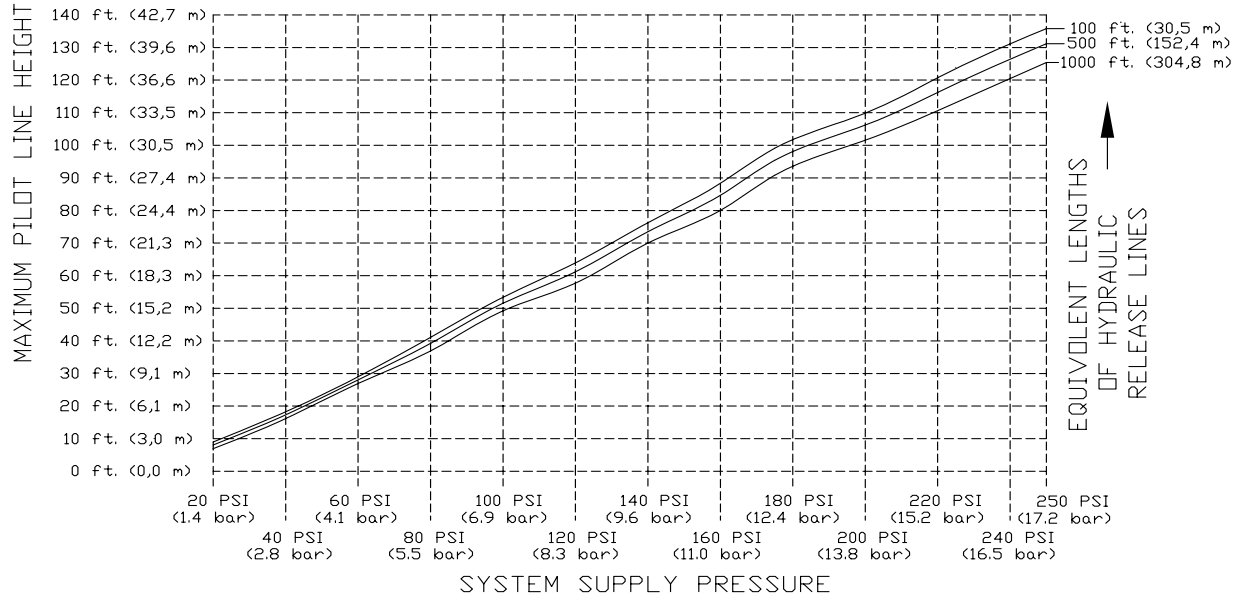

Graph B
Maximum Allowable Pilot Heights for Select Equivalent Lengths of Hydraulic Release Piping For 4" (DN100) Model E-1 Deluge Valves with 1/16" (1.6 mm) Restricted Orifice

Graph is based on 1/2" (15 mm) pilot sprinklers installed on 1/2" (15 mm) Schedule 40 galvanized release piping. If the maximum height of hydraulic release piping exceeds the limits shown on the graph, use pneumatic or electric release system.

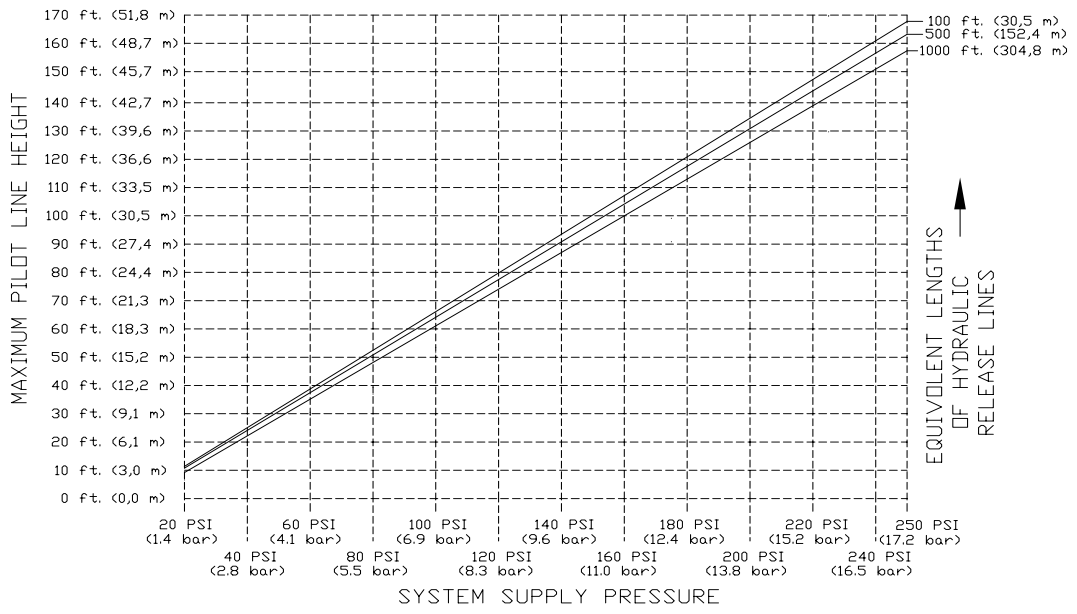

Graph C
Maximum Allowable Pilot Heights for Select Equivalent Lengths of Hydraulic Release Piping For 6" (DN150) Model E-1 Deluge Valves with 1/16" (1.6 mm) Restricted Orifice

Graph is based on 1/2" (15 mm) pilot sprinklers installed on 1/2" (15 mm) Schedule 40 galvanized release piping. If the maximum height of hydraulic release piping exceeds the limits shown on the graph, use pneumatic or electric release system.



TECHNICAL DATA

**MODEL E-1 DELUGE VALVE
ANGLE STYLE**
3" (DN80), 4" (DN100) & 6" (DN150)

The Viking Corporation, 210 N Industrial Park Drive, Hastings MI 49058

Telephone: 269-945-9501 Technical Services: 877-384-5464 Fax: 269-818-1680 Email: techsvcs@vikingcorp.com

Visit the Viking website for the latest edition of this technical data page: www.vikinggroupinc.com

- i. Set the release system.
- ii. Open Priming Valve (B.1).
- iii. Proceed to step 3.
- c. Electric Release Systems:
 - i. Open Priming Valve (B.1).
 - ii. Set the electric release system.
 - iii. Proceed to step 3.
3. Open Flow Test Valve (B.15).
4. Partially open Main Water Supply Control Valve (D.1).
5. When full flow develops from the Flow Test Valve (B.15), close the Flow Test Valve (B.15). Verify that there is no flow from the open auxiliary drain (B.6).
6. Close auxiliary drain (B.6).
7. Fully open and secure the Main Water Supply Control Valve (D.1).
8. Verify that the Alarm Shut-off Valve (B.9) is open and that all other valves are in their normal** operating position.
9. Depress the plunger of Drip Check (B.7). No water should flow from the Drip Check (B.7) when the plunger is pushed.
10. Check for and repair all leaks.
11. On new installations, those systems that have been placed out of service or where new equipment has been installed, trip test the system to verify that all equipment functions properly. Refer to paragraph 6.2.B: ANNUAL TRIP TEST instructions.

⚠ CAUTION

Performing a trip test results in operation of the Deluge Valve. Water will flow into the sprinkler piping. Take necessary precautions to prevent damage.

12. After completing a trip test, perform SEMI-ANNUAL maintenance.

** For normal operating position, refer to Figure 1 and/or Trim Charts and System Data for the system used.

C. Valve Removed From Service

NOTE: WHEN A VALVE HAS BEEN REMOVED FROM SERVICE AND IS SUBJECT TO FREEZING OR WILL BE OUT OF SERVICE FOR AN EXTENDED PERIOD OF TIME, ALL WATER MUST BE REMOVED FROM THE PRIMING CHAMBER, TRIM PIPING, WATER SUPPLY PIPING, AND OTHER TRAPPED AREAS.

5. OPERATION (Refer to Figure 2.)

The Viking Model E-1 Deluge Valve has an inlet chamber, an outlet chamber, and a priming chamber. The inlet chamber and outlet chamber are separated from the priming chamber by the clapper (6) and diaphragm rubber (2).

In the set condition:

System pressure is supplied to the priming chamber through a restricted priming line (trim) equipped with a check valve. System water supply pressure trapped in the priming chamber holds the clapper (6) on seat (9) due to area differential design. Clapper (6) separates the inlet chamber from the outlet chamber, keeping the outlet chamber and system piping dry.

In fire conditions:

When the release system operates, pressure is released from the priming chamber faster than it is supplied through the restricted priming line. Water supply pressure in the inlet chamber, forces the clapper (6) off from seat (9), allowing water to flow through the outlet and into the system and alarm devices.

For Deluge Valves equipped with Conventional Trim: (Refer to Figure 1.)

When the deluge valve operates, the sensing end of the PORV (B.10) is pressurized, causing the PORV (B.10) to operate. When the PORV (B.10) operates, it continually vents the priming chamber to prevent the deluge valve from resetting even if the open releasing devices close. The deluge valve can only be reset after the system is taken out of service, and the outlet chamber of the deluge valve and associated trim piping is depressurized and drained.



TECHNICAL DATA

**MODEL E-1 DELUGE VALVE
ANGLE STYLE**
3" (DN80), 4" (DN100) & 6" (DN150)

The Viking Corporation, 210 N Industrial Park Drive, Hastings MI 49058

Telephone: 269-945-9501 Technical Services: 877-384-5464 Fax: 269-818-1680 Email: techsvcs@vikingcorp.com

Visit the Viking website for the latest edition of this technical data page: www.vikinggroupinc.com

6. INSPECTIONS, TESTS, AND MAINTENANCE (Refer to Figure 1 for identification of trim components.)

I. Inspection

It is imperative that the system be inspected and tested on a regular basis. The frequency of the inspections may vary due to contaminated water supplies, corrosive water supplies, or corrosive atmospheres. Also, the alarm devices, detection systems, or other connected trim may require a more frequent schedule. For minimum maintenance and inspection requirements, refer to NFPA 25. In addition, the Authority Having Jurisdiction may have additional maintenance, testing, and inspection requirements that must be followed. The following recommendations are minimum requirements. (For additional information, refer to Viking Trim Charts and System Data describing systems with the release system used.)

A. Weekly:

Weekly visual inspection of the Viking Deluge Valve is recommended.

1. Verify that the Main Water Supply Control Valve (D.1) is open and that all other valves are in their normal** operating position and appropriately secured.
2. Check for signs of mechanical damage, leakage, and/or corrosive activity. If detected, perform maintenance as required. If necessary, replace the device.
3. Verify that the valve and trim are adequately heated and protected from freezing and physical damage.

** For normal operating position, refer to Figure 1 and/or Trim Charts and System Data for the system used.

II. Tests

Quarterly testing of water flow alarms and performance of a Main Drain Test is recommended and may be required by the Authority Having Jurisdiction.

A. Quarterly Water Flow Alarm Test

1. Notify the Authority Having Jurisdiction and those in the area affected by the test.
2. To test the local electric alarm (if provided) and/or mechanical water motor alarm (if provided), OPEN the alarm test valve (B.5) in the deluge valve trim.
 - a. Electric alarm pressure switches (if provided) should activate.
 - b. Electric local alarms should be audible.
 - c. The local water motor gong should be audible.
 - d. If equipped with remote station alarm signaling devices, verify that alarm signals were received.
3. When testing is complete, CLOSE the alarm test valve (B.5).
4. Verify:
 - a. All local alarms stop sounding and alarm panels (if provided) reset.
 - b. All remote station alarms reset.
 - c. Supply piping to water motor alarm properly drains.
5. Verify that the Alarm Shut-off Valve (B.9) is OPEN, and the Alarm Test Valve (B.5) is CLOSED.
6. Verify that the outlet chamber is free of water. No water should flow from the Drip Check (B.7) when the plunger is pushed.
7. Notify the Authority Having Jurisdiction and those in the affected area that testing is complete.

B. Quarterly Main Drain Test

1. Notify the Authority Having Jurisdiction and those in the area affected by the test.
2. Record pressure reading from the water supply pressure gauge (B.13).
3. Verify that the outlet chamber of the deluge valve is free of water. No water should flow from the drip check (B.7) when the plunger is pushed.
4. Fully OPEN the flow test valve (B.15).
5. When a full flow is developed from the flow test valve (B.15), record the residual pressure from the water supply pressure gauge (B.13).
6. When the test is complete, SLOWLY CLOSE the flow test valve.
7. Compare test results with previous flow information. If deterioration of the water supply is detected, take appropriate steps to restore adequate water supply.
8. Verify:
 - a. Normal water supply pressure has been restored to the inlet chamber, the priming chamber, and the release system. The pressure on the priming chamber water pressure gauge should equal the system water supply pressure.
 - b. All alarm devices and valves are secured in normal** operating position.
9. Notify the Authority Having Jurisdiction that the test is complete. Record and/or provide notification of test results as required by the Authority Having Jurisdiction.

** For normal operating position, refer to Figure 1 and/or Trim Charts and System Data for the system used.



TECHNICAL DATA

**MODEL E-1 DELUGE VALVE
ANGLE STYLE**
3" (DN80), 4" (DN100) & 6" (DN150)

The Viking Corporation, 210 N Industrial Park Drive, Hastings MI 49058

Telephone: 269-945-9501 Technical Services: 877-384-5464 Fax: 269-818-1680 Email: techsvcs@vikingcorp.com

Visit the Viking website for the latest edition of this technical data page: www.vikinggroupinc.com

C. Annual Trip Test

▲ CAUTION

Performing a trip test results in operation of the Deluge Valve. Water will flow into the sprinkler piping. Take necessary precautions to prevent damage.

1. Notify the Authority Having Jurisdiction and those in the area affected by the test.
2. Fully open the flow test valve (B.15) to flush away any accumulation of foreign material.
3. Close the flow test valve (B.15).
4. Trip the system by operating the release system. Allow a full flow to pass through the deluge valve. Water flow alarms should operate.
5. When test is complete:
 - a. Close the Main Water Supply Control Valve (D.1).
 - b. Close the Priming Valve (B.1).
 - c. Open the Auxiliary Drain valve (B.6).
 - d. Open all system main drains and auxiliary drains. Allow the system to drain completely.
6. Perform SEMI-ANNUAL maintenance. Refer to paragraph 6.III.B.
7. Place the system in service. Refer to Item 4-B INSTALLATION: PLACING THE VALVE IN SERVICE.

NOTE: DELUGE VALVES SUPPLIED BY BRACKISH WATER, SALT WATER, FOAM, FOAM/WATER SOLUTION, OR ANY OTHER CORROSIVE WATER SUPPLY SHOULD BE FLUSHED WITH GOOD QUALITY FRESH WATER BEFORE BEING RETURNED TO SERVICE.

8. Notify the Authority Having Jurisdiction that the test is complete. Record and/or provide notification of test results as required by the Authority Having Jurisdiction.

III. Maintenance (Refer to Figures 1 and 2)

NOTICE

The owner is responsible for maintaining the fire protection system and devices in proper operating condition. The Deluge Valve must be kept from freezing conditions and physical damage that could impair its operation.

▲ WARNING

Any system maintenance which involves placing a control valve or detection system out of service may eliminate the Fire Protection capabilities of that system. Prior to proceeding, notify all Authorities Having Jurisdiction. Consideration should be given to employment of a Fire Patrol in the affected areas.

Where difficulty in performance is experienced, the valve manufacturer or his authorized representative shall be contacted if any field adjustment is to be made.

A. After Each Operation:

1. Sprinkler systems that have been subjected to a fire must be returned to service as soon as possible. The entire system must be inspected for damage, and repaired or replaced as necessary.
2. Deluge valves and trim that have been subjected to brackish water, salt water, foam, foam/water solution, or any other corrosive water supply should be flushed with good quality fresh water before being returned to service.
3. Perform SEMI-ANNUAL maintenance after every operation.

B. Semi-Annual Maintenance:

1. Remove the system from service. (Refer to Deluge or Preaction System Data that describes systems with the release system used for additional information.)
 - a. Close the Main Water Supply Control Valve (D.1) and Priming Valve (B.1).
 - b. Open the auxiliary drain Valve (B.6).
 - c. Relieve pressure in the priming chamber by opening the emergency release (B.11).
2. Inspect all trim for signs of corrosion and/or blockage. Clean and/or replace as required.
3. Clean and/or replace all strainer screens (including B.2).
4. Refer to Item 4-B, INSTALLATION: PLACING THE VALVE IN SERVICE.



TECHNICAL DATA

**MODEL E-1 DELUGE VALVE
ANGLE STYLE
3" (DN80), 4" (DN100) & 6" (DN150)**

The Viking Corporation, 210 N Industrial Park Drive, Hastings MI 49058

Telephone: 269-945-9501 Technical Services: 877-384-5464 Fax: 269-818-1680 Email: techsvcs@vikingcorp.com

Visit the Viking website for the latest edition of this technical data page: www.vikinggroupinc.com

C. Every Fifth Year

1. Internal inspection of deluge valves is recommended every five years unless inspections and tests indicate more frequent internal inspections are required. Refer to DISASSEMBLY instructions provided below.
2. Internal inspection of strainers and restricted orifices is recommended every five years unless inspections and tests indicate more frequent internal inspections are required.
3. Record and provide notification of inspection results as required by the Authority Having Jurisdiction.

D. Valve Disassembly (Refer to Figure 2.)

1. Remove the valve from service (see the release system description and Technical Data for additional information). Close the main control valve, open the main drain valve. Release the pressure in the priming chamber by opening the emergency release Valve.
2. Disconnect and remove necessary trim from the cover.
3. Remove the cover (3): Remove each of the cap screws (7).
 - a. For 3" and 4" valves, use Socket Wrench with a 3/4" socket.
 - b. For 6" valves, use a Socket Wrench with a 15/16" socket.
 - c. Lift the cover (3) off the valve body (1) and gently set it aside.

E. Installing Replacement Parts and Valve Reassembly (Refer to Figure 2.)

1. To replace the entire clapper assembly, which is ordered pre-assembled:
 - a. Remove the old clapper assembly (2, 4, 5, 6, 7, 8, and 10) by placing a flat head screwdriver between the body (1) and the diaphragm rubber and then lifting the clapper assembly from valve body (1).
 - b. Inspect the seat (9).

NOTE: Prior to reassembly, flush the valve of all foreign matter. The valve seat (9) must be clean and free from all marks and scratches.
c. Install the new clapper assembly kit (2, 4, 5, 6, 7, 8, and 10).

If the entire clapper assembly does not need to be replaced, each of the parts of the clapper assembly kit are offered individually for replacement.

2. To replace the clamp ring (4):
 - a. Remove each of the screws (5):
 - i. For 3" valves, use a Phillips head screwdriver.
 - ii. For 4" valves, use a Socket Wrench with a 1/2" socket.
 - iii. For 6" valves, use a Socket Wrench with a 9/16" socket.
 - b. Remove the existing clamp ring from the diaphragm rubber (2).

NOTE: When replacing the clamp ring (4) on the 3" size only, notice there is a groove in the seat of the clamp ring (4). This groove must be placed into the raised groove of the diaphragm rubber (2). On the 4" and 6" valves, the clamp ring (4) doesn't have a grooved seat; there is a rounded edge and there is a sharp edge on the clamp ring (4). When installing the clamp ring (4) on the 4" and 6" valves, the rounded edge of the clamp ring (4) needs to be facing down towards the clapper (6).

- c. When installing the new clamp ring (4), install the new screws (5) in a star-shaped pattern using the tools indicated in Step 2a above.
3. To replace the diaphragm rubber (2):
 - a. Remove the diaphragm rubber (2) by removing the clamp ring (4) as indicated in Step 2 above and then removing the diaphragm rubber (2) from the clapper assembly.

NOTE: In the 3" valve, the diaphragm rubber (2) has a raised groove, which fits into the grooved seat of the clamp ring (4). With the 4" and 6" valves, there is no grooved seat in the clamp ring (4) or a raised edge on the top of the diaphragm rubber (2). The raised edge on the diaphragm rubber (2) is on the bottom and it fits into the grooved seat of the clapper (6) itself.

- b. To install the new diaphragm rubber (2) on the 3" valve, simply fit it into the clapper (6). To install the new diaphragm rubber (2) on the 4" and 6" valves, install the groove of the diaphragm rubber (2) into the clapper (6) itself.

NOTE: PRIOR TO INSTALLING A NEW DIAPHRAGM RUBBER (2) OR SEAT RUBBER ASSEMBLY (8), MAKE CERTAIN THAT ALL SURFACES ARE CLEAN AND FREE OF FOREIGN MATTER. THE SEAT (9) MUST BE SMOOTH AND FREE OF NICKS, BURRS, OR INDENTATIONS.



TECHNICAL DATA

**MODEL E-1 DELUGE VALVE
ANGLE STYLE**
3" (DN80), 4" (DN100) & 6" (DN150)

The Viking Corporation, 210 N Industrial Park Drive, Hastings MI 49058

Telephone: 269-945-9501 Technical Services: 877-384-5464 Fax: 269-818-1680 Email: techsvcs@vikingcorp.com

Visit the Viking website for the latest edition of this technical data page: www.vikinggroupinc.com

4. To replace the seat rubber assembly (8):
 - a. Remove each of the screws (10).
 - i. For 3" valves, use a Phillips head screwdriver.
 - ii. For 4" valves, use a Socket Wrench with a 1/2" socket.
 - iii. For 6" valves, use a Socket Wrench with a 9/16" socket.
 - b. Remove the old seat rubber assembly (8) from the clapper (6).
 - c. Install the new seat rubber assembly (8).

NOTE: There is a raised edge on the rubber itself. Install with the raised edge facing down into the grooved seat of the clapper (6).

- d. Install the new screws (10) into the seat rubber assembly (8) in a star-shaped pattern using the wrenches indicated in Step 4a above.

5. To replace the clapper (6) itself:
 - a. First, remove the clamp ring (4), diaphragm rubber (2), and the seat rubber assembly (8) from the old clapper (6) as described in the previous steps and then install them onto the new clapper (6).
6. To re-install the cover (3), line up the holes and install the cap screws (7) into the cover (3) in a star-shaped pattern.
 - a. For 3" and 4" valves, use a Socket Wrench with a 3/4" socket.
 - b. For 6" valves, use a 15/16" Socket Wrench with a 15/16" socket.

7. AVAILABILITY

The Viking Model E-1 Deluge Valve is available through a network of domestic and international distributors. See the Viking Corp. Web site for closest distributor or contact The Viking Corporation.

8. GUARANTEES

For details of warranty, refer to Viking's current list price schedule or contact Viking directly.



TECHNICAL DATA

MODEL E-1 DELUGE VALVE ANGLE STYLE 3" (DN80), 4" (DN100) & 6" (DN150)

The Viking Corporation, 210 N Industrial Park Drive, Hastings MI 49058
 Telephone: 269-945-9501 Technical Services: 877-384-5464 Fax: 269-818-1680 Email: techsvcs@vikingcorp.com
 Visit the Viking website for the latest edition of this technical data page: www.vikinggroupinc.com

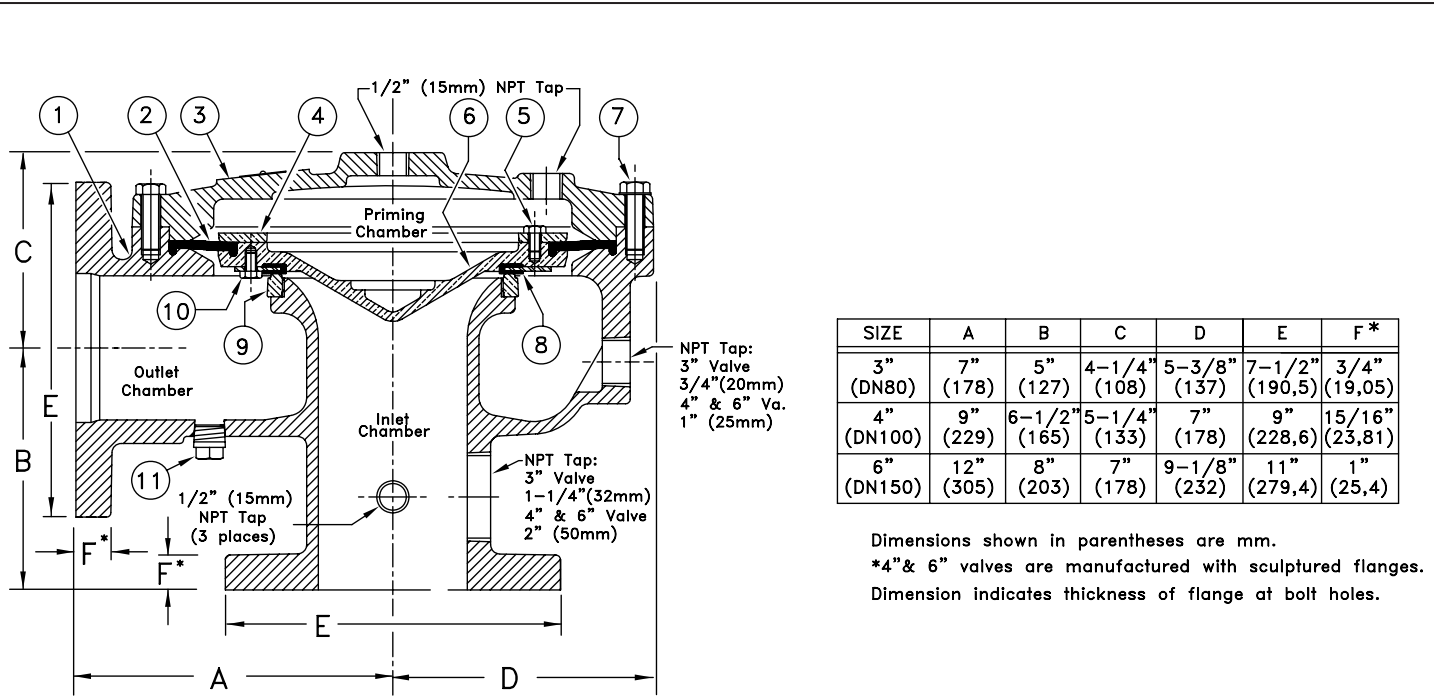

SIZE	A	B	C	D	E	F*
3" (DN80)	7" (178)	5" (127)	4-1/4" (108)	5-3/8" (137)	7-1/2" (190,5)	3/4" (19,05)
4" (DN100)	9" (229)	6-1/2" (165)	5-1/4" (133)	7" (178)	9" (228,6)	15/16" (23,81)
6" (DN150)	12" (305)	8" (203)	7" (178)	9-1/8" (232)	11" (279,4)	1" (25,4)

Dimensions shown in parentheses are mm.
 *4" & 6" valves are manufactured with sculptured flanges.
 Dimension indicates thickness of flange at bolt holes.

Figure 2: Replacement Parts

ITEM NO.	PART NUMBER			DESCRIPTION	MATERIAL	NO. REQ'D		
	3" (DN80)	4" (DN100)	6" (DN150)			3" (DN80)	4" (DN100)	6" (DN150)
1	--	--	--	Body	Ductile Iron 60-40-18 or 65-45-12	1	1	1
2	02492C	02377B	01974C	Diaphragm Rubber	EPDM, ASTM D2000	1	1	1
3	--	--	--	Cover	Ductile Iron 65-45-12	1	1	1
4	02493B	02378B	05704B	Clamp Ring	Brass UNS-C84400	1	1	1
5	02494A			Screw, R.H., No. 10-24 x 1/2" (12.7 mm) lg.	Stainless Steel UNS-S30200	6		
		02383A		Screw, H.H.C., 5/16" - 18 x 1/2" (12.7 mm) lg.	Stainless Steel UNS-S30400		8	
			02454A	Screw, H.H.C., 3/8"-16 x 5/8" (15.9 mm) lg.	Stainless Steel UNS-S30400			12
6	08846N	08844N	08570N	Clapper	Ductile Iron 65-45-12 Teflon® Coated	1	1	1
7	02169A			Screw, H.H.C., 1/2"-13 x 1-1/4" (31.8 mm) lg.	Steel	10		
		02200A		Screw, H.H.C., 1/2"-13 x 1-1/2" (38.1 mm) lg.	Steel		12	
			05707A	Screw, H.H.C., 5/8"-11 x 1-3/4" (44.5 mm) lg.	Steel			15
8	02497B	02382B	02176B	Seat Rubber Assembly	EPDM/Stainless Steel UNS-S30400	1	1	1
9	--	--	--	Seat	Brass UNS-C84400	1	1	1
10	02496A			Screw, R.H., 10-24 x 3/8" (9.5 mm) lg.	Stainless Steel UNS-S30200	6		
		08217		Screw, H.H.C., 5/16" - 18 x 1/2" (12.7 mm) lg.	Monel		8	
			07932	Screw, H.H.C., 3/8"-16 x 1/2" (12.7 mm) lg.	Stainless Steel UNS-S30400			12
11	--	--	--	Plug, 1/2" NPT	Steel	1	1	1
--Indicates replacement part not available								
Sub-Assembly								
2, 4-8, 10	13397	13399	13482	Clapper Assembly Kit				