



**Wet Pipe Foam/Water Fire Sprinkler System
Supplied by Bladder Tank**

Technical Data Sheet Submittal Package

for the

Viking SFFF USP & ARK Concentrates



TECHNICAL BULLETIN

WET PIPE FOAM/WATER SYSTEM SUPPLIED BY BLADDER TANK

The Viking Corporation, 210 N Industrial Park Drive, Hastings MI 49058

Telephone: 269-945-9501 Technical Services: 877-384-5464 Fax: 269-818-1680 Email: techsvcs@vikingcorp.com

Visit the Viking website for the latest edition of this technical data page www.vikinggroupinc.com

1. DESCRIPTION

A Wet Pipe Foam/Water System Supplied by Bladder Tank is a standard wet pipe automatic sprinkler system capable of discharging a foam/water solution automatically through any sprinklers that operate. This system consists of a standard wet pipe fire sprinkler system with the addition of a Viking Halar coated deluge valve that is used as a concentrate control valve. Additional equipment includes foam concentrate, a bladder tank for storage, and a proportioning device.

2. LISTINGS AND APPROVALS

No formal approval as a Wet Pipe System. Main component and sub-system approvals below:

- Alarm Check Valve and Trim
UL Listed - Guide VPLX
FM Approved - Waterflow Alarm Valves
- Model VNR Wide Range Proportioner
FM Approved - Low Expansion Foam Systems
- Model F2 or J2 Halar® Coated Concentrate Control Valve (CCV)
UL Listed - Guide VLFT
FM Approved - Automatic Water Control Valve as standard deluge valve. No formal approval available for coating.
- Model VFT Viking Bladder Tank - with ASME Section VIII and/or EN13455 Design Code
UL Listed - Guide GHXV
FM Approved - Low Expansion Foam Systems
- Viking ARK (3% AR-SFFF) Fluorine Free Foam Concentrate
FM Approved
- Viking USP (3% SFFF) Fluorine Free Foam Concentrate
UL Listed
FM Approved

3. TECHNICAL DATA

Specifications:

Refer to individual component technical data pages.

Material Standards:

Refer to individual component technical data pages.

Ordering Information:

Please contact your local Viking office or distributor.

4. INSTALLATION

A. Discharge Devices

- Standard Spray Sprinklers (refer to water/foam sprinkler data page)

B. General Instructions and Warnings

1. Refer to specific technical data sheets, FM Global Property Loss Prevention Data Sheet 4-12, acceptable installation standards, codes and Authority Having Jurisdiction for additional installation, operation and maintenance instructions.
2. The alarm check valve (C) must be installed using the variable pressure trim to minimize false operation of the CCV (D).
3. Inspections - It is imperative that the system be inspected and tested on a regular basis. See Section 6 - Inspections, Tests, and Maintenance.
4. The valve, trim, and assembly must be installed in an area not subject to freezing temperatures or physical damage.

WARNING

After the proportioning system is tested or activated, foam concentrate needs to be flushed from the pipe network downstream of the concentrate control valve. Connect a water supply to the commissioning valve on the concentrate line and flush through the test header.



TECHNICAL BULLETIN

WET PIPE FOAM/WATER SYSTEM SUPPLIED BY BLADDER TANK

The Viking Corporation, 210 N Industrial Park Drive, Hastings MI 49058
 Telephone: 269-945-9501 Technical Services: 877-384-5464 Fax: 269-818-1680 Email: techsvcs@vikingcorp.com
 Visit the Viking website for the latest edition of this technical data page www.vikinggroupinc.com

C. Design and Installation

⚠ WARNING

Any system maintenance or testing that involves placing a control valve or detection system out of service may eliminate the fire protection of that system. Prior to proceeding, notify all Authorities Having Jurisdiction. Consideration should be given to employment of a fire patrol in the affected area.

⚠ WARNING

Locate all portions of the foam/water system subject to freezing in a heated area.

The following guidance is given with reference to the general system schematics (Figures) detailed later in this system manual.

1. Install the alarm check valve and trim (C) in accordance with the relevant Viking technical data page.
2. Install the proportioning device (B) in the system riser in accordance with the wide range proportioner technical data page and Special Notes Section of this System Manual.
3. Install foam solution test valve (22) and system isolation valve (24). These valves are used to conduct foam/water solution tests and are required.
4. Install the (CCV) and associated trim as indicated in Figure 1. FM systems require electrical supervision in accordance with FM Global Property Loss Prevention Data Sheet 4-12.
5. Install bladder tank (A) in accordance with the bladder tank operation manual and the following key notes;
 - a) Recommended connections are shown in Figure 1.
 - b) Locate the tank as close as practical to the system riser. (See Special Note B on Page 7).
 - c) Allow enough room around the tank to perform maintenance on the bladder.
 - d) Allow access to the tank for filling from containers of foam concentrate.
 - e) All valves and devices should be located for easy access for operation and maintenance.
 - f) Install the water supply piping (19) from the riser to the bladder tank as shown in Figure 1.
 - g) Install the piping from the tank (A) to the wide range controller (B) as straight as possible to limit pressure loss.
 - h) Fill bladder tank (A) with foam concentrate in accordance with the bladder tank operation manual and leave isolated from the system.

D. Placing System Into Service & Removing System from Service

1. Placing the System into Service:
 - a) Refer to the Special Notes section on page 7.
 - b) Verify the following valves are in the closed position: water supply control valve (10), PORV activation line ball valve (13), bladder tank water supply control valve (19), 1/2" CCV priming line ball valve (18), concentrate control shut-off valve (20), foam solution test valve (22), foam concentrate auxiliary drain valve (12) and alarm test shut-off valve on the alarm check valve (C), vent valves (1, 3, 12, 30, 31, 32, and 33)
 - c) Place the wet alarm check valve in service in accordance with the relevant Viking technical data page.
 - d) When the system piping is pressurized and has stabilized, prime the CCV (D) by opening and securing the 1/2" CCV priming line ball valve (18) in the open position. When the pressure on the priming chamber water pressure gauge (11) equals the supply water pressure, the deluge valve will close. Bleed off any air pressure trapped in the priming line to the CCV (D) by opening the 3-way pressure gauge valve (11). Once air pressure has been relieved, close the 3-way valve and plug outlet. Re-open 3-way valve to maintain pressure on gauge (11). Continue placing the wet valve in service.
 - e) The wet alarm system (C) should now be in service. To place the bladder tank (A) in service refer to the bladder tank operation manual for the complete start-up procedure.
 - f) Verify the CCV (D) is closed.
 - g) Slowly open the shut-off valves (19) and (20).
 - h) **IMPORTANT:** Bleed air from vent valves (31).



TECHNICAL BULLETIN

WET PIPE FOAM/WATER SYSTEM SUPPLIED BY BLADDER TANK

The Viking Corporation, 210 N Industrial Park Drive, Hastings MI 49058
 Telephone: 269-945-9501 Technical Services: 877-384-5464 Fax: 269-818-1680 Email: techsvcs@vikingcorp.com
 Visit the Viking website for the latest edition of this technical data page www.vikinggroupinc.com

NOTICE

In accordance with the bladder tank operation manual, ensure that CCV (D) is closed, shut-off valves (19) and (20) are opened slowly, and the bladder tank is vented of air.

- i) Open Alarm Shut-Off Valve on Alarm Check Valve (C) Trim.
 - j) When system pressure has stabilized, open PORV actuation ball valve (13).
 - k) Verify normal valve positions and secure in correct position (as detailed in Figure 1).
 - l) Check for and repair any leaks in the foam/water system pipe network.
2. For System and Riser Piping Service and Maintenance:
- a) Refer to the Special Notes section on page 7.
 - b) Close the water supply control valve (10).
 - c) Close the bladder tank water supply control valve (19), concentrate control shut-off valve (20) and PORV activation line ball valve (13).
 - d) Leave the system isolation valve (24) open.
 - e) Refer to instructions for removing the alarm check valve (C) from service in the relevant Viking technical data page.
 - f) Open the main drain on alarm check valve (C) and sprinkler system auxiliary drain valves and remote inspector's test valve to vent system as required.
 - g) Perform required service and maintenance on system devices or piping network.
 - h) Refer to instructions for returning the alarm check valve (C) to service in the relevant Viking technical data page.
 - i) Verify that the CCV (D) is closed by checking water pressure gauge (11) to ensure that it is the same as or higher than the system pressure.
 - j) **IMPORTANT:** Bleed air from vent valves (31).

NOTICE

In accordance with the bladder tank operation manual, ensure that CCV (D) is closed, shut-off valves (19) and (20) are opened slowly, and the bladder tank is vented of air.

- k) Open tank water supply valve (19) and concentrate control shut-off valve (20).
 - l) Open shut-off valve on alarm check valve (C) trim.
 - m) When system pressure has stabilized, open PORV actuation ball valve (13).
 - n) Verify normal valve positions and secure in correct position (as detailed in Figure 1).
3. For Total System Service and Maintenance:
- a) Refer to the Special Notes section on page 7.
 - b) Close the water supply control valve (10).
 - c) Close the bladder tank water supply control valve (19), concentrate control shut-off valve (20) PORV actuation line ball valve (13) and 1/2" CCV priming line ball valve (18).
 - d) Leave the system isolation valve (24) open.
 - e) Refer to instructions for removing the alarm check valve (C) from service in the relevant Viking technical data page.
 - f) Open the main drain on alarm check valve (C) and sprinkler system auxiliary drain valves and remote inspector's test valve to vent system as required.
 - g) Relieve pressure on CCV priming line through the 3-way gauge valve (11).
 - h) Perform required service and maintenance on system devices or piping network.
 - i) Refer to instructions for removing the bladder tank (A) from service in the bladder tank operation manual.
 - j) Perform required service and maintenance on bladder tank (A) in accordance with the bladder tank operation manual.
 - k) To return the system into service, follow steps 1a through 1i in Section D above.
4. For Bladder Tank Service and Maintenance - While Leaving Wet System in Service:
- a) Refer to the Special Notes section on page 7.
 - b) Close the bladder tank water supply control valve (19), concentrate control shut-off valve (20) and PORV actuation line ball valve (13).
 - c) Refer to instructions for removing the bladder tank (A) from service in the bladder tank operation manual.



TECHNICAL BULLETIN

WET PIPE FOAM/WATER SYSTEM SUPPLIED BY BLADDER TANK

The Viking Corporation, 210 N Industrial Park Drive, Hastings MI 49058

Telephone: 269-945-9501 Technical Services: 877-384-5464 Fax: 269-818-1680 Email: techsvcs@vikingcorp.com

Visit the Viking website for the latest edition of this technical data page www.vikinggroupinc.com

- d) Perform required service and maintenance on bladder tank (A) in accordance with the bladder tank operation manual.
- e) To place the bladder tank (A) in service refer to the bladder tank operation manual for the complete start-up procedure.
- f) **IMPORTANT:** Bleed air from vent valves (31).

NOTICE

In accordance with the bladder tank operation manual, ensure that CCV (D) is closed, shut-off valves (19) and (20) are opened slowly, and the bladder tank is vented of air.

- g) Open alarm shut-off valve on alarm check valve (C) trim.
 - h) When system pressure has stabilized, open PORV actuation ball valve (13).
 - i) Verify normal valve positions and secure in correct position (as detailed in Figure 1).
5. For Riser Only Service and Maintenance:
- a) Refer to the Special Notes section on page 7.
 - b) Close the water supply control valve (10).
 - c) Close the bladder tank water supply control valve (19), concentrate control shut-off valve (20) and PORV activation line ball valve (13).
 - d) Close the system isolation valve (24).
 - e) Refer to instructions for removing the alarm check valve (C) from service in the relevant Viking technical data page.
 - f) Open the main drain check valve (C).
 - g) Perform required service and maintenance on the check valve.
 - h) Refer to instructions for returning the alarm check valve (C) to service in the relevant Viking technical data page.
 - i) **IMPORTANT:** Bleed air from vent valves (31).

NOTICE

In accordance with the bladder tank operation manual, ensure that CCV (D) is closed, shut-off valves (19) and (20) are opened slowly, and the bladder tank is vented of air.

- j) Open the system isolation valve (24).
 - k) Open tank water supply valve (19) and concentrate control shut-off valve (20).
 - l) Open alarm shut-off valve on alarm check valve (C) trim.
 - m) When system pressure has stabilized, open PORV actuation ball valve (13).
 - n) Verify normal valve positions and secure in correct position (as detailed in Figure 1).
6. Testing the foam concentrate swing check valve:
- After a flow test or proportioning test has been conducted, the foam concentrate swing check valve (21) should be checked to ensure that it maintains a positive seal between the CCV (D) and the riser by following the procedure outlined below.
- a) Bleed off any pressure which may have been trapped between the outlet of the chamber of the CCV (D) and the swing check valve (21) by placing a container under the foam concentrate auxiliary drain valve (12) and opening the valve slowly.
 - b) Drain excess foam concentrate into container. Should the leakage continue, check the priming pressure gauge (11) on the CCV (D) to ensure that the valve is primed and closed.
 - c) If the foam concentrate auxiliary drain valve (12) continues to leak foam concentrate, then the CCV (D) must be checked for proper operation and repaired if necessary. Follow the procedure in section 4 D.5 and refer to component data page for repair instructions.
 - d) Should water continue to leak from the foam concentrate auxiliary drain valve (12), the foam concentrate swing check valve (21) clapper rubber and seat should be repaired. Follow the procedure in section D.5 and refer to component data page for repair instructions.

E. Troubleshooting

1. For operating and maintenance instructions pertaining to Viking manufactured equipment, refer to the appropriate section of the Viking Website.



TECHNICAL BULLETIN

WET PIPE FOAM/WATER SYSTEM SUPPLIED BY BLADDER TANK

The Viking Corporation, 210 N Industrial Park Drive, Hastings MI 49058

Telephone: 269-945-9501 Technical Services: 877-384-5464 Fax: 269-818-1680 Email: techsvcs@vikingcorp.com

Visit the Viking website for the latest edition of this technical data page www.vikinggroupinc.com

2. For operating and maintenance instructions pertaining to foam equipment manufactured for Viking, refer to the Foam section on the Viking Website.
3. For operation and maintenance instructions for all other equipment, refer to appropriate equipment data.

F. Emergency Instructions

1. During and after a fire:
 - a) Make sure the fire is OUT! Make a complete inspection of all areas covered by this system including areas not involved in the fire. Place a fire watch in the entire area until the system is back in service. NOTE: If the fire is not out, DO NOT turn the alarm off by placing the alarm shut-off valve in the closed position.
 - b) Close the system water supply control valve (10) and the tank water supply valve (19). Post a person at the valve ready to turn them back on, should the fire rekindle.
 - c) Replace all operated and damaged sprinklers with the same type and temperature rating as were removed. Open main drain if necessary.
 - d) Check the level of foam concentrate and refill the foam concentrate bladder tank (A) in accordance with the bladder tank operation manual. Always replace the foam concentrate with the same brand and type as that being used currently.

NOTE: *Never intermix different types or brands of foam concentrate, as this could cause them to gel or solidify, and render the concentrate useless.*
 - e) Return the complete system to service by following the procedure listed in Section 4.D.1, Steps a through i.
 - f) Perform quarterly test. See Special Note E on Page 7 for special instructions.
 - g) Fire can damage piping and supports, so call your Viking representative for additional replacement sprinklers. For additional details, see technical data sheets for specific device.

NOTE: *If replacement foam concentrate is not immediately available, activate the wet pipe portion of the foam/water system until the replacement foam concentrate arrives.*
2. If the discharge system is damaged and the system is flowing water:
 - a) Close the water supply control valve (10) to shut off the water supply
 - b) Close the concentrate control shut-off valve (20) to eliminate the flowing of the foam concentrate to the CCV (D) and the wide range proportioner (B).
 - c) Close the tank water supply control valve (19) to reduce the pressure on the bladder tank (A).
 - d) Close the system isolation valve (24), to stop the flow of water/foam solution into the discharge system.
 - e) Place the alarm shut-off valve on the alarm valve (C) trim in the closed position to reestablish the prime pressure on the CCV (D).
 - f) Repair the damaged portion of the discharge system.
 - g) Return the riser and the foam system to service, following the procedure listed above in section 4.D.4, steps A through F.
3. If the foam concentrate pipe system is damaged:
 - a) Close the concentrate control shut-off valve (20) to eliminate the flowing of the foam concentrate to the CCV (D) and the ratio controller (B).
 - b) Close the tank water supply control valve (19) to reduce the pressure on the bladder tank (A).
 - c) Repair the damaged portion of the foam concentrate pipe system.
 - d) Return the foam concentrate system to service. Follow the procedure listed above in section 4.D.4 steps A through F.

NOTE: *If there are no damaged sections of the distribution system, the wet pipe portion of the sprinkler system may be kept in service for protection while repairs to the foam concentrate system are performed.*

5. OPERATION

Actuation of a sprinkler allows system water to flow causing the alarm check valve (C) clapper to open. The retard chamber and alarm line are filled, pressurizing the PORV (14) and connected alarm devices. Operation of the PORV (14) relieves pressure from the priming chamber of the CCV (D) allowing the valve to open. If fitted, the priming line pressure switch (29) will signal the CCV's activation. The bladder tank (A) is already pressurized by the water supply piping. System water pressure in the space between the flexible bladder and the inside surface of the steel tank causes the bladder to collapse, forcing the foam concentrate out through the foam concentrate discharge piping, CCV (D), and wide range proportioner (B). The foam concentrate is proportioned with the main water supply, sending foam solution to the sprinklers or other foam/water discharge devices downstream



TECHNICAL BULLETIN

WET PIPE FOAM/WATER SYSTEM SUPPLIED BY BLADDER TANK

The Viking Corporation, 210 N Industrial Park Drive, Hastings MI 49058

Telephone: 269-945-9501 Technical Services: 877-384-5464 Fax: 269-818-1680 Email: techsvcs@vikingcorp.com

Visit the Viking website for the latest edition of this technical data page www.vikinggroupinc.com

6. INSPECTIONS, TESTS AND MAINTENANCE

⚠ WARNING

Any system maintenance or testing that involves placing a control valve or detection system out of service may eliminate the fire protection of that system. Prior to proceeding, notify all Authorities Having Jurisdiction. Consideration should be given to employment of a fire patrol in the affected area.

NOTICE

The owner is responsible for maintaining the fire protection system and devices in proper operating condition. For minimum maintenance and inspection requirements, refer to recognized standards such as those produced by NFPA, FM Global Property Loss Prevention Data Sheet 4-12, LPC and VdS, which describe care and maintenance of sprinkler systems. In addition, the Authority Having Jurisdiction may have additional maintenance, testing, and inspection requirements that must be followed.

It is imperative that the system be inspected and tested on a regular basis. The following recommendations are minimum requirements. The frequency of the inspections may vary due to contaminated or corrosive water supplies and corrosive atmospheres. In addition, the alarm devices or other connected equipment may require more frequent inspections. Refer to the technical data, system description, applicable codes and Authority Having Jurisdiction for minimum requirements. Prior to testing the equipment, notify appropriate personnel.

- A. Alarm Test - Please refer to Special Note E before performing an alarm test, otherwise, an unwanted release of foam concentrate will occur. At least quarterly, test all connected alarm devices by opening the remote inspector's test valve.
- B. Riser Flow Test - Please refer to Special Note E and Section 4-D, before performing the riser flow test, otherwise, an unwanted release of foam concentrate will occur. At least quarterly, perform a riser flow test. Observe and record the supply pressure gauge reading. Open the main drain valve fully. Again, observe and record the supply pressure gauge reading. Close the main drain valve. If the readings vary significantly from those previously established or from normal, check the main supply line for obstructions or closed valves and correct any problems found.
- C. General - Visually inspect the valve, trim, piping, alarm devices, and connected equipment for physical damage, freezing, corrosion, or other conditions that may inhibit the proper operation of the system.

7. AVAILABILITY

The Wet Pipe Foam/Water System Supplied by Bladder Tank is available through a network of domestic and international distributors. See the Viking web site for closest distributor or contact Viking.

8. GUARANTEE

For details of warranty, refer to Viking's current list price schedule or contact Viking directly.



TECHNICAL BULLETIN

WET PIPE FOAM/WATER SYSTEM SUPPLIED BY BLADDER TANK

The Viking Corporation, 210 N Industrial Park Drive, Hastings MI 49058
 Telephone: 269-945-9501 Technical Services: 877-384-5464 Fax: 269-818-1680 Email: techsvcs@vikingcorp.com
 Visit the Viking website for the latest edition of this technical data page www.vikinggroupinc.com

SPECIAL NOTES

⚠ WARNING

Turning off the alarm test shut-off valve during a fire may cause the concentrate control valve to close, stopping the flow of foam concentrate. The installing contractor should post a sign stating the same at alarm shut-off valve and/or install a monitor switch on the alarm shut-off valve.

- A. Provide a minimum of 5 pipe diameters of straight pipe on the inlet and outlet of the wide range proportioner (B) to minimize turbulence inside the proportioner. Exception: The outlet for the tank water supply control valve may be connected nearer to the inlet of the proportioner and should not cause excessive turbulence. However, if the outlet to the foam solution test valve (22) is located closer than 5 pipe diameters, there may be turbulence at high flow rates.
- B. The combined total equivalent length of pipe (pipe length, plus equivalent lengths for fittings and valves) on the water supply inlet piping (19) shall be less than 100' (30.5 m) and the foam concentrate discharge piping (20), should be less than 65 equivalent feet (50.3 meters).
- C. The CCV (D) and swing check valve (21) must be connected adjacent to the wide range proportioner using the shortest pipe nipples as possible.
- D. The alarm check valve must be installed using the variable pressure trim and retard chamber to minimize false operation of the CCV (D). The releasing PORV (14) for the CCV (D) is activated by the operation of the alarm valve.
- E. Ball Valve (13) must be left in the open position, except when conducting alarm or flow test. Failure to close this valve before running an alarm or flow test will result in the unwanted discharge of foam concentrate. Once the test is completed, the valve must be returned to the open position, or the foam CCV (D) will not operate, and the foam concentrate will not flow to the wide range proportioner.
- F. The suggested location for a water flow switch, should one be required, is between the outlet of the alarm check valve (C) and the inlet to the ratio controller.
- G. Figure 1 is a general schematic of the required piping arrangement. Refer to the appropriate technical data page for specific information regarding the valve, tank, and related trim and devices.
- H. The technical information, statements, and recommendations contained in this manual are based on information and tests which, to the best of our knowledge, we believe to be dependable. It represents general guidelines only, and the accuracy or completeness thereof, are not guaranteed since conditions of handling and usage are outside our control. The purchaser should determine the suitability of the product for its intended use and assumes all risks and liability whatsoever in connection therewith.
- I. A strainer is not required in the foam concentrate discharge piping of bladder tank systems per NFPA Standards.
- J. The CCV (D) requires a 1/2" priming line with CCV priming connection package. This package includes PORV (14), restricted orifice (16), check valve (15), strainer (17) and ball valve (18). Auxiliary drain valve and gauge with 3-way valve are included in the CCV Trim kit along with the plugs required for all other unused connections. Refer to the Viking website to find the correct trim kit part number for the corresponding size of CCV (D).
- K. FM Global Property Loss Prevention Data Sheet 4-12 requires that the activation of the CCV must be supervised.



TECHNICAL BULLETIN

WET PIPE FOAM/WATER SYSTEM SUPPLIED BY BLADDER TANK

The Viking Corporation, 210 N Industrial Park Drive, Hastings MI 49058

Telephone: 269-945-9501 Technical Services: 877-384-5464 Fax: 269-818-1680 Email: techsvcs@vikingcorp.com

Visit the Viking website for the latest edition of this technical data page www.vikinggroupinc.com

- A. Foam Concentrate Bladder Tank**
 1. Water Vent Valve – NORMALLY CLOSED
 2. Safety Thermal Relief Valve
 3. Foam Concentrate Vent Valve – NORMALLY CLOSED
 4. Filling Vent Valve (Optional)
 5. Filling Pressure Gauge (Optional)
 6. Water filling/drain valve –NORMALLY CLOSED
 7. Foam concentrate filling/drain valve – NORMALLY CLOSED
 8. Concentrate level sight tube drain valve – NORMALLY CLOSED
 9. Concentrate level sight tube
- B. Proportioning Device – Wide Range Proportioner ****
- C. Type of System – Alarm check valve with trim & retard chamber (Each item below sold separately)**
 10. Water Supply Control Valve – NORMALLY OPEN
- D. Concentrate Control Valve (CCV) (Hydraulically activated Halon® coated straight through deluge valve)**
 11. CCV Priming pressure gauge
 12. 1/2" Foam concentrate auxiliary drain valve
 13. 1/2" PORV Water supply ball valve – NORMALLY OPEN
- Prime Line Connection Package**
 14. Pressure Operated Relief Valve (PORV)
 15. 1/2" Soft seat check valve
 16. Restricted orifice 0.125"
 17. 1/2" Strainer
 18. 1/2" Ball valve – NORMALLY OPEN
- Accessory Trim – (Each item below sold separately)**
 19. Bladder tank water supply control valve – NORMALLY OPEN
 20. Foam concentrate shut-off valve – NORMALLY OPEN* (INSTALLED HORIZONTALLY AS SHOWN)
 21. Foam concentrate swing check valve
 22. Foam solution test valve – NORMALLY CLOSED
 23. Foam solution test header
 24. Foam system isolation valve – NORMALLY OPEN
 25. Mechanical alarm and/or alarm pressure switch
 26. 1/2" Automatic ball drip valve
 27. Fire Department Connection (FDC) Check valve
 28. FDC
 29. Prime line supervision switch
- Commissioning and Flushing Valves**
 30. 2 1/2" Ball Valves (2) - NORMALLY CLOSED (Installed on customer-supplied outlet)
- Air Vent and Drain Valves**
 31. 1/2" Air vent valves (2) - NORMALLY CLOSED (Installed on customer-supplied outlet)
 32. 1/2" Drain valve (1) - NORMALLY CLOSED (Installed on customer-supplied outlet)
- Bladder Tank Dip Valve**
 33. 1" Dip valve - NORMALLY CLOSED (Installed on customer-supplied outlet)

*Full port bronze body with 316 stainless steel trim and ball valve
 **Five pipe diameters required before and after the proportioner.

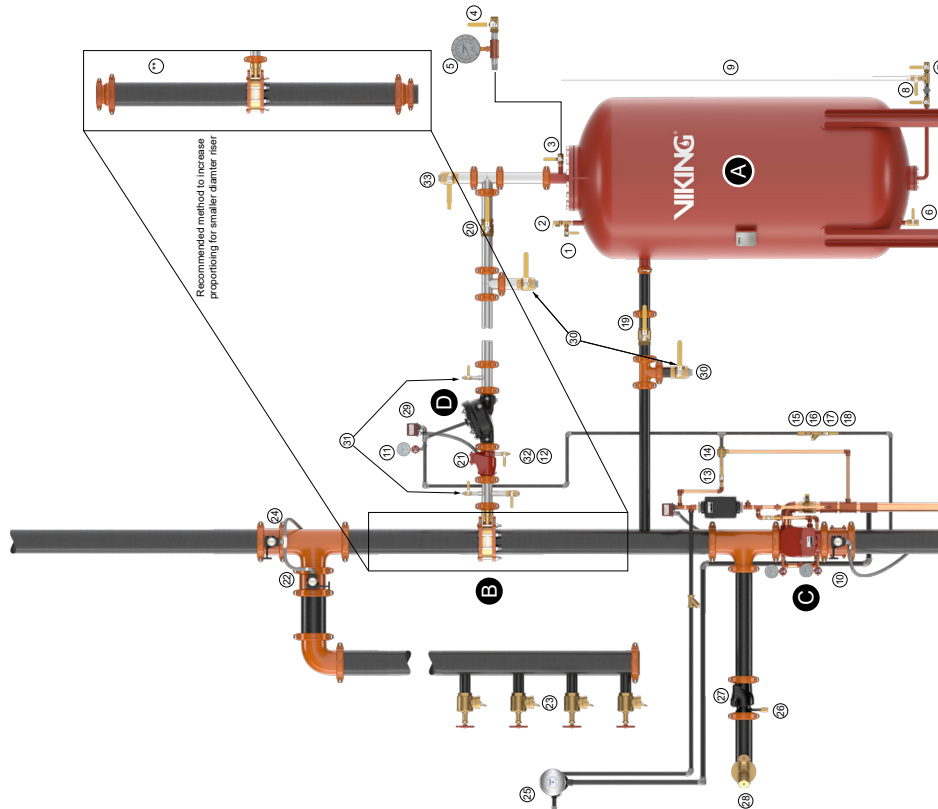

Figure 1

	<h1 style="margin: 0;">TECHNICAL BULLETIN</h1>	<h2 style="margin: 0;">WET PIPE FOAM/WATER SYSTEM SUPPLIED BY BLADDER TANK</h2>
---	--	---

The Viking Corporation, 210 N Industrial Park Drive, Hastings MI 49058
 Telephone: 269-945-9501 Technical Services: 877-384-5464 Fax: 269-818-1680 Email: techsvcs@vikingcorp.com
 Visit the Viking website for the latest edition of this technical data page www.vikinggroupinc.com

ORDERING INSTRUCTIONS:

For complete Wet Pipe Foam/Water System Supplied by a Bladder Tank, select 1 each of the following as well as all desired Accessories from the tables below:

- Alarm Check Valve and Trim
- Retard Chamber and Circuit Closer Vent Trim
- Pilot Operated Pressure Control Valve
- Foam Concentrate Control Valve and Trim,
- Foam Concentrate
- Wide Range Proportioner
- Bladder Tank

Scan or click to visit Viking's digital system estimators.



<https://digital.vikingcorp.com>

DESCRIPTION	NOMINAL SIZE	PART NUMBER	
Alarm Check Valves			
Flange/ Flange	Flange Drilling	Model J-1	
	ANSI	3"	08235
	ANSI	4"	08238
	ANSI	6"	08241
	ANSI	8"	08244
	PN10/16	DN80	09108
	PN10/16	DN100	09109
	PN10/16	DN150	09110
	PN10	DN200	09111
PN16	DN200	12388	
Flange/ Groove	Flange Drilling / Pipe O.D.	Model J-1	
	ANSI / 89 mm	3"	08236
	ANSI / 114 mm	4"	08239
	ANSI / 168 mm	6"	08242
	ANSI / 219 mm	8"	08245
	PN10/16 / 89 mm	DN80	09535
	PN10/16 / 114 mm	DN100	09536
	PN10/16 / 168 mm	DN150	09874
	PN10 / 219 mm	DN200	09877
PN16 / 219 mm	DN200	12389	
Groove/ Groove	Pipe O.D.	Model J-1	
	89 mm	3" / DN80	08237
	114 mm	4" / DN100	08240
	165 mm	DN150	09405
	168 mm	6" / DN150	08243
219 mm	8" / DN200	08246	
Alarm Check Valve Trim			
Vertical	3" / DN80	11428	
	4" / DN100	11429	
	6" / DN150	11430	
	8" / DN200	11431	
Horizontal	3" / DN80	11432	
	4" / DN100	11433	
	6" / DN150	11434	
	8" / DN200	11435	

DESCRIPTION	NOMINAL SIZE	PART NUMBER
Miscellaneous		
CIRCUIT CLOSER VENT BRASS TRIM		08220
MODEL C-1 RETARDING CHAMBER (not included in the trim)		05904B

DESCRIPTION	NOMINAL SIZE	PART NUMBER
Foam Concentrate Control Valves (Halar® Coated)		
Straight Through		
Groove/ Groove	Pipe O.D.	Model F-2
	73 mm	2½" / DN65
		12404Q/B

DESCRIPTION	NOMINAL SIZE	PART NUMBER
CCV Trims		
Use with Straight Through Valves	Brass	
	2½" / DN65	12929-2

DESCRIPTION	PRESSURE RATING	TANK SIZE	DESIGN CODE	PART NUMBER
Vertical Bladder Tank	175psi (12bar)	25 to 4000 US Gallon	EN13445	VFTV****GF
Horizontal Bladder Tank	175psi (12bar)	50 to 5250 US Gallon	EN13445	VFTH****GF
Vertical Bladder Tank	232psi (16bar)	25 to 4000 US Gallon	EN13445	VFTV****GF-16
Horizontal Bladder Tank	232psi (16bar)	50 to 5250 US Gallon	EN13445	VFTH****GF-16
Vertical Bladder Tank	175psi (12bar)	25 to 4000 US Gallon	ASME Sec.VIII Div.1	VFTV****GAF
Horizontal Bladder Tank	175psi (12bar)	50 to 5250 US Gallon	ASME Sec.VIII Div.1	VFTH****GAF
Vertical Bladder Tank	232psi (16bar)	25 to 4000 US Gallon	ASME Sec.VIII Div.1	VFTV****GAF-16
Horizontal Bladder Tank	232psi (16bar)	50 to 5250 US Gallon	ASME Sec.VIII Div.1	VFTH****GAF-16

Where **** is the tank size in US Gallon



TECHNICAL BULLETIN

**WET PIPE
FOAM/WATER SYSTEM
SUPPLIED BY BLADDER
TANK**

The Viking Corporation, 210 N Industrial Park Drive, Hastings MI 49058
Telephone: 269-945-9501 Technical Services: 877-384-5464 Fax: 269-818-1680 Email: techsvcs@vikingcorp.com
Visit the Viking website for the latest edition of this technical data page www.vikinggroupinc.com

Accessories		
DESCRIPTION	NOMINAL SIZE	PART NUMBER
Foam Concentrate Swing Check Valve		
	2½" / DN65	05497C
Foam Solution Test Valve		
Grooved Butterfly Valve	2½" / DN65	01G-0250
	3" / DN80	01G-0300
	4" / DN100	01G-0400
	6" / DN150	01G-0600
	8" / DN200	01G-0800
System Isolation Valve		
Grooved Butterfly Valve	2½" / DN65	01G-0250
	3" / DN80	01G-0300
	4" / DN100	01G-0400
	6" / DN150	01G-0600
	8" / DN200	01G-0800
Water Supply Control Valve		
Grooved Butterfly Valve	2½" / DN65	01G-0250
	3" / DN80	01G-0300
	4" / DN100	01G-0400
	6" / DN150	01G-0600
	8" / DN200	01G-0800
Foam Concentrate Shut-Off Valve		
Ball Valve	2½" / DN65	23247
ACCESSORIES FOR FOAM/WATER SPRINKLER SYSTEMS		
Model D-3 PORV	½" / DN15	16970
1/8" / 3 mm Restricted Orifice	½" / DN15	06555A
Soft Seat Check Valve	½" / DN15	03945A
Y Strainer	½" / DN15	01054A
Ball Valve	½" / DN15	10355
Pressure switch	½" NPT	PS10
Concentrate Control Valve Priming Connection Pkg.		
Required to connect priming chamber		10985
Bladder Tank Water Supply Control Valve		
Ball Valve	2½" / DN65	23247
Vent Valves		
Ball Valve	½" / DN15	10355
Ball Valve	1" / DN25	10356

Wide Range Proportioner			
Connection		Foam Type	Part Number
"Body Grooved"	"Foam Inlet Grooved"		
6" (150mm)	2.5" (73.0mm)	ARK (3% SFFF)	VNR063P
8" (200mm)	2.5" (73.0mm)		VNR083P
6" (150mm)	2.5" (73.0mm)	USP (3% SFFF)	VNR063L
8" (200mm)	2.5" (73.0mm)		VNR083L

Foam Concentrate			
Foam Type	Part Number		
	US Gallon		
	6.5	55	265
ARK (3% AR-SFFF)	F24175-6.5	F24175-55	F24175-265
USP (3% SFFF)	F21720-6.5	F21720-55	F21720-265



TECHNICAL DATA

MODEL VNR WIDE RANGE PROPORTIONER

The Viking Corporation, 5150 Beltway Dr. SE, Caledonia MI, 49316

Telephone: 269-945-9501 Technical Services: 877-384-5464 Fax: 269-818-1680 Email: techsvcs@vikingcorp.com

Visit the Viking website for the latest edition of this technical data page www.vikinggroupinc.com

1. DESCRIPTION

The wide range proportioner accurately proportions foam concentrate into a water stream over a wide range of system flow rates. The device is configured to proportion foam concentrate at a 3% ratio. Wide range proportioners are an integral part of an approved foam system. In addition to the wide range proportioner, the main components of the approved foam system are: foam concentrate, a foam storage tank, a concentrate control valve, and foam discharge devices.

The system must be designed so that the wide range proportioner can accurately proportion foam over the range of flow rates expected during the system operation.

The wide range proportioner has the capability to accurately proportion foam concentrate into the water supply at low flow rates as required when only a small quantity of sprinklers have activated.

Please refer to specific system manual(s) for further information.

For further information, please contact the appropriate sales office in **Section 5**, or refer to the technical documentation.

The contents of this publication are subject to modifications without notice.

2. LISTINGS AND APPROVALS

FM Approved – Low Expansion Foam Systems (FM5130)



The wide range proportioner is FM Approved as part of a fire extinguishing system combining designated foam concentrates, bladder tanks and discharge devices. Approved system components can be found at www.approvalguide.com

Other International approval certificates may be available upon request.

"SFFF compatible" refers to this product as being part of a SFFF Foam system that has been tested to recognized standards. Not all configurations are available. Please consult technical data and/or the Approval/Listing for usage requirements.

3. TECHNICAL DATA

3.1 Construction features

- Available in 6" (DN150) and 8" (DN200) sizes
- Wafer connection for installation between ANSI and PN16 flanges
- Brass construction
- Horizontal or vertical installation
- Direction of flow indicator on body
- For use with fresh or salt water
- Identification tag plate

3.2 Standard Design Specifications

Table 3.2.1 - Standard design specifications

Table 3.2.1 - Standard design specifications	
Design pressure	250 psi / 17.2 bar (1.7 MPa)
Test pressure	500 psi / 34.4 bar (3.4 Mpa)
Design temperature range	14 °F to 120 °F (-10 °C to 49 °C)
Operating temperature range	35 °F to 120 °F (1.7 °C to 49 °C) (as per FM 5130)
Minimum operating inlet pressure	30 psi / 2.1 bar (0.2 MPa)
Maximum operating inlet pressure	175 psi / 12.1 bar (1.2 MPa)
Proportioning range	See Table 3.5.1



WARNING: Cancer and Reproductive Harm-
www.P65Warnings.ca.gov





TECHNICAL DATA

MODEL VNR WIDE RANGE PROPORTIONER

The Viking Corporation, 5150 Beltway Dr. SE, Caledonia MI, 49316
 Telephone: 269-945-9501 Technical Services: 877-384-5464 Fax: 269-818-1680 Email: techsvcs@vikingcorp.com
 Visit the Viking website for the latest edition of this technical data page www.vikinggroupinc.com

3.3 Components and Dimensions

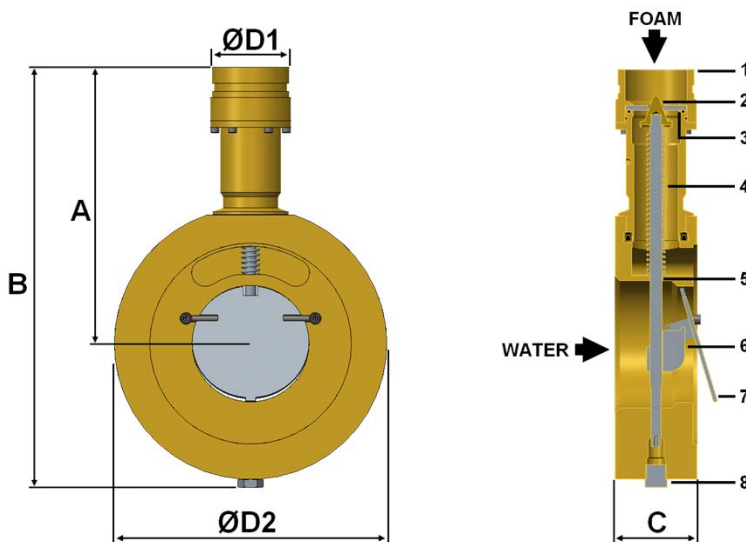

Figure 3.2.1: Components and Dimensions

Table 3.3.1 - Components					
Item	Description	Item	Description	Item	Description
1	Grooved foam inlet	4	Spring	7	Clapper
2	Orifice restrictor	5	Rod	8	Plug
3	Orifice plate	6	Threaded collar	-	-

Table 3.3.2 – Weights and Dimensions										
Nominal size (D2)	Approximate weight		Approximate dimensions							
			A		B		C		Foam inlet (D1)	
	lbs	kg	Inch	mm	Inch	mm	Inch	mm	Inch	mm
6" (150 mm) Wafer	47	21	9-1/4	236	13	353	2-3/4	70	2.5	76.1
6" (150 mm) Wafer	47	21	9-1/4	236	13	353	2-3/4	70	2.5	73.0
8" (200 mm) Wafer	71	32	10-7/8	277	16-1/2	419	3-1/4	82	2.5	76.1
8" (200 mm) Wafer	71	32	10-7/8	277	16-1/2	419	3-1/4	82	2.5	73.0

3.4 Standard Materials

Table 3.4.1 - Standard materials	
Body, neck, grooved inlet	Brass EN CB491K
Rod, clapper, threaded collar	Stainless steel
Orifice plate	UNS C95800
Spring	Stainless steel AISI-302 (DIN 17224)



TECHNICAL DATA

MODEL VNR WIDE RANGE PROPORTIONER

The Viking Corporation, 5150 Beltway Dr. SE, Caledonia MI, 49316

Telephone: 269-945-9501 Technical Services: 877-384-5464 Fax: 269-818-1680 Email: techsvcs@vikingcorp.com

Visit the Viking website for the latest edition of this technical data page www.vikinggroupinc.com

3.5 Ordering information

1. This wide range proportioner is for use with listed and approved foam concentrates at 3% proportioning rates.
2. The minimum and maximum flow demand of the fire protection system must be known to ensure correct selection of the wide range proportioner. The required minimum flow rate should be higher than the minimum flow rate shown in **Table 3.5.1**. The required higher flow rate should be lower than the maximum flow rate shown in **Table 3.5.1**. If more than one size is suitable, size selection can then be based on the size of the riser or supply pipework into which the wide range proportioner will be installed.
3. After selecting the size, check the appropriate graph in **Section 6.2** to ensure the required flows are possible at the available system pressure. If not, it may be necessary to increase to the next pipe size.

Table 3.5.1 - Ordering information

Connection		Foam type	Part number	Foam inlet orifice size ³		FM approved			
Body wafer ²	Foam inlet grooved			Minimum flow rate ¹		Maximum flow rate ¹			
				Inch	mm	GPM	l/min	GPM	l/min
6" (150mm)	2.5" (76.1mm)	Viking ARK, 3%	VNR066P	0.717	18.2	50	189	1895	7,173
		Viking USP, 3%	VNR066L	0.709	18.0	50	189	1420	5375
6" (150mm)	2.5" (73.0mm)	Viking ARK, 3%	VNR063P	0.717	18.2	50	189	1895	7,173
		Viking USP, 3%	VNR063L	0.709	18.0	50	189	1420	5375
8" (200mm)	2.5" (76.1mm)	Viking ARK, 3%	VNR086P	0.945	24.0	50	189	3003	11,368
		Viking USP, 3%	VNR086L	0.929	23.6	50	189	3010	11,394
8" (200mm)	2.5" (73.0mm)	Viking ARK, 3%	VNR083P	0.945	24.0	50	189	3003	11,368
		Viking USP, 3%	VNR083L	0.929	23.6	50	189	3010	11,394

NOTES:
¹ Please refer to graphs in **Section 6.2** for specific flow rate parameters.
² Can be installed between ANSI or PN16 flanges
³ Foam inlet orifice is variable up to the point when the hinged clapper is fully open

4. SCOPE OF DELIVERY

- a) Ensure that all components are complete and in good condition.
- b) Check that the tamper proof seal on bottom plug is not damaged or removed. In case of either scenario, report immediately to supplier.
- c) The wide range proportioner is supplied boxed, with a fixed data plate and an integral sized orifice disc specific to its approved/ listed foam concentrate.
- d) Grooved couplings and flange kits are not included.

5. AVAILABILITY

Please contact your local Viking sales office for further information. The product is available directly from Viking and official distributors only.

Americas:

The Viking Corporation

5150 Beltway SE

Caledonia, MI 49316

Tel.: (800) 968-9501

Fax: 269-818-1680

Technical Services: 1-877-384-5464

techsvcs@vikingcorp.com



TECHNICAL DATA

MODEL VNR WIDE RANGE PROPORTIONER

The Viking Corporation, 5150 Beltway Dr. SE, Caledonia MI, 49316
 Telephone: 269-945-9501 Technical Services: 877-384-5464 Fax: 269-818-1680 Email: techsvcs@vikingcorp.com
 Visit the Viking website for the latest edition of this technical data page www.vikinggroupinc.com

6. PERFORMANCE DATA

6.1 Friction loss vs foam solution flow

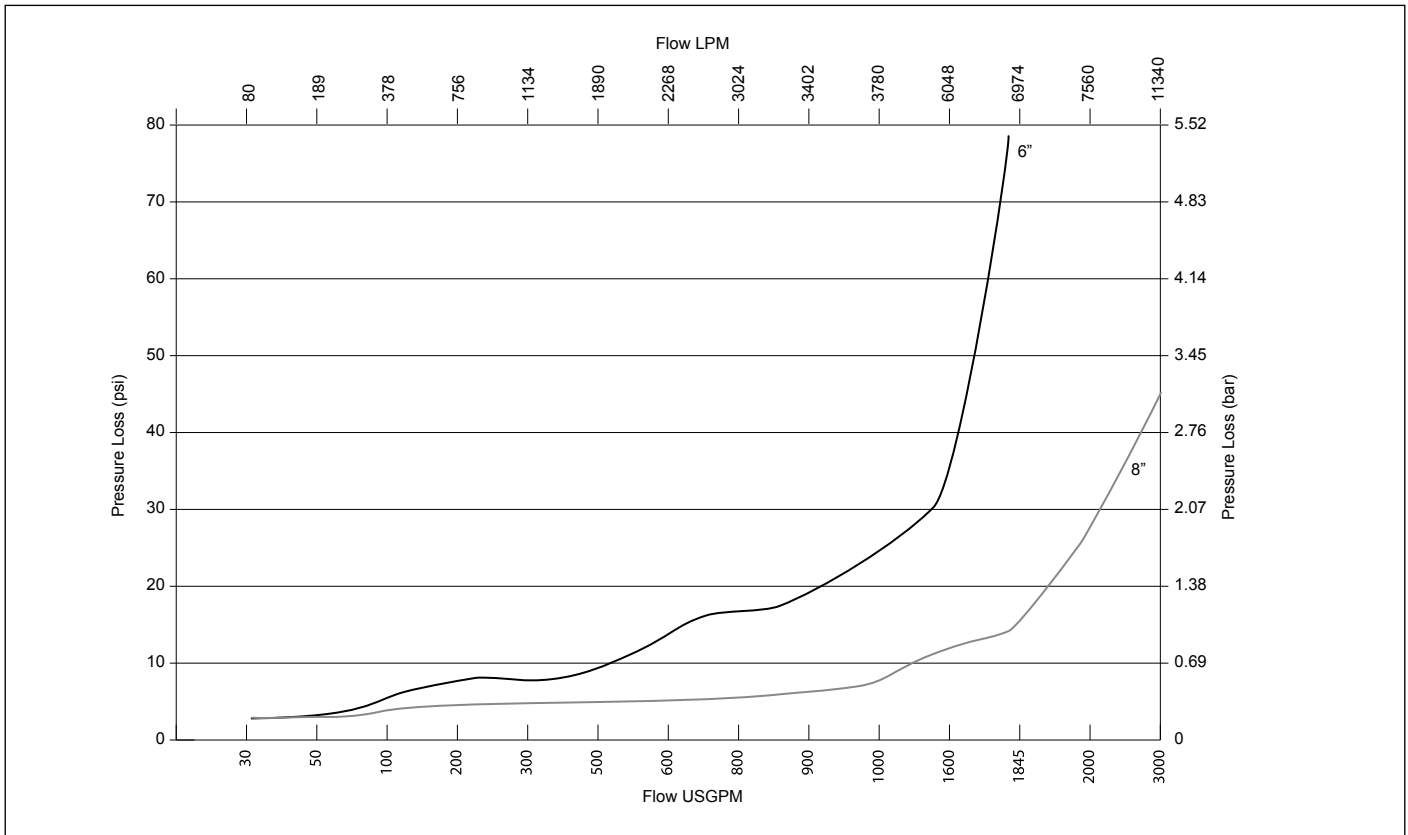

6.2 Inlet pressure vs foam solution flow

Wide range proportioner must be used within the shaded flow and pressure conditions.

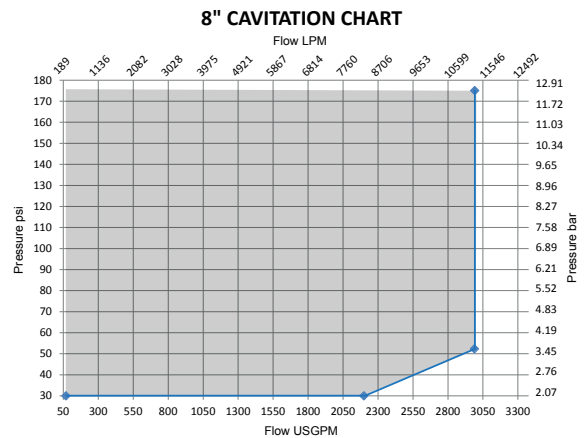
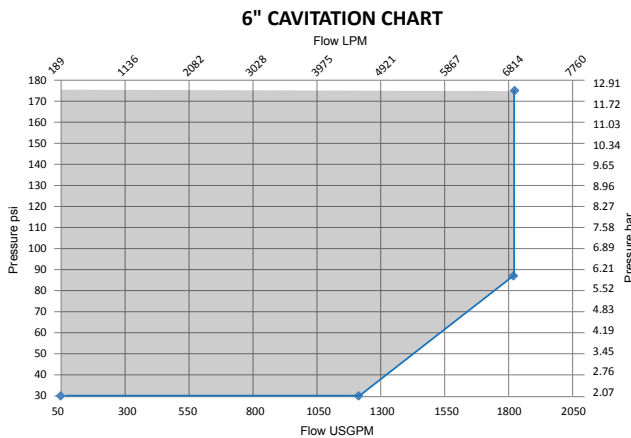



TECHNICAL DATA

MODEL VNR WIDE RANGE PROPORTIONER

The Viking Corporation, 5150 Beltway Dr. SE, Caledonia MI, 49316

Telephone: 269-945-9501 Technical Services: 877-384-5464 Fax: 269-818-1680 Email: techsvcs@vikingcorp.com

Visit the Viking website for the latest edition of this technical data page www.vikinggroupinc.com

7. INSTALLATION

⚠ WARNING

Adjustment of the equipment poses the risk of fatal consequences.

The wide range proportioner must not be adjusted. A security tag is placed on the plug (#8) to prevent unauthorized adjustment.

Refer to appropriate Installation Standards (i.e. NFPA, VdS, LPCB, etc.) and / or applicable FM Global Property Loss Prevention Data Sheets such as 4-12, Foam-Water Sprinkler Systems. In addition, the Authority Having Jurisdiction (AHJ) may have additional installation requirements that must be followed.

Do not alter the piping without consulting a system design representative.

Before installing a wide range proportioner, check the system design drawing to ensure the device location does not create excessive head pressure or frictional losses.

⚠ WARNING

The wide range proportioner must not be installed in dry pipework. If used in preaction, dry or deluge type systems, the wide range proportioner must be installed in the wet pipework upstream of the system control valve.

- a) Check that the tamper proof seal on bottom plug is not damaged or removed. In case of either scenario, report immediately to supplier.
- b) The wide range proportioner must be installed with the arrow pointing in the direction of the water flow.
- c) The wide range proportioner can be installed in the vertical or horizontal position.
- d) If installed in the system riser, consideration should be given to drainage as the clapper (7) acts as a partial check valve which will result in slow drainage. Use of or installation of a drain valve downstream of the wide range proportioner is advisable for faster drainage.
- e) Straight piping equal to a minimum of five (5) pipe diameters should be installed upstream and five (5) downstream of the wide range proportioner to help ensure proportioning accuracy.
- f) A check valve must be placed on the foam concentrate line and a concentrate control valve is highly recommended.
- g) A removable section of pipe should be installed between the check valve and wide range proportioner foam inlet to allow the flushing of foam concentrate after system activation.
- h) The ideal location for the wide range proportioner is level with or below the top tank discharge point and within 3 ft. (1m) of the tank.
- i) The combined total equivalent length of pipe (pipe length, plus equivalent lengths for fittings and valves), including both the water supply inlet piping and the foam concentrate discharge piping, should not exceed 65 equivalent feet (19.8 m). This will allow both pipes to be the same size as the foam liquid inlet to the wide range proportioner.
- j) The pressure drop within the piping to the bladder tank water or foam concentrate piping can be minimized by:
 1. Limiting the number of tees and elbows used
 2. Using full port valves
 3. Increasing the pipe diameter
- k) Care should be taken to ensure that the bladder tank and foam concentrate line are vented of trapped air to assist proportioning performance.



TECHNICAL DATA

MODEL VNR WIDE RANGE PROPORTIONER

The Viking Corporation, 5150 Beltway Dr. SE, Caledonia MI, 49316

Telephone: 269-945-9501 Technical Services: 877-384-5464 Fax: 269-818-1680 Email: techsvcs@vikingcorp.com

Visit the Viking website for the latest edition of this technical data page www.vikinggroupinc.com

8. OPERATION

The wide range proportioner is a modified venturi device for use in bladder tank balanced pressure type proportioning systems. As water flows through the device, it creates an area of lower pressure, referred to as the metering pressure drop. As the water flow increases through the venturi, the metering pressure drop increases, allowing more foam concentrate to enter through the sized foam orifice. The foam orifice size is specific to the foam concentrate used. A decrease in the water flow reduces the metering pressure drop, thereby reducing the foam concentrate flow.

Because the foam concentrate flow changes in direct proportion to the water flow, the wide range proportioner can accurately proportion foam concentrate over a wide range of system flow rates.

The flow rate at which the metering pressure drop is just high enough to overcome the pressure losses through the bladder tank and its piping, is called the low flow rating. The water flow rate through the wide range proportioner must be at or above its low flow rating in order to properly proportion foam concentrate.

The wide proportioner is designed to accurately proportion foam at low flow rates when a small number of sprinklers are operating.

The proportioning is accomplished by means of a variable geometry concept where the foam concentrate inlet size varies as a function of the sprinkler system's water flow rate. When water passes through the main waterway as described above, the hinged clapper (7) changes the geometry of the orifice restriction (2) thereby increasing the cross sectional area of the foam inlet. The clapper (7) and the orifice restriction (2) progressively open further as the system flow rate increases. At larger water flow rates, the water clapper (7) and the orifice restriction (2) are fully open. (Refer to **Table 3.3.1**).

9. GUARANTEE

For details of warranty, refer to Viking's current list price schedule or contact Viking directly.

10. INSPECTION, TESTS AND MAINTENANCE

Refer to respective requirements, according to the relevant standards for Inspection, Testing and Maintenance. If applicable, refer to FM Global Property Loss Prevention Datasheet 4-12 for specific test and commissioning criteria. In addition, the "Authority Having Jurisdiction" (AHJ) may have additional maintenance, testing and inspection requirements that must be followed.

NOTICE

The owner is responsible for maintaining the fire protection system and devices in proper operating condition.



WARNING

Any system maintenance or testing that involves placing a control valve or detection system out of service may eliminate the fire protection capabilities of that system. Prior to proceeding, notify all Authorities Having Jurisdiction. Consideration should be given to employment of a fire patrol in the affected area.

11. DISPOSAL

At end of use the product described here should be disposed of via the national recycling system.

12. ACCESSORIES AND SPARE PARTS

This device is not field repairable and there are no spare parts.

13. DECLARATION OF CONFORMITY

If required, contact the appropriate Viking sales office in **Section 5 Availability** for further assistance.



TECHNICAL DATA

**VERTICAL AND HORIZONTAL
BLADDER TANKS MODEL VFT
ASME Sec.VIII Div.1 - U-1A**

The Viking Corporation, 210 N Industrial Park Drive, Hastings MI 49058
Telephone: 269-945-9501 Technical Services: 877-384-5464 Fax: 269-818-1680 Email: techsvcs@vikingcorp.com
Visit the Viking website for the latest edition of this technical data page.

1. GENERAL DESCRIPTION

The bladder tank is a carbon steel pressure vessel containing an elastomeric bladder between the water and foam concentrate. The bladder permits water pressure to be transferred to the foam concentrate without the two fluids mixing together.

This Technical Data Page is intended for trained experts. It contains basic information needed to use the product described. Legally binding is the product operation and maintenance manual which must be observed.

For further information, please contact the appropriate sales office in Section 5 Availability or refer to the technical documentation.

The contents of this publication are subject to modifications without notice.



Photographs are for illustration purposes only. Refer to drawings for actual design details.

2. LISTINGS AND APPROVALS

The bladder tank is FM Approved and/or UL Listed as part of a fire extinguishing system combining designated foam concentrates, specific proportioning equipment, and discharge devices. Approved and Listed system components can be found at www.approvalguide.com and <https://iq.ulprospector.com>



FM Approved – Low Expansion Foam Systems (FM5130)



UL Listed – Guide GFGV.EX27255 & GHXV.EX5002 (UL162)

Constructed according to ASME Boiler and Pressure Vessel Code (BPVC) Sec.VIII Div.1 with U-1A (“U” Stamp certification process.



CE marked according to the PED Directive 2014/68/EU (Europe Only)

NOTE: Other international approval certificates may be available upon request.

“SFFF compatible” refers to this product as being part of a SFFF Foam system that has been tested to recognized standards. Not all configurations are available. Please consult technical data and/or the Approval/Listing for usage requirements.



WARNING: Cancer and Reproductive Harm-
www.P65Warnings.ca.gov



TECHNICAL DATA

**VERTICAL AND HORIZONTAL
BLADDER TANKS MODEL VFT
ASME Sec.VIII Div.1 - U-1A**

The Viking Corporation, 210 N Industrial Park Drive, Hastings MI 49058
Telephone: 269-945-9501 Technical Services: 877-384-5464 Fax: 269-818-1680 Email: techsvcs@vikingcorp.com
Visit the Viking website for the latest edition of this technical data page.

3. TECHNICAL DATA

3.1 Construction Features

- Vertical tanks on legs or horizontal tanks on saddles
- Legs and saddles are provided with mounting brackets/holes.
- Approved system design pressure of 175 PSI (12.1 bar) or 232 PSI (16.0 bar)
- 100% pressure tested according to the applied design code
- Shell and heads in ASME SA-516 Gr.70
- Lockable corrosion resistant brass tank trim/service ball valves (UL Listed / FM Approved)
- Inspection flange available on left or right side of horizontal tanks (left as standard)
- Machine welded circumferential and longitudinal seams for maximum quality and durability
- Welded lifting lugs to facilitate safe handling operations
- Earth lug for electrical safety
- Safety thermal valve for water side of bladder to prevent slow overpressure and relieve thermal fluctuations
- Bladder equipped with cast rubber caps to ensure water & foam integrity under constant pressure
- Bladder specifically tested for compatibility with foams shown in FM Approval and UL Listing
- Oversized to permit concentrate thermal expansion (volume expansion allowance)
- Tank equipped with inside protection at any opening to ensure no damage to the bladder
- Internal PVC foam concentrate distribution pipe ensures optimal foam concentrate usage
- Internal water distribution channel to equalize the water pressure everywhere avoiding damage to the bladder and to drain the tank during service and maintenance
- Nameplate holder to avoid undetected corrosion on the tank's shell behind the plate
- Sight Tube level indicator
- External epoxy zinc rich primer with aliphatic polyurethane finish tested by FM and UL for corrosive atmosphere (salt fog)

3.2 Standard Materials

Table 3.2.1 - Standard Materials	
Tank shell and heads:	ASME SA-516 Gr. 70
Bladder:	Reinforced NBR and EPDM
Trim valves:	Brass
Safety thermal relief valve:	Brass
Level indicator:	Sight Tube: PVC
Paint:	Epoxy zinc rich primer with aliphatic polyurethane finish
Standard colour:	Flame Red RAL3000
Connection:	Grooved (2.5" available with 73.0 or 76.1 mm - specify upon ordering)

3.3 Standard Design Specifications

Table 3.3.1 - Standard Design Specifications	
Design pressure:	175 PSI / 12.1 bar (1.2MPa) or 232 PSI /16.0 bar (1.6MPa)
Operating temperature range*:	35°F to 120°F (1.7°C to 49°C)
Capacity:	See tables
Empty weight:	See tables
Proportioning range:	See Ratio Controller data sheet
(*) Refer to the appropriate proportioner for foam concentrate being used.	



TECHNICAL DATA

**VERTICAL AND HORIZONTAL
BLADDER TANKS MODEL VFT
ASME Sec.VIII Div.1 - U-1A**

The Viking Corporation, 210 N Industrial Park Drive, Hastings MI 49058

Telephone: 269-945-9501 Technical Services: 877-384-5464 Fax: 269-818-1680 Email: techsvcs@vikingcorp.com

Visit the Viking website for the latest edition of this technical data page.

3.4 Ordering Information

The following information is provided to ensure that the correct design requirements are provided during the order and manufacturing process. Mandatory information is required in every case. Optional information is required in case of special project or specification requirements.

Table 3.4.1: Ordering Information			
	Ref	Criteria	Option
Mandatory Information (required for quote/order processing)	1a	Configuration	a) Vertical b) Horizontal
	1b	Capacity	a) 25 to 4000 US Gallons Vertical b) 50 to 5250 US Gallons Horizontal (see tables for available sizes)
	1c	Design Code	ASME Bolier and Pressure Vessel (BPVC) Code with U-1A Manufacturer Data Report
	1d	Standby Pressure Rating	a) 175 PSI / 12.1 bar (1.2 MPa) b) 232 PSI /16.0 bar (1.6 MPa)
	1e	Inspection Flange	a) Left (Standard) b) Right (required for Horizontal Tanks only)
	1g	Language	Select Bladder Tank Manual Language (see Table 12.1.2)
	Optional	2a	Design Temperature
2b		Corrosion Allowance	Contact technical department
2c		Radiographic Test Report (*)	Contact technical department
2d		Liquid Penetrant Test Report (*)	Contact technical department
Pre-Assembled with Ratio Controller	3a	Ratio Controller Size(s)	2", 2.5", 3", 4", 6", 8"
	3b	Direction of Flow	a) Left to right b) Right to left (direction of flow as you face the tank)
	3c	Water Line Piping	Carbon Steel
	3d	Foam Line Piping	a) Brass b) Stainless Steel
	3e**	Foam Concentrate Type(**)	a) 3% xMAX b) Viking ARK 3% c) Viking USP 3%
	3f	Concentrate Control Valve	Viking Halar CCV (FM UL) or Hydraulic Ball Valve
(*) With additional cost			
(**) These foam concentrates have been tested for bladder compatibility as per UL162 and/or FM5130. The long term compatibility of other foams concentrates cannot be verified.			

INFORMATION

Some of the available options may be not covered by the UL Listing or FM Approval. Please always make reference to the appropriate approval directory or guides or contact the appropriate sales office in Section 5 Availability for further assistance.



TECHNICAL DATA

**VERTICAL AND HORIZONTAL
BLADDER TANKS MODEL VFT
ASME Sec.VIII Div.1 - U-1A**

The Viking Corporation, 210 N Industrial Park Drive, Hastings MI 49058

Telephone: 269-945-9501 Technical Services: 877-384-5464 Fax: 269-818-1680 Email: techsvcs@vikingcorp.com

Visit the Viking website for the latest edition of this technical data page.

4. SCOPE OF DELIVERY

Ensure that all components are complete and in good condition.

The bladder tank is supplied in or on a suitable wooden pallet skid or shipping crate in the horizontal position.

All bladder tanks have lifting lugs to allow safe maneuverability on site.

Tank is supplied empty with pre-installed bladder.

Small trim valves and contents level device are supplied pre-assembled to the tank as standard.

Safety thermal relief valve supplied as standard, unmounted from tank. UV marked Safety Valve according to ASME BPVC Sec. VIII Div.1 available for an additional cost.

Anchor fixing bolts are not part of our supply scope.

Table 4.1.1 - Documentation

Standard Documentation	Optional Documentation *
Warranty Certificate	Dimensional Drawings
PED Declaration or Conformity	Material Certificates according to ASME Code Specifications
Safety Thermal Relief Valve Declaration of Conformity	Certificate of Conformity Type 2.1 to EN10204
Hydrostatic Pressure Test Certificate	Design Structural Calculations
Bladder Pneumatic Test Certificate	Spot or Full Radiographic Examination with Report (when not mandatorily required by design parameters)
Painting Inspection Certificate	Spare Parts List
Final Inspection Certificate	Copy of Procedure Qualification Record (PQR) and Welding Procedure Specification (WPS) according to tank construction code
Operating, Filling and Maintenance Manual (English)	Operating, Filling and Maintenance Manual (Language)
Manufacturer Data Report Form U-1A	

(*) Contact the sales office listed in section 5 for further information and price.

5. AVAILABILITY

The Viking Corporation, 210 N. Industrial Park Drive, Hastings, Michigan 49058, Toll free phone: (800) 968-9501

6. PRODUCT VARIANTS

6.1 Options

- Flanged connections (ANSI or PN16)
- Special coatings for salt-water applications or harsh environmental conditions
- Nameplate in corrosion resistant material
- Increased wall thickness for corrosion allowance
- Internal coatings such as epoxy tar
- 232 PSI /16.0 bar (1.6 MPa) design pressure rating with UL Listing and FM Approval
- Other design pressure and seismic ratings
- Ladders | Work Platform | Sunshield
- Full bladder tank stainless steel construction
- Heat tracing and/or insulation
- Bladder tank pre-installed on base frame or containerized to customer requirements
- Various colors and painting cycles with UL Listing and FM Approval (120-300 microns)
- Nondestructive examinations
- Factory acceptance test, notified body or third party inspections
- Special sea freight and fumigated packaging
- UV certified Safety Valve according to ASME BPVC Code Sec.VIII Div.1

Please contact us for further details, pricing and availability

INFORMATION

Some of the available options may be not covered by the UL Listing or FM Approval. Please always make reference to the appropriate approval directory or guides or contact us for further assistance.



TECHNICAL DATA

VERTICAL AND HORIZONTAL BLADDER TANKS MODEL VFT ASME Sec.VIII Div.1 - U-1A

The Viking Corporation, 210 N Industrial Park Drive, Hastings MI 49058
 Telephone: 269-945-9501 Technical Services: 877-384-5464 Fax: 269-818-1680 Email: techsvcs@vikingcorp.com
 Visit the Viking website for the latest edition of this technical data page.

6.2 General bladder tank layout and P&ID

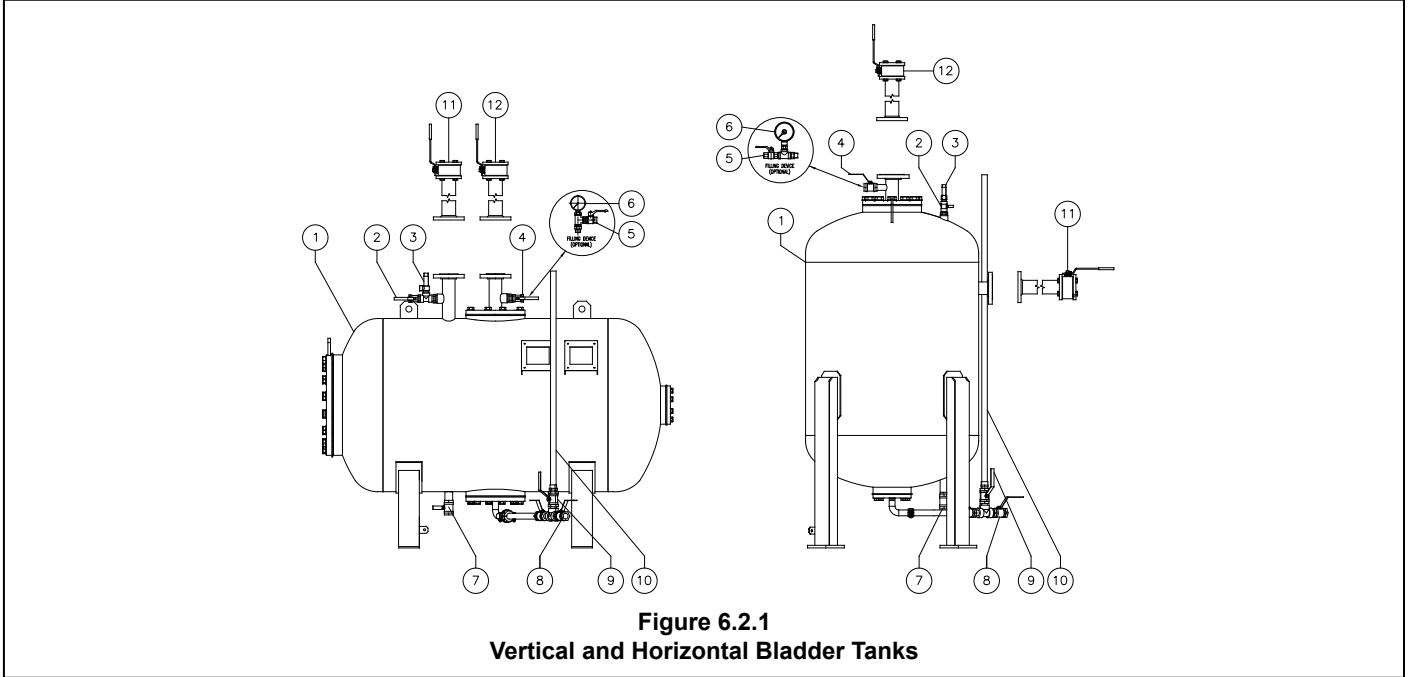

Figure 6.2.1
Vertical and Horizontal Bladder Tanks

Table 6.2.2 - General Bladder Tank Layout and P&ID

Item	Description	Item	Description
1	Bladder Tank	7	Water Filling/Drain Valve (NPT)
2	Water Vent Valve (NPT)	8	Foam Concentrate Filling/Drain Valve (NPT)
3	Safety Thermal Relief Valve	9	Concentrate Level Indicator Drain Valve
4	Foam Concentrate Vent Valve (NPT)	10	Concentrate Level Indicator
5	Filling Vent Valve (Optional)	11	Water Shut Off Valve (to be ordered separately)
6	Filling Pressure Gauge 1-10 kpa (Optional)	12	Foam Concentrate Shut Off Valve (to be ordered separately)

Note: Item 10 shown with Sight Tube. Level Gauge also available and connected at position 10.

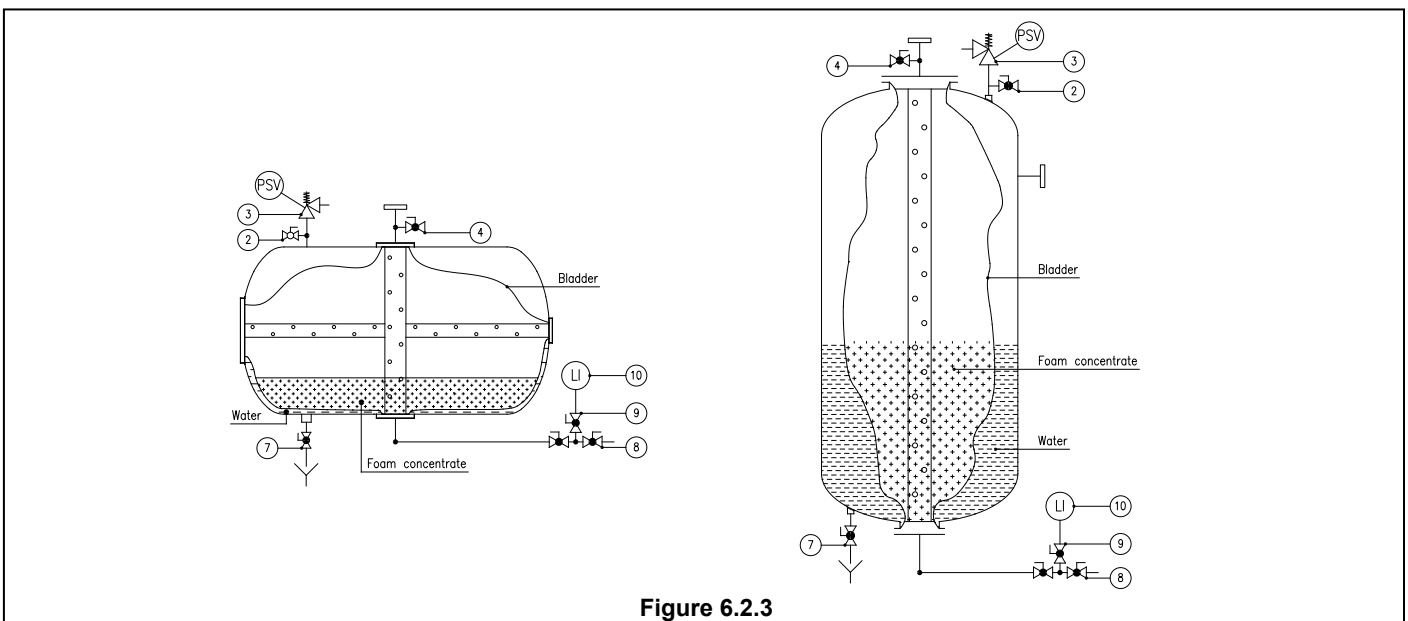

Figure 6.2.3



TECHNICAL DATA

**VERTICAL AND HORIZONTAL
BLADDER TANKS MODEL VFT
ASME Sec.VIII Div.1 - U-1A**

The Viking Corporation, 210 N Industrial Park Drive, Hastings MI 49058
 Telephone: 269-945-9501 Technical Services: 877-384-5464 Fax: 269-818-1680 Email: techsvcs@vikingcorp.com
 Visit the Viking website for the latest edition of this technical data page.

6.3 Dimensions

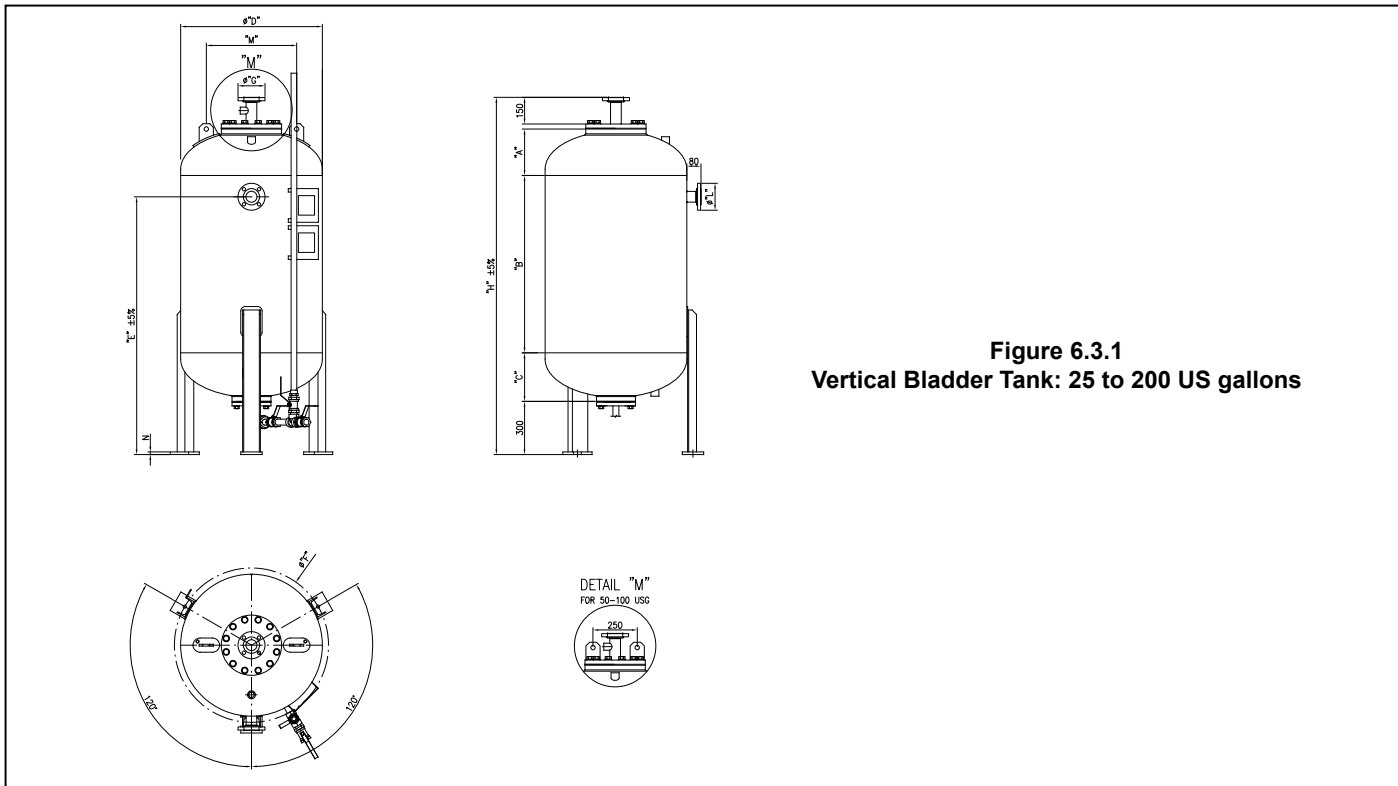

Figure 6.3.1
Vertical Bladder Tank: 25 to 200 US gallons

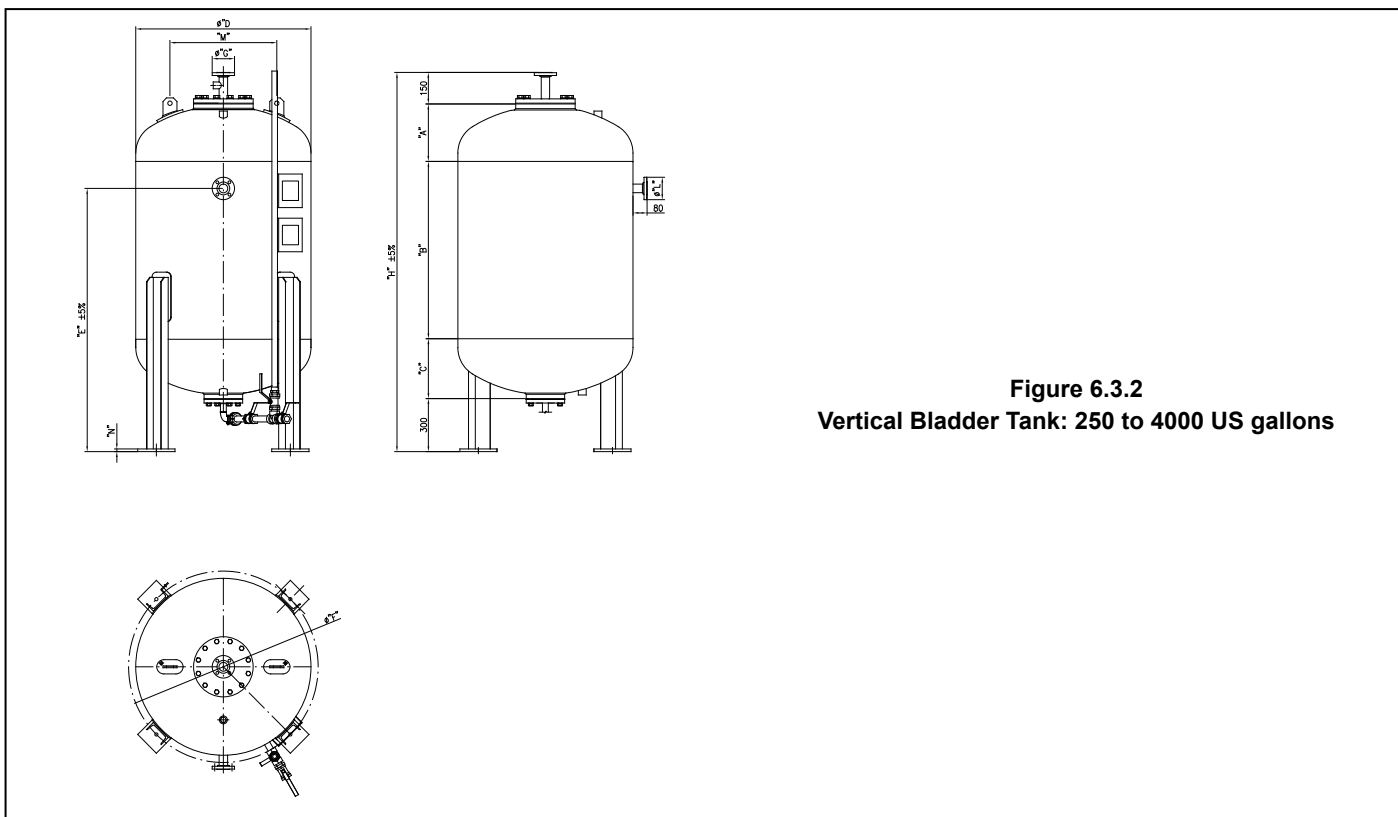

Figure 6.3.2
Vertical Bladder Tank: 250 to 4000 US gallons



TECHNICAL DATA

VERTICAL AND HORIZONTAL BLADDER TANKS MODEL VFT ASME Sec.VIII Div.1 - U-1A

The Viking Corporation, 210 N Industrial Park Drive, Hastings MI 49058
 Telephone: 269-945-9501 Technical Services: 877-384-5464 Fax: 269-818-1680 Email: techsvcs@vikingcorp.com
 Visit www.vikinggroupinc.com for the latest edition of this Technical Data page.

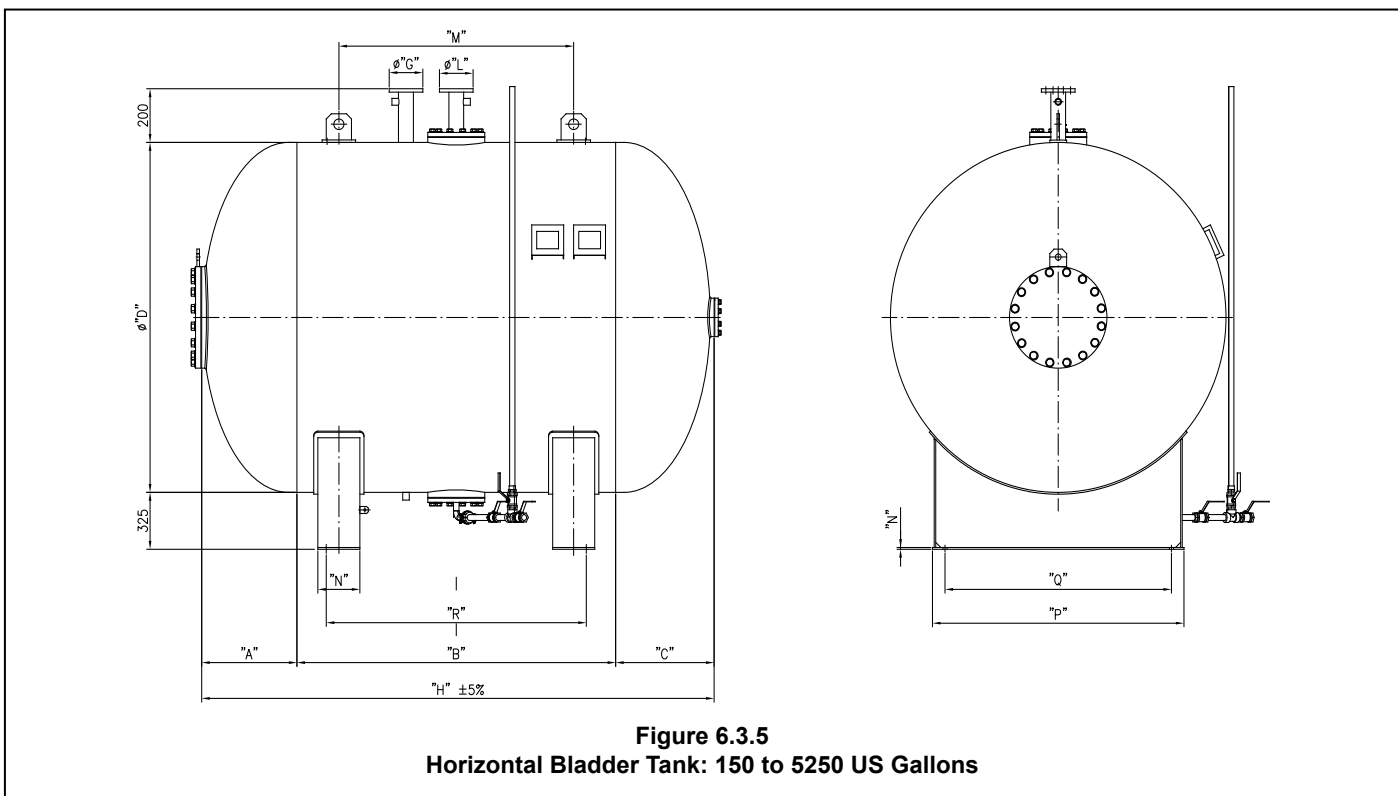
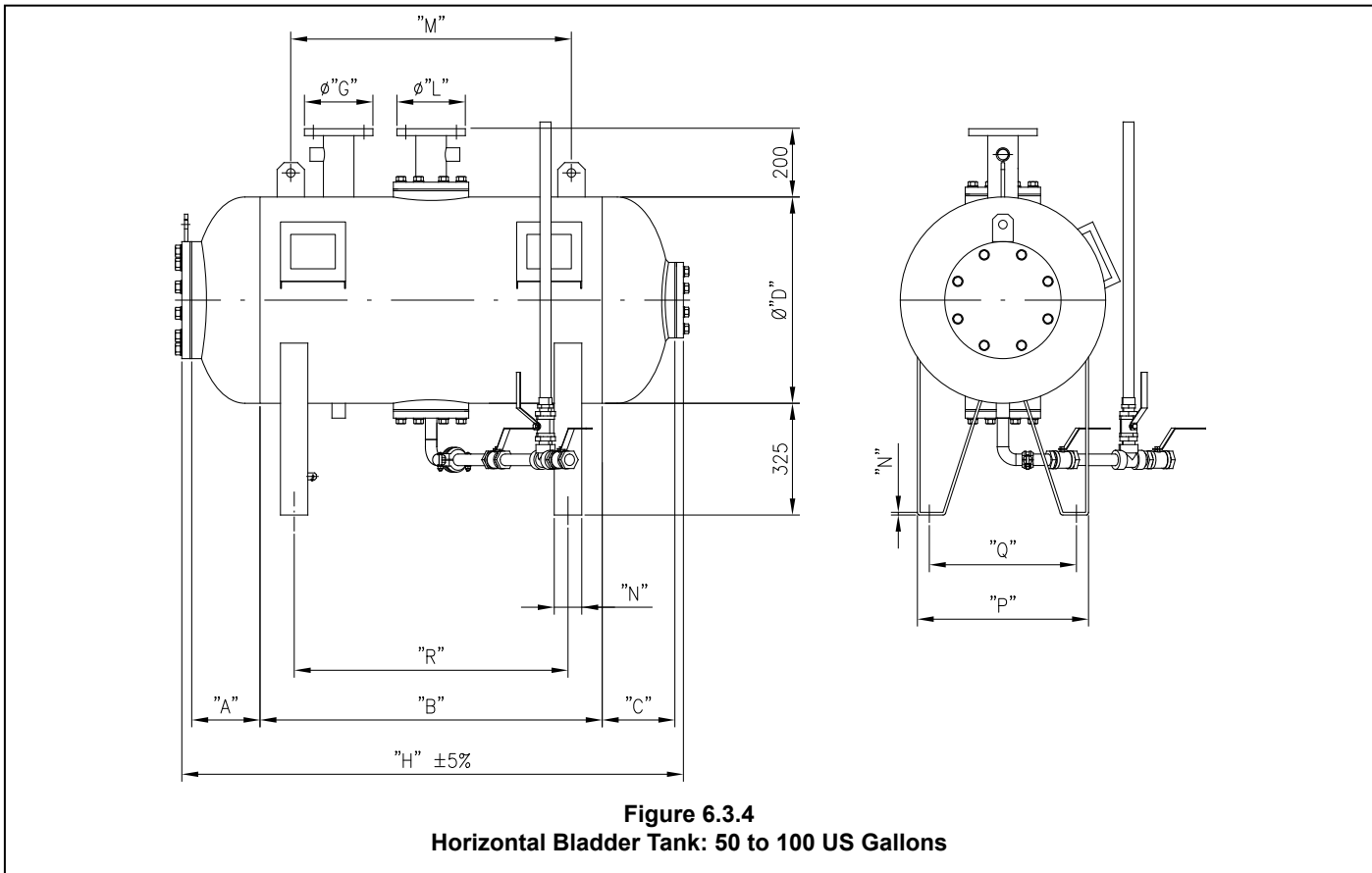



TECHNICAL DATA

VERTICAL AND HORIZONTAL BLADDER TANKS MODEL VFT ASME Sec.VIII Div.1 - U-1A

The Viking Corporation, 210 N Industrial Park Drive, Hastings MI 49058
 Telephone: 269-945-9501 Technical Services: 877-384-5464 Fax: 269-818-1680 Email: techsvcs@vikingcorp.com
 Visit www.vikinggroupinc.com for the latest edition of this Technical Data page.

Table 6.3.6 - Horizontal Bladder Tank Dimensions (ASME Sec VIII Design Code) (cont.)

Bladder Tank : ASME Sec VIII Design Code		Capacity		Weight		A	B	C	ØD	ØG	H	ØL	M	N	O	P	Q	R
175 PSI /12.1 bar	232 PSI / 16.0 bar	USG	Litres	LBS	KG	inch	inch	inch	inch	inch	inch	inch	inch	inch	inch	inch	inch	inch
						mm	mm	mm	mm	mm	mm	mm	mm	mm	mm	mm	mm	mm
VFTH3000U	VFTH3000U-16	3000	11356	8177	3704	22.3	122.0	23.1	78.7	3	167.4	3	102.4	0.4	5.9	59.1	53.1	108.3
						566	3100	586	2000	80	4252	80	2600	10	150	1500	1350	2750
VFTH3200U	VFTH3200U-16	3200	12113	8618	3904	22.3	133.9	23.1	78.7	3	179.2	3	114.2	0.4	5.9	59.1	53.1	120.1
						566	3400	586	2000	80	4552	80	2900	10	150	1500	1350	3050
VFTH3400U	VFTH3400U-16	3400	12870	8925	4043	22.3	141.7	23.1	78.7	3	187.1	3	126.0	0.4	5.9	59.1	53.1	131.9
						566	3600	586	2000	80	4752	80	3200	10	150	1500	1350	3350
VFTH3600U	VFTH3600U-16	3600	13627	9311	4218	22.3	151.6	23.1	78.7	3	196.9	3	139.8	0.4	5.9	59.1	53.1	145.7
						566	3850	586	2000	80	5002	80	3550	10	150	1500	1350	3700
VFTH3800U	VFTH3800U-16	3800	14384	9631	4363	22.3	159.4	23.1	78.7	3	204.8	3	139.8	0.4	5.9	59.1	53.1	145.7
						566	4050	586	2000	80	5202	80	3550	10	150	1500	1350	3700
VFTH4000U	VFTH4000U-16	4000	15141	10170	4607	22.3	173.2	23.1	78.7	3	218.6	3	139.8	0.4	5.9	59.1	53.1	145.7
						566	4400	586	2000	80	5552	80	3550	10	150	1500	1350	3700
VFTH4250U	VFTH4250U-16	4250	16088	10631	4816	22.3	185.0	23.1	78.7	3	230.4	3	139.8	0.4	5.9	59.1	53.1	145.7
						566	4700	586	2000	80	5852	80	3550	10	150	1500	1350	3700
VFTH4500U	VFTH4500U-16	4500	17034	11095	5026	22.3	196.9	23.1	78.7	3	242.2	3	139.8	0.4	5.9	59.1	53.1	151.6
						566	5000	586	2000	80	6152	80	3550	10	150	1500	1350	3850
VFTH4750U	VFTH4750U-16	4750	17980	11634	5270	22.3	210.6	23.1	78.7	3	256.0	3	139.8	0.4	5.9	59.1	53.1	151.6
						566	5350	586	2000	80	6502	80	3550	10	150	1500	1350	3850
VFTH5000U	VFTH5000U-16	5000	18927	12097	5480	22.3	222.4	23.1	78.7	3	267.8	3	139.8	0.4	5.9	59.1	53.1	159.4
						566	5650	586	2000	80	6802	80	3550	10	150	1500	1350	4050
VFTH5250U	VFTH5250U-16	5250	19873	12636	5724	22.3	236.2	23.1	78.7	3	281.6	3	139.8	0.4	5.9	59.1	53.1	159.4
						566	6000	586	2000	80	7152	80	3550	10	150	1500	1350	4050

7. INSTALLATION

Refer to appropriate Installation Standards (i.e. NFPA, VdS, LPCB, etc.) and / or FM applicable FM Global Property Loss Prevention Data Sheets such as 4-12, Foam-Water Sprinkler Systems.

The Installation, Operation and Maintenance Bladder Tank Manual shall also be referenced.

NOTICE

When designing a bladder tank into your fire protection system, please give consideration to future maintenance activities. Ensure that adequate clearance above a vertical bladder tank or at the inspection flange end of a horizontal tank is allowed. For further guidance contact us.

8. OPERATION

1. Foam concentrate is stored inside the bladder. When used in conjunction with a Ratio Controller it proportions foam concentrate accurately into the water stream.
2. During system activation, the outer side of the bladder is pressurized by the system water supply which forces foam concentrate to the proportioner or a ratio controller.
3. Simultaneously, as water flows through the venturi area of the wide range proportioner or ratio controller, a metered pressure drop draws foam concentrate into the system water stream creating a foam solution mixed to the appropriate ratios.
4. The foam solution flows through the system pipework and out of any open sprinklers, nozzles or other discharge devices.
5. As the foam concentrate continues to flow from the inside of the bladder, system water enters the bladder tank on the outside of the bladder keeping a balanced pressure system.

9. GUARANTEE

For details of warranty, refer to Viking's current list price schedule or contact Viking directly.



TECHNICAL DATA

**VERTICAL AND HORIZONTAL
BLADDER TANKS MODEL VFT
ASME Sec.VIII Div.1 - U-1A**

The Viking Corporation, 210 N Industrial Park Drive, Hastings MI 49058
Telephone: 269-945-9501 Technical Services: 877-384-5464 Fax: 269-818-1680 Email: techsvcs@vikingcorp.com
Visit the Viking website for the latest edition of this technical data page.

10. INSPECTION, TESTS AND MAINTENANCE

⚠ WARNING

Any system maintenance or testing that involves placing a control valve or detection system out of service may eliminate the fire protection capabilities of that system. Prior to proceeding, notify all Authorities Having Jurisdiction. Consideration should be given to employment of a fire patrol in the affected area.

Refer to respective requirements, according to the relevant standards for Inspection, Testing and Maintenance.
If applicable, refer to FM Global Property Loss Prevention Datasheet 4-12 for specific test and commissioning criteria.
In addition, the "Authority Having Jurisdiction" (AHJ) may have additional maintenance, testing and inspection requirements that must be followed.

11. DISPOSAL

At end of use the product described here should be disposed of via the national recycling system.
Upon request the manufacturer can take back and properly dispose of the electrical equipment and electronic devices.

12. ACCESSORIES AND SPARE PARTS

Contact the appropriate sales office in Section 5 Availability for further assistance.

Table 12.1.1 - Optional / Standard Spare Parts

Description	Material	Connection	Part Number	
			175 PSI (12 bar) Tanks	16 bar Tanks
Safety Thermal Relief Valve	Brass	1/2"	B10C12.1	B10C16
ASME Safety Valve	Carbon Steel	3/4"	EUV34CS-12.1	EUV34CS-16.0
ASME Safety Valve	Stainless Steel 316	3/4"	EUV34SS-12.1	EUV34SS-16.0
Filling Device & KPA Gauge	Carbon Steel	1"	FILLDEVICE	
Replacement Bladder	Various	Contact us with tank serial number		
Sight tube replacement kit	Various	Contact us with tank serial number		

Table 12.1.2 - Bladder Tank Manual

Language	Part Number	Language	Part Number
English	F032216-EN	Dutch	F032216-NL
German	F032216-DE	Polish	F032216-PL
Spanish	F032216-ES	Swedish	F032216-SV
French	F032216-FR	Turkish	F032216-TR
Italian	F032216-IT	--	--

13. DECLARATION OF CONFORMITY

If required, contact the appropriate sales office in **Section 5 Availability** for further assistance.



TECHNICAL DATA

**VIKING USP SFFF
FLUORINE FREE
FOAM CONCENTRATE**

The Viking Corporation, 210 N Industrial Park Drive, Hastings MI 49058
 Telephone: 269-945-9501 Technical Services: 877-384-5464 Fax: 269-818-1680 Email: techsvcs@vikingcorp.com
 Visit the Viking website for the latest edition of this technical data page www.vikinggroupinc.com

1. DESCRIPTION

The Viking USP concentrate concentrate is specially designed and tested to be an effective fluorine free fire protection system foam alternative. This concentrate is approved for use with fresh water when proportioned at 3%.

Features:

- New generation hydrocarbon risk fluorine free foam (SFFF)
- For Class A & B fires
- 100% Biodegradable

2. LISTINGS AND APPROVALS

This product must be used in accordance with the certifications listed below. Approved and listed system components can be found at www.approvalguide.com and <https://iq.ulprospector.com>



FM Approved

FM Approved Refer to the FM Approval guide for systems and devices that are approved for use with this concentrate. Refer to the system and device data sheets from Viking, NFPA, FM Global Property Loss Prevention Data Sheets, and relevant local codes and/or standards for correct system design. FM Approval of the foam extinguishing system is contingent upon the design, installation, testing and maintenance performed in accordance with NFPA and/or FM Global Property Loss Prevention Data Sheet 4-12, Foam/ Water Sprinkler Systems.



UL Listed – GFGV.EX27255

Underwriters Laboratories, UL 162 7th Edition Refer to the UL Listing for systems and devices that are approved for use with this concentrate. Refer to the system and device data sheets from Viking, NFPA, and relevant local codes and/or standards for correct system design.

“SFFF compatible” refers to this product as being part of a SFFF Foam system that has been tested to recognized standards. Not all configurations are available. Please consult technical data and/or the approval/ listing for usage requirements.

The following additional approvals are in the name of the manufacturer.

- EN 1568 Part 1 / EN 1568 Part 2 / EN 1568 part 3, Class 1A fresh water*
- ICAO Level B*
- GESIP approved for hydrocarbon fuels*
- IMO 1312*
- MED Module B and D*
- Boeing Specification Support Standard BSS 7432*

3. TECHNICAL DATA

Physical Data

Appearance.....	Clear to yellowish liquid
Specific gravity at 68 °F (20 °C)	1.04 +/- 0.01 g/ml
Viscosity	Pseudoplastic*
pH.....	6.5 to 8.5
Freezing point	12 °F (-11 °C)
Recommended storage temperature	32 °F to 131 °F (0 to 55°C)
FM Approved storage temperature	35 °F to 120 °F (1.7 to 49 °C)
Suspended sediment (v/v)	Less than 0.2%

*see detailed viscosity data in section 16

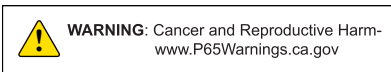



TECHNICAL DATA

VIKING USP SFFF FLUORINE FREE FOAM CONCENTRATE

The Viking Corporation, 210 N Industrial Park Drive, Hastings MI 49058
 Telephone: 269-945-9501 Technical Services: 877-384-5464 Fax: 269-818-1680 Email: techsvcs@vikingcorp.com
 Visit the Viking website for the latest edition of this technical data page www.vikinggroupinc.com

TABLE 1: ORDERING INFORMATION

Volume	Packaging	Part Number	Approximate Shipping Weight*		Dimensions* In (mm)		Sales Region
			Lbs.	Kg	Inches	mm	
25 Litres	Can	V-SFFFUSP/25	59**	26.7**	11x10x17	295x260x441	EMEA/APAC
200 Litres	Drum	V-SFFFUSP/200	469**	212.5**	23x23x37	581x581x935	EMEA/APAC
1000 Litres	IBC Tote	V-SFFFUSP/1000	2381	1080	47x39x45	1200x1000x1150	EMEA/APAC
6.5 US Gallons	Can	F21720-6.5	62**	28**	11x10x29	295x260x737	AMERICAS
55 US Gallons	Drum	F21720-55	487**	220.7**	23x23x37	581x581x935	AMERICAS
265 US Gallons	IBC Tote	F21720-265	2389	1083.6	47x39x45	1200x1000x1150	AMERICAS
Bulk	Bulk tanker deliveries available by special request. Contact Viking for availability.						
*Shipping weight and dimensions are approximate. **Weight does not include pallet.							

4. ENVIRONMENTAL IMPACT

The Viking USP concentrate is formulated using specially selected raw materials for their fire performance and their environmental profile. The product contains no intentionally added fluorinated surfactants, polymers, and other organohalogens. The Viking USP concentrate is biodegradable and contains NO PFOS NOR PFOA. The handling of foam concentrate or foam solution spills should be in accordance with local regulations. Sewage systems should have no processing issues with foam solution based on the Viking USP concentrate but local sewage operators should be consulted in this respect. The Viking USP concentrate is formulated without the use of fluorinated surfactants. Full details can be found in the Safety Data Sheet (SDS).

5. APPLICATION

The Viking USP concentrate is intended for use on class B hydrocarbon fuel fires such as oil, diesel, aviation fuel and gasoline. It is also suitable for class A fires such as wood, paper, textiles etc. The Viking USP concentrate is especially suited whenever a fluorine-free alternative with high fire performance is required. The Viking USP concentrate is tested for use in sprinkler systems. Refer to listing or approval for further details of approved use combinations.

Note: Not for use as a premixed solution.

6. PROPORTIONING

The Viking USP concentrate can be proportioned at the correct dilution using conventional equipment like bladder tanks and proportioners. Refer to the FM Approval or UL Listing for proportioning equipment approved for use with this concentrate.

7. FIRE PERFORMANCE & FOAMING

The fire performance of this product has been measured and documented according to "International Approvals" stated in this document. The foaming properties are depending on equipment used and other variables such as water and ambient temperatures.

8. SPRINKLER APPLICATION

Sprinkler applications are especially challenging for any foam due to the low operating pressure and the very low expansion reached. Applying foam through a sprinkler is a forceful application method and requires foam that can handle direct application and partial submersion into the fuel without losing its fire performance and burnback resistance. Foams that shall be regarded as suitable for sprinkler applications shall also be able to withstand limited time of water deluge directly onto the foam blanket and still maintain the burnback properties. The Viking USP concentrate has passed above described tests showing very good extinguishing and burnback properties. Refer to the FM Approval Guide or UL Product iQ for acceptable system configurations used with this concentrate and specific sprinkler SINS and their associated minimum application densities.



TECHNICAL DATA

VIKING USP SFFF FLUORINE FREE FOAM CONCENTRATE

The Viking Corporation, 210 N Industrial Park Drive, Hastings MI 49058

Telephone: 269-945-9501 Technical Services: 877-384-5464 Fax: 269-818-1680 Email: techsvcs@vikingcorp.com

Visit the Viking website for the latest edition of this technical data page www.vikinggroupinc.com

9. STORAGE / SHELF LIFE

Stored in original unbroken packaging the product will have a long shelf life. Shelf life in excess of 10 years will be found in temperate climates. As with all foams, shelf life will be dependent on storage temperatures and conditions.

10. SCOPE OF DELIVERY

We supply this product in 25 litre and 6.5 US gallon cans, 200 litre and 55 US gallon drums, 1000 litre and 265 US gallon IBC containers and in bulk on special request.

11. INSPECTIONS, TESTS AND MAINTENANCE

The foam concentrate should be tested annually. Refer to respective requirements, according to the relevant codes and/or standards for Inspection, Testing and Maintenance. If applicable, refer to FM Global Property Loss Prevention Datasheet 4-12 for specific test and commissioning criteria. In addition, the "Authority Having Jurisdiction" (AHJ) may have additional maintenance, testing and inspection requirements that must be followed

12. DISPOSAL



At the end of use the product packaging should be disposed of via the national recycling system. Some IBC Tote containers maybe part of a national collection scheme. Details will be attached to the IBC Tote if this service is available. Foam Concentrate should be disposed of according to local regulations.

13. AVAILABILITY

The product is available directly from Viking and official distributors only.

Americas:

The Viking Corporation
5150 Beltway SE
Caledonia, MI 49316
Tel.: (800) 968-9501
Fax: 269-818-1680
Technical Services: 1-877-384-5464
techsvcs@vikingcorp.com

EMEA:

Viking S.A.
21, Z.I. Haneboesch
L-4562 Differdange / Niederkorn
Tel.: +352 58 37 37 - 1
Fax: +352 58 37 36
vikinglux@viking-emea.com

Asia Pacific (APAC) Main Office:

The Viking Corporation (Far East) Pte. Ltd.
69 Tuas View Square
Westlink Techpark, Singapore 637621
Tel: (+65) 6 278 4061
Fax: (+65) 6 278 4609
vikingAPAC@vikingcorp.com

14. GUARANTEE

For details of warranty, refer to Viking's current list price schedule or contact Viking directly.

15. COMPATIBILITY

Contact Viking with questions regarding the compatibility of this product.



TECHNICAL DATA

**VIKING USP SFFF
FLUORINE FREE
FOAM CONCENTRATE**

The Viking Corporation, 210 N Industrial Park Drive, Hastings MI 49058
 Telephone: 269-945-9501 Technical Services: 877-384-5464 Fax: 269-818-1680 Email: techsvcs@vikingcorp.com
 Visit the Viking website for the latest edition of this technical data page www.vikinggroupinc.com

16. VISCOSITY

The viscosity flow curves are determined by Brookfield RST rheometer from low to high shear rates. The viscosity curves below are determined by calculating the average value of at least 8 different measurements and add a safety margin of three standard deviations to the average. The viscosity curves are determined for 68 °F and 41 °F (20 °C and 5 °C). In the table below the kinematic viscosity (mm²/s) is calculated as dynamic viscosity (mPa·s) divided by the specific gravity of the concentrate.

TABLE 2: Viscosity Information					
RPM	Shear Rate (s ⁻¹)	Dynamic Viscosity (mPa/s)		Kinetic Viscosity (mm ² /s)	
		68 °F (20 °C)	41 °F (5 °C)	68 °F (20 °C)	41 °F (5 °C)
5	10.7	3793	3716	3647	3573
10	21.5	1948	1921	1873	1847
25	53.7	910	916	875	881
50	107.4	541	531	521	510
100	214.8	328	325	316	312
175	375.0	224	229	215	220
250	537.0	176	189	169	182
500	1074.0	139	158	134	152
750	1611.0	86	99	82	96
1000	2148.0	70	83	67	80
1300	2792.2	91	128	88	123

Viscosity vs Shear Rate

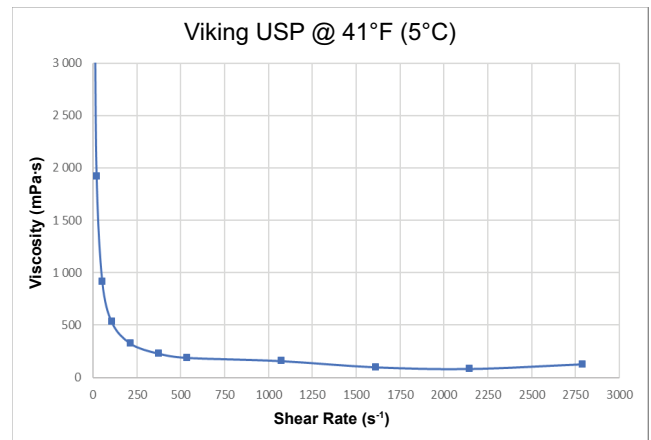
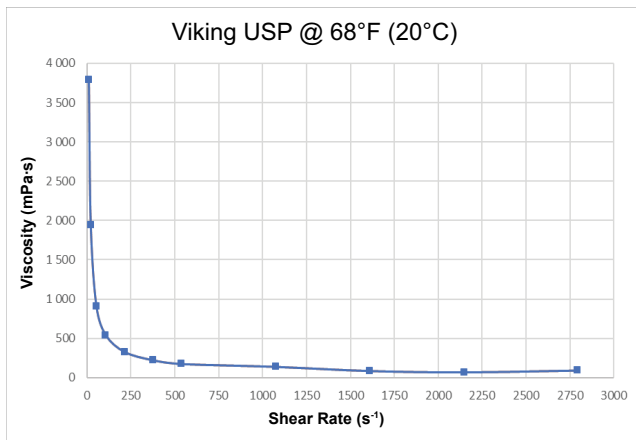



TECHNICAL DATA

VIKING ARK SFFF FLUORINE FREE FOAM CONCENTRATE

The Viking Corporation, 210 N Industrial Park Drive, Hastings MI 49058

Telephone: 269-945-9501 Technical Services: 877-384-5464 Fax: 269-818-1680 Email: techsvcs@vikingcorp.com

Visit the Viking website for the latest edition of this technical data page.

1. DESCRIPTION

Viking ARK concentrate is specially designed and tested to be an effective fluorine free fire protection system foam alternative. This concentrate is approved for use with fresh water when proportioned at 3%.

Features:

- New Generation alcohol resistant fluorine free foam (SFFF)
- For Class A & B fires

2. LISTINGS AND APPROVALS

This product must be used in accordance with the certifications listed below.

FM Approved



Refer to the FM Approval guide for systems and devices that are approved for use with this concentrate. Refer to the system and device data sheets from Viking, NFPA 11, FM Global Property Loss Prevention Data Sheets, and relevant local standards for correct system design. FM Approval of the foam extinguishing system is contingent upon the design, installation, testing and maintenance performed in accordance with NFPA 11 and/or FM Global Property Loss Prevention Data Sheet 4-12, Foam/Water Sprinkler Systems.

“SFFF compatible” refers to this product as being part of a SFFF Foam system that has been tested to recognized standards. Not all configurations are available. Please consult technical data and/or the Approval/Listing for usage requirements.



WARNING: Cancer and Reproductive Harm-
www.P65Warnings.ca.gov

3. TECHNICAL DATA

Physical Data

Appearance.....	Clear to yellowish liquid
Specific gravity at 68 °F (20 °C)	1,013 +/- 0.01 g/ml
Viscosity	Pseudoplastic*
pH.....	6,5 to 8,5
Freezing point	25 °F (-4 °C)
Recommended storage temperature	32 °F to 131 °F (0 to 55°C)
FM Approved storage temperature	35 °F to 120 °F (1.7 to 49 °C)
Suspended sediment (v/v)	Less than 0,2%

*see detailed viscosity data in section 16



4. ENVIRONMENTAL IMPACT

Viking ARK is formulated using specially selected raw materials for their fire performance and their environmental profile. The product contains no intentionally added fluorinated surfactants, polymers, and other organohalogens. Viking ARK is biodegradable and contains NO PFOS NOR PFOA. The handling of foam concentrate or foam solution spills should be in accordance with local regulations. Sewage systems should have no processing issues with foam solution based on Viking ARK concentrate but local sewage operators should be consulted in this respect. Viking ARK is formulated without the use of fluorinated surfactants. Full details can be found in the Safety Data Sheet (SDS).

5. APPLICATION

Viking ARK is intended for use on class B hydrocarbon fuel fires such as oil, Diesel and Gasoline as well as polar solvents such as IPA, Acetone, Ethanol, and Methanol. It is also suitable for class A fires such as wood, paper, textiles etc. Viking ARK is especially suited whenever a fluorine-free alternative with high fire performance is required. Viking ARK is tested for use in sprinkler systems. Refer to Listing or Approval for further details of approved use combinations.

Note: Not for use as a premixed solution.



TECHNICAL DATA

VIKING ARK SFFF FLUORINE FREE FOAM CONCENTRATE

The Viking Corporation, 210 N Industrial Park Drive, Hastings MI 49058
 Telephone: 269-945-9501 Technical Services: 877-384-5464 Fax: 269-818-1680 Email: techsvcs@vikingcorp.com
 Visit the Viking website for the latest edition of this technical data page.

TABLE 1: ORDERING INFORMATION

Volume	Packaging	Part Number	Approximate Shipping Weight**		Dimensions* In (mm)		Sales Region
			Lbs.	Kg	Inches	mm	
25 Litres	Can	V-SFFFARK/25	55**	25**	11x10x17	295x260x441	EMEA/APAC
200 Litres	Drum	V-SFFFARK/200	461**	209**	23x23x37	581x581x935	EMEA/APAC
1000 Litres	IBC Tote	V-SFFFARK/1000	2340	1060	47x39x45	1200x1000x1150	EMEA/APAC
6.5 US Gallons	Can	F24175-6.5	62**	28**	11x10x29	295x260x737	AMERICAS
55 US Gallons	Drum	F24175-55	488**	221**	23x23x37	581x581x935	AMERICAS
265 US Gallons	IBC Tote	F24175-265	2393	1084	47x39x45	1200x1000x1150	AMERICAS
Bulk	Bulk tanker deliveries available by special request. Contact Viking for availability.						

*Shipping Weight and Dimensions are approximate. **Weight does not include pallet.

6. PROPORTIONING

Viking ARK can be proportioned at the correct dilution using conventional equipment like bladder tanks and proportioners. Refer to the FM Approval for proportioning equipment approved for use with this concentrate.

7. FIRE PERFORMANCE & FOAMING

The fire performance of this product has been measured and documented according to "International Approvals" stated in this document. The foaming properties are depending on equipment used and other variables such as water and ambient temperatures.

8. SPRINKLER APPLICATION

Sprinkler applications are especially challenging for any foam due to the low operating pressure and the very low expansion reached. Applying foam through a sprinkler is a forceful application method and requires foam that can handle direct application and partial submersion into the fuel without losing its fire performance and burnback resistance. Foams that shall be regarded as suitable for sprinkler applications shall also be able to withstand limited time of water deluge directly onto the foam blanket and still maintain the burnback properties. Viking ARK has passed above described tests showing very good extinguishing and burnback properties. Refer to the FM Approval Guide for acceptable system configurations used with this concentrate and specific sprinkler SINS and their associated minimum application densities.

9. STORAGE / SHELF LIFE

Stored in original unbroken packaging the product will have a long shelf life. Shelf life in excess of 10 years will be found in temperate climates. As with all foams, shelf life will be dependent on storage temperatures and conditions.

10. SCOPE OF DELIVERY

We supply this product in 25 litre and 6.5 US gallon cans, 200 litre and 55 US gallon drums, 1000 litre and 265 US gallon IBC containers and in bulk on special request.

11. INSPECTIONS, TESTS AND MAINTENANCE

The foam concentrate should be tested annually. Refer to respective requirements, according to the relevant standards for Inspection, Testing and Maintenance. If applicable, refer to FM Global Property Loss Prevention Datasheet 4-12 for specific test and commissioning criteria. In addition, the "Authority Having Jurisdiction" (AHJ) may have additional maintenance, testing and inspection requirements that must be followed.



TECHNICAL DATA

VIKING ARK SFFF FLUORINE FREE FOAM CONCENTRATE

The Viking Corporation, 210 N Industrial Park Drive, Hastings MI 49058

Telephone: 269-945-9501 Technical Services: 877-384-5464 Fax: 269-818-1680 Email: techsvcs@vikingcorp.com

Visit the Viking website for the latest edition of this technical data page.

12. DISPOSAL



At the end of use the product packaging should be disposed of via the national recycling system. Some IBC Tote containers may be part of a national collection scheme. Details will be attached to the IBC Tote if this service is available. Foam Concentrate should be disposed of according to local regulations.

13. AVAILABILITY

The product is available directly from Viking and official distributors only.

Americas:

The Viking Corporation
5150 Beltway SE
Caledonia, MI 49316
Tel.: (800) 968-9501
Fax: 269-818-1680
Technical Services: 1-877-384-5464
techsvcs@vikingcorp.com

EU:

Viking S.A.
21, Z.I. Haneboesch
L-4562 Differdange / Nieder Korn
Tel.: +352 58 37 37 - 1
Fax: +352 58 37 36
vikinglux@viking-emea.com

Asia Pacific (APAC) Main Office:

The Viking Corporation (Far East) Pte. Ltd.
69 Tuas View Square
Westlink Techpark, Singapore 637621
Tel: (+65) 6 278 4061
Fax: (+65) 6 278 4609
vikingAPAC@vikingcorp.com

14. GUARANTEE

For details of warranty, refer to Viking's current list price schedule or contact Viking directly.

15. COMPATIBILITY

Contact Viking with questions regarding the compatibility of this product.

16. VISCOSITY

The viscosity flow curves are determined by Brookfield RST rheometer from low to high shear rates. The viscosity curves below are determined by calculating the average value of at least 8 different measurements and add a safety margin of three standard deviations to the average. The viscosity curves are determined for 68 °F and 41 °F (20 °C and 5 °C). In the table below the kinematic viscosity (mm²/s) is calculated as dynamic viscosity (mPa·s) divided by the specific gravity of the concentrate.

Shear Rate (s ⁻¹)	Dynamic Viscosity (mPa/s)		Kinetic Viscosity (mm ² /s)	
	68 °F (20 °C)	41 °F (5 °C)	68 °F (20 °C)	41 °F (5 °C)
10,7	3083	3258	3043	3217
21,5	1726	1851	1703	1827
53,7	791	870	781	859
107,4	444	505	438	499
214,8	261	304	258	300
375,0	174	206	171	204
537,0	136	164	134	162
1074,0	106	121	104	119
1611,0	68	88	67	87
2148,0	58	75	57	74
2792,2	79	87	78	86



TECHNICAL DATA

**VIKING ARK SFFF
FLUORINE FREE
FOAM CONCENTRATE**

The Viking Corporation, 210 N Industrial Park Drive, Hastings MI 49058
Telephone: 269-945-9501 Technical Services: 877-384-5464 Fax: 269-818-1680 Email: techsvcs@vikingcorp.com
Visit the Viking website for the latest edition of this technical data page.

Viscosity vs Shear Rate - Viking ARK SFFF @ 68 °F (20 °C)

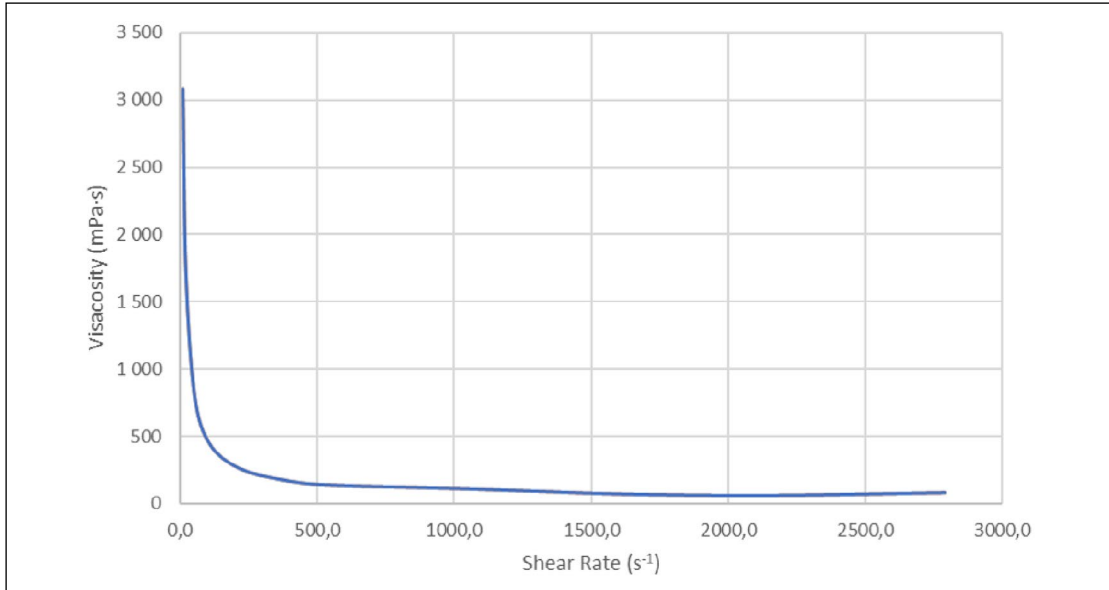

Viscosity vs Shear Rate - Viking ARK SFFF @ 41 °F (5 °C)

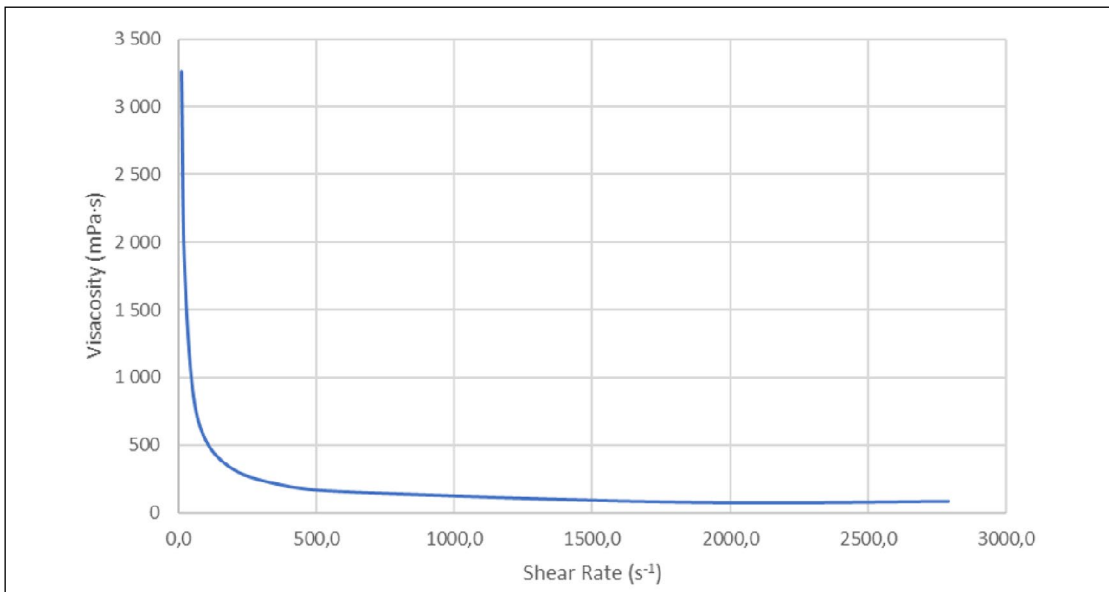



TECHNICAL DATA

MODEL J-1 ALARM CHECK VALVE VERTICAL TRIM

Order Alarm Valve separately.

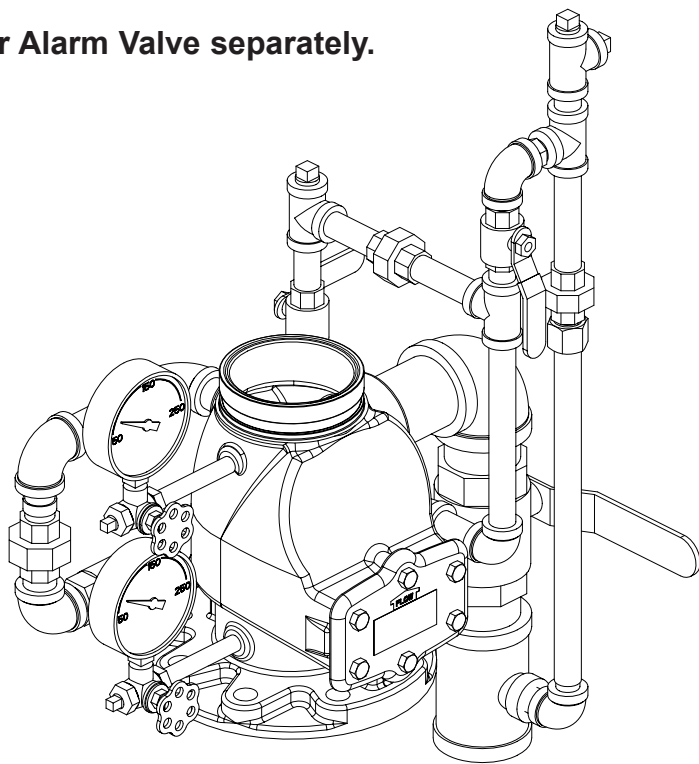

This Trim Chart is for use with the following Viking Trim Sets

Valve Size	Galvanized	Brass
3" (DN80)	08633	11428
4" (DN100)	08634	11429
6" (DN150)	08635	11430
8" (DN200)	08636	11431



WARNING: Cancer and Reproductive Harm-
www.P65Warnings.ca.gov

NOTES: For use with Trim Chart on page 27 b.

General Notes:

- Valve must be trimmed as shown. Any deviation from trim size or arrangement may affect the proper operation of the valve.
- All pipe, 3/4" (20 mm) and smaller, shall be galvanized steel except when other materials are specified in the technical data for the system used. All trim components must be listed for up to 300 PSI (20.7 bar) Water Working Pressure.
- Dimensions in parentheses are millimeter.
- Viking uses ASME fitting designations. Tee's shall be called out in the following order: 1 - largest outlet on run; 2 - Smaller outlet on run; 3 - Branch size.

NOTE: Viking uses ASME fitting designations. Tee's shall be called out in the following manner: 1-Largest outlet on run; 2-Smaller outlet on run; 3-Branch size.

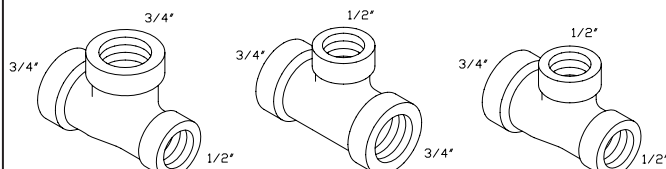

Note 1: When using a water motor alarm, a strainer is required. Circuit closer vent trim may be required when an alarm pressure switch is used. (See technical data for the retard chamber.)

Note 2: This location may be used for optional pressure relief valve (not available from Viking). Install 3/4" (20 mm) tee and listed pressure relief valve.

Note 3: To supply an optional excess pressure pump (not available from Viking and not a listed assembly), replace 1/2" ell marked "A" with a tee. Replace 3/4" ell marked "B" with a tee to connect outlet from excess pressure pump. Do not exceed listed water working pressure rating of system components. Perform hydrostatic tests in accordance with recognized Installation Standards.

Note 4: Location for non-interruptible pressure switch. When waterflow through the alarm valve occurs, supply to this location cannot be shut off until water flow through the alarm valve stops. **Caution** - Non-interruptible alarm port may only be used on systems with constant pressure. A retard chamber may not be installed on the non-interruptible alarm port.

Note 5: Component specified is included in Viking trim sets; do not substitute. Use of components other than specified will void any listings and approvals and may affect operation of the valve.

Note 6: 300 PSI (20.7 bar) water pressure gauges are provided with trim. 600 PSI (41.4 bar) water pressure gauges are available. Order separately when needed*. Refer to current Viking Price Book.

* NFPA 13 requires gauges to have a minimum limit not less than twice the normal water working pressure at the point where the gauges are installed. When normal water working pressure exceeds 150 PSI (10.3 bar), order 600 PSI (41.4 bar) water pressure gauges separately.



TECHNICAL DATA

MODEL J-1 ALARM CHECK VALVE VERTICAL TRIM

Available since 1997

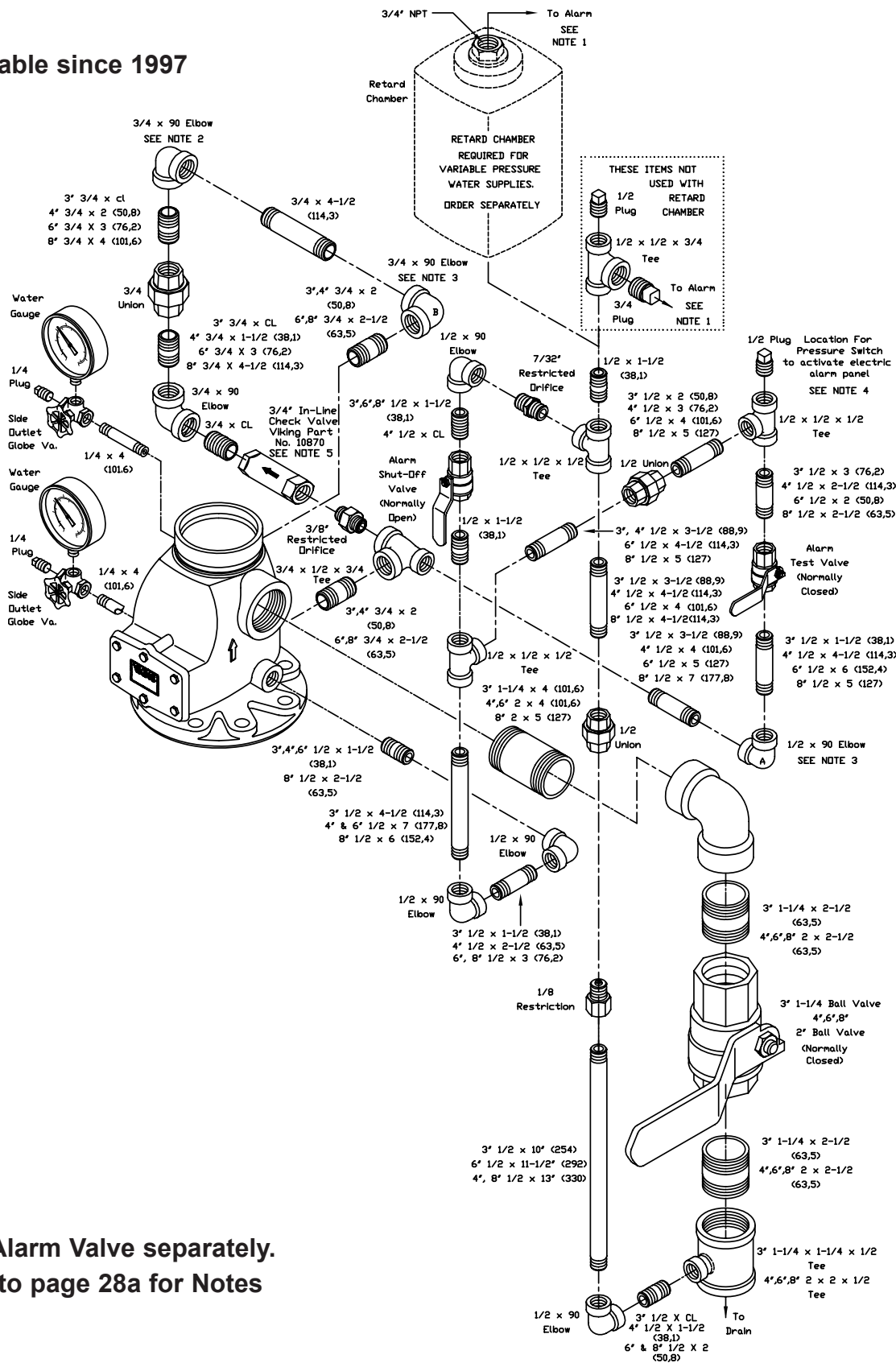

Order Alarm Valve separately.
Refer to page 28a for Notes



TECHNICAL DATA

MODEL J-1 ALARM CHECK VALVE VERTICAL TRIM

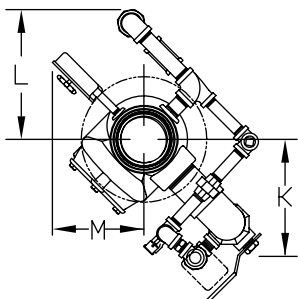

Model J-1 Alarm Check Valve Vertical Trim, and Pressure Switches Must be Ordered Separately Refer to Technical Data.

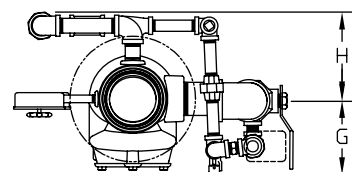

All dimensions are approximations. Dimensions in parentheses are millimeter.

SIZE	A	B	C	D	E	F	G	H	K	L	M	R
3" (DN80)	10-1/8 (257)	7-1/4 (184)	7-3/4 (197)	7-3/4 (197)	10-1/8 (257)	11-3/4 (298)	5 (127)	6-1/2 (165)	7-1/4 (184)	10 (254)	5-1/2 (140)	11 (279)
4" (DN100)	10-5/8 (270)	7-1/2 (191)	9 (229)	9 (229)	12-1/4 (311)	12-3/8 (314)	5-1/2 (140)	6-1/4 (159)	8-3/4 (222)	10 (254)	6-1/2 (165)	12-1/2 (318)
6" (DN150)	13-3/8 (340)	10-1/4 (260)	9-3/4 (248)	9-3/4 (248)	13 (330)	11-1/4 (286)	6 (153)	8-3/4 (222)	9-1/4 (235)	11 (279)	7 (178)	12-1/2 (318)
8" (DN200)	17 (432)	8-1/4 (210)	11 (279)	10-1/2 (267)	14-1/4 (362)	6-3/4 (171)	6-1/2 (165)	10 (254)	10-7/8 (276)	12 (305)	7-1/2 (191)	12-1/2 (318)

MODEL J-1 ALARM CHECK VALVE WITH VERTICAL TRIM FOR CONSTANT PRESSURE WATER SUPPLY

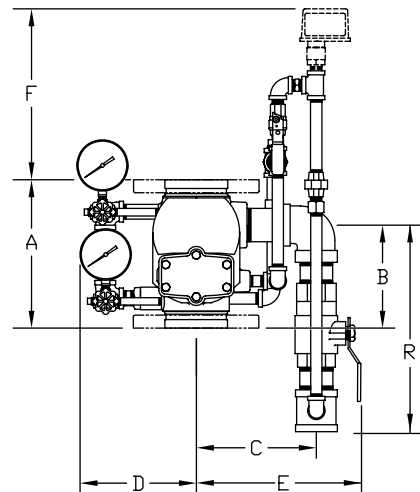

All dimensions are approximations. Dimensions in parentheses are millimeter.

SIZE	A	B	C	D	E	F	G	H	J	K	L	M	N	O	P	R
3" (DN80)	10-1/8 (257)	7-1/4 (184)	7-3/4 (197)	7-3/4 (197)	10-1/8 (257)	20 (508)	6-1/4 (159)	6-1/2 (165)	11-3/4 (299)	7-1/4 (184)	10 (254)	5-1/2 (140)	5-7/8 (149)	28-1/8 (714)	4-3/4 (121)	11 (279)
4" (DN100)	10-5/8 (270)	7-1/2 (191)	9 (229)	9 (229)	12-1/4 (311)	20-1/2 (521)	6-1/2 (165)	6-1/4 (159)	13-3/8 (340)	8-3/4 (222)	10 (254)	6-1/2 (165)	5-7/8 (149)	28-5/8 (733)	5-1/4 (134)	12-1/2 (318)
6" (DN150)	13-3/8 (340)	10-1/4 (260)	9-3/4 (248)	9-3/4 (248)	13 (330)	19-1/4 (489)	6-3/4 (171)	8-3/4 (222)	14-1/8 (359)	9-1/4 (235)	11 (279)	7 (178)	5-7/8 (149)	28 (711)	7 (178)	12-1/2 (318)
8" (DN200)	17 (432)	8-1/4 (210)	11 (279)	10-1/2 (267)	14-1/4 (362)	13-1/2 (343)	7-1/2 (191)	10 (254)	16-1/4 (413)	10-7/8 (276)	12 (305)	7-1/2 (191)	5-7/8 (149)	23-5/8 (600)	9 (229)	12-1/2 (318)

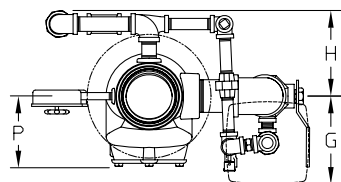
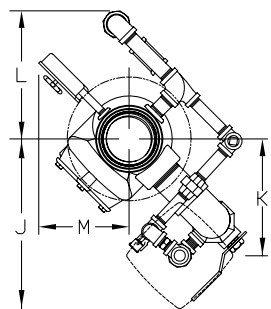

Model J-1 Alarm Check Valve Vertical Trim, Retard Chamber, Pressure Switches, and Circuit Closer Vent Trim Must be Ordered Separately Refer to Technical Data.

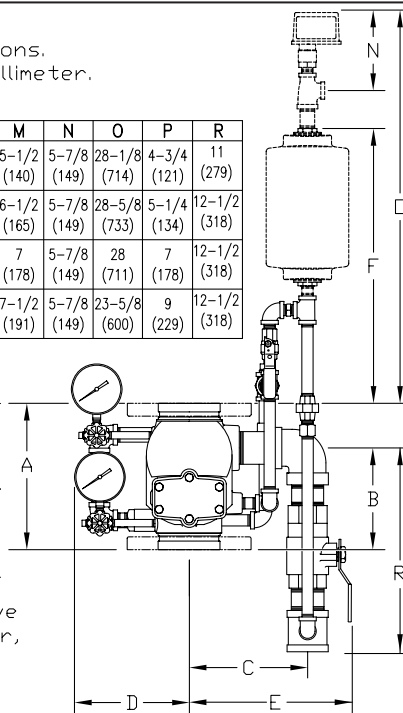

J-1 ALARM CHECK VALVE WITH VERTICAL TRIM, RETARD CHAMBER, AND PRESSURE SWITCH FOR VARIABLE PRESSURE WATER SUPPLY



TECHNICAL DATA

APPROVED SPRINKLERS FOR USE WITH FOAM CONCENTRATES

The Viking Corporation, 210 N Industrial Park Drive, Hastings MI 49058

Telephone: 269-945-9501 Technical Services: 877-384-5464 Fax: 269-818-1680 Email: techsvcs@vikingcorp.com

Visit the Viking website for the latest edition of this technical data page www.vikinggroupinc.com

1. DESCRIPTION

Viking Pendent and Upright Foam-Water Sprinklers are non-aspirated foam discharge devices. Viking Pendent and Upright Foam-Water Sprinklers are FM Approved and UL Listed in both closed sprinkler (with bulb or fusible element) and open sprinkler (bulb removed) configurations.

Features:

- Tested and Approved as foam-water sprinklers with specific foam concentrates (see Performance Data).
- K-factors available: K5.6 (K80.6), K8.0 (K115.2), and K11.2 (K161.3)

2. LISTINGS AND APPROVALS

Viking Foam Water Sprinklers are FM Approved and/or UL Listed as part of a fire extinguishing system combining designated foam concentrates, bladder tanks and proportioning devices. Approved and Listed system components can be found at www.approvalguide.com and <https://iq.ulprospector.com>.



FM Approved – Low Expansion Foam Systems (FM5130)



UL Listed – GFGV.EX27255 (UL162)

“SFFF compatible” refers to this product as being part of a SFFF Foam system that has been tested to recognized standards. Not all configurations are available. Please consult technical data and/or the Approval/Listing for usage requirements.

Refer to the FM Approval and UL Listings tables in this document for technical performance data.

3. TECHNICAL DATA

Refer to the applicable sprinkler’s data page for product data.

4. SCOPE OF DELIVERY

Ensure that all components are complete and in good condition. Viking Foam/Water Sprinklers are supplied boxed with protective shield or cap.

5. AVAILABILITY

Please contact Viking for further information.

Americas:

The Viking Corporation
5150 Beltway SE
Caledonia, MI 49316
Tel.: (800) 968-9501
Fax: 269-818-1680
Technical Services: 1-877-384-5464
techsvcs@vikingcorp.com

6. PRODUCT VARIANTS

Please refer to relevant sprinkler data page.

7. SCOPE OF DELIVERY

Ensure that all components are complete and in good condition. Viking Foam/Water Sprinklers are supplied boxed with protective shield or cap.

8. INSTALLATION

Refer to appropriate Installation Standards (i.e. NFPA, VdS, LPCB, etc.) and / or applicable FM Global Property Loss Prevention Data Sheets such as 4-12, Foam Extinguishing Systems.



WARNING: Cancer and Reproductive Harm-
www.P65Warnings.ca.gov





TECHNICAL DATA

**APPROVED SPRINKLERS
FOR USE WITH FOAM
CONCENTRATES**

The Viking Corporation, 210 N Industrial Park Drive, Hastings MI 49058

Telephone: 269-945-9501 Technical Services: 877-384-5464 Fax: 269-818-1680 Email: techsvcs@vikingcorp.com

Visit the Viking website for the latest edition of this technical data page www.vikinggroupinc.com

9. OPERATION

During fire conditions, the heat-sensitive liquid in the glass bulb expands, causing the glass to shatter, releasing the pip cap and sealing spring assembly. Water or Foam/Water Solution flowing through the sprinkler orifice strikes the sprinkler deflector, forming a uniform spray pattern to extinguish or control the fire.

10. GUARANTEE

For details of warranty, refer to Viking's current list price schedule or contact Viking directly.

11. INSPECTION, TESTS AND MAINTENANCE

Refer to respective requirements, according to the relevant standards for Inspection, Testing and Maintenance. Refer to NFPA 25 for Inspection, Testing and Maintenance requirements.

If applicable, refer to FM Global Property Loss Prevention Datasheet 4-12 for specific test and commissioning criteria. In addition, the "Authority Having Jurisdiction" (AHJ) may have additional maintenance, testing and inspection requirements that must be followed.

WARNING

Any system maintenance or testing that involves placing a control valve or detection system out of service may eliminate the fire protection capabilities of that system. Prior to proceeding, notify all Authorities Having Jurisdiction. Consideration should be given to employment of a fire patrol in the affected areas.

12. DISPOSAL



At end of use the product described here should be disposed of via the national recycling system.

13. ACCESSORIES AND SPARE PARTS

Please refer to relevant sprinkler data page.



TECHNICAL DATA

APPROVED SPRINKLERS FOR USE WITH FOAM CONCENTRATES

The Viking Corporation, 210 N Industrial Park Drive, Hastings MI 49058
 Telephone: 269-945-9501 Technical Services: 877-384-5464 Fax: 269-818-1680 Email: techsvcs@vikingcorp.com
 Visit the Viking website for the latest edition of this technical data page www.vikinggroupinc.com

TABLE 1

FM APPROVALS: HYDROCARBONS ¹														
VIKING Foam Concentrate	Nominal K-factor		Sprinkler Identification Number (SIN)		Height				Listed ² Foam Design Density		Water Discharge Density		Tested ³ Sprinkler Pressure	
					Minimum		Maximum							
	U.S.	Metric ⁴	Upright	Pendent	Ft.	m	Ft.	m	gpm/ft ²	Lpm/m ²	gpm/ft ²	Lpm/m ²	PSI	bar
ARK 3%	5.6	80.6	VK1001 VK3001	--	6	1.8	24.8	7.6	0.3	12.2	0.3	12.2	29	1.99
	5.6	80.6	--	VK1021 VK3021	6	1.8	20	6.1	0.3	12.2	0.3	12.2	29	1.99
	8.0	115.2	VK200 VK204 VK350 VK351	--	9	2.7	45	13.7	0.4	16.3	0.4	16.3	25	1.72
	8.0	115.2	--	VK2021 VK2022 VK3521 VK3522	8.5	2.6	44	13.4	0.3	12.2	0.3	12.2	14	0.97
	11.2	161.3	VK530 VK531	--	9	2.7	45	14	0.4	16.3	0.4	16.3	13	0.89
	11.2	161.3	--	VK377 VK536	6	1.8	25.2	8	0.4	16.3	0.4	16.3	13	0.89
USP 3%	5.6	80.6	VK1001 VK3001	--	6	1.8	24.8	7.6	0.2	8.1	0.3	12.2	13	0.89
	5.6	80.6	--	VK1021 VK3021	6	1.8	44	13.4	0.2	8.1	0.3	12.2	13	0.89
	8.0	115.2	VK200 VK204 VK350 VK351	--	9	2.7	45	13.7	0.3	12.2	0.3	12.2	14	0.96
	8.0	115.2	--	VK2021 VK3521 VK3522 VK2022	8	2.4	44	13.4	0.3	12.2	0.3	12.2	14	0.96
	11.2	161.3	--	VK377 VK536	6	1.8	25.2	8	0.3	12.2	0.3	12.2	7	0.48

1. This table shows approvals available at the time of printing.
 2. Density indicated is minimum application density required per FM5130 Standard for Foam Extinguishing Systems. This density cannot be reduced.
 3. The pressure indicated is the minimum starting pressure required for the sprinkler. However, the minimum density shown overrides the minimum starting pressure (depending on head spacing) and cannot be reduced.
 4. Metric K-factor shown is for use when pressure is measured in bar. When pressure is measured in kPa, divide the metric K-factor shown by 10.0.



TECHNICAL DATA

APPROVED SPRINKLERS FOR USE WITH FOAM CONCENTRATES

The Viking Corporation, 210 N Industrial Park Drive, Hastings MI 49058
 Telephone: 269-945-9501 Technical Services: 877-384-5464 Fax: 269-818-1680 Email: techsvcs@vikingcorp.com
 Visit the Viking website for the latest edition of this technical data page www.vikinggroupinc.com

TABLE 2

FM APPROVALS: JET A1¹

VIKING Foam Concentrate	Nominal K-factor		Sprinkler Identification Number (SIN)		Height				Listed ² Foam Design Density		Water Discharge Density		Tested ³ Sprinkler Pressure	
					Minimum		Maximum							
	U.S.	Metric ⁴	Upright	Pendent	Ft.	m	Ft.	m	gpm/ft ²	Lpm/m ²	gpm/ft ²	Lpm/m ²	PSI	bar
USP 3%	5.6	80.6	--	VK1021, VK3021	8.5	2.6	44	13.4	0.2	8.1	0.3	12.2	13	0.89

- This table shows approvals available at the time of printing.
- Density indicated is minimum application density required per FM5130 Standard for Foam Extinguishing Systems. This density cannot be reduced.
- The pressure indicated is the minimum starting pressure required for the sprinkler. However, the minimum density shown overrides the minimum starting pressure (depending on head spacing) and cannot be reduced.
- Metric K-factor shown is for use when pressure is measured in bar. When pressure is measured in kPa, divide the metric K-factor shown by 10.0.

TABLE 3

FM APPROVALS: ALCOHOL - IPA¹

VIKING Foam Concentrate	Nominal K-factor		Sprinkler Identification Number (SIN)		Height				Listed ² Foam Design Density		Tested ³ Sprinkler Pressure	
					Minimum		Maximum					
	U.S.	Metric ⁴	Upright	Pendent	Ft.	m	Ft.	m	gpm/ft ²	Lpm/m ²	PSI	bar
ARK 3%	5.6	80.6	VK1001 VK3001	--	6	1.8	24.8	7.6	0.3	12.2	29	1.99
	5.6	80.6	--	VK1021 VK3021	6	1.8	24	7.3	0.3	12.2	29	1.99
	8.0	115.2	VK200 VK204 VK350 VK351	--	6.5	2	45	13.7	0.4	16.3	25	1.7
	8.0	115.2	--	VK2021 VK2022 VK3521 VK3522	6	1.8	44	13.4	0.3	12.2	14	0.97
	11.2	161.3	--	VK377 VK536	6	1.8	44	13.4	0.4	16.3	13	0.89
	11.2	161.3	VK530 VK531	--	6	1.8	45	13.7	0.4	16.3	13	0.89

- This table shows approvals available at the time of printing.
- Density indicated is minimum application density required per FM5130 Standard for Foam Extinguishing Systems. This density cannot be reduced.
- The pressure indicated is the minimum starting pressure required for the sprinkler. However, the minimum density shown overrides the minimum starting pressure (depending on head spacing) and cannot be reduced.
- Metric K-factor shown is for use when pressure is measured in bar. When pressure is measured in kPa, divide the metric K-factor shown by 10.0.



TECHNICAL DATA

APPROVED SPRINKLERS FOR USE WITH FOAM CONCENTRATES

The Viking Corporation, 210 N Industrial Park Drive, Hastings MI 49058
 Telephone: 269-945-9501 Technical Services: 877-384-5464 Fax: 269-818-1680 Email: techsvcs@vikingcorp.com
 Visit the Viking website for the latest edition of this technical data page www.vikinggroupinc.com

TABLE 4

FM APPROVALS: KETONE - ACETONE¹

VIKING Foam Concentrate	Nominal K-factor		Sprinkler Identification Number (SIN)		Height				Listed ² Foam Design Density		Tested ³ Sprinkler Pressure	
					Minimum		Maximum					
	U.S.	Metric ⁴	Upright	Pendent	Ft.	m	Ft.	m	gpm/ft ²	Lpm/m ²	PSI	bar
ARK 3%	5.6	80.6	VK1001 VK3001	--	6	1.8	24.8	7.6	0.3	12.2	29	1.99
	5.6	80.6	--	VK1021 VK3021	6	1.8	24	7.3	0.3	12.2	29	1.99
	8.0	115.2	VK200 VK204 VK350 VK351	--	6.5	2	45	13.7	0.3	12.2	14	0.97
	8.0	115.2	--	VK2021 VK2022 VK3521 VK3522	6	1.8	44	13.4	0.3	12.2	14	0.97
	11.2	161.3	VK530 VK531	--	6	1.8	45	13.7	0.3	12.2	7	0.48
	11.2	161.3	--	VK377 VK536	6	1.8	25.2	8	0.3	12.2	7	0.48

- This table shows approvals available at the time of printing.
- Density indicated is minimum application density required per FM5130 Standard for Foam Extinguishing Systems. This density cannot be reduced.
- The pressure indicated is the minimum starting pressure required for the sprinkler. However, the minimum density shown overrides the minimum starting pressure (depending on head spacing) and cannot be reduced.
- Metric K-factor shown is for use when pressure is measured in bar. When pressure is measured in kPa, divide the metric K-factor shown by 10.0.

TABLE 5

FM APPROVALS: ETHANOL¹

VIKING Foam Concentrate	Nominal K-factor		Sprinkler Identification Number (SIN)		Height				Listed ² Foam Design Density		Tested ³ Sprinkler Pressure	
					Minimum		Maximum					
	U.S.	Metric ⁴	Upright	Pendent	Ft.	m	Ft.	m	gpm/ft ²	Lpm/m ²	PSI	bar
ARK 3%	8.0	115.2	VK200 VK204 VK350 VK351	--	6.5	2	45	13.7	0.3	12.2	14	0.97
	8.0	115.2	--	VK2021 VK2022 VK3521 VK3522	6.0	1.8	44.8	13.7	0.30	12.2	14	0.97
	11.2	161.3	VK530 VK531	--	7.7	2.3	20.6	6.3	0.30	12.2	7	0.48
	11.2	161.3	--	VK377 VK536	6.0	1.8	44.8	13.7	0.30	12.2	7	0.48

- This table shows approvals available at the time of printing.
- Density indicated is minimum application density required per FM5130 Standard for Foam Extinguishing Systems. This density cannot be reduced.
- The pressure indicated is the minimum starting pressure required for the sprinkler. However, the minimum density shown overrides the minimum starting pressure (depending on head spacing) and cannot be reduced.
- Metric K-factor shown is for use when pressure is measured in bar. When pressure is measured in kPa, divide the metric K-factor shown by 10.0.



TECHNICAL DATA

APPROVED SPRINKLERS FOR USE WITH FOAM CONCENTRATES

The Viking Corporation, 210 N Industrial Park Drive, Hastings MI 49058
 Telephone: 269-945-9501 Technical Services: 877-384-5464 Fax: 269-818-1680 Email: techsvcs@vikingcorp.com
 Visit the Viking website for the latest edition of this technical data page www.vikinggroupinc.com

TABLE 6

UL LISTINGS: HYDROCARBON FUELS¹

VIKING Foam Concentrate	Nominal K-factor		Sprinkler Identification Number (SIN)		Listed ² Foam Design Density		Tested ³ Sprinkler Pressure	
	U.S.	Metric ⁴	Upright	Pendent	gpm/ft ²	Lpm/m ²	PSI	bar
USP ⁵ 3%	5.6		--	VK3021	0.22	9.0	7	0.48
	8.0	115.2	--	VK2021 VK2022 VK3521 VK3522	0.22	9.0	7	0.48
	11.2	161.3	VK530 VK531 VK533	VK377 VK536	0.32	13	7	0.48

1. This table shows approvals available at the time of printing.
2. Density indicated is minimum application density required per FM5130 Standard for Foam Extinguishing Systems. This density cannot be reduced.
3. The pressure indicated is the minimum starting pressure required for the sprinkler. However, the minimum density shown overrides the minimum starting pressure (depending on head spacing) and cannot be reduced.
4. Metric K-factor shown is for use when pressure is measured in bar. When pressure is measured in kPa, divide the metric K-factor shown by 10.0.
5. For fresh water use only.

Features

- One or two switch models available
- Independent switch adjustment on two switch models, no tools needed
- Two 1/2" conduit/cable entrances
- Separate isolated wiring chambers
- Non-corrosive pressure connection
- VdS version available
- Non-Conductive enclosure



NOTICE

This document contains important information on the installation and operation of PS10 pressure switches. Please read all instructions carefully before beginning installation. A copy of this document is required by NFPA 72 to be maintained on site.



Installation

The Potter PS10 Series Pressure Actuated Switches are designed for the detection of a waterflow condition in automatic fire sprinkler systems of particular designs such as wet pipe systems with alarm check valves, dry pipe, preaction, or deluge valves. The PS10 is also suitable to provide a low pressure supervisory signal; adjustable between 4 and 15 psi (0,27 and 1,03 bar).

1. Apply Teflon tape to the threaded male connection on the device. (Do not use pipe dope)
2. Device should be mounted in the upright position (threaded connection down).
3. Tighten the device using a wrench on the flats on the device.

Wiring Instructions

1. Remove the tamper resistant screw with the special key provided.
2. Carefully place a screwdriver on the edge of the knockout and sharply apply a force sufficient to dislodge the knockout plug. See Fig 9.
3. Run wires through an approved conduit connector and affix the connector to the device. NEMA 4 rated conduit and fittings are required for outdoor use.
4. Connect the wires to the appropriate terminal connections for the service intended. See Figures 2,4,5, and 6. See Fig. 7 for two switch, one conduit wiring.

Technical Specifications

Conduit Entrances	Two knockouts for 1/2" conduit provided. Individual switch compartments and ground screw suitable for dissimilar voltages
Contact Ratings	SPDT (Form C) 10.1 Amps at 125/250VAC, 2.0 Amps at 30VDC One SPDT in PS10-1, Two SPDT in PS10-2
Cover Tamper	Cover incorporates tamper resistant fastener that requires a special key for removal. One key is supplied with each device.
Differential	2 psi (0,13 bar) typical
Dimensions	3.78"(9,6cm)Wx3.20"(8,1cm)Dx4.22"(10,7cm)H
Enclosure	Cover: Weather/UV/Flame Resistant High Impact Composite Base: Die Cast All parts have corrosion resistant finishes
Environmental Limitations	-40° F to 140° F (-40°C to 60°C) NEMA 4/IP66 Rated Enclosure indoor or outdoor when used with NEMA 4 conduit fittings
Factory Adjustment	4 - 8 psi (0,27 - 0,55 bar)
Maximum System Pressure	300 psi (20,68 bar)
Pressure Connection	Nylon 1/2" NPT male
Pressure Range	4-15 psi (0,27 - 1,03 bar)
Service Use	NFPA 13, 13D, 13R, 72

*Specifications subject to change without notice.

Testing and Adjustment

NOTE: Testing the PS10 may activate other system connected devices. The operation of the pressure alarm switch should be tested upon completion of installation and periodically thereafter in accordance with the applicable NFPA codes and standards and/or the authority having jurisdiction (manufacturer recommends quarterly or more frequently). There should be no need to adjust the PS10 when it is used as a pressure type waterflow indicator. It is factory set to comply with UL and FM standards.

Wet System

Method 1: When using PS10 and control unit with retard - connect PS10 into alarm port piping on the input side of retard chamber and electrically connect PS10 to control unit that provides a retard to compensate for surges. Insure that no unsupervised shut-off valves are present between the alarm check valve and PS10.

Method 2: When using the PS10 for local bell application or with a control that does not provide a retard feature - the PS10 must be installed on the alarm outlet side of the retard chamber of the sprinkler system.

Testing: Accomplished by opening the inspector's end-of-line test valve. Allow time to compensate for system or control retard.

NOTE: Method 2 is not applicable for remote station service use, if there is an unsupervised shut-off valve between the alarm check valve and the PS10.

Wet System With Excess Pressure

Connect PS10 into alarm port piping extending from alarm check valve. Retard provisions are not required. Insure that no unsupervised shut-off valves are present between the alarm check valve and the PS10.

Testing: Accomplished by opening the water by-pass test valve or the inspector's end-of-line test valve. When using end-of-line test, allow time for excess pressure to bleed off.

Dry System

Connect PS10 into alarm port piping that extends from the intermediate chamber of the alarm check valve. Install on the outlet side of the in-line check valve of the alarm port piping. Insure that no unsupervised shut-off valves are present between the alarm check valve and the PS10.

Testing: Accomplished by opening the water by-pass test valve.

NOTE: The above tests may also activate any other circuit closer or water motor gongs that are present on the system.

Dimensions

Fig 1

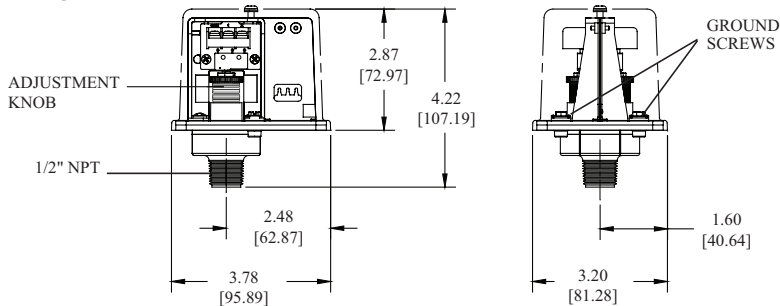

NOTE: To prevent leakage, apply Teflon tape sealant to male threads only.

DWG# 930-1

Switch Clamping Plate Terminal

Fig 2

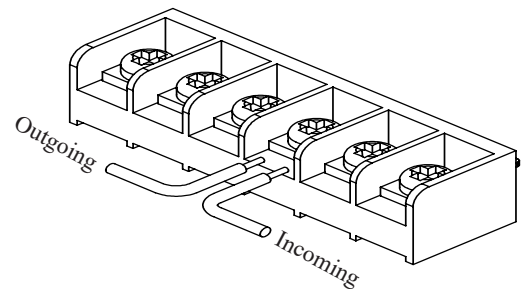

WARNING

An uninsulated section of a single conductor should not be looped around the terminal and serve as two separate connections. The wire must be severed, thereby providing supervision of the connection in the event that the wire becomes dislodged from under the terminal.

Typical Sprinkler Applications

Fig 3

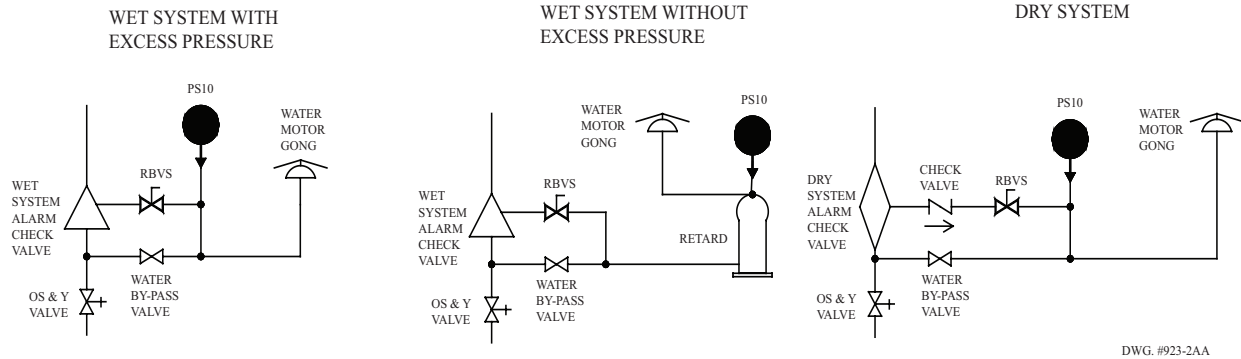

CAUTION

Closing of any shutoff valves between the alarm check valve and the PS10 will render the PS10 inoperative. To comply with NFPA-72 any such valve shall be electrically supervised with a supervisory switch such as Potter Model RBVS.

Low Pressure Signal Connection
Fig 4

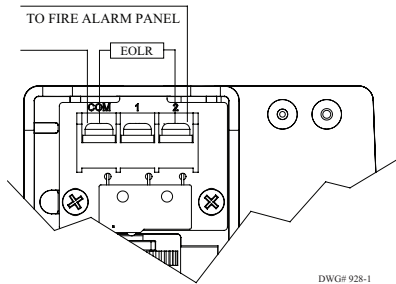

Waterflow Signal Connection
Fig 5

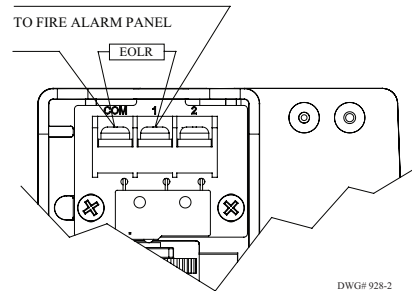

Local Bell For Waterflow Connection
Fig 6

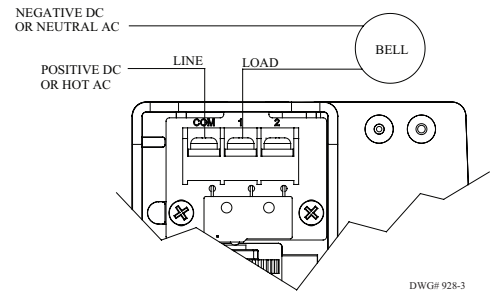

One Conduit Wiring
Fig 7

Break out thin section of divider to provide path for wires when wiring both switches from one conduit entrance.

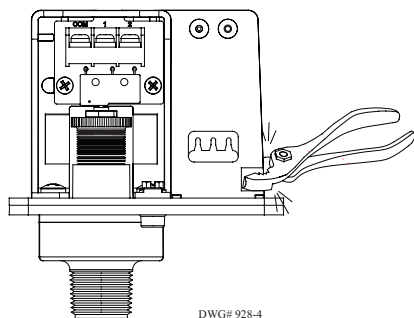

Switch Operation
Fig 8

Terminal
C: Common
1: Closed when installed under normal system pressure.
2: Open when installed under normal system pressure. Closes on pressure drop. Use for low pressure supervision.

W/ PRESSURE APPLIED

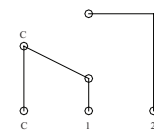

Terminal
1: Open with no pressure supplied. Closes upon detection of pressure. Use for waterflow indication.
2: Closed with no pressure applied.

W/O PRESSURE APPLIED

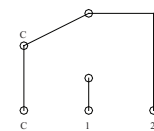

Removing Knockouts

Fig 9

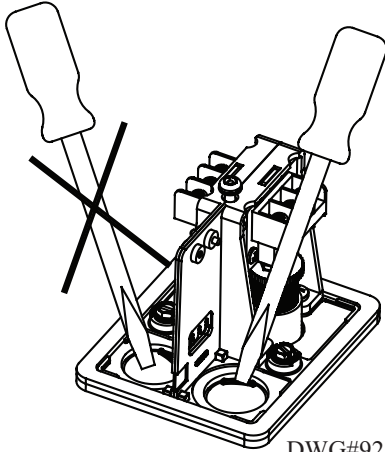

DWG#928-5

**Engineer/Architect Specifications
Pressure Type Waterflow Switch**

Pressure type waterflow switches; shall be a Model PS10 as manufactured by Potter Electric Signal Company, St Louis MO., and shall be installed on the fire sprinkler system as shown and or specified herein.

Switches shall be provided with a 1/2" NPT male pressure connection and shall be connected to the alarm port outlet of; Wet Pipe Alarm Valves, Dry Pipe Valves, Pre-Action Valves, or Deluge Valves. The pressure switch shall be actuated when the alarm line pressure reaches 4 - 8 psi (0,27 - 0,55 bar).

Pressure type waterflow switches shall have a maximum service pressure rating of 300 psi (20,68 bar) and shall be factory adjusted to operate on a pressure increase of 4 - 8 psi (0,27 - 0,55 bar)

Pressure switch shall have one or two form C contacts, switch contact rating 10.1 Amps at 125/250 VAC, 2.0 Amps at 30 VDC.

Pressure type waterflow switches shall have two conduit entrances one for each individual switch compartment to facilitate the use of dissimilar voltages for each individual switch.

The cover of the pressure type waterflow switch shall be Weather/UV/Flame Resistant High Impact Composite with rain lip and shall attach with one tamper resistant screw. The Pressure type waterflow switch shall be suitable for indoor or outdoor service with a NEMA 4/IP66 rating.

The pressure type waterflow switch shall be UL ULc and CSFM listed, FM and LPC approved and NYMEA accepted.

WARNING

- Installation must be performed by qualified personnel and in accordance with all national and local codes and ordinances.
- Shock hazard. Disconnect power source before servicing. Serious injury or death could result.
- Read all instructions carefully and understand them before starting installation. Save instructions for future use. Failure to read and understand instructions could result in improper operation of device resulting in serious injury or death.
- Risk of explosion. Not for use is hazardous locations. Serious injury or death could result.

CAUTION

- Do not tighten by grasping the switch enclosure. Use wrenching flats on the bushing only. Failure to install properly could damage the switch and cause improper operation resulting in damage to equipment and property.
- To seal threads, apply Teflon tape to male threads only. Using joint compounds or cement can obstruct the pressure port inlet and result in improper device operation and damage to equipment.
- Do not over tighten the device, standard piping practices apply.

Ordering Information

Model	Description	Part Number
PS10-1	Pressure switch with one set SPDT contacts	1340103
PS10-2	Pressure switch with two sets SPDT contacts	1340104
Hex Key		5250062
Cover Tamper Switch Kit		0090200

Tamper

Cover incorporates tamper resistant fastener that requires a special key for removal. One key is supplied with each device. For optional cover tamper switch kit, order Stock No. 0090200. See bulletin #5401200 PSCTSK.

NOTICE

Pressure switches have a normal service life of 10-15 years. However, the service life may be significantly reduced by local environmental conditions.



TECHNICAL DATA

RETARD CHAMBER MODEL C-1

The Viking Corporation, 210 N Industrial Park Drive, Hastings MI 49058

Telephone: 269-945-9501 Technical Services: 877-384-5464 Fax: 269-818-1680 Email: techsvcs@vikingcorp.com

1. DESCRIPTION

The Viking Model C-1 Retard Chamber is a surge tank used with Viking Alarm Check Valves to reduce the possibility of false alarms due to changes in the water supply pressure.

Features

1. Ductile iron body
2. Self draining
3. Required Accessories:
 - a. P/N 01611A - 1/8 inch (3.2 mm) Drain Restriction (included in Viking Alarm Check Valve Trim Sets designed for use with "variable pressure" water supplies).
4. Optional Accessories:
 - a. P/N 01973A - Circuit closer vent assembly (Required when an electric Alarm Pressure Switch is installed without a Water Motor Alarm.)
 - b. Alarm Devices: A Water Motor Alarm and/or electric Alarm Pressure Switch, with approved connected alarms, are required for a complete system.



2. LISTINGS AND APPROVALS

 **cUL_{us} Listed:** VPLX and VPLX7 - 300 psi (20.7 bar) MWP

 **FM Approved:** Waterflow Alarm Valves - 300 psi (20.7 bar) MWP

 **New York City Board of Standards and Appeals:** Calendar Number 219-76-SA - 250 psi (17.2 bar) MWP

 **VdS Approved:** Wet Alarm Valve Stations - 250 psi (17.2 bar) MWP

 **LPCB Approved** - 250 psi (17.2 bar) MWP



WARNING: Cancer and Reproductive Harm-
www.P65Warnings.ca.gov

3. TECHNICAL DATA

Specifications:

Pressure Rating - 300 psi (20.7 bar) water working pressure.

Factory tested hydrostatically to 600 psi (41.4 bar).

Connections: 1/2" (15 mm) NPT inlet and 3/4" (20 mm) NPT outlet.

Capacity: 1 Gallon (4 Liters) Approx.

Material Standards:

Body: Ductile Iron 65-45-12.

Bushings: Cast Iron UNS-F12102

Coating: Viking black E-coat Spec SPF02 W01

Ordering Information:

Part Number - 05904B

Shipping Weight - 22 lbs. (10 kg.)

Available Since - 1986

Viking Technical Data may be found on
The Viking Corporation's Web site at
<http://www.vikinggroupinc.com>.
The Web site may include a more recent
edition of this Technical Data Page.

4. INSTALLATION

1. The Retard Chamber and associated trim must be installed as shown on the Viking Alarm Check Valve Trim Sheets. The trim size and arrangement shown on Viking Trim Charts is required for proper operation.
2. Circuit Closer Vent Trim must be galvanized steel unless other materials are specified in the Technical Data for the system used.
3. The 1/8 inch Drain Restriction must be installed in the Retard Chamber drain piping. The alarm supply trim piping must be restricted as shown on Viking Alarm Check Valve Trim Charts. Model J-1 Alarm Check Valve trim requires a 7/32" Restricted Orifice (Part No. 06980A).
4. The Retard Chamber must drain automatically to a non-pressurized drain.
5. For the Retard Chamber to properly drain, it must be vented. This is normally accomplished through the Water Motor Alarm connection. However, when the line to the Water Motor is trapped or an electric Alarm Pressure Switch is used without the Water Motor Alarm, Circuit Closer Vent Trim must be installed and kept clean to allow the Retard Chamber to drain.
6. Verify that all system components are rated for the water working pressure of the system.

5. OPERATION

When the clapper of the Alarm Check Valve opens, water flows through the restricted alarm supply piping into the inlet of the Retard Chamber. The Retard Chamber begins to fill while simultaneously draining through the 1/8 inch (3.2 mm) Drain Restriction.



TECHNICAL DATA

RETARD CHAMBER MODEL C-1

The Viking Corporation, 210 N Industrial Park Drive, Hastings MI 49058

Telephone: 269-945-9501 Technical Services: 877-384-5464 Fax: 269-818-1680 Email: techsvcs@vikingcorp.com

During a sustained flow of water, the Retard Chamber fills faster than water can drain through the Drain Restriction. Pressurized water fills the Retard Chamber and pressurizes the Water Motor Alarm and/or Alarm Pressure Switch. Pressure surges insufficient to overcome the volume and drain capacity of the Retard Chamber will not activate an alarm. Two Retard Chambers may be installed in series to combat false alarms from systems subject to excessive pressure surges.

6. INSPECTION, TESTS AND MAINTENANCE

NOTICE: THE OWNER IS RESPONSIBLE FOR MAINTAINING THE FIRE PROTECTION SYSTEM AND DEVICES IN PROPER OPERATING CONDITION. THE VIKING MODEL C-1 RETARD CHAMBER AND ASSOCIATED PIPING MUST BE KEPT FREE OF FOREIGN MATTER, FREEZING CONDITIONS, AND PHYSICAL DAMAGE THAT COULD IMPAIR ITS OPERATION. THE FREQUENCY OF INSPECTIONS MAY VARY DUE TO CONTAMINATED OR CORROSIVE WATER SUPPLIES, CORROSIVE ATMOSPHERES, OR ACTIVITY AROUND THE DEVICE. ALARM DEVICES AND OTHER CONNECTED EQUIPMENT MAY REQUIRE MORE FREQUENT INSPECTIONS. REFER TO APPLICABLE CODES, SYSTEM DESCRIPTION, AND TECHNICAL DATA FOR THE EQUIPMENT USED.

After installation and prior to each Waterflow Alarm Test:

1. Verify that the Alarm Check Valve and Retard Chamber are trimmed exactly as shown on Viking Trim Sheets with no deviations. The trim size and arrangement is required for proper operation.
2. Inspect and clean the 1/8 inch (3.2 mm) Drain Restriction at least annually.

After each operation and Waterflow Alarm Test:

1. Verify that the Retard Chamber and alarm line piping has drained completely and associated alarm equipment has properly reset.
2. Refer to Technical Data for the Water Motor Alarm, Alarm Pressure Switch, and other associated equipment for additional testing and maintenance requirements.

WARNING: ANY SYSTEM MAINTENANCE INVOLVING PLACING A CONTROL VALVE OR ALARM SYSTEM OUT OF SERVICE MAY ELIMINATE THE FIRE PROTECTION CAPABILITIES OF THAT SYSTEM. PRIOR TO PROCEEDING, NOTIFY ALL AUTHORITIES HAVING JURISDICTION. CONSIDERATION SHOULD BE GIVEN TO EMPLOYMENT OF A FIRE PATROL IN THE AFFECTED AREAS.

For minimum maintenance requirements, refer to NFPA 25. In addition, the Authority Having Jurisdiction may have additional maintenance requirements that must be followed.

7. AVAILABILITY

The Viking Retard Chamber is available through a network of domestic and international distributors. See the Viking Corp. Web site for closest distributor or contact The Viking Corporation.

8. GUARANTEES

For details of warranty, refer to Viking's current list price schedule or contact Viking directly.



TECHNICAL DATA

RETARD CHAMBER MODEL C-1

The Viking Corporation, 210 N Industrial Park Drive, Hastings MI 49058

Telephone: 269-945-9501 Technical Services: 877-384-5464 Fax: 269-818-1680 Email: techsvcs@vikingcorp.com

Figures 1 & 2 Notes

1. Connect alarm line piping to the 3/4" (20 mm) outlet of the Retard Chamber. When using a Water Motor Alarm, a strainer is required. When using an electric Alarm Pressure Switch only, or when the alarm line piping is trapped, Circuit Closer Vent Trim is required.
2. Items marked with * are included in the Viking Circuit Closer Vent Trim sets.

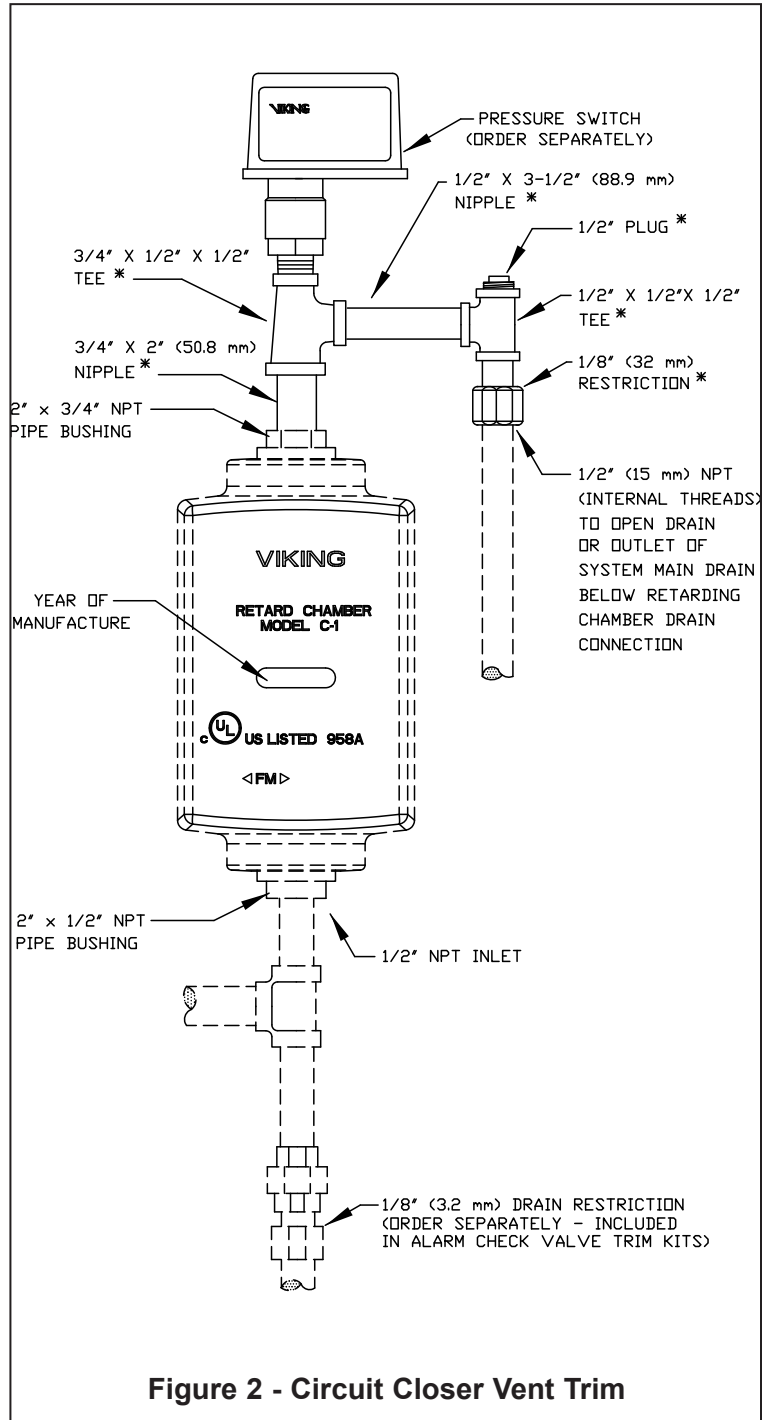
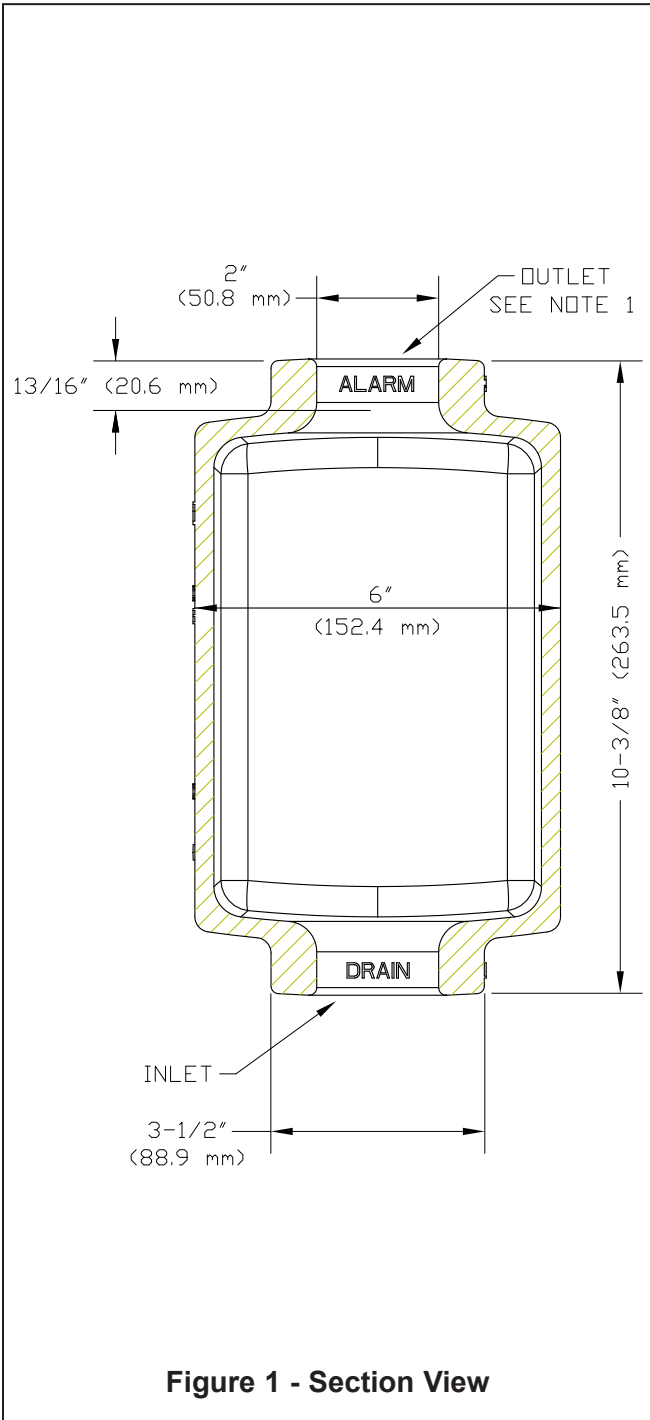



TECHNICAL DATA

DELUGE VALVE, MODEL F-1 STRAIGHT THROUGH STYLE 2-1/2" (DN65) - 8" (DN200)

The Viking Corporation, 210 N Industrial Park Drive, Hastings MI 49058

Telephone: 269-945-9501 Technical Services: 877-384-5464 Fax: 269-818-1680 Email: techsvcs@vikingcorp.com

Visit the Viking website for the latest edition of this technical data page.

1. DESCRIPTION

The Viking Model F-1 Deluge Valve is a quick opening, differential diaphragm and flood valve with one moving mechanism. The Deluge Valve is used to control water flow in Deluge and Preaction sprinkler systems. The valve is held closed by system water pressure trapped in the priming chamber; keeping the outlet chamber and system piping dry. In fire conditions, when the releasing system operates, pressure is released from the priming chamber. The Deluge Valve clapper opens to allow water to flow into the system piping.

Features:

1. Field replaceable Diaphragm and Seat Rubbers
2. Designed for installation in the horizontal or vertical position
3. Designed to be reset without opening the valve
4. Compatible with Hydraulic, Pneumatic and/or Electric Release Systems



NOTE: FOR PART NUMBERS OF ACCESSORIES, REFER TO VIKING LIST PRICE SCHEDULE.

2. LISTINGS AND APPROVALS:

U.L. Listed - Guide No. VLFT & VLJH

C-UL Listed

FM Approved - Deluge Sprinkler Systems, Preaction Sprinkler Systems, Refrigerated Area Sprinkler Systems

American Bureau of Shipping (ABS) - Certificate No. 15-HS1332725-PDA

NYC Department of Buildings - MEA 89-92-E Vol XXXI

CE - Pressure Equipment Directive 97/23/EC



WARNING: Cancer and Reproductive Harm-
www.P65Warnings.ca.gov

3. TECHNICAL DATA

Specifications:

Maximum Working Water Pressure: 250 PSI (17.4 bar)

Style: Straight through

Connections: See Table 1.

Factory tested: to 500 psi (34.5 bar)

Valve differential: 2:1 (priming chamber to inlet chamber)

Priming chamber supply restriction (required): 0.0625" (1.6 mm)

Color of Valve: Red

Friction loss: Refer to Table 1.

Cv Factor: Refer to Table 1.

Material Standards:

Refer to Figure 2.

Ordering Information:

Part Numbers - Refer to Table 1

8" - Manufactured since 2002

4" & 6" - Manufactured since 2003

2-1/2" & 3" - Manufactured since 2004

ACCESSORIES:

Refer to Current VIKING PRICE LIST for Part Numbers.

1. A Conventional Trim package for use with the Model F-1 Deluge Valve. The trim package includes the VALVE ACCESSORY PACKAGE and the fittings and nipples shown on the Viking Deluge Valve Conventional Trim Chart for the valve used. Trim Charts are provided in trim packages and the Viking website. For optional factory assembled "modular" trim packages, refer to the Viking list price schedule or contact the manufacturer.
2. A Deluge VALVE ACCESSORY PACKAGE includes required trim components. This package is needed when Viking Trim Packages are not used.
3. Auxiliary Components are required for specific valve functions. For complete operating trim requirements, refer to system data for the system used. System data is provided on the Viking website.

Additional accessories are available and may be required for system operation or supervision. Refer to the system description and technical data for complete operating trim requirements for the system used.



TECHNICAL DATA

DELUGE VALVE, MODEL F-1 STRAIGHT THROUGH STYLE 2-1/2" (DN65) - 8" (DN200)

The Viking Corporation, 210 N Industrial Park Drive, Hastings MI 49058

Telephone: 269-945-9501 Technical Services: 877-384-5464 Fax: 269-818-1680 Email: techsvcs@vikingcorp.com

Visit the Viking website for the latest edition of this technical data page.

DESCRIPTION	Nominal Size	Part Number	Friction Loss*	Cv Factor	Shipping Weight
Threaded					
Pipe O.D.					
NPT 65 mm	2½"	12401	12 ft. (3.6 m)	155	67 lbs. (30 kg)
Flange/Flange					
Flange Drilling					
ANSI	3"	12014	12 ft. (3.6 m)	155	82 lbs. (37 kg)
ANSI	4"	11953	21 ft. (6.5 m)	428	146 lbs. (66 kg)
ANSI	6"	11955	39 ft. (11.9 m)	839	271 lbs. (123 kg)
ANSI	8"	11991	57 ft. (17.4 m)	1577	466 lbs. (212 kg)
ANSI/Japan	6"	11964	39 ft. (11.9 m)	839	271 lbs. (123 kg)
PN10/16	DN80	12026	12 ft. (3.6 m)	155	82 lbs. (37 kg)
PN10/16	DN100	11965	21 ft. (6.5 m)	428	127 lbs. (58 kg)
PN10/16	DN150	11956	39 ft. (11.9 m)	839	271 lbs. (123 kg)
PN10	DN200	11995	57 ft. (17.4 m)	1577	418 lbs. (190 kg)
PN16	DN200	11999	57 ft. (17.4 m)	1577	466 lbs. (212 kg)
Flange/Groove					
Flange Drilling / Pipe O.D.					
ANSI / 89 mm	3"	12018	12 ft. (3.6 m)	155	75 lbs. (34 kg)
ANSI / 114 mm	4"	11952	21 ft. (6.5 m)	428	136 lbs. (62 kg)
ANSI / 168 mm	6"	11954	39 ft. (11.9 m)	839	261 lbs. (118 kg)
PN10/16 / 89 mm	DN80	12030	12 ft. (3.6 m)	155	75 lbs. (34 kg)
PN10/16 / 114 mm	DN100	11958	21 ft. (6.5 m)	428	136 lbs. (62 kg)
PN10/16 / 165 mm	DN150	12640	39 ft. (11.9 m)	839	261 lbs. (118 kg)
PN10/16 / 168 mm	DN150	11954	39 ft. (11.9 m)	839	261 lbs. (118 kg)
Groove/Groove					
Pipe O.D.					
73 mm	2½" / DN65	12403	12 ft. (3.6 m)	155	67 lbs. (30 kg)
76 mm	DN80	12729	12 ft. (3.6 m)	155	67 lbs. (30 kg)
89 mm	3" / DN80	12022	12 ft. (3.6 m)	155	64 lbs. (29 kg)
114 mm	4" / DN100	11513	21 ft. (6.5 m)	428	127 lbs. (58 kg)
165 mm	DN150	11910	39 ft. (11.9 m)	839	245 lbs. (111 kg)
168 mm	6" / DN150	11524	39 ft. (11.9 m)	839	245 lbs. (111 kg)
219 mm	8" / DN200	11018	57 ft. (17.4 m)	1577	403 lbs. (183 kg)

*Expressed in equivalent length of Schedule 40 pipe based on Hazen & Williams C=120

$$Q = C_v \sqrt{\frac{\Delta P}{S}}$$

Q= Flow

Cv= Flow Factor (GPM/1 PSI ΔP)

ΔP= Pressure Loss through Valve

S= Specific Gravity of Fluid

**Table 1 - Valve
Part Numbers and
Specifications**

4. INSTALLATION (Refer to Figure 1 identification of trim components.)

A. General Instruction

- Viking Straight Through Deluge Valves may be installed in the horizontal or vertical position.
- The valve must be installed in an area not subject to freezing temperatures or physical damage.
- The valve must be trimmed according to current Viking Trim Charts and appropriate instructions for the system used. Trim Charts are printed in the *Viking Engineering and Design Data* book, and are provided with trim packages.
 - Remove all plastic protectors from the openings of the Deluge Valve.
 - Apply a small amount of pipe joint compound or tape to the external threads of all pipe connections required. Take care not to allow any compound, tape, or other foreign matter inside any of the nipples or openings of the valve or trim components.
 - Viking Model F-1 Deluge Valve Conventional Trim Charts are provided with Trim Packages and in the *Viking Engineering and Design Data* book.
 - Verify that all system components are rated for the water working pressure of the system.

Hydrostatic Test:

The Model F-1 Deluge Valve is manufactured and listed for use at a maximum Water Working Pressure of 250 PSI (17.2 bar). The valve is factory tested at 500 PSI (34.5 bar). Model F-1 Deluge Valves may be hydrostatically tested at 300 PSI (20.7 bar) and/or 50 PSI (3.4 bar) above the normal Water Working Pressure, for limited periods of time (two hours), for the purpose of acceptance by the Authority Having Jurisdiction. If air testing is required, do not exceed 60-PSI (4.1 bar) air pressure.

NOTE: NEVER CONDUCT THE HYDROSTATIC TEST AGAINST THE PRESSURE OPERATED RELIEF VALVE. (P.O.R.V.) TEMPORARILY REMOVE THE P.O.R.V. FROM THE TRIM AND PLUG TRIM OPENINGS WHILE CONDUCTING THE HYDROSTATIC TEST.

TRIM NOTE: DISCHARGE PIPING FROM THE AUXILIARY DRAIN VALVE, THE FLOW TEST VALVE, AND ALL SYSTEM DRAINS SHOULD BE KEPT SEPARATE. DO NOT CONNECT THE OUTLET OF THE DRIP CHECK TO ANY OTHER DRAIN.

- The priming line must be connected upstream of the system water supply main control valve or to a constant source of water at a pressure equal to the system water supply.



TECHNICAL DATA

**DELUGE VALVE, MODEL F-1
STRAIGHT THROUGH STYLE**
2-1/2" (DN65) - 8" (DN200)

The Viking Corporation, 210 N Industrial Park Drive, Hastings MI 49058

Telephone: 269-945-9501 Technical Services: 877-384-5464 Fax: 269-818-1680 Email: techsvcs@vikingcorp.com

Visit the Viking website for the latest edition of this technical data page.

5. After the Deluge Valve is set, operation of the Deluge Valve requires the release of priming water from the priming chamber. This may be by automatic or manual operation of the release system. Viking Deluge Valves are compatible with hydraulic, pneumatic, and electric release systems. For specific Trim arrangements refer to Trim Charts and System Data describing the system being installed. Trim Charts are printed in the *Viking Engineering and Design Data* book, and are provided with trim packages. System Data sheets are printed in the *Viking Engineering and Design Data* book.
 - a. Hydraulic Release Systems: See Figures 3-6 for the maximum allowable elevation of hydraulic release piping above the Deluge Valve. If the maximum height of hydraulic release piping exceeds the limit shown in Figures 3-6 for the valve used, use a Pneumatic or Electric Release System.
 - b. Pneumatic Release Systems: A Viking Pneumatic Actuator is required between the release system connection provided on deluge valve trim and pneumatic release system piping.
 - c. Electric Release Systems: Solenoid Valves, System Control Panels, and Electrical Detectors must be compatible. Consult appropriate listing and/or approval guides.

NOTE: FOR OPERATION AT WATER PRESSURES IN EXCESS OF 175 PSI (12.1 BAR), A 250 PSI (17.2 BAR) RATED SOLENOID VALVE MUST BE USED. REFER TO APPROPRIATE VIKING TECHNICAL DATA PAGE FOR TYPE OF SYSTEM USED.

▲ CAUTION

Operation of Viking Deluge Valves by pressurizing the priming chamber with air pressure or any other pressurized gas is not recommended or approved.

B. Placing the Valve in Service

For Deluge Valves equipped with Conventional Deluge Valve Trim, follow steps 1 through 10 (and 11 & 12 if applicable) below.

1. Verify:
 - a. The system Main Water Supply Control Valve (D.1) is closed and the Deluge Valve is trimmed according to current Viking Trim Charts and schematic drawings for the system used.
 - b. The system has been properly drained.
 - c. Auxiliary Drain (B.13) is open.
 - d. The Emergency Release (B.9) is closed.
 - e. The system water supply piping is pressurized up to the closed Main Water Supply Control Valve (D.1) and the priming line is pressurized up to the closed Priming Valve (B.1).
2. For Systems equipped with:
 - a. Hydraulic Release Systems:
 - i. Verify that all releasing devices are set and that any Inspector's Test Valve and/or auxiliary drain valves are closed.
 - ii. Open Priming Valve (B.1). Allow the hydraulic release system to fill. When priming pressure gauge (B.7) indicates that the release piping and priming chamber pressure is equal to system supply pressure, proceed to step 3.
 - iii. Proceed to step 3.
 - b. Pneumatic Release Systems:
 - i. Set the release system.
 - ii. Open Priming Valve (B.1).
 - iii. Proceed to step 3.
 - c. Electric Release Systems:
 - i. Open Priming Valve (B.1).
 - ii. Set the electric release system.
 - iii. Proceed to step 3.
3. Open Flow Test Valve (B.11).
4. Partially open Main Water Supply Control Valve (D.1).
5. When full flow develops from the Flow Test Valve (B.11), close the Flow Test Valve. Verify that there is no flow from the open Auxiliary Drain (B.13).
6. Close Auxiliary Drain (B.13).
7. Fully open and secure the Main Water Supply Control Valve (D.1).
8. Verify that the Alarm Shut-off Valve (B.6) is open and that all other valves are in their normal** operating position.
9. Depress the plunger of Drip Check (B.14). No water should flow from the Drip Check when the plunger is pushed.
10. Check for, and repair all leaks.
11. On new installations, those systems that have been placed out of service, or where new equipment has been installed, trip test the system to verify that all equipment functions properly. Refer to INSPECTION, TESTS AND MAINTENANCE paragraph 6-II-C: ANNUAL Trip Test instructions.

▲ CAUTION

Performing a trip test results in operation of the Deluge Valve. Water will flow into the sprinkler piping. Take necessary precautions to prevent damage.



TECHNICAL DATA

DELUGE VALVE, MODEL F-1 STRAIGHT THROUGH STYLE 2-1/2" (DN65) - 8" (DN200)

The Viking Corporation, 210 N Industrial Park Drive, Hastings MI 49058

Telephone: 269-945-9501 Technical Services: 877-384-5464 Fax: 269-818-1680 Email: techsvcs@vikingcorp.com

Visit the Viking website for the latest edition of this technical data page.

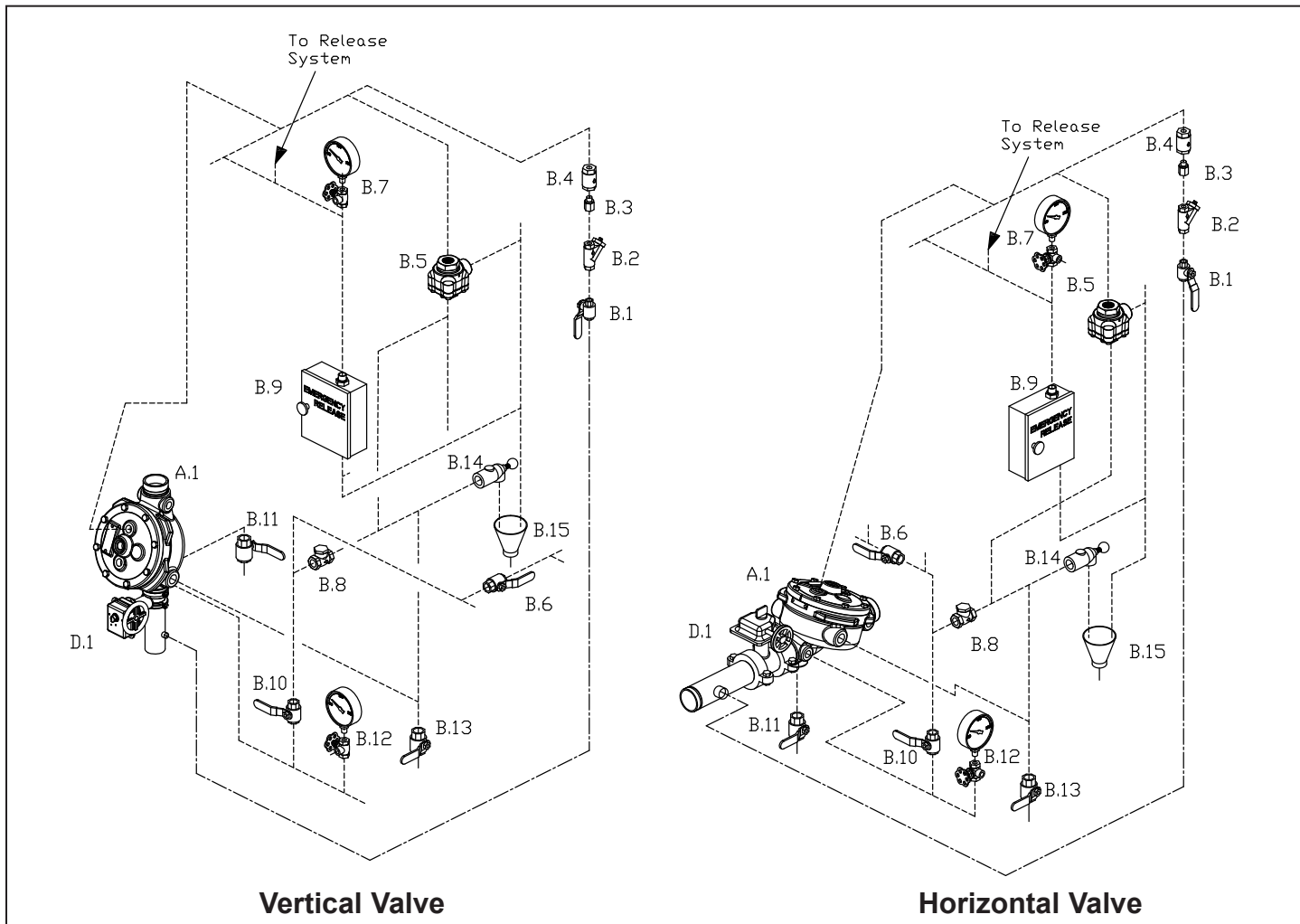

----- Dashed lines indicate nipples and fittings included with trim.

----- Phantom lines indicate piping required, but not included with trim.

Figure 1 - Conventional Trim Components

A.1	Deluge Valve	B.9	Emergency Release
B.1	Priming Valve (Normally Open)	B.10	Alarm Test Valve (Normally Closed)
B.2	Strainer	B.11	Flow Test Valve (Normally Closed)
B.3	1/16" Restricted Orifice	B.12	Water Supply Pressure Water Gauge and Valve
B.4	Spring Loaded Check Valve	B.13	Auxiliary Drain Valve (Normally Closed)
B.5	Pressure Operated Relief Valve (PORV)	B.14	Drip Check Valve
B.6	Alarm Shut Off Valve (Normally Open)	B.15	Drain Cup
B.7	Priming Pressure Water Gauge and Valve	D.1	Water Supply Control Valve
B.8	Drain Check Valve		



TECHNICAL DATA

**DELUGE VALVE, MODEL F-1
STRAIGHT THROUGH STYLE**
2-1/2" (DN65) - 8" (DN200)

The Viking Corporation, 210 N Industrial Park Drive, Hastings MI 49058

Telephone: 269-945-9501 Technical Services: 877-384-5464 Fax: 269-818-1680 Email: techsvcs@vikingcorp.com

Visit the Viking website for the latest edition of this technical data page.

After completing a trip test, perform SEMI-ANNUAL maintenance.

C. Valve Removed From Service

NOTE: WHEN A VALVE HAS BEEN REMOVED FROM SERVICE AND IS SUBJECT TO FREEZING OR WILL BE OUT OF SERVICE FOR AN EXTENDED PERIOD OF TIME, ALL WATER MUST BE REMOVED FROM THE PRIMING CHAMBER, TRIM PIPING, WATER SUPPLY PIPING AND OTHER TRAPPED AREAS.

5. OPERATION (Refer to Figure 2.)

The Viking Model F-1 Deluge Valve has an inlet chamber, an outlet chamber and a priming chamber. The inlet chamber and outlet chamber are separated from the priming chamber by the clapper (5) and diaphragm (6).

In the set condition:

System pressure is supplied to the priming chamber through a restricted priming line (trim) equipped with a check valve. System water supply pressure trapped in the priming chamber holds the clapper (5) on seat (2) due to area differential design. Clapper (5) separates the inlet chamber from the outlet chamber, keeping the outlet chamber and system piping dry.

In fire conditions:

When the release system operates, pressure is released from the priming chamber faster than it is supplied through the restricted priming line. Water supply pressure in the inlet chamber forces the clapper (5) off from seat (2), allowing water to flow through the outlet and into the system and alarm devices.

For Deluge Valves equipped with Conventional Trim:

When the deluge valve operates, the air side of the PORV loses pressure, causing the PORV to operate. When the PORV operates, it continually vents the priming chamber to prevent the deluge valve from resetting even if the open releasing devices close. The deluge valve can only be reset after the system is taken out of service, and the outlet chamber of the deluge valve and associated trim piping is depressurized and drained.

6. INSPECTIONS, TESTS AND MAINTENANCE

I. Inspection

It is imperative that the system is inspected and tested on a regular basis. The frequency of the inspections may vary due to contaminated water supplies, corrosive water supplies or corrosive atmospheres. Also, the alarm devices, detection systems or other connected trim may require a more frequent schedule. For minimum maintenance and inspection requirements, refer to NFPA 25. In addition, the Authority Having Jurisdiction may have additional maintenance, testing, and inspection requirements that must be followed. The following recommendations are minimum requirements. (For additional information, refer to Viking Trim Charts and System Data describing systems with the release system used.)

A. Weekly:

Weekly visual inspection of the Viking Deluge Valve is recommended.

1. Verify that the Main Water Supply Control Valve (D.1) is open and that all other valves are in their normal** operating position and appropriately secured.
2. Check for signs of mechanical damage, leakage, and/or corrosive activity. If detected, perform maintenance as required. If necessary, replace the device.
3. Verify that the valve and trim are adequately heated and protected from freezing and physical damage.

II. Tests

A. Quarterly Water Flow Alarm Test

1. Notify the Authority Having Jurisdiction and those in the area affected by the test.
2. To test the local electric alarm (if provided) and/or mechanical water motor alarm (if provided), OPEN the alarm test valve (B.10) in the deluge valve trim.
 - a. Electric alarm pressure switches (if provided) should activate.
 - b. Electric local alarms should be audible.
 - c. The local water motor gong should be audible.
 - d. If equipped with remote station alarm signaling devices, verify that alarm signals were received.
3. When testing is complete, CLOSE the alarm test valve (B.10).
4. Verify:
 - a. All local alarms stop sounding and alarm panels (if provided) reset.
 - b. All remote station alarms reset.
 - c. Supply piping to water motor alarm properly drains.
5. Verify that the alarm shut-off valve (B.6) is OPEN, and the alarm test valve (B.10) is CLOSED.
6. Verify that the outlet chamber is free of water. No water should flow from the drip check (B.14) when the plunger is pushed.
7. Notify the Authority Having Jurisdiction and those in the affected area that testing is complete.



TECHNICAL DATA

**DELUGE VALVE, MODEL F-1
STRAIGHT THROUGH STYLE**
2-1/2" (DN65) - 8" (DN200)

The Viking Corporation, 210 N Industrial Park Drive, Hastings MI 49058

Telephone: 269-945-9501 Technical Services: 877-384-5464 Fax: 269-818-1680 Email: techsvcs@vikingcorp.com

Visit the Viking website for the latest edition of this technical data page.

B. Quarterly Main Drain Test

1. Notify the Authority Having Jurisdiction and those in the area affected by the test.
2. Record pressure reading from the water supply pressure gauge (B.12).
3. Verify that the outlet chamber of the deluge valve is free of water. No water should flow from the drip check (B.7) when the plunger is pushed.
4. Fully OPEN the flow test valve (B.11).
5. When a full flow is developed from the flow test valve (B.11), record the residual pressure from the water supply pressure gauge (B.12).
6. When the test is complete, SLOWLY CLOSE the flow test valve (B.11).
7. Compare test results with previous flow information. If deterioration of the water supply is detected, take appropriate steps to restore adequate water supply.
8. Verify:
 - a. Normal water supply pressure has been restored to the inlet chamber, the priming chamber, and the release system. The pressure on the priming chamber water pressure gauge should equal the system water supply pressure.
 - b. All alarm devices, and valves are secured in normal** operating position.
9. Notify the Authority Having Jurisdiction that the test is complete. Record and/or provide notification of test results as required by the Authority Having Jurisdiction.

** For normal operating position, refer to Figure 1 and/or Trim Charts and System Data for the system used.

C. Annual Trip Test:

▲ CAUTION

Performing this test results in operation of the Deluge Valve. Water will flow into the sprinkler piping and from any open sprinklers and/or nozzles. Take necessary precautions to prevent damage.

1. Notify the Authority Having Jurisdiction and those in the area affected by the test.
2. Fully open the flow test valve (B.11) to flush away any accumulation of foreign material.
3. Close the flow test valve (B.11).
4. Trip the system by operating the release system. Allow a full flow to pass through the deluge valve. Water flow alarms should operate.
5. When test is complete:
 - a. Close the main water supply control valve (D.1).
 - b. Close the priming valve (B.1).
 - c. Open the auxiliary drain valve (B.13).
 - d. Open all system main drains and auxiliary drains. Allow the system to drain completely.
6. Perform SEMI-ANNUAL maintenance. Refer to paragraph 6.III.B SEMI-ANNUAL MAINTENANCE.
7. Place the system in service. Refer to Item 4.B, INSTALLATION: PLACING THE VALVE IN SERVICE.

NOTE: DELUGE VALVES SUPPLIED BY BRACKISH WATER, SALT WATER, FOAM, FOAM/WATER SOLUTION, OR ANY OTHER CORROSIVE WATER SUPPLY, SHOULD BE FLUSHED WITH GOOD QUALITY FRESH WATER BEFORE BEING RETURNED TO SERVICE.

8. Notify the Authority Having Jurisdiction that the test is complete. Record and/or provide notification of test results as required by the Authority Having Jurisdiction.

III. Maintenance

NOTICE

The owner is responsible for maintaining the fire protection system and devices in proper operating condition. The Deluge Valve must be kept from freezing conditions and physical damage that could impair its operation.

▲ WARNING

Any system maintenance which involves placing a control valve or detection system out of service may eliminate the Fire Protection capabilities of that system. Prior to proceeding, notify all Authorities Having Jurisdiction. Consideration should be given to employment of a Fire Patrol in the affected areas.

Where difficulty in performance is experienced, the valve manufacturer or authorized representative shall be contacted if any field adjustment is to be made.

A. After Each Operation:

1. Sprinkler systems that have been subjected to a fire must be returned to service as soon as possible. The entire system must be inspected for damage, and repaired or replaced as necessary.
2. Deluge Valves and trim that have been subjected to brackish water, salt water, foam, foam/water solution, or any other corrosive water supply should be flushed with good quality fresh water before being returned to service.
3. Perform SEMI-ANNUAL maintenance after every operation.



TECHNICAL DATA

**DELUGE VALVE, MODEL F-1
STRAIGHT THROUGH STYLE**
2-1/2" (DN65) - 8" (DN200)

The Viking Corporation, 210 N Industrial Park Drive, Hastings MI 49058

Telephone: 269-945-9501 Technical Services: 877-384-5464 Fax: 269-818-1680 Email: techsvcs@vikingcorp.com

Visit the Viking website for the latest edition of this technical data page.

B. Semi-Annual Maintenance:

1. Remove the system from service. (Refer to Deluge or Preaction System Data that describes systems with the release system used for additional information.)
 - a. Close the Main Water Supply Control Valve (D.1) and Priming Valve (B.1).
 - b. Open the Auxiliary Drain Valve (B.13).
 - c. Relieve pressure in the priming chamber by opening the Emergency Release Valve (B.9).
4. Inspect all trim for signs of corrosion and/or blockage. Clean and/or replace as required.
5. Clean and/or replace all strainer screens (including B.2).
6. Refer to Item 4-B, INSTALLATION: PLACING THE VALVE IN SERVICE.

C. Every Fifth Year

1. Internal inspection of Deluge Valves is recommended every five years unless inspections and tests indicate more frequent internal inspections are required. Refer to DISASSEMBLY instructions provided below.
2. Internal inspection of strainers and restricted orifices is recommended every five years unless inspections and tests indicate more frequent internal inspections are required.
3. Record and provide notification of inspection results as required by the Authority Having Jurisdiction.

D. Valve Disassembly (Refer to Figure 2)

1. Remove the valve from service (see the release system description and Technical Data for additional information). Close the main control valve and open the main drain valve. Release the pressure in the priming chamber by opening the Emergency Release Valve.
2. Remove trim as required to allow removal of cover (4).
3. Remove screws (9).
4. Lift cover (4) from body (1).
5. Remove clapper assembly (No. 3, 5, 6, 7, 9, 10, 11) by lifting it from the body (1).
6. Inspect seat (2). If replacement is necessary, remove screws (12). Remove old seat (2) and o-ring (13). Replace with new seat (2) and o-ring (13). Replace screws (12).
7. To replace the diaphragm rubber (6), remove the circle of screws (10). Remove the clamp ring (3) and remove the diaphragm rubber (6).
8. To replace the seat rubber assembly (7), clapper assembly (3, 5, 6, 7, 9, 10, 11) must be removed from the valve. Remove the circle of screws (12). Seat rubber assembly (7) can be removed.

NOTE: PRIOR TO INSTALLING A NEW CLAPPER RUBBER (6) OR SEAT RUBBER ASSEMBLY (7), MAKE CERTAIN THAT ALL SURFACES ARE CLEAN AND FREE OF FOREIGN MATTER. THE PLATED SEAT (2) MUST BE SMOOTH AND FREE OF NICKS, BURRS OR INDENTATIONS.

E. Valve Reassembly

1. Prior to reassembly, flush the valve of all foreign matter.
2. To reassemble, reverse disassembly procedure.

7. AVAILABILITY

The Viking Model F-1 Deluge Valve is available through a network of domestic and international distributors. See the Viking Corp. Web site for closest distributor or contact The Viking Corporation.

8. GUARANTEES

For details of warranty, refer to Viking's current list price schedule or contact Viking directly.



TECHNICAL DATA

DELUGE VALVE, MODEL F-1 STRAIGHT THROUGH STYLE 2-1/2" (DN65) - 8" (DN200)

The Viking Corporation, 210 N Industrial Park Drive, Hastings MI 49058
 Telephone: 269-945-9501 Technical Services: 877-384-5464 Fax: 269-818-1680 Email: techsvcs@vikingcorp.com
 Visit the Viking website for the latest edition of this technical data page.

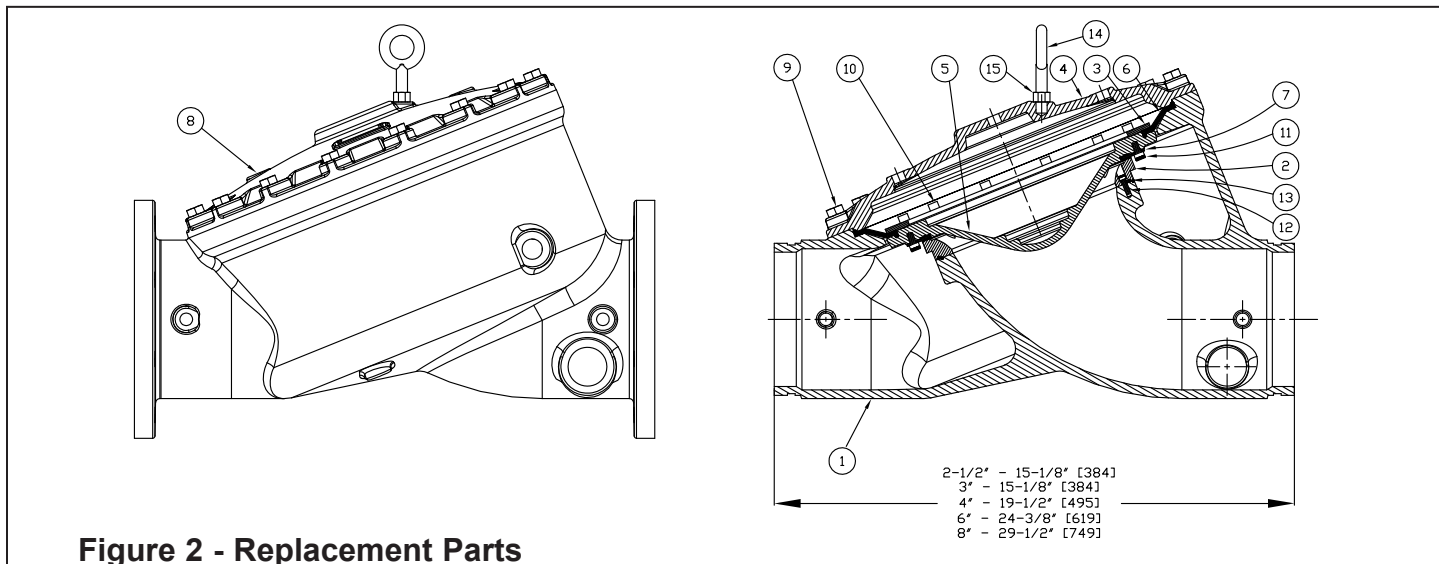

Figure 2 - Replacement Parts

ITEM NO.	PART NUMBER				DESCRIPTION	MATERIAL	NO. REQ'D.			
	2-1/2" (DN65) & 3" (DN80)	4" (DN100)	6" (DN150)	8" (DN200)			2-1/2" (DN65) & 3" (DN80)	4" (DN100)	6" (DN150)	8" (DN200)
1	--	--	--	--	Body	Ductile Iron	1	1	1	1
2	*	*	*	*	Seat	Brass	1	1	1	1
3	02493B	02378B	05704B	10514	Ring Clamp, Upper Diaphragm	Brass Casting	1	1	1	1
4	--	--	--	--	Cover	Ductile Iron 65-45-12	1	1	1	1
5	08846N	08844N	08570N	10518N/B	Clapper	Ductile Iron 65-45-12, PTFE Powder Coated	1	1	1	1
6	12012	11560	11561	10510	Upper Diaphragm	EPDM - ASTM D-2000	1	1	1	1
7	02497B	02382B	02176B	10512	Rubber Seat Assembly	EPDM - ASTM D-2000	1	1	1	1
8	--	--	--	--	Data Plate	Aluminum Etched	1	1	1	1
9	02169A				Screw, H.H.C. ¹ , 1/2-13 x 1-1/4 (32)	Steel, SAE-Grade 5, ASTM A449	10			
		02200A			Screw, H.H.C. ¹ , 1/2-13 x 1 1/2 (38)	Steel, SAE-Grade 5, ASTM A307-90		12		
			05707A	05707A	Screw, H.H.C. ¹ , 5/8-11 x 1 3/4 (44)	Steel, SAE Grade 5, ASTM A307-90			15	16
10	02496A				Screw, R.H. ³ , 10-24 x 3/8 (9.5)	Stainless Steel UNS-S30200	6			
		02383A			Screw, H.H.C. ¹ , 5/16-18 x 1/2 (13)	Stainless Steel UNS-S30400		8		
			07932		Screw, H.H.C. ¹ , 3/8-16 x 1/2 (13)	Stainless Steel UNS-S30400			12	
				11022	Screw, S.H.C. ² , 3/8-16 x 3/4 (19.1)	Stainless Steel UNS-S31600				12
11	02494A				Screw, R.H. ³ , 10-24 x 1/2 (12.7)	Stainless Steel UNS-S30200	6			
		02383A			Screw, H.H.C. ¹ , 5/16-18 x 1/2 (13)	Stainless Steel UNS-S30400		6		
			02454A		Screw, H.H.C. ¹ , 3/8-16 x 5/8 (16)	Stainless Steel UNS-S30400			12	
12				11021	Screw, S.H.C. ² , 3/8-16 x 1/2 (12.7)	Stainless Steel UNS-S30400				12
	*				Screw, R.H. ³ , 10-24 x 5/8 (16)	Stainless Steel UNS-S30200	4			
		*			Screw, H.H.C. ¹ , 5/16-18 x 1/2 (13)	Stainless Steel UNS-S30400		8		
13		*	*	*	Screw, S.H.C. ² , 1/4-20 x 3/4 (19.1)	Stainless Steel UNS-S31600			8	6
	*	*	*	*	O-Ring	EPDM	1	1	1	1
14	--	--	--	11570	Eye Bolt, 5/8-11-UNC	Carbon Steel				1
15				F01256	Nut, 5/8-11-UNC	Stainless Steel				1

-- Indicates replacement part not available

* Indicates part available only in sub-assembly listed below

SUB-ASSEMBLY

2, 12, 13	14711-3	14711-4	14711-6	14711-8	Seat Replacement Kit*
3, 5-7, 9-11	13488	13490	13492	13484	Clapper Assembly Kit

*Note: Includes o-ring lubricant to be added to ring groove in seat.

¹ Hex Head Cap Screw

² Socket Head Cap Screw, (8" Valve - #10 & 11 must be S.H.C. for clearance with seat)

³ Round Head, Phillips Drive Screw



TECHNICAL DATA

**DELUGE VALVE, MODEL F-1
STRAIGHT THROUGH STYLE**
2-1/2" (DN65) - 8" (DN200)

The Viking Corporation, 210 N Industrial Park Drive, Hastings MI 49058
 Telephone: 269-945-9501 Technical Services: 877-384-5464 Fax: 269-818-1680 Email: techsvcs@vikingcorp.com
 Visit the Viking website for the latest edition of this technical data page.

Maximum Allowable Pilot Heights for Select Equivalent Lengths of Hydraulic Release Piping.
 For valves with 1/16" (1.6 mm) Restricted Orifice

Graphs are based on 1/2" (15 mm) pilot sprinklers installed on 1/2" (15 mm) Schedule 40 galvanized released piping.

If the maximum height of hydraulic release piping exceeds the limits shown on the graph, use pneumatic or electric release system

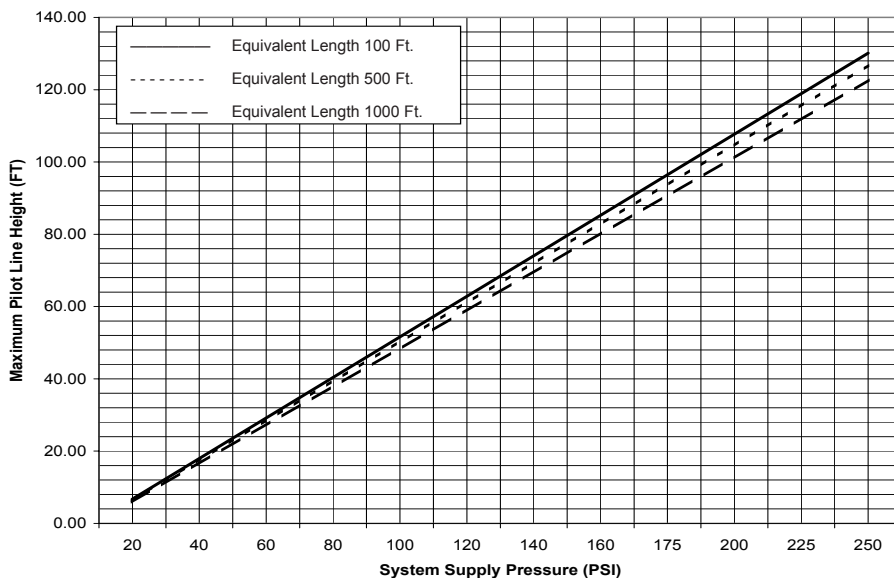

Figure 3 - 2-1/2" (DN65) & 3" (DN80) Model F-1 Deluge Valves

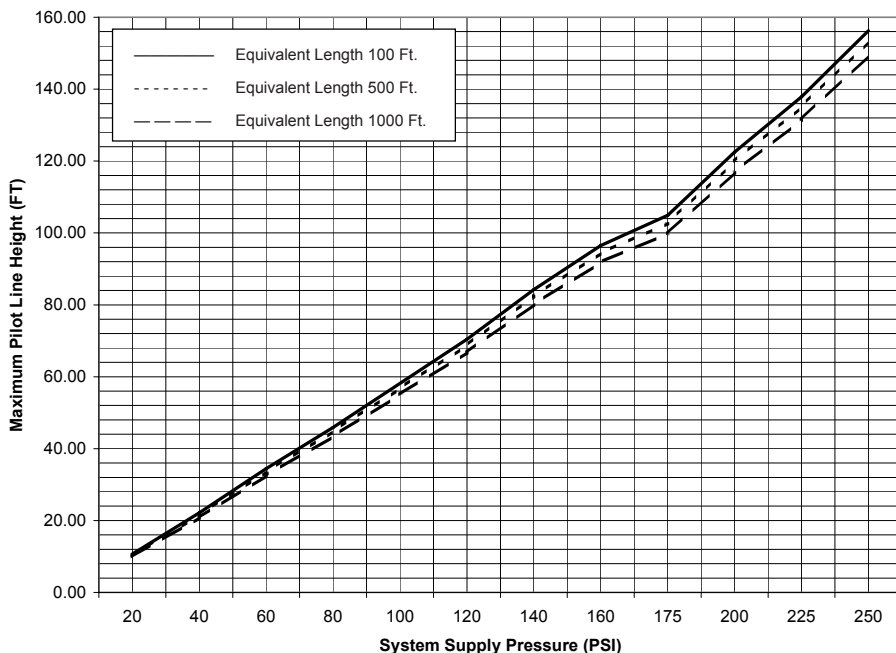

Figure 4 - 4" (DN100) Model F-1 Deluge Valves



TECHNICAL DATA

**DELUGE VALVE, MODEL F-1
STRAIGHT THROUGH STYLE**
2-1/2" (DN65) - 8" (DN200)

The Viking Corporation, 210 N Industrial Park Drive, Hastings MI 49058
 Telephone: 269-945-9501 Technical Services: 877-384-5464 Fax: 269-818-1680 Email: techsvcs@vikingcorp.com
 Visit the Viking website for the latest edition of this technical data page.

Maximum Allowable Pilot Heights for Select Equivalent Lengths of Hydraulic Release Piping.

For valves with 1/16" (1.6 mm) Restricted Orifice

Graphs are based on 1/2" (15 mm) pilot sprinklers installed on 1/2" (15 mm) Schedule 40 galvanized released piping.

If the maximum height of hydraulic release piping exceeds the limits shown on the graph, use pneumatic or electric release system

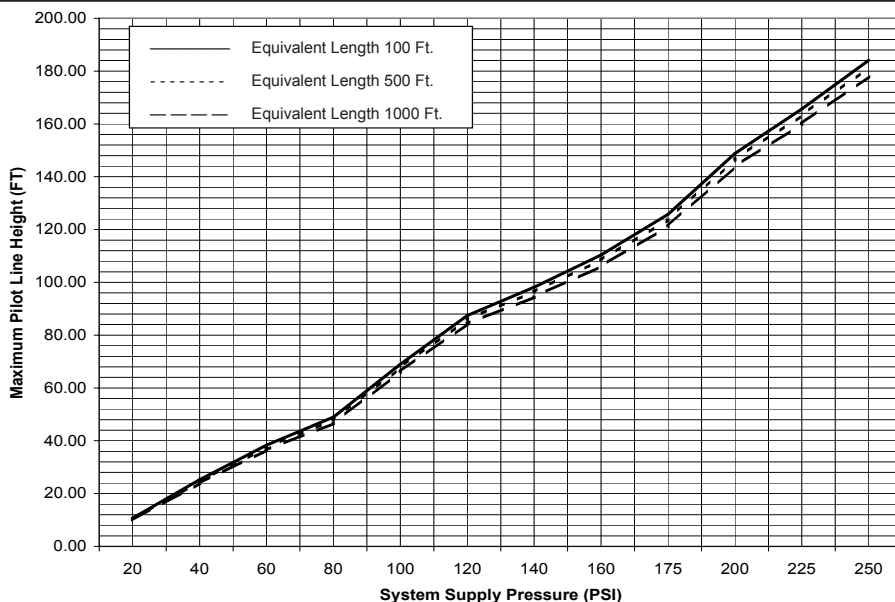

**Figure 5 - 6" (DN150)
Model F-1 Deluge Valves**

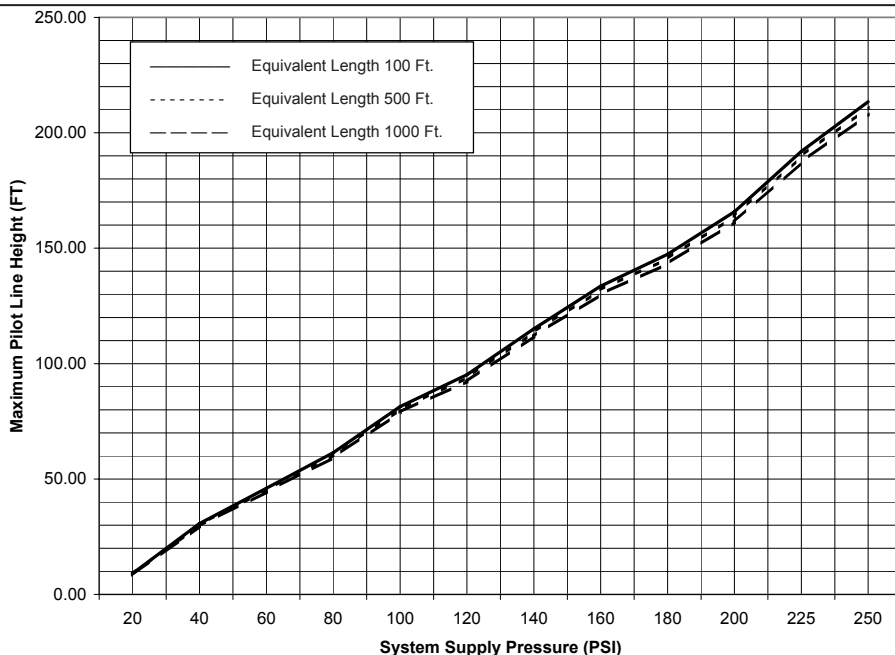

**Figure 6 - 8" (DN200)
Model F-1 Deluge Valves**



TECHNICAL DATA

CONCENTRATE CONTROL VALVE APPLICATIONS, PRIMING CONNECTIONS, AND TRIMS

The Viking Corporation, 210 N Industrial Park Drive, Hastings MI 49058

Telephone: 269-945-9501 Technical Services: 877-384-5464 Fax: 269-818-1680 Email: techsvcs@vikingcorp.com

Visit the Viking website for the latest edition of this technical data page www.vikinggroupinc.com

1. GENERAL DESCRIPTION

The Halar® Coated Concentrate Control Valve (CCV) is utilized in Viking foam systems as a positive shut-off valve for the foam concentrate supplied either from a bladder tank or a foam pump. The CCV valve opens automatically when there is a water flow in the sprinkler system. This allows concentrate to flow through the proportioning device to create foam solution.

A. Standard Foam Deluge, Foam Preaction, and Foam Flow Control Systems (See Figure 4)

The CCV valve is a straight through Halar® coated deluge. The priming connection can be part of the riser control valve trim, (conventional deluge or flow control trim). When the priming connection to the CCV is located on the primary riser valve trim, the priming supply connection to the CCV is located prior to the release trim. The actual supply inlet to the CCV should be connected to an open connection port on the cover of the deluge or flow control valve. The 1/2" pipe plugs installed in the cover of the deluge or flow control valve may be removed and piping from the valve cover can be connected to the priming chamber of the CCV or an outlet can be created prior to the release device (solenoid or pneumatic actuator) on the valve trim. When the deluge or flow control valve activates, the priming water in the deluge or flow control valve and the CCV are released simultaneously allowing both valves to open. Priming water pressure will be drained through the deluge or flow control valve trim. The valves will remain open until the system is reset. Refer to design data pages for re-setting instructions.

B. Wet Foam Systems (See Figure 3)

The CCV valve is a straight through Halar® coated deluge or flow control valve. Where the CCV is used in conjunction with a wet foam system a separate primary priming connection is required. The separate priming connection will consist of a 1/2" ball valve, 1/2" "Y" strainer, 1/8" restricted orifice, 1/2" spring loaded check valve, and Pressure Operated Relief Valve (PORV). The priming water supply to the CCV is taken upstream of the riser control valve. The priming supply feeds through the system to the priming chamber of the CCV. The sensing side of the PORV is connected to the alarm connection of the Alarm Valve. When water flow is present through the sprinkler riser, water flows from the alarm connection to the sensing side of the PORV, the PORV opens which drains the CCV priming chamber allowing it to open. Foam concentrate will discharge from the CCV to the proportioning device until water pressure is removed from the sensing side of the PORV. Note that the PORV 1/2" drain will operate when the system is activated. The PORV must be piped to an open drain.

2. LISTINGS AND APPROVALS

UL Listed - Deluge Valve EX2006

FM Approved - FM5130, 1020

LPCB

Refer to the individual technical data sheets for the components within the system.

3. TECHNICAL DATA

3.1 Specifications:

Refer to individual component technical data pages for PORV, Pressure Switch, Solenoid Valve, and Deluge Valves.

3.2 Material Standards:

Refer to individual component technical data page.

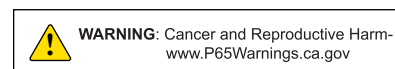



TECHNICAL DATA

CONCENTRATE CONTROL VALVE APPLICATIONS, PRIMING CONNECTIONS, AND TRIMS

The Viking Corporation, 210 N Industrial Park Drive, Hastings MI 49058
 Telephone: 269-945-9501 Technical Services: 877-384-5464 Fax: 269-818-1680 Email: techsvcs@vikingcorp.com
 Visit the Viking website for the latest edition of this technical data page www.vikinggroupinc.com

3.3 Ordering Information:

Table 3.3.1: Ordering Information

HALAR® COATED CONCENTRATE CONTROL VALVES											TRIM KIT PART NUMBERS	
Valve Style	Valve Model	Deluge Part No.	Valve Size Nominal	Inlet Type	Outlet Type	Pipe O.D. Actual	Flange Drilling	Friction Loss*	Cv Factor	Shipping Weight	Galvanized & Brass	Brass only
Straight Through	F-2	12127Q/B	1½" (DN40)	Grooved	Grooved	1 ²⁹ / ₃₂ " (48.3 mm)	--	7 ft. (2.1 m)	66	36 lbs. (16.3 kg)	12848-1	12848-2
	F-2	12058Q/B	2" (DN50)	Grooved	Grooved	2 ³ / ₈ " (60.3 mm)	--	13 ft. (3.9 m)	93	36.5 (16.5 kg)	12848-1	12848-2
	F-2	12404Q/B	2½" (DN65)	Grooved	Grooved	2 ⁷ / ₈ " (73 mm)	--	12 ft. (3.6 m)	155	66 lbs. (30 kg)	12929-1	12929-2
	F-2	12730Q/B	DN65	Grooved	Grooved	76 mm	--	12 ft. (3.6 m)	155	66 lbs. (30 kg)		
	F-2	12015Q/B	3" (DN80)	Flanged	Flanged	3½" (88.9 mm)	ANSI B16.42 Class 150	12 ft. (3.6 m)	228	82 lbs. (37 kg)		
	F-2	12019Q/B	3" (DN80)	Flanged	Grooved	3½" (88.9 mm)	ANSI B16.42 Class 150	12 ft. (3.6 m)	228	73 lbs. (33.1 kg)		
	F-2	12023Q/B	3" (DN80)	Grooved	Grooved	88.9 mm		12 ft. (3.6 m)	228	64 lbs. (29 kg)		

* Expressed in equivalent length of pipe based on Hazen & Williams Formula C=120.

4. INSTALLATION

Refer to specific technical data sheets, acceptable installation standards, codes and Authority Having Jurisdiction for additional installation, operation and maintenance instructions.

5. OPERATION

Refer to individual component technical data page.

6. INSPECTIONS, TESTS AND MAINTENANCE

NOTICE

The owner is responsible for maintaining the fire protection system and devices in proper operating condition. For minimum maintenance and inspection requirements, refer to recognized standards such as those produced by NFPA, LPC, and VdS which describe care and maintenance of sprinkler systems. In addition, the Authority Having Jurisdiction may have additional maintenance, testing and inspection requirements which must be followed.

⚠ WARNING

Any system maintenance or testing that involves placing a control valve or detection system out of service may eliminate the fire protection of that system. Prior to proceeding, notify all Authorities Having Jurisdiction. Consideration should be given to employment of a fire patrol in the affected area.

It is imperative that the system is inspected and tested on a regular basis. The frequency of the inspections may vary due to contaminated or corrosive water supplies and corrosive atmospheres. In addition, the alarm devices or other connected equipment may require more frequent inspections. Refer to the technical data, system description, applicable codes and Authority Having



TECHNICAL DATA

CONCENTRATE CONTROL VALVE APPLICATIONS, PRIMING CONNECTIONS, AND TRIMS

The Viking Corporation, 210 N Industrial Park Drive, Hastings MI 49058

Telephone: 269-945-9501 Technical Services: 877-384-5464 Fax: 269-818-1680 Email: techsvcs@vikingcorp.com

Visit the Viking website for the latest edition of this technical data page www.vikinggroupinc.com

Jurisdiction for minimum requirements.

7. AVAILABILITY

The product is available directly from Viking and official distributors only.

Americas:

The Viking Corporation
5150 Beltway SE
Caledonia, MI 49316
Tel.: (800) 968-9501
Fax: 269-818-1680
Technical Services: 1-877-384-5464
techsvcs@vikingcorp.com

EU:

Viking S.A.
21, Z.I. Haneboesch
L-4562 Differdange / Nieder Korn
Tel.: +352 58 37 37 - 1
Fax: +352 58 37 36
vikinglux@viking-emea.com

Asia Pacific (APAC) Main Office:

The Viking Corporation (Far East) Pte. Ltd.
69 Tuas View Square
Westlink Techpark, Singapore 637621
Tel: (+65) 6 278 4061
Fax: (+65) 6 278 4609
vikingAPAC@vikingcorp.com

8. GUARANTEE

For details of warranty, refer to Viking's current list price schedule or contact Viking directly.

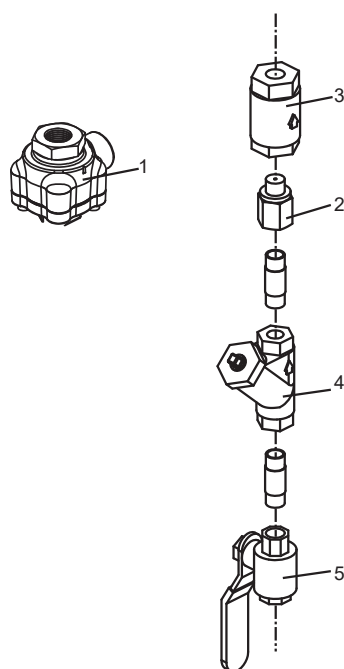

Table 2: Priming Line Connection Package (PN 10985) Components

REF.	DESCRIPTION
1	1/2" Pressure Operated Relief Valve (PORV)
2	1/8" Restricted Orifice
3	1/2" Swing Check Valve
4	1/2" Y-Strainer
5	1/2" Ball Valve

Figure 1 - Priming Connection Package Components

NOTE: All components shown here are included with the Priming Connection Package (PN 10985)



TECHNICAL DATA

CONCENTRATE CONTROL VALVE APPLICATIONS, PRIMING CONNECTIONS, AND TRIMS

The Viking Corporation, 210 N Industrial Park Drive, Hastings MI 49058
 Telephone: 269-945-9501 Technical Services: 877-384-5464 Fax: 269-818-1680 Email: techsvcs@vikingcorp.com
 Visit the Viking website for the latest edition of this technical data page www.vikinggroupinc.com

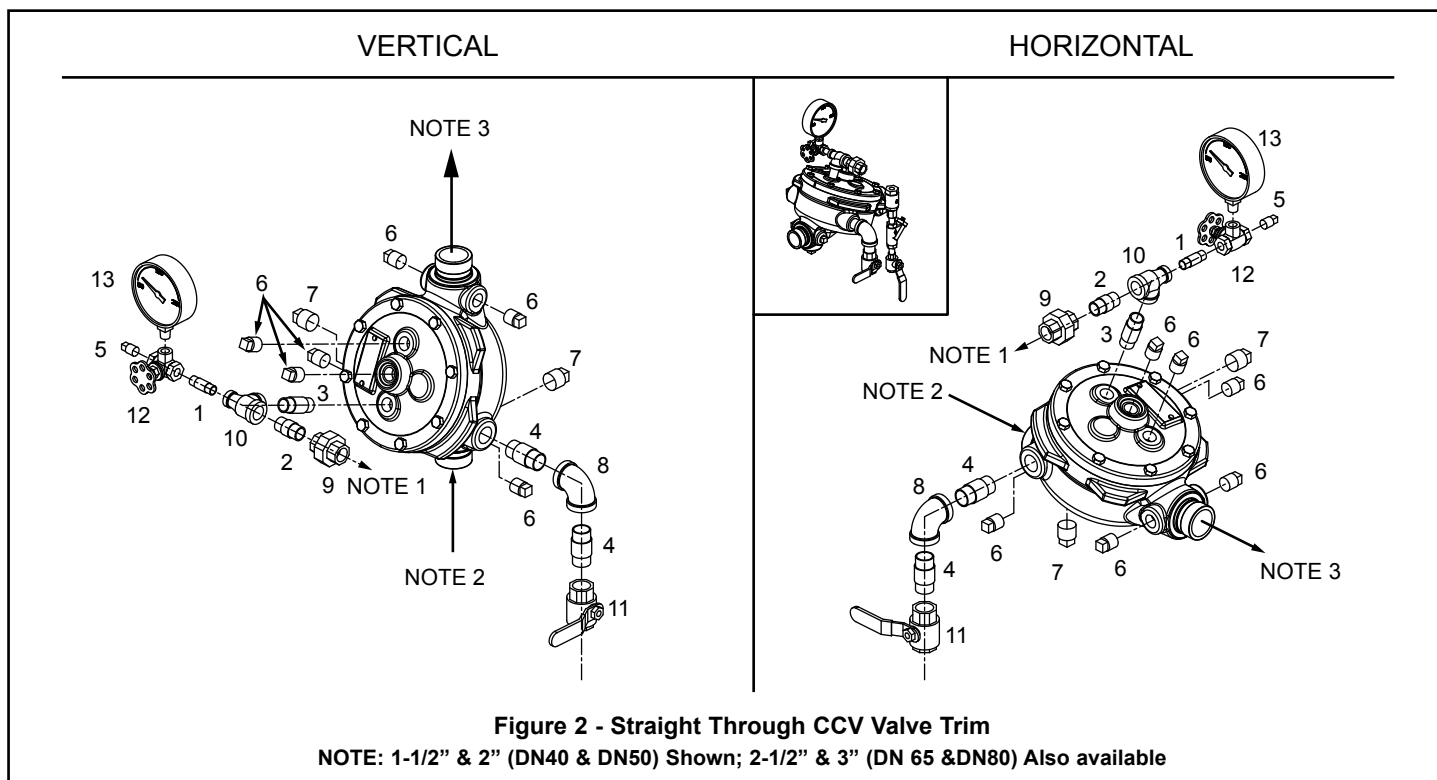

Table 1: CCV and Trim Components and Material Identification

REF.	SIZE (INCH)	DESCRIPTION	MATERIAL	
			G = Galvanized, B = Brass, ST = Stainless steel	
			On Galvanized Trim	On Brass Trim
1	1/4 X 1-1/2	NIPPLE	G	B
2	1/2 X 1-1/2	NIPPLE	G	B
3	1/2 X 2	NIPPLE	G	B
4	3/4 X 2	NIPPLE	B	B
5	1/4	PLUG	G	B
6	1/2	1/2 PLUG	ST	B
7	3/4	3/4 PLUG	B	B
8	3/4	3/4 ELBOW	B	B
9	1/2	1/2 UNION	G	B
10	1/2 X 1/4 X 1/2	TEE	G	B
11	3/4	SHUTOFF VALVE	-	-
12	1/4	SIDE OUTLET VALVE	-	-
13	1/4-	WATER GAUGE	-	-

Note 1: Field pipe to hydraulic release of system control valve or PORV as determined by system type.

Note 2: Foam concentrate inlet from bladder tank.

Note 3: To foam proportioner device.



TECHNICAL DATA

CONCENTRATE CONTROL VALVE APPLICATIONS, PRIMING CONNECTIONS, AND TRIMS

The Viking Corporation, 210 N Industrial Park Drive, Hastings MI 49058
 Telephone: 269-945-9501 Technical Services: 877-384-5464 Fax: 269-818-1680 Email: techsvcs@vikingcorp.com
 Visit the Viking website for the latest edition of this technical data page www.vikinggroupinc.com

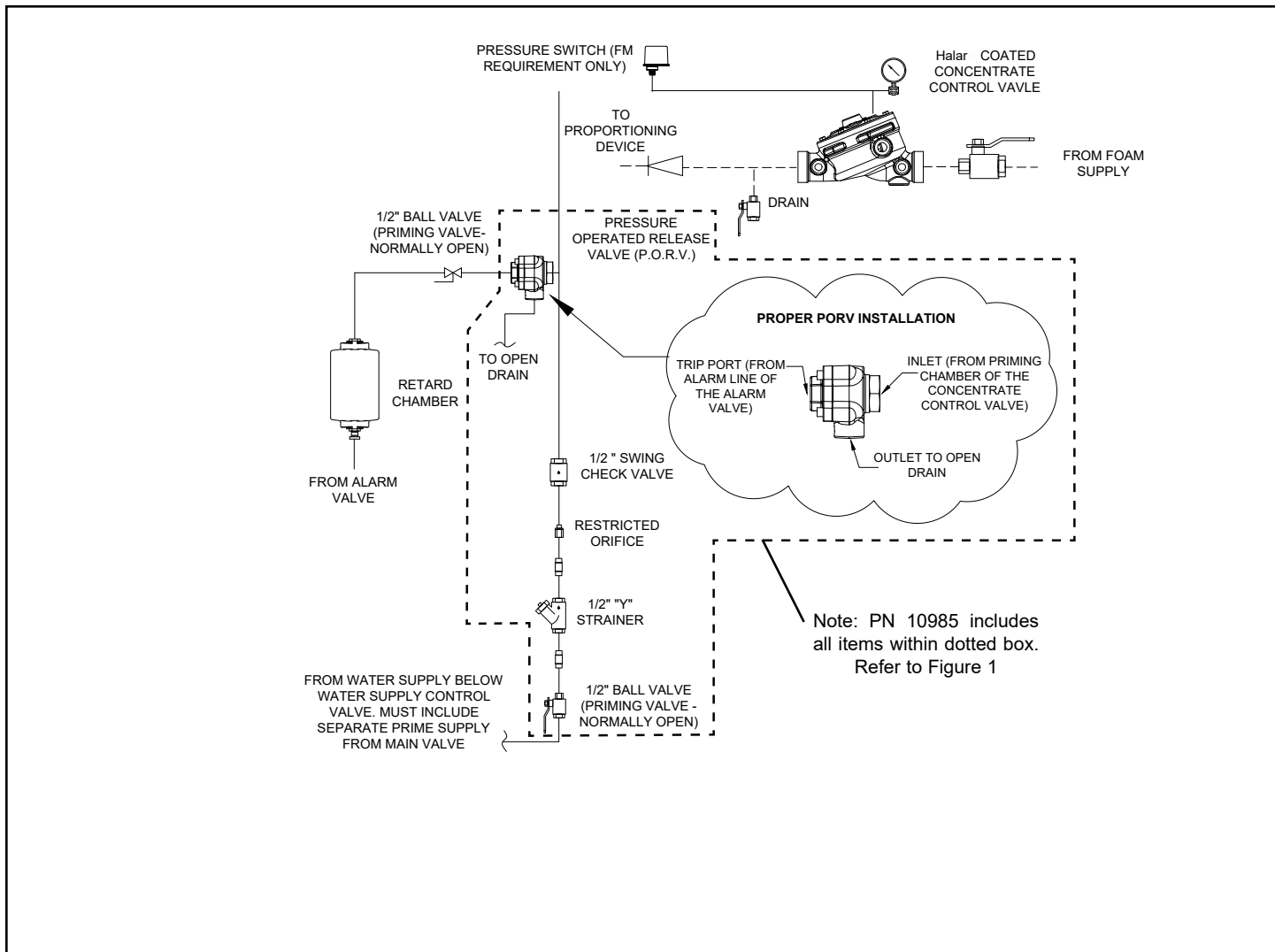

Figure 3 - Wet Pipe Foam Systems



TECHNICAL DATA

CONCENTRATE CONTROL VALVE APPLICATIONS, PRIMING CONNECTIONS, AND TRIMS

The Viking Corporation, 210 N Industrial Park Drive, Hastings MI 49058
 Telephone: 269-945-9501 Technical Services: 877-384-5464 Fax: 269-818-1680 Email: techsvcs@vikingcorp.com
 Visit the Viking website for the latest edition of this technical data page www.vikinggroupinc.com

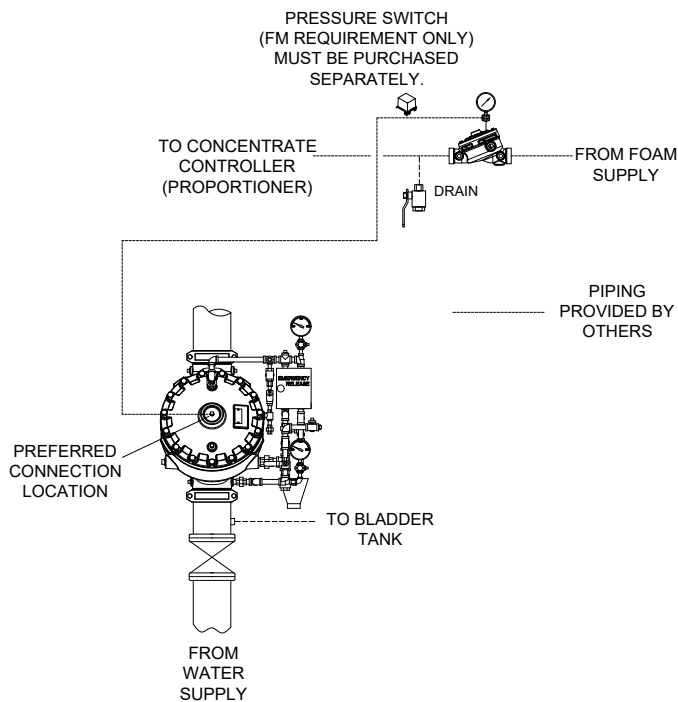

Figure 4 - Deluge and Preaction Systems



TECHNICAL DATA

SWING CHECK VALVE MODEL D-1 & G-1

The Viking Corporation, 210 N Industrial Park Drive, Hastings MI 49058

Telephone: 269-945-9501 Technical Services: 877-384-5464 Fax: 269-818-1680 Email: techsvcs@vikingcorp.com

1. DESCRIPTION

The Viking Swing Check Valve is a general purpose rubber-faced check valve approved for use in fire protection systems. The Swing Check Valve is manufactured with a ductile iron body, brass seat, and a rubber-faced clapper assembly, hinged to a removable access cover for easy inspection and maintenance.

The valve may be installed vertically or horizontally with access cover facing up. For availability of flanged-flanged and grooved-grooved options, refer to Table 1. Tapped openings (with plugs) and gauge connections are provided on both the inlet and outlet chambers of the valve.

FEATURES

- A. Ductile iron body for less weight and extra strength.
- B. Rated to 300 psi (20.7 bar) water working pressure.
- C. Rubber-faced clapper hinged to access cover for quick removal and easy servicing. All moving parts can be serviced without removing the valve from the installed position.
- D. With the cover/clapper assembly removed, the clapper rubber replacement requires removal of only one screw.
- E. Can be installed vertically or horizontally with access cover facing up.

2. LISTINGS AND APPROVALS

cULus Listed: Guide No. HMER

FM Approved: Single Check Valves

NYC Department of Buildings: MEA 89-92-E, Vol. XI

3. TECHNICAL DATA

Specifications:

Rated to 300 psi (20.7 bar) water working pressure.

Factory tested hydrostatically to 600 psi (41.4 bar).

Standard Flanged Connections: ANSI B16.42 Class 150 (mates with ANSI Class 125 and Class 150 flanges).

Standard Grooved Connections: ANSI/AWWA C606

Tapped Bosses: 2-1/2" (DN65), 3" (DN80) and 4" (DN100): Two 1/2" (15 mm) NPT
6" (DN150) and 8" (DN200): Two 3/4" (20 mm) NPT

Material Standards: Refer to Figure 1.

Ordering Information: Refer to Table 1 for part numbers and shipping weight.

Table 1

Size Valve Nominal	Inlet Type	Outlet Type	Friction Loss*	Shipping Weight	Part No.
2-1/2" (DN65)	Groove	Groove	6 ft.(1.8 m)	16 lbs. (7 kg)	05497C
3" (DN80)	Goove	Groove	10 ft. (3.1 m)	20 lbs. (9 kg)	08536
4" (DN100)	Flange	Flange	13 ft. (4.0 m)	47 lbs. (21 kg)	08538
4" (DN100)	Groove	Groove	13 ft. (4.0 m)	27 lbs. (12 kg)	08539
6" (DN150)	Flange	Flange	20 ft. (6.0 m)	75 lbs. (34 kg)	08542
6" (DN150)	Groove	Groove	20 ft. (6.0 m)	51 lbs. (23 kg)	08543
8" (DN200)	Flange	Flange	23 ft. (7.0 m)	135 lbs. (61 kg)	08546
8" (DN200)	Groove	Groove	23 ft. (7.0 m)	106 lbs. (48 kg)	08547

*Expressed in equivalent length of Schedule 40 pipe based on Hazen & Williams formula: C = 120.



WARNING: Cancer and Reproductive Harm-
www.P65Warnings.ca.gov

Viking Technical Data may be found on The Viking Corporation's Web site at <http://www.vikinggroupinc.com>. The Web site may include a more recent edition of this Technical Data Page.

Systems with water working pressures above 175 psi (12 bar) may require extra-heavy pattern fittings. Viking Swing Check Valve flanges are Ductile Iron ANSI B16.42, Class 150, with a maximum water working pressure of 300 psi (20.7 bar). ANSI B16.42, Class 150 flanges are NOT compatible with ANSI Class 250 or Class 300 flanges. To mate the Viking Swing Check Valve with ANSI Class 250 or Class 300 flanges, use the grooved-inlet/grooved-outlet style installed with listed grooved/ flanged adapters of the appropriate pressure rating. For piping with grooved connections, the grooved-inlet/grooved-outlet style Swing Check Valve may be installed with listed grooved couplings of the appropriate pressure rating.



TECHNICAL DATA

SWING CHECK VALVE MODEL D-1 & G-1

The Viking Corporation, 210 N Industrial Park Drive, Hastings MI 49058

Telephone: 269-945-9501 Technical Services: 877-384-5464 Fax: 269-818-1680 Email: techsvcs@vikingcorp.com

4. INSTALLATION

The Swing Check Valve must be installed in an area not subject to physical damage. When corrosive atmospheres and/or contaminated water supplies are present, it is the owner's responsibility to verify compatibility with the Swing Check Valve and associated equipment. Prior to installing the valve, thoroughly flush the water supply piping to verify that no foreign matter is present. The Swing Check Valve may be installed in the vertical position with direction of flow up, or in the horizontal position with the access cover up.

Systems with water working pressures above 175 psi (12 bar) may require extra-heavy pattern fittings. Viking Swing Check Valve flanges are Ductile Iron ANSI B16.42, Class 150, with a maximum water working pressure of 300 psi (20.7 bar). ANSI B16.42, Class 150 flanges are not compatible with ANSI Class 250 or Class 300 flanges. To mate the Viking Swing Check Valve with ANSI Class 250 or Class 300 flanges, use the grooved-inlet/grooved-outlet style installed with listed grooved/flanged adapters of the appropriate pressure rating. For piping with grooved connections, the grooved-inlet/grooved-outlet style Swing Check Valve may be installed with listed grooved couplings of the appropriate pressure rating.

5. OPERATION (Refer to Figure 1)

Flow through the Viking Swing Check Valve lifts the rubber-gasketed clapper (8, and 9) off the seat (12) to enter the sprinkler piping. When flow through the valve stops, the clapper (8) closes quickly. The rubber gasket (9) forms a tight seal against the brass water seat (12), trapping pressure above the clapper and preventing reverse flow from sprinkler piping.

Hydrostatic Test:

The Swing Check Valve is manufactured and listed for use at a maximum water working pressure of 300 psi (20.7 bar). The valve is factory tested at 600 psi (41.4 bar). Check Valves may be hydrostatically tested (in accordance with NFPA 13) at 350 psi (24.1 bar) and/or 50 psi (3.4 bar) above the normal water working pressure for limited periods of time (two hours) for the purpose of acceptance by the Authority Having Jurisdiction. If air testing is required, do not exceed 40 psi (2.8 bar) air pressure.

6. INSPECTIONS, TESTS AND MAINTENANCE

NOTICE: The owner is responsible for maintaining the fire-protection system and devices in proper operating condition.

The Viking Swing Check Valve must be kept free of foreign matter, freezing conditions (when used on wet systems), corrosive atmospheres, contaminated water supplies, and any condition that could impair its operation or damage the device.

It is imperative that the system be inspected and tested on a regular basis. The frequency of the inspections may vary due to contaminated water supplies, corrosive water supplies, and corrosive atmospheres. For minimum maintenance and inspection requirements, refer to NFPA 25. In addition, the Authority Having Jurisdiction may have additional maintenance, testing, and inspection requirements that must be followed.

WARNING: Any system maintenance which involves placing a control valve or detection system out of service may eliminate the fire-protection capabilities of that system. Prior to proceeding, notify all the Authority Having Jurisdiction. Consideration should be given to employment of a fire patrol in the affected areas.

6-A. Five-Year Internal Inspection

Internal inspection of Swing Check Valves is recommended every five years unless inspections and tests indicate more frequent inspections are required.

(Refer to Figure 1)

1. Notify the Authority Having Jurisdiction, remote station alarm monitors, and those in the area affected that the system will be taken out of service. Consideration should be given to employment of a fire patrol in the affected areas.
2. Close the water supply main control valve, placing the system out of service.
3. Open the main drain. If necessary, open the system test valve to vent and completely drain the system.
4. Use the appropriate wrench to loosen and remove the cover screws (14), and remove the cover/clapper assembly (2-11).
5. Inspect the water seat (12). Wipe away all contaminants, dirt, and mineral deposits. DO NOT use solvents or abrasives.
6. Inspect the cover/clapper assembly (2-11) and the cover gasket (13). Test the hinged clapper (8) for freedom of movement. Renew or replace damaged or worn parts as required.

CAUTION: Never apply any lubricant to seats, gaskets, or any internal operating parts of the valve. Petroleum-based grease or oil will damage rubber components and may prevent proper operation.

7. When Internal inspection of the Check Valve is complete, perform step 6 of paragraph 11. VALVE MAINTENANCE to re-install the cover/clapper assembly (2-11).



TECHNICAL DATA

SWING CHECK VALVE MODEL D-1 & G-1

The Viking Corporation, 210 N Industrial Park Drive, Hastings MI 49058

Telephone: 269-945-9501 Technical Services: 877-384-5464 Fax: 269-818-1680 Email: techsvcs@vikingcorp.com

6-B. Valve Maintenance

(Refer to Figure 1)

1. Perform steps 1 through 5 of paragraph 6.A - FIVE-YEAR INTERNAL INSPECTION.
2. To remove clapper rubber (9):
 - a. Use the appropriate wrenches to loosen and remove the button-head socket screw (11), hex nut (6), sealing washer (7), and rubber retainer (10).
 - b. Remove the clapper rubber (9) for inspection. If the clapper rubber shows signs of wear, such as cracking, cuts, or excessively deep grooves where the rubber contacts the water seat, replace the rubber.
3. To re-install clapper rubber (9):
 - a. Place the clapper rubber (9) over the center hub of the rubber retainer (10).
 - b. Position the retainer (10) (with rubber in place) against the clapper (8) as shown in Figure 1.
 - c. Replace and tighten the button-head socket screw (11), sealing washer (7), and hex nut (6). The sealing washer (7) and hex nut (6) must be located on the top side of the clapper as shown in Figure 1. Do not over-tighten.
4. To remove clapper (8), and/or hinge pin (4):
 - a. Remove the hinge pin retaining rings (5) to free the hinge pin (4) for removal. After the hinge pin (4) is removed, the clapper (8) can be removed.
5. To re-install clapper (8), and/or hinge pin (4):
 - a. Verify that the clapper rubber (9) is in good condition and that it is properly installed.
 - b. Position the clapper (8) with the elongated hinge holes aligned between the holes of the hinge bracket welded inside the cover (2). The system (top) side of the clapper (8) must face the direction indicated by the flow arrow stamped inside the cover (2).
 - c. Insert the hinge pin (4) through the holes at one end of the hinge assembly. Continue to push the hinge pin (4) through the holes at the remaining end of the hinge assembly.
 - d. Re-install the hinge pin retaining rings (5).
6. To re-install cover/clapper assembly (2-11):
 - a. Verify that cover gasket (13) is in position and in good condition.
 - b. Slide the cover/clapper assembly (2-11) into the Swing Check Valve so that the clapper rubber (9) contacts the water seat (12).
 - c. Replace the cover screws (14). Use the appropriate wrench to cross-tighten all screws to the torque value shown in Table 2 for the valve used. DO NOT over-tighten.

7. AVAILABILITY

The Viking Swing Check Valve is available through a network of domestic and international distributors. See the Viking Corp. Web site for closest distributor or contact The Viking Corporation.

8. GUARANTEES

For details of warranty, refer to Viking's current list price schedule or contact The Viking Corporation directly.

Table 2: Torque Values for Viking Swing Check Valve Cover Screws

Valve Size	Screw Size	Torque Values
2-1/2" (DN65)	3/8"-16 HHC	19 ft-lbs 2.63 kg-m
3" (DN80)	3/8"-16 HHC	19 ft-lbs 2.63 kg-m
4" (DN100)	3/8"-16 HHC	19 ft-lbs 2.63 kg-m
6" (DN150)	1/2"-13 HHC	45 ft-lbs 6.23 kg-m
8" (DN200)	5/8"-11 HHC	93 ft-lbs 12.9 kg-m



TECHNICAL DATA

SWING CHECK VALVE MODEL D-1 & G-1

The Viking Corporation, 210 N Industrial Park Drive, Hastings MI 49058

Telephone: 269-945-9501 Technical Services: 877-384-5464 Fax: 269-818-1680 Email: techsvcs@vikingcorp.com

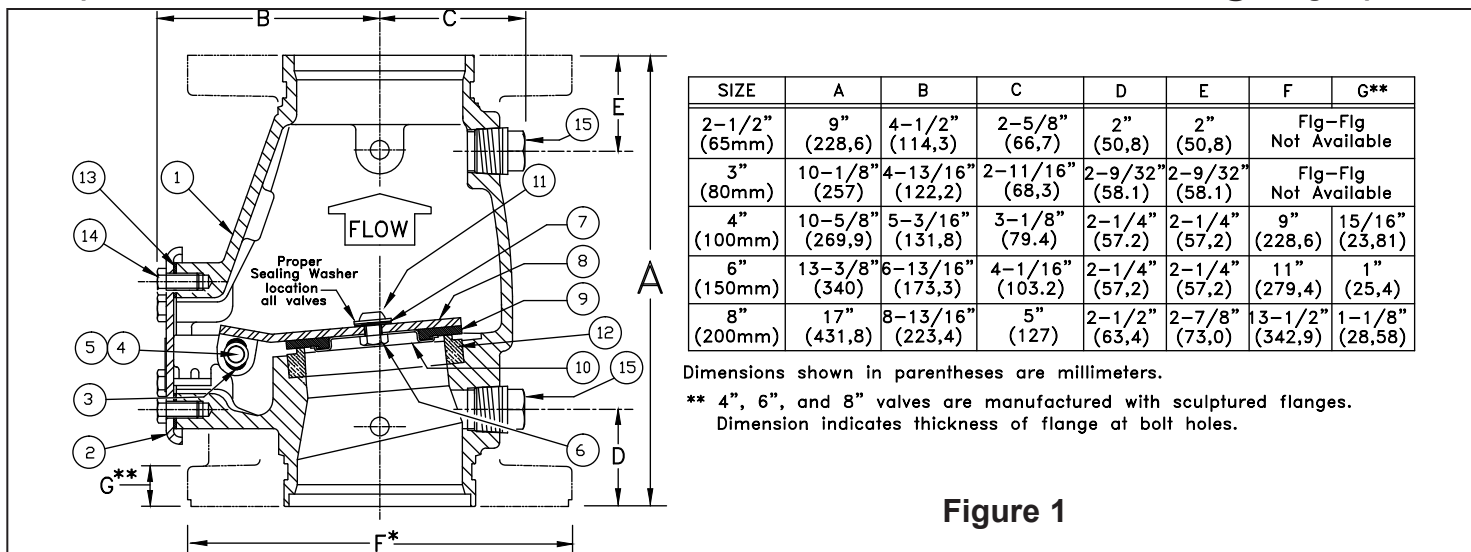

Figure 1

ITEM NO.	PART NUMBER					DESCRIPTION	MATERIAL	NO. REQ'D						
	D-1	G-1	G-1	G-1	G-1									
	2-1/2" (DN65)	3" (DN80)	4" (DN100)	6" (DN150)	8" (DN200)			2-1/2"	3"	4"	6"	8"		
1	--	--	--	--	--	Body	Ductile Iron, ASTM A536 (65-45-12)	1	1	1	1	1		
2	--	--	--	--	--	Cover Assembly, 300 PSI WWP	E-Coated HSLA Steel, A715 and Stainless Steel, UNS-S30400	1	1	1	1	1		
3	07576	07576	07576	07576	None	Bushing	Lubricomp 189 Ryton	2	2	2	2	0		
4	05355A	05355A	04900A	04991A	05334A	Clapper Hinge Pin	Stainless Steel, UNS-S30400	1	1	1	1	1		
5	05445A	05445A	05445A	05445A	05369A	Hinge Pin Retaining Ring	Stainless Steel, UNS-S15700	2	2	2	2	2		
6	01755A					Clapper Hex Jam Nut #10-24 UNC	Stainless Steel, UNS-S30400	1	0	0	0	0		
		08159	08159			Clapper Hex Jam Nut 3/8"-24 UNF	Stainless Steel, UNS-S30400	0	1	1	0	0		
				08144	08144	Clapper Hex Jam Nut 1/2"-20 UNC	Stainless Steel, UNS-S30400	0	0	0	1	1		
7	06595A	08158	08158	08143	08143	Sealing Washer	EPDM and Stainless Steel	1	1	1	1	1		
8	*	*	*	*	*	Clapper	Teflon® Coated HR Steel UNS-G10180	1	1	1	1	1		
9	*	*	*	*	*	Clapper Rubber	EPDM, ASTM D2000	1	1	1	1	1		
10	*	*	*	*	*	Clapper Rubber Retainer	Stainless Steel, UNS-S30400	1	1	1	1	1		
11	06595A					H.H.C. Screw #10-24 UNC x 1/2" (12.7 mm) lg.	Stainless Steel, UNS-S30400	1	0	0	0	0		
		10194	10194			Screw, Button Head, Socket, 3/8" - 24 UNF x 1/2"	Stainless Steel, UNS-S30400	0	1	1	0	0		
				10308		Screw, Button Head, Socket, 1/2" - 20 UNF x 3/4" (19.1 mm) lg.	Stainless Steel, UNS-S30400	0	0	0	1	1		
					10686	Screw, Button Head, Socket, 1/2" - 20 UNF x 7/8"	Stainless Steel, UNS-S30400	0	0	0	0	1		
12	--	--	--	--	--	Seat	Brass, UNS-C84400	1	1	1	1	1		
13	05354B	05354B	04649B	04992B	05339C	Cover Gasket	EPDM, ASTM D2000	1	1	1	1	1		
14	01517A	01517A	01517A			H.H.C. Screw 3/8"-16 UNC x 3/4" (19,1 mm) lg.	Steel, Zinc Plated	4	4	6	0	0		
				04993A		H.H.C. Screw 1/2"-13 UNC x 7/8" (22,2 mm) lg.	Steel, Zinc Plated	0	0	0	6	0		
					01922A	H.H.C. Screw 5/8"-11 UNC x 1-1/4" (31,8 mm) lg.	Steel, Zinc Plated	0	0	0	0	6		
15	--	--	--			1/2" (15 mm) NPT Pipe Plug	Steel	2	2	2	0	0		
				--	--	3/4" (20 mm) NPT Pipe Plug	Steel	0	0	0	2	2		

-- Indicates replacement part is not available

* Indicates replacement part only available in a Sub-Assembly listed below.

Sub-Assemblies

3, 6-11	05499B	08518	08519	08520	08521	Clapper Assembly
9, 10	--	14864	14865	14866	--	Replacement Clapper Rubber Kit*

*Clapper rubbers are different on 3", 4", & 6" G-1 valve than original manufacture. If clapper rubber requires replacement, order replacement rubber kit.

Bronze Ball Valves

Three-Piece Body • Full Port • 316SS Trim • Blowout-Proof Stem • Vented Ball



600 PSI/41.4 bar non-shock cold working pressure
150 PSI/10.3 bar saturated steam*

CONFORMS TO MSS SP-110

MATERIAL LIST

PART	SPECIFICATION
1. Handle Nut	Stainless Steel 300 Series
2. Handle	Zinc Plated Steel Clear Chromate Plastisol Coated
3. Threaded Pack Gland	Brass ASTM B 16 Alloy C36000
4. Stem	Stainless Steel ASTM A 276 Type 316
5. Body	Bronze ASTM B 584 Alloy C84400
6. Packing	PTFE
7. Body End (2)	Cast Bronze ASTM B 584 Alloy C84400
8. O-Ring Seal (2)	Fluorocarbon Rubber
9. Seat Ring (2)	PTFE
10. Ball (Vented)	Stainless Steel ASTM A 276 Type 316 or ASTM A 351 Type CF8M
11. Thrust Washer	Reinforced PTFE
12. Body Bolts	Zinc Dichromate Plated Steel ASTM A 449 Grade 5
13. Body Nuts	Zinc Dichromate Plated Steel ASTM A 449 Grade 5

Note: valves are static grounded by a grounding washer. (not shown)



T-595-Y-66
Threaded



S-595-Y-66
Solder

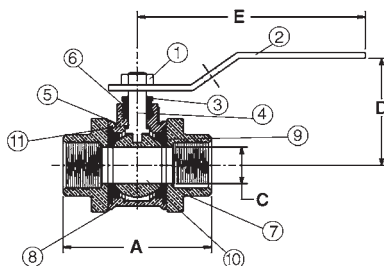

T-595-Y-66
NPT x NPT

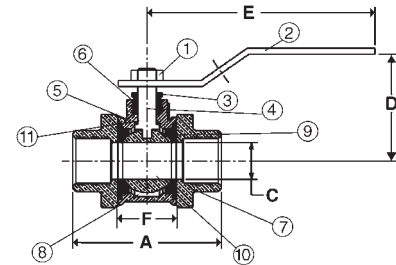
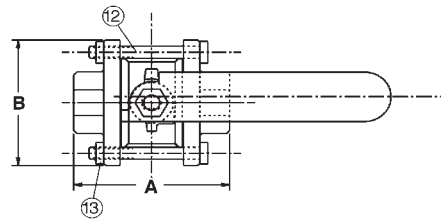

S-595-Y-66
C x C

DIMENSIONS—WEIGHTS—QUANTITIES

Size	T-595-Y-66		S-595-Y-66		Dimensions					S-595-Y-66				Master Ctn. Qty.						
	A	A	B	C	D	E	F	T-595-Y-66	S-595-Y-66	Lbs.	Kg.	Lbs.	Kg.							
1/4	8	2.50	64	1.69	43	1.81	46	.38	10	1.69	43	3.91	99	.875	29	1.03	.47	.89	.40	50
3/8	10	2.50	64	1.81	46	1.81	46	.38	10	1.69	43	3.91	99	.875	29	.98	.44	.89	.40	50
1/2	15	2.50	64	2.06	52	1.81	46	.50	13	1.69	43	3.91	99	.875	29	1.03	.47	.89	.40	50
3/4	20	3.00	76	2.94	75	1.94	49	.75	19	2.00	51	4.66	118	1.190	37	1.70	.77	1.59	.72	30
1	25	3.69	94	3.66	93	2.50	64	1.00	25	2.25	57	4.66	118	1.563	47	2.82	1.28	2.55	1.15	20
1 1/4	32	4.09	104	3.91	99	2.69	68	1.25	32	2.75	70	6.69	170	1.750	50	3.96	1.80	3.61	1.64	10
1 1/2	40	4.56	116	4.60	117	3.00	76	1.50	38	2.97	75	6.69	170	2.125	60	5.68	2.57	5.31	2.41	10
2	50	6.16	156	5.78	147	4.00	102	2.00	51	3.63	92	6.69	170	2.640	78	11.40	5.17	10.60	4.81	4
2 1/2	65	6.84	174	6.94	176	5.00	127	2.50	64	4.09	104	8.00	203	3.463	102	21.07	9.56	19.30	8.75	2

*For detailed operating pressure, refer to pressure temperature chart on page 41.



WARNING: This product can expose you to chemicals including lead, which is known to the State of California to cause cancer and birth defects or other reproductive harm. For more information go to www.P65Warnings.ca.gov.

**LEAD FREE*
OPTION
AVAILABLE**

**OXYGEN
SERVICE
OPTION
AVAILABLE**

*Weighted average lead content ≤ 0.25%

Visit our website for the most current information.



KENNEDY VALVE



UL/FM BUTTERFLY VALVES



Designed for the Fire Protection Industry

Sizes: 2-1/2", 3", 4", 6", 8"

300 PSI Rated

Double Seal Design for Bubble Tight Shut Off

Outdoor Rated

CA. State Fire Marshall Accepted

Lightweight

Fusion Bonded Coated Body

Low Torque Operation

Easy to Read Flag Type Indicator

KENNEDY VALVE

Division of McWane, Inc.

1021 East Water St., Elmira, NY 14901 (607) 734-2211

Grooved End Butterfly Valves 2 1/2" to 8" Figure G300/G300C & 01G 300 psi with Supervisory Tamper Switch

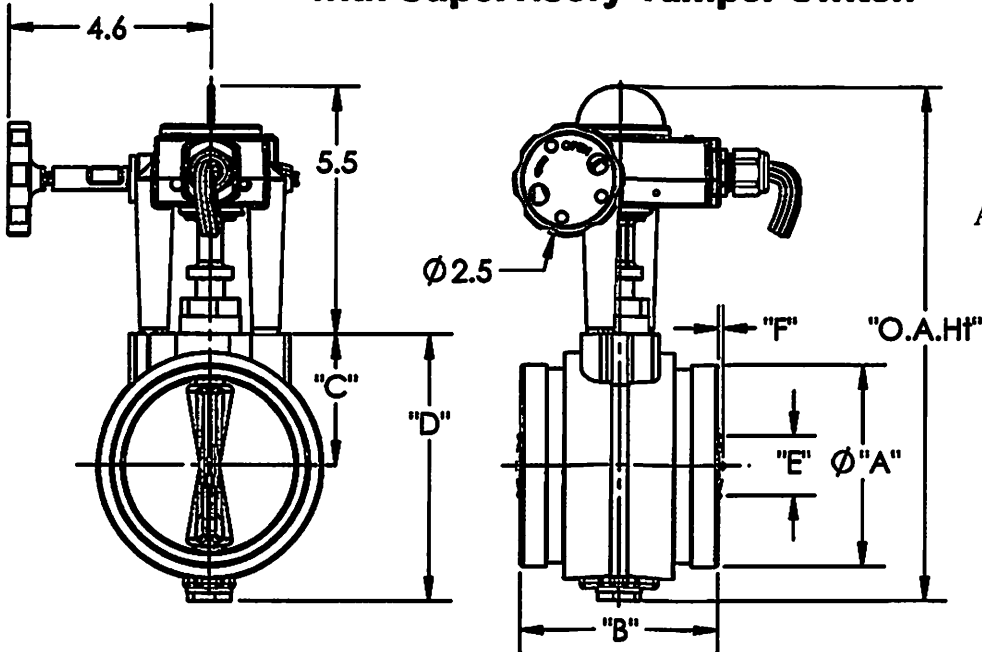

Sizes 2 1/2" - 6"
G300/G300C
Outdoor Rated UL/FM
Available Normally Open
and Normally Closed

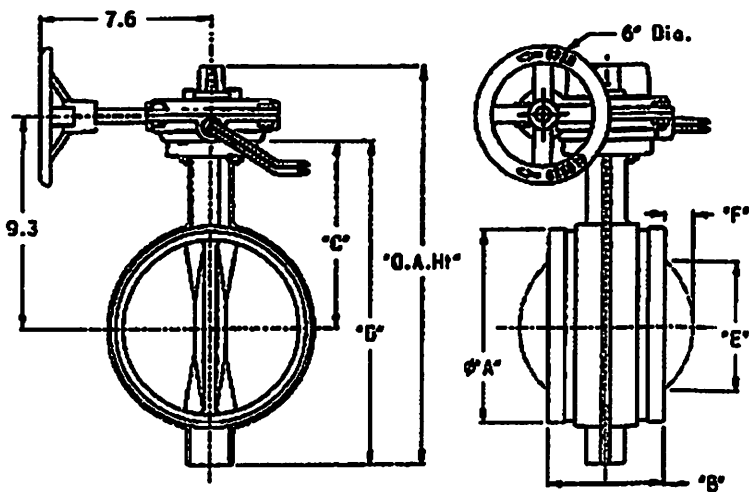

Size 8" Only
OIG
Outdoor Rated UL
Available Normally Open
and Normally Closed

1. UPPER AND LOWER SHAFTS 410SS/414SS					
2. BODY COATING: EPOXY					
3. DISC ENCAPSULATION MTL: EPDM					
	G300				01G
SIZE	2 1/2"	3"	4"	6"	8"
A	2.85	3.4	4.4	6.6	8.6
B	3.8	3.8	4.5	5.8	5.2
C	2.2	2.4	2.9	4.0	8.2
D	4.3	4.8	5.9	8.1	14.3
E	N/A	N/A	N/A	1.7	5.9
F	N/A	N/A	N/A	1	1.3
O.A. HI	10.0	10.4	11.6	13.8	17.6
WT. #	8.8	10.1	13.5	24.6	44

Note: "E will be MINIMUM allowed pipe I.D.
Exercise care handling and installing



KENNEDY VALVE

Division of McWane, Inc.



1021 East Water St., Elmira, NY 14901 (607) 734-2211

Grooved End Butterfly Valves 2 1/2" to 8"

Figure G300E/G300EC & 02G 300 psi with Supervisory Tamper Switch

- Extended Length Valves Equipped with Four 3/4" NPT Ports
- 4"-8" Sizes Approved for Cross Connection
- NSF61 Certified

Connection Control and Hydraulic Research at the University of Southern California

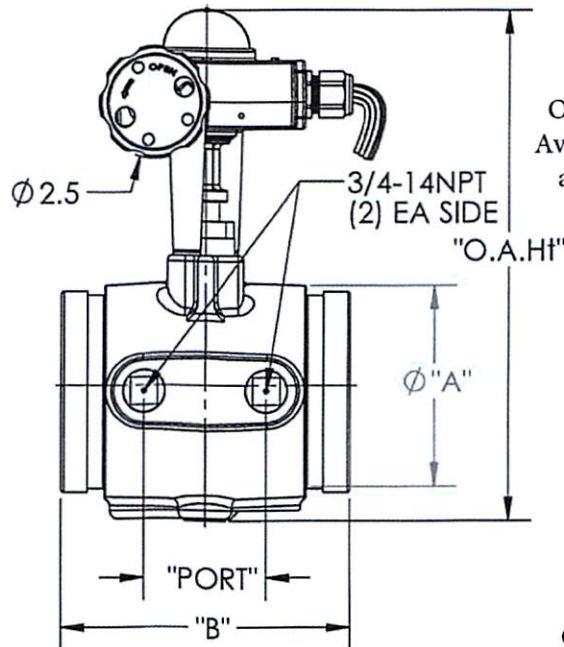
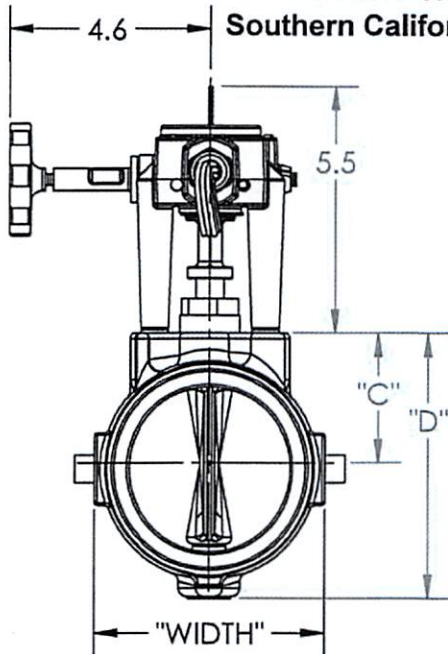

Sizes 2 1/2" - 6"
G300E / G300EC
Outdoor Rated UL/FM
Available Normally Open
and Normally Closed

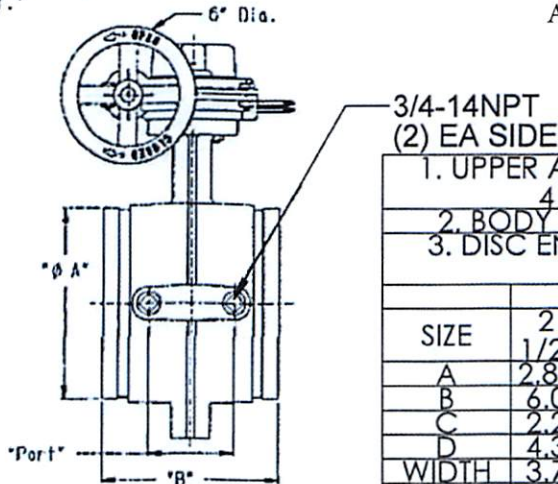
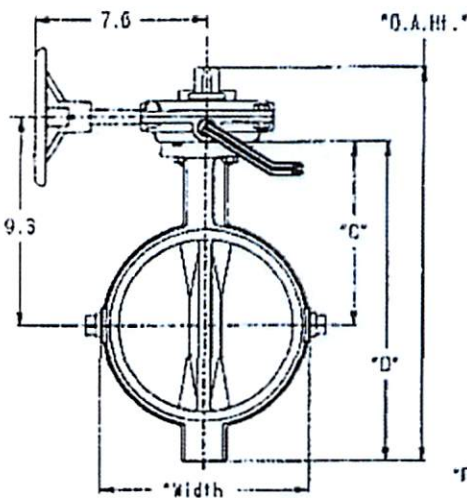

8" Only
02G
Outdoor Rated UL
Available Normally Open
and Normally Closed

	1. UPPER AND LOWER SHAFTS 410SS/416SS				
	2. BODY COATING: EPOXY				
	3. DISC ENAPSULATION MTL: EPDM				
	G300E				02G
SIZE	2 1/2"	3"	4"	6"	8"
A	2.85	3.47	4.47	6.61	8.6
B	6.0	6.3	6.6	6.9	7.9
C	2.2	2.4	2.9	4.0	8.2
D	4.3	4.8	5.9	8.1	14.3
WIDTH	3.7	4.2	5.2	7.4	9.3
PORT	2.3	2.6	2.8	3.1	2.3
O.A. HT	10.0	10.4	11.6	13.8	17.6
WT. #	12.5	14.5	18	28	55

Note: Disc does not protrude past the "B" dimension of the body on any size in the open position. Exercise care handling and during installation



KENNEDY VALVE
 Division of McWane, Inc.



1021 East Water St., Elmira, NY 14901 (607) 734-2211

Wafer Butterfly Valves 2 1/2" to 8"
Figure W300/W300C, W300I, & 01W 300 psi
with Supervisory Tamper Switch

Valve Selection for ISO PN16 Flange	
Flange Size	KV Model
65MM	2 1/2" W300
80MM	3" W300I
100MM	4" W300I
150MM	6" W300

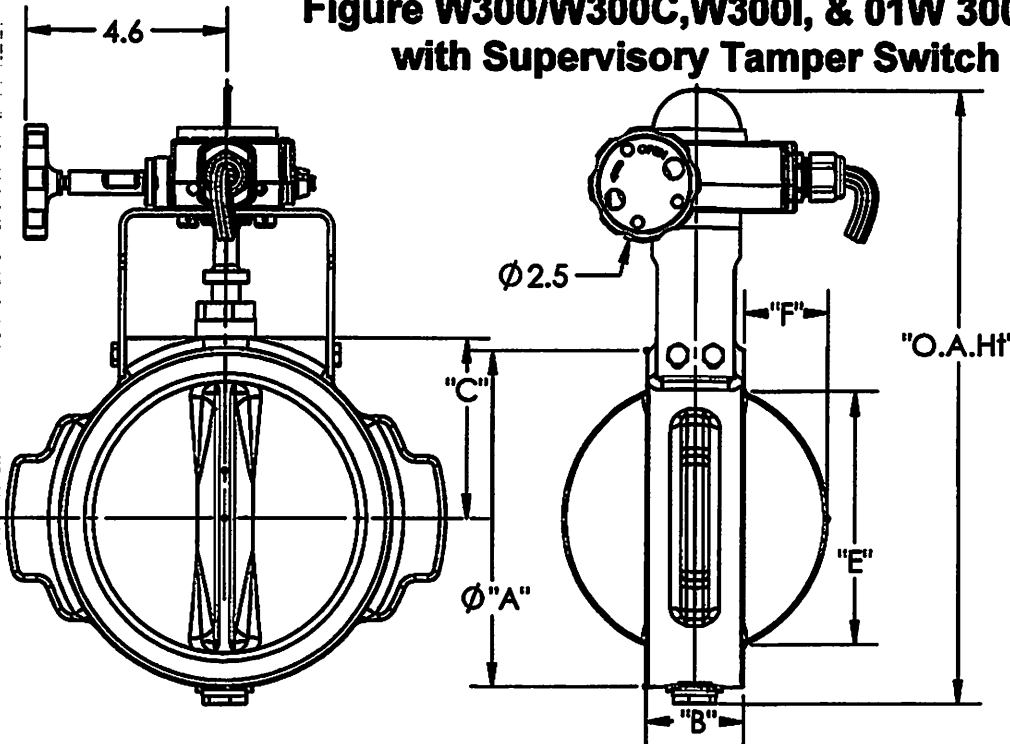

Sizes 2 1/2" - 6"
 W300/W300C/W300I
 Outdoor Rated UL /FM
 Available Normally Open and
 Normally Closed

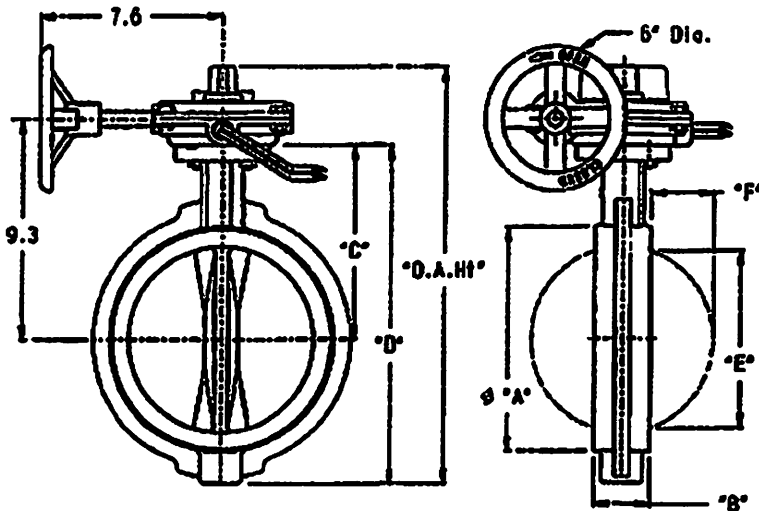

8" Size Only
 02G
 Outdoor Rated UL Available
 Normally Open and
 Normally Closed

WAFFER BOLTING					
SIZE	2-1/2"	3"	4"	6"	8"
Number of Studs	4	4	8	8	8
Stud Size (Inch)	5/8	5/8	5/8	3/4	3/4
Stud Length Min (Inch)	5.5	5.5	6.5	7	7.5
Recommended Min Torque (Ft Lbs)	30	30	30	40	50

SIZE	1. UPPER AND LOWER SHAFTS 410SS/416SS				
	2. BODY COATING: EPOXY				
	3. DISC ENAPSULATION MIL: FPDM				
	W300, W300I				01W
	2 1/2"	3"	4"	6"	8"
A	4.2	4.4	5.3	7.5	9.5
B	1.8	1.8	2.0	2.2	2.4
C	2.2	2.4	2.9	4.0	8.2
D	4.3	4.8	5.9	8.1	14.3
E	1.7	4.2	3.3	5.6	9.3
F	4	6	9	1.9	2.7
O.A. HT	10.0	10.4	11.6	13.8	17.6
WT.#	10.5	11.1	13.8	20.5	44

Dimensions B, D, and E are referenced in Installation Instructions
 "E" is MINIMUM allowed Pipe I.D.
 Exercise care handling and during Installation

KENNEDY VALVE

Division of McWane, Inc.

1021 East Water St. Elmira, NY 14901

UL/FM BUTTERFLY VALVES

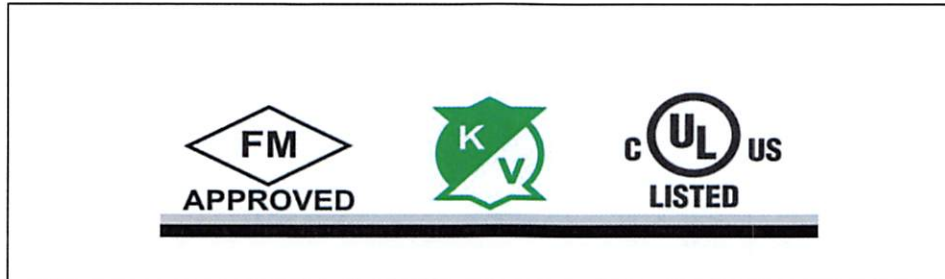

INSTALLATIONS INSTRUCTIONS FOR INDOOR & OUTDOOR USE

CAUTION

PRIOR TO INSTALLATION OF SUPERVISORY SWITCHES IN FIRE PROTECTION SYSTEMS, REFER TO THE FOLLOWING STANDARDS:

- 1) NFPA 13: STANDARDS FOR THE INSTALLATION OF SPRINKLER SYSTEMS
- 2) NFPA 25: INSPECTION, TESTING, MAINTENANCE OF WATER BASED FIRE PROTECTION SYSTEMS
- 3) NFPA 70: NATIONAL ELECTRICAL CODE
- 4) NFPA 72 NATIONAL FIRE ALARM CODE

WARNING

- 1) REMOVE CORD GRIP FROM GEARBOX BEFORE INSTALLING CONDUIT
- 2) METALLIC CONDUIT REQUIRED BY NEC FOR PROPER GROUNDING
- 3) CONDUIT JOINTED MUST BE SEALED WITH CONDUIT SEALANT
- 4) INSTALL SWITCH IN ACCORDANCE WITH NATIONAL ELECTRICAL CODE AND/OR LOCAL ORDINANCES
- 5) ASSURE ALL DEVICES ARE PROPERLY GROUNDED

G300, G300E, 01G, 01GC
G300C, G300EC, 02G, 02GC
W300, W300C, 01W, 01WC

INSTALLATION INSTRUCTIONS
FOR INDOOR & OUTDOOR USE

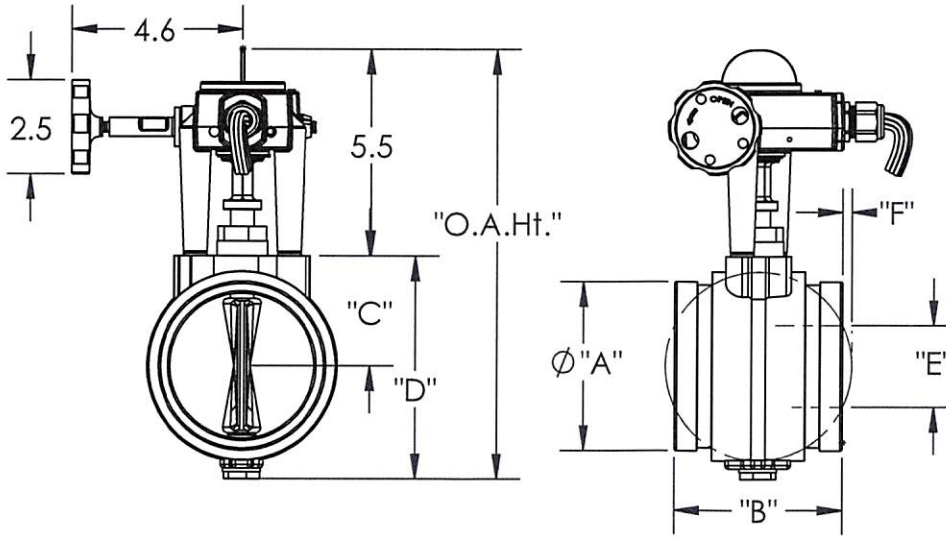

G300
6" SHOWN

THIS STYLE AVAILABLE ON
2.5", 3", 4", 6" & 8" SIZES

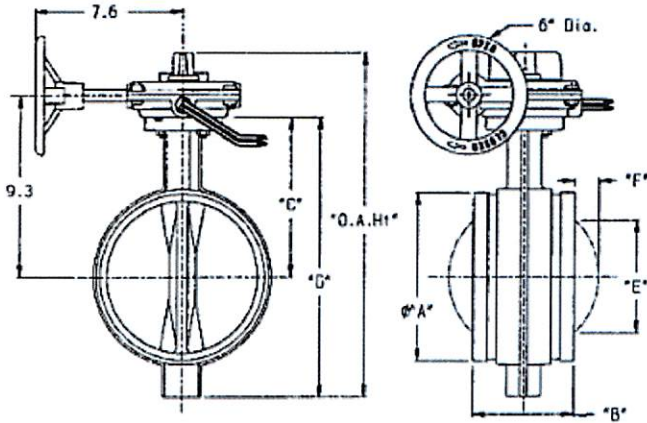

01G
8" SHOWN

NOTE:
INTEGRAL GEARBOX
STYLE APPROVED 2015

FIRE PROTECTION PRODUCT IS NOT
NSF CERTIFIED. FOR ACQUIRING NSF61
CERTIFICATION OR USC LISTINGS,
CONTACT THE KENNEDY VALVE SALES
DEPART.

1. UPPER AND LOWER SHAFTS 410SS/416SS
2. BODY COATING: EPOXY
3. DISC ENAPSULATION MTL: EPDM

SIZE	G300					W300					01W
	2.5"	3"	4"	6"	8"	2.5"	3"	4"	6"	8"	8"
A	2.85	3.47	4.47	6.61	8.6	4.2	4.4	5.3	7.5	9.5	
B	3.8	3.8	4.5	5.8	5.2	1.8	1.8	2.0	2.2	2.4	
C	2.2	2.4	2.9	4.0	8.2	2.2	2.4	2.9	4.0	8.2	
D	4.3	4.8	5.9	8.1	14.3	4.3	4.8	5.9	8.1	14.3	
E	N/A	N/A	N/A	1.7	5.9	1.7	4.2	3.3	5.6	9.3	
F	N/A	N/A	N/A	.1	1.3	.4	.6	.9	1.9	2.7	
O.A. HEIGHT	10.0	10.4	11.6	13.8	17.6	10.0	10.4	11.6	13.8	17.6	
WT. (POUNDS)	8.8	10.1	13.5	24.6	44	10.5	11.1	13.8	20.5	44	

GROOVED END CONNECTIONS: FOR USE WITH STEEL GROOVED END PIPE (IPS)
MATING PIPE AND COUPLINGS TO CONFORM TO IPS STEEL PIPE DIMENSIONS
FOR OUTSIDE GROOVE AND GASKET SEATING DIMENSIONS.
SEE DIAGRAM DIM "E" FOR MINIMUM INSIDE DIAMETER OF PIPE.

PIPE CONNECTION SPECIFICATIONS-ALL VALVES RATED 300 PSI

SUPERCEDES		KENNEDY VALVE DIVISION OF MCWANE, INC. TECHNICAL SERVICE MANUAL	ISSUED		DRAWING	
DATE	PAGE		BY	DATE	32271-04	
N/A	N/A		PJD	2/16/21	(PAGE 1/2)	

BUTTERFLY VALVES

Models: G300/G300E/G300C/G300EC/W300/W300E/W300C/W300EC/W30001/01G/02G/01W

SUPPLEMENTARY INSTALLATION INSTRUCTIONS

Information shown here is intended to supplement, not to replace, instructions that are shipped with each valve. Dimensional information regarding minimum pipe I.D. and disc protrusion are shown on dimensional page for particular valve. Exercise care handling and during assembly.

Grooved Body

For use with IPS grooved end.

see valve dimensional information for min. pipe I.D. (dimension E)

Valves shall be installed by person(s) certified to install grooved end fittings in a fire protection system by authority having jurisdiction:

*Follow grooved coupling manufacturers latest published directions.

Wafer Body

For installation between two ANSI B16.1, 125lb. flanges see valve dimensional information for min. pipe I.D. (dimension E)

1. Two flanged mating pieces should be placed at a distance apart that is slightly more than the thickness of the body (dimension B on wafer table)
2. A minimum of 2 studs shall be placed through adjacent flange holes so that the lower trunnion of the valve can fit between them. Normally this is the bottom 2 holes if the valves will be vertical with open/closed indicator on top
3. Place the valve between the flanges taking care to not disturb the body gaskets.
4. Place remaining studs around the valve and tighten using an alternating pattern until desired torque is reached.
5. O-ring gaskets are shipped with valve to help facilitate installation against ANSI class flanges. When mating to grooved flange adapters the o-ring gaskets can be discarded.

Switch Wiring

1. Valve has internal switches that operate from the OPEN position. Normally Closed valves are an option(W300C/G300C/G300EC), and operate from CLOSED position
2. One switch has dual leads that is for connection to the SUPERVISORY circuit of an alarm panel. The other switch has single leads and is intended to be connected to AUXILIARY equipment
3. Tuck unused leads into junction box (not provided)
4. Always comply with national codes, local codes and NFPA 13/71 and 72

G300,G300E,W300E WIRING 2 1/2" - 8" VALVE NORMALLY OPEN (G300,G300E,W300,01G,02G,01W) OR VALVE NORMALLY CLOSED (G300C,W300C,G300EC,01GC,02GC,01WC)

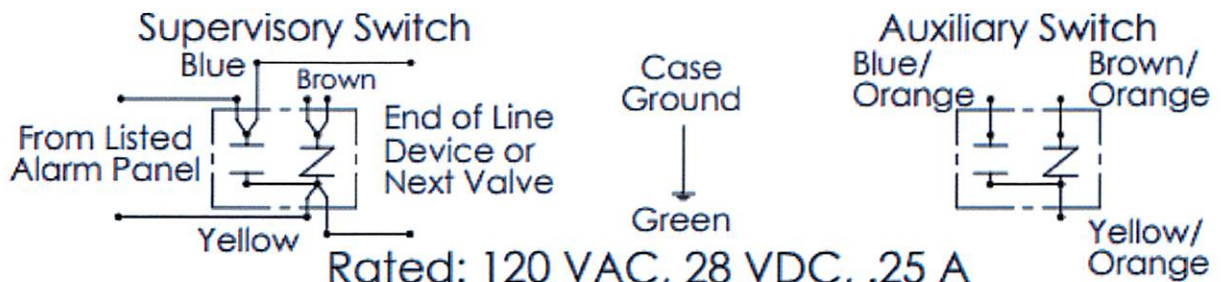

Wiring Notes: Connection to power limited circuitry is required.
Auxiliary switch connections are not intended for electrical supervision.
Switches are checked at factory, check continuity with valve fully open (or closed for normally closed valves), switches activates within 2 turns of handwheel from open.



Kennedy Valve
A Division of McWane Inc
www.kennedyvalve.com

2020

1021 E Water St. Elmira, NY 14901

P.O. Box 981

Phone (607) 734-2211 Fax: 1-800-952-4771

Angle Hose Valves Fig. 07-000

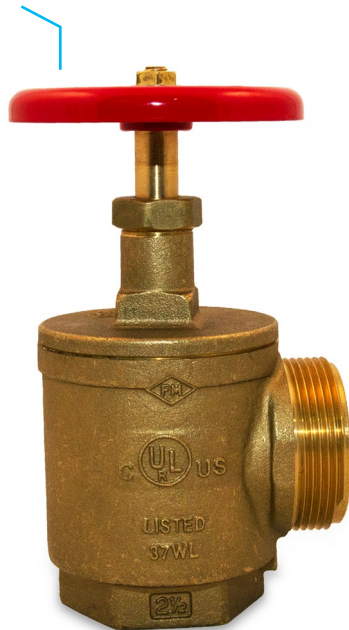

Description

Angle hose valves feature all brass* construction with forged or cast bodies for rigidity and light weight. Typical uses are in rack assemblies or any other application which requires a listed fire hose valve. Available in rough brass or polished chrome finish with a red hand wheel. UL, ULc Listed, FM Approved. Rated 300psi.

Installation

Install in accordance with customary installation practices. Use an approved thread sealant such as PipeFit® Thread Sealing Paste with PTFE on the male threads to which the valve is being installed.

DO NOT OVER TIGHTEN. Over tightening of the valve during installation to the male pipe threads may crack or deform the valve body. Only use tools suitable for the installation of this product. Do not use pipe wrench extenders to increase leverage on pipe wrenches. This may result in valve damage as well as personal injury.

The information contained herein is produced in good faith and is believed to be reliable but is provided for guidance and information purposes only. FPPI and its agents cannot assume liability or responsibility for results obtained in the use or misuse of its product by persons whose methods and qualifications are outside and beyond our control. It is the user's responsibility to determine the suitability of, methods of use, preparation prior to use, and appropriate installation for all products purchased from FPPI. It is the user's sole responsibility to observe and adapt such precautions as may be advisable or necessary for the protection of personnel and property in the handling and use of any of our products.

Specifications

Nomenclature and Material:

Material:

Cast or Forged Brass* Body

Finish:

Rough Brass

Polished Chrome*

Threads:

- 2 1/2" FNPT x FNPT
 - x MNST
 - x MBCT
 - x MQST
 - x MONT
 - x MPHX
 - x MTEM
 - x MCLV
 - x MNYFD
 - x MDET
 - x MCF
 - x MRCH
- 2 1/2" GRV x FNPT
 - x MNST
 - x MQST
 - x MNYFD
- 2 1/2" FNPT x 3 MNST
- 1 1/2" FNPT x FNPT
 - x MNST

*Contains lead. Not for use in water systems intended for human consumption.



FPPI
An ASC Engineered Solution

PROJECT INFORMATION	APPROVAL STAMP
Project:	Approved
Address:	Approved as noted
Contractor:	Not approved
Engineer:	Remarks:
Submittal Date:	
Notes 1:	
Notes 2:	

Angle Hose Valves Fig. 07-000

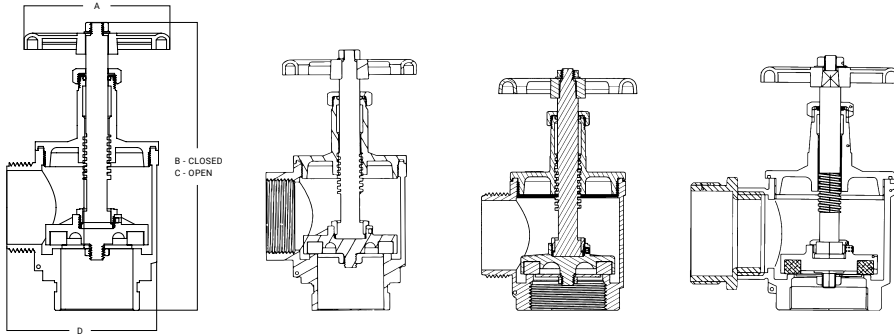

Item Number	Configuration	A (IN)	A (MM)	B (IN)	B (MM)	C (IN)	C (MM)	D (IN)	C (MM)
07-000-00	2 1/2" FNPT X MNST	5"	127	8.64"	219.5	10.41"	264.5	5.2"	132
07-000-10	2 1/2" FNPT X MNST (PC)	5"	127	8.64"	219.5	10.41"	264.5	5.2"	132
07-001-00	2 1/2" GRV X MNST	5"	127	9.42"	239.3	11.2"	284.3	5.12"	130
07-001-02	2 1/2" GRV X MQST	5"	127	9.42"	239.3	11.2"	284.3	5.12"	130
07-001-03	2 1/2" GRV X MNYFD	5"	127	9.42"	239.3	11.2"	284.3	5.12"	130
07-002-00	2 1/2" FNPT X MBCT/ NYCORP	5"	127	8.64"	219.5	10.41"	264.5	5.2"	132
07-003-00	2 1/2" FNPT X MNYFD	5"	127	8.64"	219.5	10.41"	264.5	5.2"	132
07-004-00	2 1/2" FNPT X MQST	5"	127	8.64"	219.5	10.41"	264.5	5.2"	132
07-005-00	2 1/2" FNPT X MRCH	5"	127	8.64"	219.5	10.41"	264.5	5.2"	132
07-006-00	2 1/2" FNPT X MONT	5"	127	8.64"	219.5	10.41"	264.5	5.2"	132
07-008-00	2 1/2" FNPT X MPHX	5"	127	8.64"	219.5	10.41"	264.5	5.2"	132
07-010-00	2 1/2" FNPT X MTEM	5"	127	8.64"	219.5	10.41"	264.5	5.2"	132
07-012-00	2 1/2" FNPT X MCLV	5"	127	8.64"	219.5	10.41"	264.5	5.2"	132
07-014-00	2 1/2" FNPT X MDET	5"	127	8.64"	219.5	10.41"	264.5	5.2"	132
07-016-00	2 1/2" FNPT X MCF	5"	127	8.64"	219.5	10.41"	264.5	5.2"	132
07-020-00	2 1/2" FNPT X FNPT	5"	127	8.64"	219.5	10.41"	264.5	5.2"	132
07-021-00	2 1/2" GRV X FNPT	5"	127	9.42"	239.3	11.2"	284.3	5.12"	130
07-022-00	1 1/2" FNPT X MNST	3.89"	98.8	6.71"	170.4	7.81	198.5	3.84"	97.5
07-024-00	1 1/2" FNPT X FNPT	3.89"	98.8	6.71"	170.4	7.81	198.5	3.84"	97.5
07-050-00	2 1/2" FNPT X 3 MNST	5"	127	8.64"	219.5	10.41"	264.5	7.74"	196.5

Hose Valve Caps – Plastic (ABS) with Chain Fig. 07-280



Specifications

Materials:

Cap: Injection Molded ABS
Chain: Zinc plated steels

Sizes:

2 1/2" NST
1 1/2" NST

Color

Red

Inscription:

Do Not Pressurize

Description

Plastic hose valve caps are intended to be used in place of brass or bronze caps. Because of the plastic materials low scrap value, theft and vandalism are significantly reduced. Both size caps feature rocker lug design and are provided with an attaching chain.

Installation

INTENDED ONLY FOR USE WITH NST THREADS. Make sure valve threads are free from debris. Thread correct size cap onto the valve until tight. Attach chain to the valve body at the point provided by the valve manufacturer. CAUTION: PLASTIC HOSE VALVE CAPS ARE FOR PROTECTION OF THE MALE THREAD ONLY. DO NOT PRESSURIZE PLASTIC HOSE VALVE CAPS. SERIOUS BODILY INJURY CAN OCCUR.

The information contained herein is produced in good faith and is believed to be reliable but is provided for guidance and information purposes only. FPPI and its agents cannot assume liability or responsibility for results obtained in the use or misuse of its product by persons whose methods and qualifications are outside and beyond our control. It is the user's responsibility to determine the suitability of, methods of use, preparation prior to use, and appropriate installation for all products purchased from FPPI. It is the user's sole responsibility to observe and adapt such precautions as may be advisable or necessary for the protection of personnel and property in the handling and use of any of our products.



PROJECT INFORMATION	APPROVAL STAMP
Project:	Approved
Address:	Approved as noted
Contractor:	Not approved
Engineer:	Remarks:
Submittal Date:	
Notes 1:	
Notes 2:	