



TECHNICAL DATA

**MODEL EG-100
ESFR SPRINKLER GUARD/
WATER SHIELD**

The Viking Corporation, 210 N Industrial Park Drive, Hastings MI 49058
 Telephone: 269-945-9501 Technical Services: 877-384-5464 Fax: 269-818-1680 Email: techsvcs@vikingcorp.com
 Visit the Viking website for the latest edition of this technical data page www.vikinggroupinc.com

1. DESCRIPTION

Viking ESFR Sprinkler Guards/Water Shields are used in conjunction with ESFR style sprinklers where allowed by the approvals. (Refer to the Approval Charts) The guard/water shield is a hard-wire cage with an integrated carbon steel plate designed to surround the sprinkler and protect it from mechanical damage as well as water spray from above. The guard/water shield is recommended for areas where sprinklers are installed at a low elevation and/or near a high degree of human or mechanical activity as well as where water shielding is required.



2. LISTINGS AND APPROVALS



FM Approved: Class 2091

The Model EG-100 Sprinkler Guard/Water Shield is ONLY Approved for use with the following sprinklers: VK506, VK510, and VK514
 The EG-100 is also FM approved for intermediate-level use, such as in-rack, under conveyors, mezzanines, or other similar obstructions. Refer to the Approval Chart.

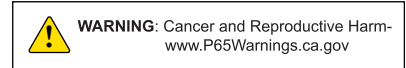

3. TECHNICAL DATA

Available since 2020

Material Standards:

Water shield (flat steel): Carbon Steel

Guard (wire): Cold Drawn Steel Wire

Screw: 6-32 x 3/8 (R.H. Phillips-Slotted Combination Drive): Steel

Screw Finish: Zinc Plate

Rivet: Carbon Steel

Pins: Carbon Steel

Ordering Information:

TABLE 1: ORDERING INFORMATION AND DIMENSIONS

Part Number	Description	Size
		NPT
24988F	ESFR Guard/Water Shield, Chrome	1"
24988M/R	ESFR Guard/Water Shield, Red	1"

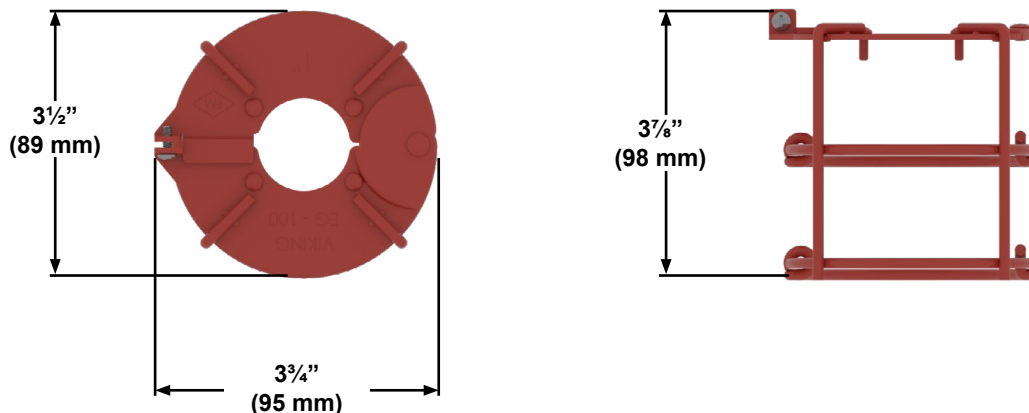

Figure 1: Dimensions
 All dimensions are approximate.



TECHNICAL DATA

**MODEL EG-100
ESFR SPRINKLER GUARD/
WATER SHIELD**

The Viking Corporation, 210 N Industrial Park Drive, Hastings MI 49058
Telephone: 269-945-9501 Technical Services: 877-384-5464 Fax: 269-818-1680 Email: techsvcs@vikingcorp.com
Visit the Viking website for the latest edition of this technical data page www.vikinggroupinc.com

4. INSTALLATION

NOTICE

Improper installation can impede the sprinkler operation.
▶ Follow the procedures in this document to properly install the sprinkler guard/water shield.

Installing the ESFR Sprinkler Guard/Water Shield on the Sprinkler

Tool needed:

#2 R.H. Phillips or Flat Head screwdriver (not available from Viking.)

Procedure:

1. Loosen the screw and open the guard/water shield.
2. Place the guard/water shield around the sprinkler as shown. Be sure the pins line up with the sprinkler frame as shown.

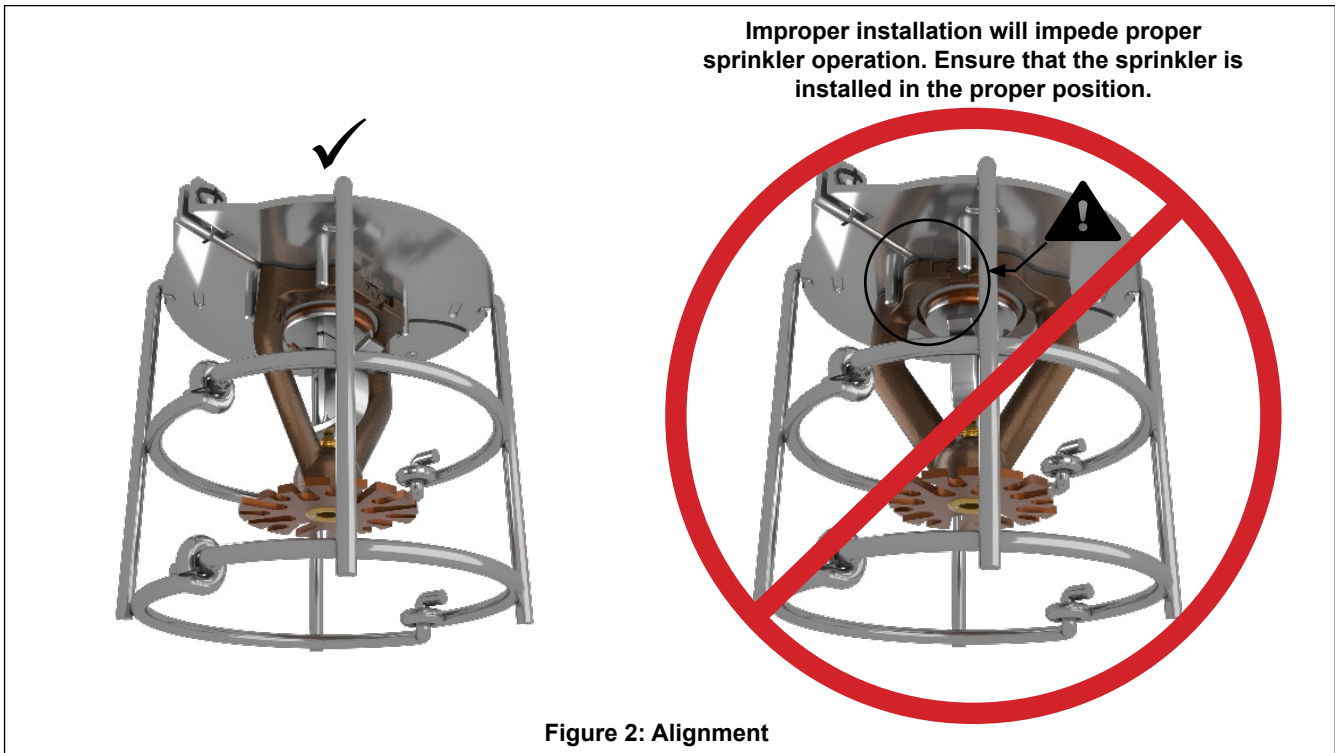

	TECHNICAL DATA	MODEL EG-100 ESFR SPRINKLER GUARD/ WATER SHIELD
---	-----------------------	--

The Viking Corporation, 210 N Industrial Park Drive, Hastings MI 49058
 Telephone: 269-945-9501 Technical Services: 877-384-5464 Fax: 269-818-1680 Email: techsvcs@vikingcorp.com
 Visit the Viking website for the latest edition of this technical data page www.vikinggroupinc.com

3. Close the guard/water shield and tighten the screw.

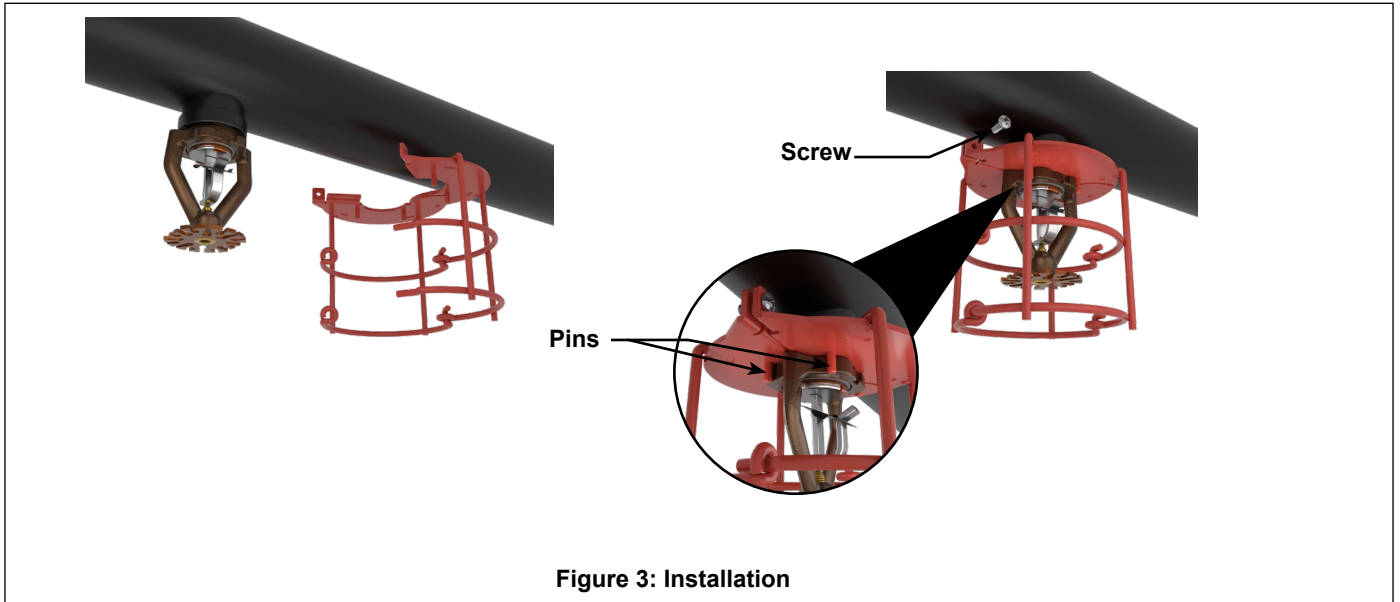

5. OPERATION

Refer to the sprinkler technical data page for the sprinkler model used. The ESFR Sprinkler Guard/Water Shield is a hard-wire cage designed to surround the sprinkler and protect it from mechanical damage as well as water spray from above.

6. INSPECTIONS, TESTS, AND MAINTENANCE

Refer to NFPA 25 for Inspection, Testing and Maintenance requirements.

7. AVAILABILITY

Viking ESFR Sprinkler Guard/Water Shield are available through a network of domestic and international distributors. See the Viking website for the closest distributor or contact Viking.

8. GUARANTEE

For details of warranty, refer to the current list price schedule or contact us directly.

Approval Chart						
Model EG-100 Sprinkler Guard/Water Shield with VK506, VK510, and VK514						
SIN	Type	Available Thread Sizes		Nominal K-Factor		Approvals
		NPT	BSPT	U.S.	metric	FM ¹
VK506	ESFR Pendent	1"	25mm	22.4	320	✓
VK510	ESFR Pendent	1"	25mm	25.2	363	✓
VK514	ESFR Pendent	1"	25mm	28.0	404	✓

1. FM approved for intermediate-level use, such as in-rack, under conveyors, mezzanines, or other similar obstructions.