

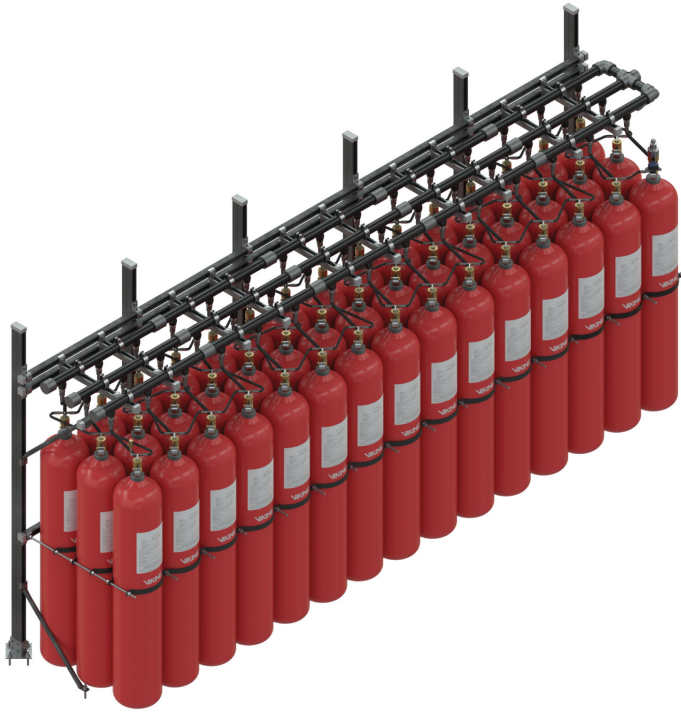

Design, Installation, Operation, and Maintenance Manual

Oxeo™ Inert Gas Extinguishing System





WARNING

This document contains important information regarding the design, installation, operation, maintenance, and regulation of the system.

- Fully read and understand the entire document and any associated documents delivered with system components before starting any work.



WARNING

Installing or servicing fire protection products contained in this system can expose you to chemicals including chromium, which is known to the state of California to cause cancer and birth defects or other reproductive harm. For more information, go to www.P65Warnings.ca.gov

The Viking Corporation
210 N. Industrial Park Dr.
Hastings, MI 49058
USA
Phone: 269-945-9501
Fax: 269-818-1680
www.vikinggroupinc.com
www.supplynet.com

Document ID: F_021023
Revision: 03
Release date: 08/2024
Language: English (U.S.)

OXEO is a trademark of Minimax GmbH.

Table of Contents

1 Safety	7
1.1 Safety Messages.....	8
1.2 Safety Notices within Procedures	9
1.3 Operational Safety	10
1.4 General Safety	11
1.5 System-specific Design Specifications.....	15
1.6 Personal Protective Equipment (PPE)	16
1.7 Safety and Protective Devices	17
1.8 Signage.....	19
1.9 Environmental Protection	24
1.10 Fire safety Measures.....	24
2 General.....	27
2.1 Information About This Manual	28
2.2 About This Document.....	28
2.3 Intended Use.....	29
2.4 Important Information	31
2.5 Additional Regulation Considerations	32
2.6 Requirements for Detection and Control Panels.....	33
2.7 Changes.....	33
2.8 Copyright.....	33
2.9 Approval Checklists.....	33
3 Characteristics of the System	35
3.1 Personal Safety in the Protected Enclosure.....	36
3.2 Personal Safety at the Installation Site	36
3.3 System limits	36
3.4 Protection Zone Seal Tightness	42
3.5 Door Fan Test	43
3.6 Considerations for Air-conditioned Enclosures	43
3.7 Requirements for Detectors and Control Panel	44
3.8 Pressure Relief Vent	44
3.9 Temperature-pressure Curves For Cylinders.....	46
4 Transport, Packaging and Storage	49
4.1 Eccentric Center of Gravity	50
4.2 Improper Transport of Hazardous Goods	50
4.3 Transport Inspection	51
4.4 Transport.....	52
4.5 Packaging	56

4.6 Storage.....	57
5 Design of Inert Gas Extinguishing Systems.....	59
5.1 Project Procedure.....	60
5.2 Determining Extinguishing Agent Quantity.....	60
5.3 System Piping Design	61
5.4 Post-discharge Venting Requirements.....	64
6 Assembly and Installation.....	65
6.1 Introduction.....	66
6.2 Warnings for Assembly and Installation	66
6.3 Requirements Imposed on the System Piping	69
6.4 Manifold Assembly	72
6.5 System Assembly - Extinguishing Agent Containers	73
6.6 Mounting the Supervised Pressure Gauge	78
6.7 Installing the Discharge Hose.....	80
6.8 Fitting Modification	82
6.9 Installing the Pilot Hose.....	84
6.10 Installing the Releasing Solenoid to the Primary Valve.....	90
6.11 Occupiable Space Kit.....	93
6.12 Installing the Manifold Relief Valve and Lockout Valves	109
6.13 Installing the Nozzles	110
6.14 Multi-zone Assembly	113
7 Electrical Connections	115
7.1 Supervisory Switches	117
8 Commissioning	121
8.1 Preparations	123
8.2 Testing the Function of Releasing Solenoid.....	124
8.3 Testing the Function of the Selector Valve.....	125
8.4 Testing Function of Control Unit MZ-1	126
8.5 Checking Pneumatic Time Delay Function	129
8.6 Checking the Function of the Pneumatic Horn (Makrofon).....	131
8.7 Establishing Operational Readiness	131
9 Design, Function, and Operation.....	133
9.1 Functional Description.....	134

9.2 Oxeo Unistrut Racking Arrangements.....	137
9.3 System piping.....	138
9.4 Manifolds, 2" NPT	139
9.5 Check Valve	140
9.6 Extinguishing Cylinder with Quick Release Valve.....	140
9.7 Hose for Extinguishing Agent.....	146
9.8 Pilot Hoses for Activation of Secondary Cylinder.....	147
9.9 Selector Valves	149
9.10 Monitored Lock Out.....	150
9.11 Pressure Reducer (PR Systems Only).....	151
9.12 Constant Flow Regulator (CF Systems Only)	153
9.13 Manifold Safety Valve	154
9.14 Occupiable Space Protection Kit.....	155
9.15 Pilot Cylinder	159
9.16 Shuttle non-return valve	160
9.17 Pilot pressure relief assemblies	161
9.18 Multi-zone Control Unit MZ-1	163
9.19 Lock Out Device, Pilot Line	164
9.20 System Piping	165
9.21 Pneumatic Limit Switch.....	165
9.22 Nozzles	166
9.23 Overview of System Limits.....	172
9.24 Resetting System Isolation in the Event of Fire	173
9.25 Types of System Activation.....	173
9.26 Actions After the System is Activated	176
9.27 Main/reserve Change-over.....	178
10 Inspection, Servicing, and Cleaning	181
10.1 Inspection and Maintenance Schedule	186
10.2 Service Report	192
10.3 Activities Before Servicing.....	192
10.4 Taking the System Out of Service.....	193
10.5 Visual inspections	193
10.6 Refilling	195
10.7 Cleaning.....	197
11 Malfunctions.....	199
11.1 Warnings Regarding Troubleshooting.....	200
11.2 Fault Indicators.....	201
11.3 Malfunction Tables	201

11.4 Correct Supervised Pressure Gauge Display.....	207
11.5 Putting the System Back into Operation.....	208
12 Disassembly and Disposal.....	209
12.1 Disassembly.....	212
12.2 Disposal.....	219
13 Appendix A - Replacement Components.....	221
13.1 Replacement component part numbers	222
14 Appendix B - Racking Assembly	227
14.1 Introduction.....	228
14.2 Racking Configurations and Ordering Information	228
14.3 Spare Parts And Component Technical Data	232
14.4 Assembling the Rack.....	238
15 Safety Data Sheet - IG-01 (Argon).....	249
15.1 SDS - ARGON.....	250
16 Safety Data Sheet - IG-100 (Nitrogen)	257
16.1 SDS-Nitrogen	258
17 Component Product Sheets	265
17.1 Cylinder Assemblies.....	266
17.2 Pilot Cylinders	276
17.3 Manifolds	280
17.4 Check Valve	282
17.5 Check Valve Cap.....	283
17.6 Discharge Hose Kits (PR and CF).....	284
17.7 Discharge Hose Kit (CF Only)	286
17.8 Pneumatic Limit Switch	288
17.9 Pilot Hoses	290
17.10 Manifold Pressure Relief (957 psi)	292
17.11 Manifold Pressure Relief (2901 PSI)	294
17.12 Manifold Pressure Relief (4351 psi)	297
17.13 Pilot Line Pressure Relief	299
17.14 Pilot Line Lock-out Valve.....	301
17.15 Agent Supply Lock-Out Valves.....	304
17.16 Shuttle Non-Return Valve.....	306

17.17 Pressure Reducer	308
17.18 Pressure Gauges	310
17.19 Releasing Solenoid	313
17.20 Reset Tool.....	316
17.21 Release Solenoid Monitor Device	317
17.22 Manual Release Device	319
17.23 Warning Signs.....	321
17.24 VN Nozzles	324
17.25 DCM Nozzle.....	334
17.26 Occupiable Space Kit.....	339
17.27 Pressure Reducer (PR).....	342
17.28 Pneumatic Time Delay	344
17.29 Pneumatic Horn	347
17.30 MZ-1.....	351
17.31 Selector Valve	356



1 Safety

This section provides an overview of all important aspects that are essential for the protection of personnel as well as safe and efficient operation. Additional task-specific safety instructions will be provided in the sections that refer to the individual stages of the installation process.

1.1 Safety Messages

Safety and warning notices are marked with symbols and signal words in this document. The signal words express the respective extent of the danger.



This is the safety symbol. It is used to alert you to potential risks to personal safety. Follow all instructions that follow this symbol.



DANGER

The signal word describes a danger with a high risk level. If the danger is not avoided, it will result in death or serious injury.



WARNING

The signal word describes a danger with a high risk level. If the danger is not avoided, it may result in death or serious injury.



CAUTION

The signal word describes a danger with a low risk level. If the danger is not avoided, it may result in minor or moderate injury.

NOTICE

Used without the safety symbol, *NOTICE* describes a situation with a low risk level. If the situation is not avoided, it may result in property and environmental damage.



This marking emphasizes useful tips and recommendations as well as information for safe operation.

1.2 Safety Notices within Procedures

Safety messages used within specific procedures refer to safe practices pertaining to that particular procedure. The signal words described in “Safety Messages” on page 8 are used within procedures without the safety symbol. Such messages are embedded within procedures so that they do not interrupt the reading flow when executing the action.

Example:

1. Install the new widget.
2. Completely tighten the widget.

WARNING Keep hands clear of the newly installed widget when turning on the power.

3. Turn on the power.

1.3 Operational Safety

If system components are used improperly or for any use other than their intended purpose, the system can pose hazards or be impaired. Only use undamaged and fully functional products and parts. If safe operation can no longer be assured (for example, if visible damage is present), put the system out of operation immediately and secure against accidental discharge.

Also observe the following:

- Use only the original or the provided spare parts or Viking approved equivalents.
- Immediately replace parts that are not in perfect condition.
- Do not carry out any changes, extensions or modifications without the express permission of the manufacturer. This also applies to welding work on load-bearing parts.



CAUTION

Any changes, extensions or modifications not approved by the manufacturer are the sole responsibility and liability of the person making the modification and exclude any responsibility of the manufacturer.

Also observe the following fundamental information:

- National safety regulations
- National accident prevention regulations
- National assembly and installation regulations
- Generally accepted technical principles
- Safety and warning notices as described in this document
- Demands on personnel as described in this document

1.4 General Safety

The following section describes hazards that can arise from the system.

Follow the safety procedures listed here and throughout this document to reduce risk of personal injury and property damage.

1.4.1 Electrical



DANGER

Risk of death due to electric shock

Risk of death due to electric shock exists if live components are touched. Damage to individual components poses a hazard that will lead to fatal injury. Incorrect connection can cause system malfunctions.

- **If there is damage to an electrical component, immediately shut off the power supply and replace defective components with new parts.**
- **Allow only qualified electricians to work on electrical components connections.**
- **Always disconnect power to the component before starting any work. In this process comply with the 5 following safety rules:**
 1. Disconnect power.
 2. Follow all applicable lock-out procedures.
 3. Verify that the component has been de-energized.
 4. Ground and short circuit.
 5. Cover or shield any adjacent live components.
- **Never remove safety devices, change them, or render them inoperable.**
- **Keep moisture away from electrical components.**

1.4.2 Oxygen deficiency



WARNING

Risk of death due to oxygen deficiency

If the extinguishing agent concentration exceeds 52% by volume, the Lowest Observed Adverse Effect Level (LOAEL) has been reached and the extinguishing agent can have a toxic effect due to the reduced oxygen concentration. A danger of asphyxiation exists with extinguishing agent concentrations above 52% by volume.

- Comply with No Observed Adverse Effect Level (NOAEL) and LOAEL limit values found in Table 1-1 on page 12
- Do not purposefully inhale vapors, aerosols, and atomized spray.
- Comply with the safety data sheet for the extinguishing agent.
- Comply with all listed concentration/egress time safety limits as specified in NFPA 2001.

The following toxicity characteristic values apply for inert gases (e.g. nitrogen or argon):

Refer to the most current version of NFPA 2001 for more information.

Table 1-1: Toxicity Characteristic Values for Extinguishing Agents

Extinguishing agent	NOAEL in vol-% of extinguishing agent	LOAEL in vol-% of extinguishing agent	Density at 68 °F (20 °C) and 14.7 psi (1013 mbar)
IG-100 (nitrogen)	43.0 ¹⁾	52.0 ²⁾	0.07273 lb/ft ³ (1.165 kg/m ³)
IG-01 (argon)	43.0 ¹⁾	52.0 ²⁾	0.10376 lb/ft ³ (1.662 kg/m ³)
¹⁾ corresponds to 12 vol.% of oxygen ²⁾ corresponds to 10 vol.% of oxygen			

1.4.3 Pressurized cylinders



WARNING

Risk of death due to pressure in extinguishing agent cylinders.

If pressurized extinguishing agent cylinders are damaged and extinguishing agent escapes uncontrollably, there is a risk of severe injury or death.

- Do not transport or store extinguishing agent cylinders unless they are sealed with a protective valve cap and an outlet venting safety plug.
- Ensure that the extinguishing agent cylinders are attached correctly.
- Immediately replace damaged extinguishing agent cylinders.

1.4.4 Cold extinguishing agent



WARNING

Risk of injury from cold extinguishing agent.

The extinguishing agent exiting at the discharge nozzles is very cold. Direct contact may result in injury.

- Immediately leave the extinguishing zone.
- Stay out of the direct flow area of a discharge nozzle.
- Do not attach/store components that are sensitive to cold in the immediate vicinity of the discharge nozzles.

1.4.5 Accidental discharge



WARNING

Risk of injury from accidental discharge.

An accidental discharge of the system may cause severe injuries and property damage.

- **Activate the system only in the event of a fire.**
- **Protect the manual release devices in the protected enclosure from accidental discharge.**
- **Do not smoke inside the protected enclosure.**
- **Before performing any work that generates heat and smoke, observe the following:**
 1. **Isolate the system.**
 2. **Switch off the fire alarm system.**

1.4.6 Falling and flying objects



WARNING

Risk of injury from falling and flying objects.

The discharge velocity of the extinguishing agent may cause objects to tip over, become airborne, or be damaged. This can cause severe injuries and significant product damage.

- **Immediately leave the extinguishing zone.**
- **Do not place any loose objects near the nozzles.**
- **Do not place any sensitive objects (e.g. hard drives) near the nozzles.**

1.4.7 Noise



WARNING

Risk of injury from noise.

High sound pressure levels caused by discharged gas and acoustic alarm equipment (e.g. signal horns) may cause hearing damage.

- Immediately leave the extinguishing zone.

1.4.8 Excess pressure

NOTICE

Property damage from excess pressure.

Upon system activation, excess pressure is created within the protected area. Damage to walls and doors of the area can occur.

- Ensure that pressure relief devices are installed in the protected enclosure and included in the design of the system.
- Make sure that the function of the pressure relief is checked regularly.
- Ensure all venting calculations conform to ISO 21805.

1.5 System-specific Design Specifications

The system is composed of several approved components. Please consult the installing contractor when planning structural modifications to the system/protected enclosure.



Never perform any structural modifications or use the protected enclosure for other purposes without consulting a fire protection professional.

1.6 Personal Protective Equipment (PPE)

PPE is designed to protect people from workplace safety and health hazards.

Personnel must wear PPE, which is specifically indicated in the individual sections of this document, when carrying out the various tasks.

PPE is described in the following sections:

1.6.1 Hearing protection

Hearing protection serves to protect hearing from high sound levels.

1.6.2 Industrial hard hat

Industrial hard hats protect the head against falling objects, hanging loads and bumping against stationary objects.

1.6.3 Protective goggles

Protective goggles cover the entire area of the eyes and are used to protect the eyes from the extinguishing agent and any other harmful particulate displaced by system activation.

1.6.4 Safety footwear

Safety footwear protects the feet from crushing injuries, falling parts, and slipping on slippery surfaces.

1.6.5 Safety gloves

Safety gloves are used to protect the hands from friction, abrasions, puncture wounds, or deeper wounds, as well as coming into contact with hot and/or cold surfaces.

1.6.6 Safety goggles

Safety goggles cover the entire eye area and are used to protect the eyes, e.g. against chemicals, raised particles or pressurized gases or liquids.

1.6.7 Self-contained breathing apparatus

The self-contained breathing apparatus is used to protect against harmful gases, fumes, dusts, and similar materials and media. Breathing protection isolation devices (e.g. air breathing apparatuses) must be used if a minimum oxygen content required by locally-applicable regulations is not guaranteed in the ambient atmosphere or if there is a dangerously high extinguishing agent concentration. Refer to applicable regulations.

Respiratory protective devices should only be used by specially trained personnel.

1.7 Safety and Protective Devices



WARNING

Risk of injury due to non-functioning safety devices.

If safety devices are not functioning or have been rendered inoperable, there is risk of severe injury and considerable material damage.

- **Before starting work, check whether all safety devices are functioning and correctly installed.**
- **Never disable or bypass safety devices.**

The system has various safety devices that are described below.

Burst disks

Burst disks are safety devices that protect a container from excess pressure. If a critical pressure level is exceeded, the disk bursts and the excess pressure dissipates.

If a burst disk ruptures, the quick release valve must be replaced with a new valve.

Pressure relief vents

Pressure relief vents are installed in the exterior walls of buildings to dissipate the change in pressure that occurs when the system is activated.

Pressure relief vents are closed in idle position. If the pressure level goes over a specified value, the pressure relief vents open and ensure that the pressure is relieved. All vents must conform to ISO 21805.

Check valve

Check valves permit the flow of extinguishing agent in the correct direction and prevent it in the opposite direction. They are located between the hose and the manifold in a

Pressure Reduced system. In a Constant Flow system, they are located between the regulator and the manifold.

Pilot pressure relief device

The pilot pressure relief device dissipates a slow increase in pressure via a vent bore. Slow gas leaks can occur if there are leaks in the extinguishing agent container. The pilot pressure relief device closes automatically during system activation.

Manifold safety valve

Manifold safety valves are required in all systems for the protection of the system piping.

In the event of excessively high pressure, the manifold safety valve ensures pressure escape. The blow-off lines connected to the manifold safety valve safely dissipate the medium.

Protective valve caps

Protective valve caps are used to protect sensitive components (e.g. valves) of the extinguishing agent containers. They prevent the valves from being damaged during transport. The protective valve caps must be attached when transporting the cylinder, or any time the cylinders are not secured.

Outlet venting safety plug

The outlet venting safety plug seals the valve outlet (e.g. during transport or storage) so that extinguishing agent does not escape in an uncontrolled manner in the event of unintentional activation.

The outlet venting safety plugs are connected to the valves by means of loss protection devices.

1.8 Signage

The following symbols and information signs should be displayed in the appropriate area.



WARNING

Risk from illegible or missing signs.

Over time, stickers and signs can become dirty or unreadable. Risks that pertain to unreadable signage can no longer be recognized and necessary operating instructions can no longer be adhered to, which will lead to risk of injury.

- Keep all safety, warning and operating instructions easily readable at all times.
- Immediately replace damaged signs or labels.

Extinguishing zone designation

The extinguishing zones must be marked to indicate the presence of the fire extinguishing system and the potential risks.

Signs for both nitrogen and argon systems are available (nitrogen pictured below). Signs are available in English, Spanish, and French.

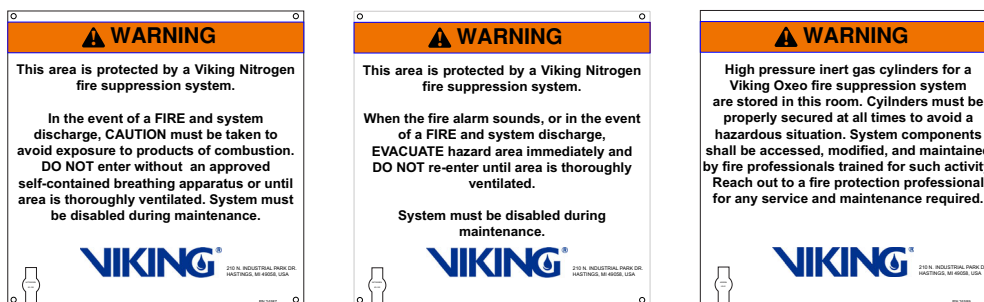

Figure 1.1: Extinguishing zone designation signage

Non-toxic, non-flammable gas under pressure

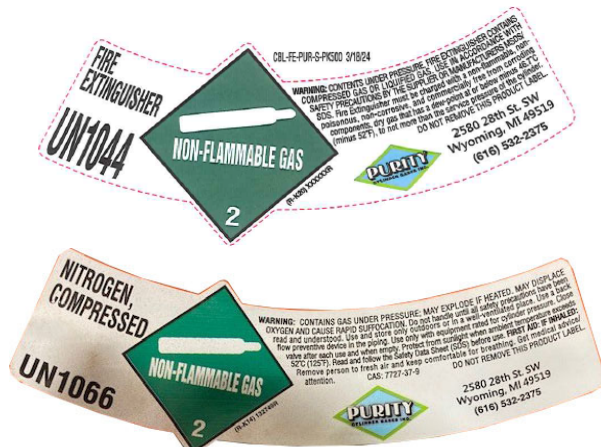

Figure 1.2: Non-flammable gas label



WARNING

Risk of death due to oxygen deficiency

If the extinguishing agent concentration exceeds 52% by volume, the Lowest Observed Adverse Effect Level (LOAEL) has been reached and the extinguishing agent can have a toxic effect due to the reduced oxygen concentration. A danger of asphyxiation exists with extinguishing agent concentrations above 52% by volume.

- Comply with No Observed Adverse Effect Level (NOAEL) and LOAEL limit values found in Table 1-1 on page 12
- Do not purposefully inhale vapors, aerosols, and atomized spray.
- Comply with the safety data sheet for the extinguishing agent.
- Comply with all listed concentration/egress time safety limits as specified in NFPA 2001.

This hazard pictogram indicates containers filled with pressurized gas, which can explode if they are heated. Inhaling high concentrations of these gases is hazardous to a person's health. Non-flammable gas labels like the label shown in Figure 1.2 on page 20 may differ than the label that appears on the extinguishing agent cylinder. Refer to Table 1-1 on page 12 for more information.

**WARNING**

Risk of death due to pressure in extinguishing agent cylinders.

If pressurized extinguishing agent cylinders are damaged and extinguishing agent escapes uncontrollably, there is a risk of severe injury or death.

- **Do not transport or store extinguishing agent cylinders unless they are sealed with a protective valve cap and an outlet venting safety plug.**
- **Ensure that the extinguishing agent cylinders are attached correctly.**
- **Immediately replace damaged extinguishing agent cylinders.**

Protect the containers from tipping over and falling down as well as from heating, impact, and shock.

Pilot cylinder label

Each pilot cylinder includes a specification label, shown in Figure 1.3 on page 22.

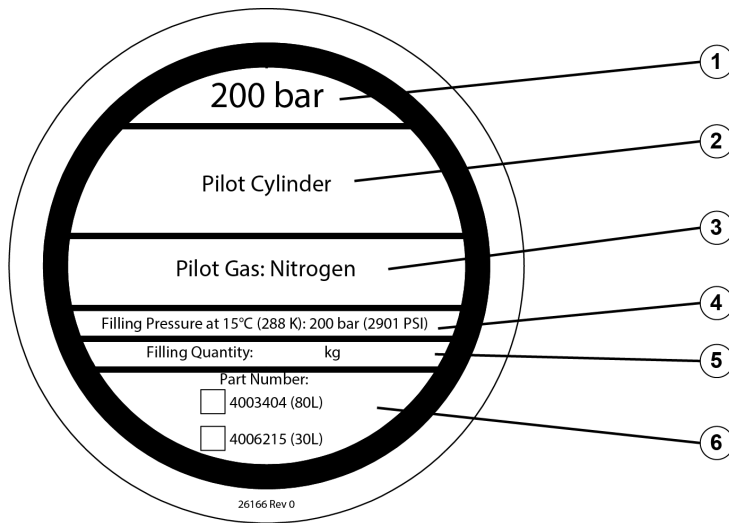

Figure 1.3: Pilot cylinder label

1	Nominal pressure [bar]	4	Filling pressure at 59° F (15 °C) [bar]
2	Designation: pilot cylinder	5	Filling quantity [kg]
3	Pilot gas: nitrogen	6	Part number of the pilot cylinder

Extinguishing agent cylinder label (FM/UL)

Each extinguishing agent container includes a UL/FM required specifications label shown in Figure 1.4 on page 23.

The image shows a detailed label for a Clean Agent Extinguishing System Unit (34YN). At the top, it features three logos: FM APPROVED, UL LISTED, and ULC LISTED. Below the logos, the text reads 'CLEAN AGENT EXTINGUISHING SYSTEM UNIT 34YN'. The label contains a table with columns for 'IG-01 (Argon)' and 'IG-100 (Nitrogen)'. The table has rows for 'Operating pressure at 70°F (21°C)', 'Model number (order number)', 'Weight of agent charge', 'Gross weight of charged cylinder and valve assembly', 'Design, Installation, Operation, and Maintenance Manual (DIOM)', and 'Fill station'. Below the table, there are several paragraphs of text, including 'WARNING: Avoid exposure to vapors, fumes, and products of combustion', 'MISE EN GARDE: Éviter toute exposition aux vapeurs, aux fumées et aux produits de combustion', 'SAFETY INSTRUCTIONS:', and 'IF CONTAINER CONTENTS MUST BE REMOVED FOR SERVICE, MAINTENANCE OR DISMANTLING OF THE CLEAN AGENT SYSTEM - PRIOR TO REMOVAL, CONTACT YOUR LOCAL INSTALLER OR MANUFACTURER FOR INSTRUCTIONS CONCERNING THE EQUIPMENT AND CLEAN AGENT.' At the bottom, it says 'DO NOT COVER, REMOVE OR DEFACE THIS LABEL' and 'Viking Corporation, 210 N. Industrial Park Drive, Hastings MI 49058'. Seven numbered callouts (1-7) point to specific parts of the label: 1 points to the agent type selection, 2 to the operating pressure, 3 to the model number, 4 to the weight of agent charge, 5 to the gross weight, 6 to the manual reference, and 7 to the fill station.

Figure 1.4: Extinguishing agent cylinder label (FM/UL)

1	Type of extinguishing agent	5	Overall weight of the extinguishing agent container
2	Operating pressure at 70 °F (21 °C)	6	Part number of the manual
3	Order number of the extinguishing agent container	7	Fill station
4	Weight of extinguishing agent charge		

1.9 Environmental Protection

Refer to the safety data sheets (SDS) of the extinguishing agent(s) for information on environmental protection.



The safety data sheets (SDS) are provided with each delivery and can be obtained from the manufacturer.

1.10 Fire safety Measures

Preventive measures

- Always be prepared for fire and accidents.
- Always keep first-aid supplies (first-aid kit, blankets, etc.) and replacement extinguishing equipment (e.g. fire extinguishers) in good working condition and within easy reach.
- Familiarize personnel with accident reporting, first-aid, rescue equipment, and manual system activation.

Measures in the case of fire



WARNING

Danger to life due to fire.

When a fire breaks out and during extinguishing operations, severe fire smoke can build up. Being present in a gaseous agent flooding zone in the event of a fire may result in severe respiratory injury or even death by suffocation.

- **Immediately leave the flooding zone.**
- **Only access the flooding zone again once permitted by the fire department.**

When the system alarm devices have been activated (main alarm), a pre-warning time (usually 30 - 45 seconds) starts to run down. Pre-warning time may vary with local regulations. Refer to AHJ for details. After this pre-warning time elapses, the system actuates.

Take the following measures if fire breaks out:

- If there is no danger posed to your own health, actuate the system manually if there is evidence of a smoke/fire build-up.
- If there is no danger posed to your own health, rescue people from the danger zone.
- Immediately leave the extinguishing zone.
- Begin applying first-aid measures if required.
- Warn people who are in danger in adjacent areas.
- Alert the fire department and/or rescue service.
- Inform the person responsible on-site.
- Keep access roads for rescue vehicles clear.

2 General

2.1 Information About This Manual

This manual describes the design, installation, operation, and maintenance of the Oxexo Pressure Reducing (PR) and Constant Flow (CF) inert gas extinguishing system. Hereafter Oxexo PR and CF inert gas extinguishing system will be referred to as “system;” if only one type of system is affected, the designation between PR and CF will be stated clearly. Information about fire detection and electrical control is not part of this manual. Knowledge of both the technical details of the system and the extinguishing agent used are prerequisites for working with this manual.

2.2 About This Document

This document contains all information necessary to correctly install, maintain, operate, and design the system described. To ensure safe working conditions, observe all safety information and instructions before interacting with the system. In addition to the information within this document, refer to all applicable local accident prevention regulations and general safety laws.

If this document refers directly or indirectly to laws, regulations, or directives or quotes from them, the manufacturer cannot be held responsible for the correctness, completeness or up-to-date nature of the reference.

Observe any local guidelines, standards, or legislation specific to the location of system installation.

Underwriters Laboratories is a safety organization that sets industry-wide standards for new products. Hereafter, Underwriter’s Laboratories will be referred to as “UL”.

FM Approvals is a global certification agency focused on property loss prevention for use in commercial and industrial facilities. Hereafter, FM Approvals will be referred to as “FM”.



The manufacturer reserves the right to make modifications resulting from further developments while retaining the key features of the system described without making corrections to this document.

Illustrations in this document are intended to facilitate basic understanding, and may differ from the actual design of the product.

2.3 Intended Use

This system is designed exclusively for the intended use described here.

The Oxexo inert gas extinguishing system is UL Listed and FM Approved for total flood applications and is intended to be used with all NFPA 2001 requirements. The system allows for the following inert extinguishing gases:

- IG-100 (nitrogen)
- IG-01 (argon)

Typical fire hazards for which the system should be used include:

- Electrical or electronic equipment
- Telecommunications equipment
- Ignitable and combustible liquids
- Other goods of particularly high value
- Application sensitive to water
- Museums
- Art Gallery
- Police Evidence Storage
- Data Center
- Switch Gear
- Rack Room
- UPS/Battery Room
- Control Room
- Rare Book/Artifacts
- Research
- Engine Test Cells
- Turbines
- Pharmaceuticals

The system should only be used within the usage and ambient conditions for which it has been designed.

Intended use also includes compliance with all instructions within this document.

Misuse

Any use that extends beyond the intended use, or any other use of the system is considered misuse.

**WARNING**

Danger due to misuse.

Misuse of the Oxeo inert gas extinguishing system can lead to personal injury and material damage.

- **Do not perform any structural modifications on the protection zone or the system without consulting a fire protection professional.**
- **Do not use and operate the system if components are damaged or not functional.**
- **Do not use the extinguishing system for any purpose other than the one intended by the installing contractor.**
- **Do not hang objects from pipe lines.**
- **Do not block the extinguishing nozzles or the ventilation devices.**

Fire hazards

Do NOT use the system in conjunction with the following fire hazards:

- Chemicals that release oxygen.
- Mixtures containing oxidizing substances (e.g. sodium chlorate, sodium nitrate, explosives, gunpowder).
- Chemicals capable of thermally decomposing autonomously (e.g. certain organic peroxides).
- Reactive metals (e.g. sodium, potassium, magnesium, titanium or zirconium) and reactive hybrids or metal amides.



In certain circumstances, some of the mentioned fire types can be suppressed using IG-01 (argon). Consult the manufacturer about this.

2.4 Important Information

The system must be designed by qualified fire protection professionals in conjunction with insuring bodies. Fire extinguishing systems are engineered to meet the standards of NFPA 2001, ISO 14520, FM 5600, and UL 2127 or other similar organizations, and will also need to comply with the provisions of governmental codes, ordinances, and technical standards where applicable. The system owner and/or their legal representative(s) for system design, installation, and approval or certification are responsible for the design and configuration of the system, its ability to comply with its intended use, and its adherence to all standards, codes, and ordinances.

The manufacturer or private labeler of the products described in this manual does not design systems for specific installations and makes no representation or warranty concerning whether any specific system installation will be sufficient for the intended use or will comply with any standard, code, or ordinance.

System depictions, calculations, graphs or reports provided by the manufacturer or private labeler of the system components are for illustrative purposes only, and are not warranted to be representative or descriptive of any specific system, installation, or design; nor the results of any such system. The manufacturer or private labeler and its representatives disclaim use of the accompanying system depictions, calculations, graphs, and reports for any purpose other than illustration. Any other application or usage is the responsibility of the owner and the user.

The installing contractor is responsible for selecting the fire extinguishing system components used and to ensure that all applicable specific listing requirements are met. It is the installing contractor's responsibility to ensure compatibility of the components used within the system, and that the components selected are used in accordance with their listings and the applicable manufacturer's instructions.

2.5 Additional Regulation Considerations

In addition to this manual, the following regulations must also be considered:

- NFPA 2001 for installation, maintenance and testing requirements
- Environmental Protection Agency's Significant New Alternatives Program (EPA's SNAP) for use of clean agents

Monitoring of the electrical release solenoids

Electrical release solenoids used as the activating mechanisms of the system are required by NFPA 2001 to be in place and ready to use.

During installation, service, and inspection it is common to demount the electrical release solenoids. Supervisory switches shall be installed to send a signal to the fire detection and extinguishing control panel if the electrical release solenoids are not in place.

- Wiring methods for the electrical release solenoids are to be in accordance with the provided installation instructions for the UL Listed fire detection and extinguishing control panel.

Requirements for electrical release solenoid accessories

Each individual electrical release solenoid is to be provided with an UL Listed supervisory switch. The supervisory switches are to be installed by qualified personnel and in accordance with NFPA 2001 for all the electrical release solenoids.

The supervisory switch must provide a supervisory signal to the fire detection and extinguishing control panel if the electrical release solenoids are not in place.

The installer must use UL certified components such as junction boxes, flexible conduits, and conduit fittings and install the system according to NFPA 70, NFPA 72, and UL 864.

2.6 Requirements for Detection and Control Panels

The components of the suppression releasing panel (hereafter referred to as SRP) must comply with the applicable local regulations.



UL Listed or FM Approved extinguishing system devices with an electric release require the use of a UL Listed or FM Approved fire detection system/ electric control device that is compatible with the release device. Likewise, all fire detection devices must also be UL Listed or FM Approved and compatible with the fire detection system/electric control device.

2.7 Changes

The information in this manual is subject to changes and updates. The illustrations contained in this manual were current at the time of publication. Screen representations and output formats shown at a later time may deviate from these illustrations.

2.8 Copyright

Any content in this document, particularly texts, photos, and graphics, are protected by copyright. If not otherwise clearly indicated, copyright lies with the manufacturer.

The manufacturer can issue permission of usage for contents of this document. Anyone violating copyright law, e.g. by copying the contents into their own documentation without the respective permission, is liable to prosecution. Copyright violators shall also receive a written warning and be liable to pay costs.

2.9 Approval Checklists

Checklists should be used to ensure all systems are in compliance with applicable standards. An example of such lists can be found in the Fire Suppression System Association (FSSA) inspection form guidelines and FSSA inspection and test guide.

3 Characteristics of the System

The specific characteristics explained in the following chapters must be considered when designing fire suppression systems.

3.1 Personal Safety in the Protected Enclosure

Comply with the specified toxicity values of the extinguishing agent to ensure the safety of personnel. See “Toxicity Characteristic Values for Extinguishing Agents” on page 12.

After the NOAEL value has been reached or exceeded for systems to be used in occupiable spaces, measures to protect personnel are required. The type and scope of the required measures are specified by NFPA 2001 and/or local regulations.

3.2 Personal Safety at the Installation Site

Extinguishing agent containers in the protection zone

If the extinguishing agent containers are to be installed in the protection zone, the applicable local personal, safety, and systems engineering requirements must be observed.

Manifold pressure reliefs

The manifold pressure relief line of the manifold safety valve must be routed out into the open. The blow-off vent must also be positioned in a way that prevents risks of personal harm from the pressurized extinguishing agent that flows out.

3.3 System limits

System limits are restrictions in regard to the arrangement and number of system components, pipeline length, and the environmental conditions under which the system can be operated.

3.3.1 Operating conditions

Table 3-1: Operating Conditions

Specification	Value ¹		Unit
	PR	CF	
Permitted temperature for arrangement of extinguishing agent containers (FM Approval requirements)	0 – 55	-11 – 55	°C
	32 – 131	12.2 – 131	°F
Permitted temperature for transport/storage of extinguishing agent containers (FM Approval requirements)	-20 – 55	-20 – 55	°C
	-4 – 131	-4 – 131	°F
Permitted temperature in extinguishing zone (FM Approval requirements)	-20 – 55	-20 – 55	°C
	-4 – 131	-4 – 131	°F
Permitted operating temperature of the system (according to UL Listed requirements)	0 – 55	0 – 55	°C
	32 – 131	32 – 131	°F

¹If locally applicable guidelines and standards define further restrictions, they take priority.

NOTICE

The system must not be exposed to outdoor weather conditions.

3.3.2 System limits according to approval

When configuring the extinguishing system, comply with the system limits in accordance with the appropriate approval.



The applicable local or national planning and installation guidelines must always be observed.

For specifications according to UL/FM and NFPA requirements:

See “Overview of System Limits” on page 169

See “Design concentration data” on page 165.

3.3.3 Equivalent lengths

Table 3-2: Equivalent length of fittings, screwed (ASTM, Schedule 40/80)

Diameter (Inches)	90° elbow [ft (m)]	Through T [ft (m)]	Side T [ft (m)]
3/8	1.31 (0.40)	0.79 (0.24)	2.69 (0.82)
1/2	1.71 (0.52)	0.98 (0.30)	3.41 (1.04)
3/4	2.20 (0.67)	1.41 (0.43)	4.50 (1.37)
1	2.79 (0.85)	1.81 (0.55)	5.71 (1.74)
1 1/4	3.71 (1.13)	2.30 (0.70)	7.51 (2.29)
1 1/2	4.30 (1.31)	2.69 (0.82)	8.69 (2.65)
2	5.51 (1.68)	3.51 (1.07)	11.19 (3.41)
2 1/2	6.60 (2.01)	4.10 (1.25)	13.39 (4.08)
3	8.20 (2.50)	5.09 (1.55)	16.60 (5.06)
4	10.70 (3.26)	6.69 (2.04)	21.79 (6.64)
5	13.39 (4.08)	8.40 (2.56)	27.40 (8.35)
6	16.21 (4.94)	10.11 (3.08)	32.81 (10.00)
8	21.59 (6.58)	13.91 (4.24)	43.21 (13.17)

Table 3-3: Equivalent length of fittings, welded (ASTM, Schedule 40/80)

Diameter (Inches)	90° elbow	Through T	Side T
	[ft (m)]	[ft (m)]	[ft (m)]
1/2	0.79 (0.24)	0.69 (0.21)	2.10 (0.64)
3/4	1.12 (0.34)	0.89 (0.27)	2.79 (0.85)
1	1.41 (0.43)	1.12 (0.34)	3.51 (1.07)
1 1/4	1.81 (0.55)	1.51 (0.46)	4.59 (1.40)
1 1/2	2.10 (0.64)	1.71 (0.52)	5.41 (1.65)
2	2.79 (0.85)	2.20 (0.67)	6.89 (2.10)
2 1/2	3.31 (1.01)	2.69 (0.82)	8.20 (2.50)
3	4.10 (1.25)	3.31 (1.01)	10.20 (3.11)
4	5.41 (1.65)	4.40 (1.34)	13.39 (4.08)
5	6.69 (2.04)	5.51 (1.68)	16.80 (5.12)
6	8.10 (2.47)	6.60 (2.01)	20.21 (6.16)
8	10.89 (3.32)	8.79 (2.68)	26.41 (8.05)

Table 3-4: Equivalent length of fittings, screwed (ISO 30)

Diameter (Inches)	90° elbow	Through T	Side T
	[ft (m)]	[ft (m)]	[ft (m)]
1/4	0.49 (0.15)	0.66 (0.20)	1.97 (0.60)
3/8	0.66 (0.20)	0.79 (0.24)	2.69 (0.82)
1/2	1.71 (0.52)	0.98 (0.30)	3.28 (1.00)
3/4	2.20 (0.67)	1.41 (0.43)	4.59 (1.40)
1	2.79 (0.85)	1.81 (0.55)	5.58 (1.70)
1 1/4	3.61 (1.10)	2.30 (0.70)	7.55 (2.30)
1 1/2	4.27 (1.30)	2.69 (0.82)	8.86 (2.70)
2	5.58 (1.70)	3.61 (1.10)	11.19 (3.41)
2 1/2	6.56 (2.00)	4.10 (1.25)	13.45 (4.10)
3	8.20 (2.50)	5.09 (1.55)	16.73 (5.10)
4	10.70 (3.26)	6.69 (2.04)	21.98 (6.70)

Table 3-5: Equivalent length of fittings, welded (ISO 30)

Diameter (Inches)	90° elbow [ft (m)]	Through T [ft (m)]	Side T [ft (m)]
1/2	0.69 (0.21)	0.69 (0.21)	2.10 (0.64)
3/4	0.89 (0.27)	0.89 (0.27)	2.79 (0.85)
1	1.08 (0.33)	1.08 (0.33)	3.61 (1.10)
1 1/4	1.51 (0.46)	1.51 (0.46)	4.59 (1.40)
1 1/2	1.71 (0.52)	1.71 (0.52)	4.92 (1.50)
2	2.20 (0.67)	2.20 (0.67)	6.89 (2.10)
2 1/2	3.28 (1.00)	3.28 (1.00)	8.20 (2.50)
3	3.94 (1.20)	3.94 (1.20)	10.20 (3.11)
4	4.27 (1.30)	4.27 (1.30)	13.39 (4.08)
5	5.51 (1.68)	5.51 (1.68)	16.80 (5.12)
6	6.56 (2.00)	6.56 (2.00)	20.21 (6.16)
8	8.86 (2.70)	8.86 (2.70)	26.90 (8.20)

Table 3-6: Equivalent length selector valves and monitored time delay valve

Designation	Connection type	Valve size (Inches)	Equivalent length [ft (m)]	Part no.
PR Selector valve 2"	NPT	2	2.005 (0.611)	24815
PR Lockout valve 2"	NPT	2	2.005 (0.611)	24768
CF Selector valve 1"	NPT	1	0.59 (0.18)	934713D
CF Lockout valve 1"	NPT	1	0.59 (0.18)	4005115D
CF Selector valve 1.5"	NPT	1.5	0.89 (0.27)	934714D
CF Lockout valve 1.5"	NPT	1.5	0.89 (0.27)	4005116D

Table 3-6: Equivalent length selector valves and monitored time delay valve

CF Selector valve 2"	NPT	2	1.21 (0.37)	934715D
CF Lockout valve 2"	NPT	2	1.21 (0.37)	4005117D
CF Selector valve 2.5"	NPT	2.5	1.41 (0.43)	934826D
CF Lockout valve 2.5"	NPT	2.5	1.41 (0.43)	4005082D
CF Selector valve 3"	NPT	3	1.80 (0.55)	934827D
CF Lockout valve 3"	NPT	3	1.80 (0.55)	4005083D
CF Selector valve 4"	NPT	4	2.20 (0.67)	934828D
CF Lockout valve 4"	NPT	4	2.20 (0.67)	4005084D

Table 3-7: Equivalent length container valves (combination: container valve, hose and check valve)

Designation	Connection type	Valve size	Equivalent length [ft (m)]	Part number
		Inches		
Quick release valve 200 bar (30L & 80L)	25E	0.5	2.13 (0.65)	4006190
				4006191
				4001024
				4001044

Table 3-7: Equivalent length container valves (combination: container valve, hose and check valve)

Quick release valve 300 bar (30L, 80L, & 140L)	25E	0.5	2.13 (0.65)	4006192
				4006193
				4001030
				4001034
				4001050
				4001054
*If ordering in Canada, add a "C" suffix to the end of a part number. For example, part number 4001024C represents a quick release valve 200 bar for Canadian markets.				

3.4 Protection Zone Seal Tightness

If the area of the protection zone is not completely sealed and vented according to the system calculations, the system may fail to reach a large enough concentration of extinguishing agent to put out the fire, or the demanded hold time may not be achieved or maintained. A visual, subjective assessment of the room seal tightness of the protection zone does not provide sufficient accuracy. Supplementary measures, like regular door fan tests, may be required. Refer to NFPA 2001 for more information.

The protection zone must also meet the following requirements:

- Doors and windows must be fitted with automatic closing devices where necessary.
- Windows must not open at all or only with special tools.
- Enclosing surfaces must consist of noncombustible material or material of low flammability.
- Fire protection sealing to protect neighboring zones from smoke or gases must be in place
- Enclosing surfaces and sealings must be designed for the overpressure that occurs during flooding.
- Pressure relief devices must be installed.
- There must be no non-lockable openings.

3.5 Door Fan Test

The door fan test is used to determine the integrity of the protection zone seal. With the aid of a fan mounted in the door, overpressure or under pressure is generated in the extinguishing zone. Based on multiple pressure differential and air throughput measurements, a leakage surface and the theoretical hold time of concentration capable of extinguishing fires can be calculated. In addition, any leakage can be localized for sealing measures.

A description of the door fan test is provided in the following regulations and standards:

- NFPA 2001
- ISO 14520-1

For proper use of the extinguishing system, adequate room permeability is a crucial factor.

3.6 Considerations for Air-conditioned Enclosures

Air conditioners generate a high air speed in operation. In the event of fire, this high air speed dilutes the fire smoke, which can delay detection of the fire. Early fire detection systems should therefore be used in air-conditioned rooms.

In air-conditioned enclosures that bring in outside fresh air, there is the danger that the fire smoke from outside will be suctioned in with the fresh air and the fire detection devices will respond incorrectly. The fresh-air supply should therefore be monitored with smoke detectors and automatically closed if fire smoke occurs.

i Volumes of air-conditioning or ventilation ducts that are in constant connection with the air volume of the flooding area must be taken into account as a supplemental volume in the quantity calculation of the extinguishing agent.

3.7 Requirements for Detectors and Control Panel

Fires must be detected reliably and at the earliest possible stage of a fire. Early fire detection is the basis for actuating the system at an early stage and therefore ensuring the lowest level of fire damage.

The components of the SRP must comply with the applicable local regulations.

- **i** UL Listed or FM Approved extinguishing system devices with an electric release require the use of a compatible UL Listed or FM Approved fire detection system/electric control device. Likewise, all fire detection devices must also be UL Listed or FM Accredited and compatible with the fire detection system/electric control device.

3.8 Pressure Relief Vent

An overpressure arises in the extinguishing zone during flooding. For the system to properly function and to avoid structural damage in the protected enclosure, the overpressure must be dissipated from the extinguishing zone via a pressure relief vent.

For details on the design of the pressure relief vent, see ISO 21805, NFPA 2001, and FSSA Pressure Vent Area Applications using Clean Agent Systems.

- **i** Door fan tests should be used to ensure venting equation accuracy.

- **i** The necessary duct cross sections can be pre-dimensioned using vInert or DesignManager. These values are only intended for a preliminary design of the pressure relief channel. They are not technically binding.

**CAUTION**

Risk of injury and property damage due to an incorrect design

During flooding, an incorrectly designed duct cross section may lead to parts of the building being destroyed. This can lead to injury and property damage.

- **For reasons of liability, have the calculation of the larger duct section performed by an engineering company that specializes in ventilation technology.**

3.9 Temperature-pressure Curves For Cylinders

The overpressure in the extinguishing agent container is based on the temperature. The figures below show the curves for the respective extinguishing agents.

i When designing the fire extinguishing system, the temperature of the protection zone and the storage location for the extinguishing agent containers must be taken into account.

Observe all regulations of any applicable guidelines.

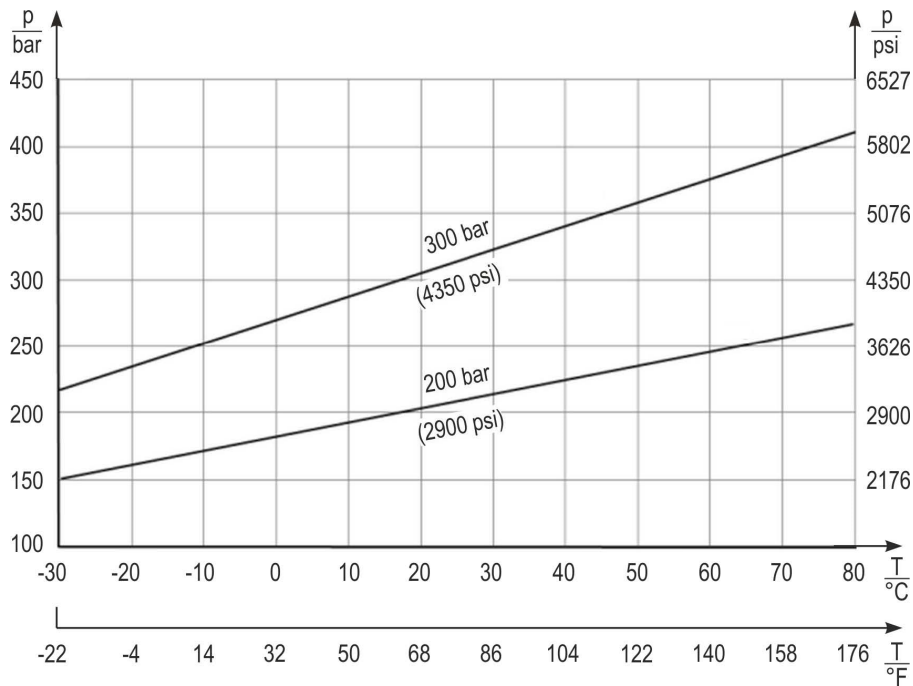

Figure 3.1: Temperature/pressure curve for IG-100 (nitrogen) in the 2901psi and 4351psi system (200 bar and 300 bar system)

- p :Pressure
- T :Temperature

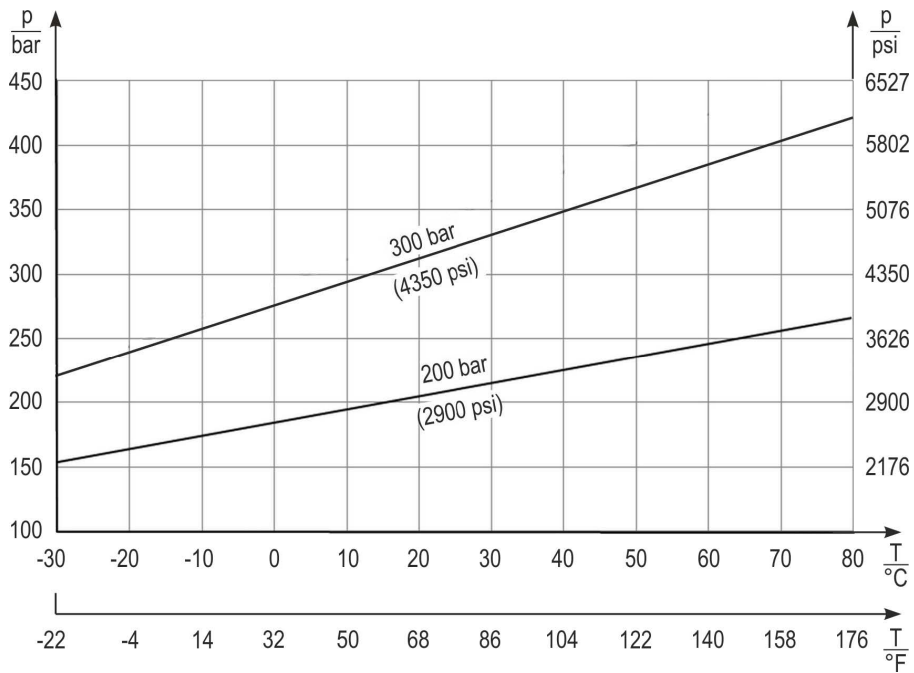

Figure 3.2: Temperature/pressure curve for IG-01 (argon) in the 2901psi and 4351psi system (200 bar and 300 bar system)

- p :Pressure
- T :Temperature

4 Transport, Packaging and Storage

4.1 Eccentric Center of Gravity

WARNING

Risk of injury due to falling or tilting packages

Packages can have an eccentric center of gravity. If attached incorrectly, the package can tip over and fall. Severe injuries or even death can result by falling or tipping packages.

- When transporting with a crane, attach the crane hook in such a manner that it is above the package's center of gravity.
- Carefully lift the package and see whether it tips. If necessary, change the attachment.

4.2 Improper Transport of Hazardous Goods

WARNING

Life-threatening danger due to improper transport of hazardous goods

The extinguishing containers are hazardous goods if they contain residual quantities of extinguishing agents, e.g. after a release. If extinguishing agent containers are damaged due to improper transport, severe to fatal injuries can occur.

- Always transport extinguishing agent containers in compliance with the instructions contained in this manual.
- Comply with local regulations concerning transport of hazardous goods.
- Only remove protective valve caps of the extinguishing agent containers after they have been mounted at the installation site; reattach the protective valve caps prior to every transport.
- Comply with additional instructions on the extinguishing agent containers.

NOTICE**Material damage due to improper transport**

Improper transport may cause transported items to fall down or topple over. This may cause significant and costly material damage.

- Ensure all regulations are followed during transport and shipping.
- Only use the designated attachment points.
- Only remove packaging immediately prior to installation.

4.3 Transport Inspection

1. Check all system parts for completeness or transport damage immediately upon receipt.
2. Check the fill quantity of the extinguishing agent container.
3. If there is apparent external transport damage or if an extinguishing agent container does not have the specified fill quantity, proceed as follows:
 - Do not accept the delivery or only accept the delivery with reservation.
 - Note the scope of the damage on the transport documents or on the freight forwarder's delivery ticket.
 - Initiate a complaint procedure.

i Report every complaint as soon as it is detected. Claims for damage compensation can only be considered within the applicable period specified for the reporting of complaints.

4.4 Transport

4.4.1 Transporting extinguishing agent cylinders

Personnel:

- Installing contractor

WARNING

Danger to life due to extinguishing agent escaping in an uncontrolled manner.

The extinguishing agent cylinders are pressurized. If they are damaged, extinguishing agent may escape in an uncontrolled manner. This may cause the cylinders to slide around uncontrollably and cause serious injuries. Escaping extinguishing agent can also result in frostbite and life-threatening injuries to the skin and eyes.

- Damaged cylinders should not be transported under pressure and should instead be emptied before transport.
- Do not transport cylinders until the transportation cap and the outlet venting safety plug are in place.

WARNING

Risk of injury due to improper transport of heavy cylinder.

If heavy cylinders are transported incorrectly, dangerous injuries may be caused, e.g. crushing or injuries to the spine.

- On the construction site, only transport cylinders using suitable transport methods.

WARNING**Risk of injury due to tipping cylinders**

Cylinders are heavy and may have a high center of gravity depending on the design. If cylinders tip while being handled, this can lead to severe injuries or even death.

- Transport cylinders in such a way that they cannot tip.
- Fasten extinguishing agent containers to a wall or other part of the building with a clamp immediately after transport.

4.4.2 Transporting filled cylinders

Filled cylinders are dangerous goods of class 2.2 (non-ignitable, non-toxic gases). The cylinders must thus be transported in accordance with the local regulations for the transport of dangerous goods.

1. Contact the local specialist for the transport of dangerous goods and inquire about the regulations on transporting cylinders.



Figure 4.1: Valve

2. Make sure that all safety plugs on the cylinder valve are attached.



Figure 4.2: Valve protection cap

3. Screw on the valve protection cap to the extinguishing agent container.



Figure 4.3: Hazard label

4. Check that the dangerous goods label (UN number and name) is present.
5. Fasten the extinguishing agent containers standing up in a suitable transport frame and secure against sliding.
6. Transport the pallets in accordance with the specifications in this instruction.

4.4.3 Transporting empty extinguishing agent containers

Extinguishing agent containers that have been activated contain a residual pressure of approx. 22 psi (1.5 bar). This residual pressure prevents dirt and moisture entering the container via the valve outlet.

Depending on the local regulations, this container may or may not represent a dangerous good and may be subject to the regulations for transporting dangerous goods.

Contact the local specialist for the transport of dangerous goods and inquire about the regulations on transporting activated extinguishing agent containers.

4.4.4 Emptying extinguishing agent containers



Empty containers are also considered dangerous goods.

Observe the instructions on transporting empty extinguishing agent containers.

Cylinders with obvious damage or with corrosion in the base area must not be re-used. They must be emptied before transportation and then disposed of. Use the following procedure to correctly empty a cylinder.



Cylinders must be secured before they are emptied.

1. Unscrew the valve protection cap from the extinguishing agent container.
2. Relieve the pressure via the pressure gauge connection.
3. Screw the valve protection cap onto the extinguishing agent container.

4.4.5 Transporting pallets

Transporting pallets with the fork lift

Personnel:

- Installing contractor

Transport packages that are attached to pallets can be transported with a forklift under the following conditions:

- The forklift must be configured appropriately for the weight of the transport cases.
- The transport package must be securely fastened on the pallet.

Transportation Instructions

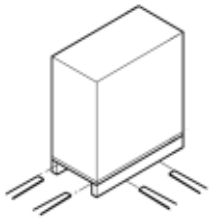

Figure 4.4: Transport with the forklift

1. Drive the forklift with the forks between or under the spars of the pallets.
2. Drive in the forks until they protrude on the opposite side.
3. If there is an eccentric center of gravity, ensure that the pallet cannot tilt.
4. Lift the pallet with the transport package and transport to desired destination.

4.5 Packaging

4.5.1 About the packaging

The individual packages are packed in boxes or crates in accordance with the expected transport conditions.

The packaging should protect the individual components from transport damage and other damage until the components are assembled. Consequently do not destroy the packaging and only remove when necessary until the assembly is complete.

4.5.2 Handling packaging materials

Dispose of packaging materials in accordance with the appropriate statutory regulations and local guidelines.

NOTICE**Improper disposal poses an environmental hazard**

Packaging materials are valuable raw materials and in many cases, they can be reused or recycled. Improper disposal of packaging materials causes environmental hazards.

- **Dispose of packaging materials in an environmentally responsible manner.**
- **Comply with locally applicable disposal guidelines. If necessary, commission a specialized company to dispose of packaging.**

4.6 Storage

4.6.1 Storing extinguishing agent containers

Store extra extinguishing agent cylinders under the following conditions:

- Do not store outdoors.
- Store in a dry, dust-free environment.
- Do not expose to aggressive media.
- Protect against direct exposure to sunlight.
- Avoid mechanical vibrations/shocks.
- Avoid condensation moisture.
- Storage temperature: compliant with “Operating conditions” on page 37
- Store with the valve protection cap and outlet venting safety plug in place.
- Always store in the supplied transport frame or lying on the supplied pallet.
- Observe national regulations on the storage of extinguishing agent cylinders.
- If stored for more than 3 months, regularly check the general condition of all extinguishing agent cylinders. If necessary, contact an installing contractor or authorized service personnel and have damaged or corroded extinguishing agent containers replaced. Contact Viking Technical Services if possible.

WARNING

Risk of injury from illegible symbols

Over time, labels and signs can become dirty or illegible. Risks that pertain to illegible signage can no longer be recognized and necessary operating instructions can no longer be adhered to. This will lead to risk of injury.

- Keep all safety, warning and operating instructions easily legible at all times.
- Replace any damaged signs or labels immediately.



There may be additional storage notices on the packaging items that go beyond the requirements stipulated here. Observe them accordingly.

4.6.2 Storing packages

Only store packages under the following conditions:

- Do not store outdoors.
- Store in a dry area.
- Do not expose to abrasive media.
- Protect from direct sunlight.
- Avoid mechanical vibration.



It may be that storage instructions are affixed to the packages that extend beyond the requirements cited here. Follow these additional instructions accordingly.

5 Design of Inert Gas Extinguishing Systems

5.1 Project Procedure

A sample project sequence for inert gas extinguishing systems is outlined below. Activities affecting the planning and installation of the fire detection and electrical control system are not listed.

Table 5-1: Project procedure

Number	Project step
1	Check whether all the required information from the beginning of the design phase until transfer to the operator is present
2	Calculate the protection volumes and estimate the quantity of extinguishing agent
3	Determine the system pressure, size, and number of extinguishing agent containers
4	Determine the location of the cylinders and define the arrangement of the cylinder battery
5	Determine the pipeline routing and prepare isometric drawings
6	Calculate the system with the calculation program Oxexo vInert or DesignManager
7	Optimize the system with the aid of the calculation results if need be
8	Have the extinguishing agent container set-up and the pipeline routing approved by the operator
9	Order system components
10	Assemble the system
11	Check the system calculation against the actual pipeline routing, which may deviate from the plan
12	Prepare documentation and transfer it to the operator

5.2 Determining Extinguishing Agent Quantity

The filling quantity for an inert gas extinguishing system is determined by NFPA 2001. Design concentrations found within NFPA 2001 may differ with the design concentrations of your system.

For design concentrations specific to the system, See “Design concentration data” on page 165.

5.3 System Piping Design

The system design may only be carried out by using a calculation program approved by the supplier of the system. vInert or DesignManager must be used for the system design calculation.

5.3.1 System piping design (Pressure reducing system)

If using a CF system, refer to “System piping design (Constant flow system)” on page 62.

The system piping of PR inert gas extinguishing systems is divided into high-pressure and low pressure system piping:

- High-pressure system piping: The high-pressure system piping zone begins at the manifold and ends at the pressure reducer.

Depending on the system, the high-pressure system piping must be designed for a pressure of at least 2901psi or 4351psi (200 bar or 300 bar).

- Low pressure system piping: The low pressure system piping zone begins behind the pressure reducer and ends at the nozzles.

The low pressure system piping must be designed for a pressure of at least 870 psi (60 bar).

Rules for designing pipeline:

- To ensure that the nozzles do not become blocked, “blind” pipe sections with a length of approximately 8 in. (0.2 m) should be positioned at the end of each pipe branch so that particles (rust film, metal chips, and so on) can accumulate in them while the extinguishing agent flows out.
- Changes in direction can be made at any distance from each other.
- T-branches can be arranged at any distance from each other.
- Nozzle branches can be arranged freely if existing regulations for the arrangement and orientation of the nozzle used are observed.

5.3.2 System piping design (Constant flow system)

If using a PR system, refer to “System piping design (Pressure reducing system)” on page 61.

There is no distinction between high-pressure system piping and low pressure system piping in CF system piping. All system piping in CF inert gas extinguishing systems must be designed for a pressure of at least 870 psi (60 bar).

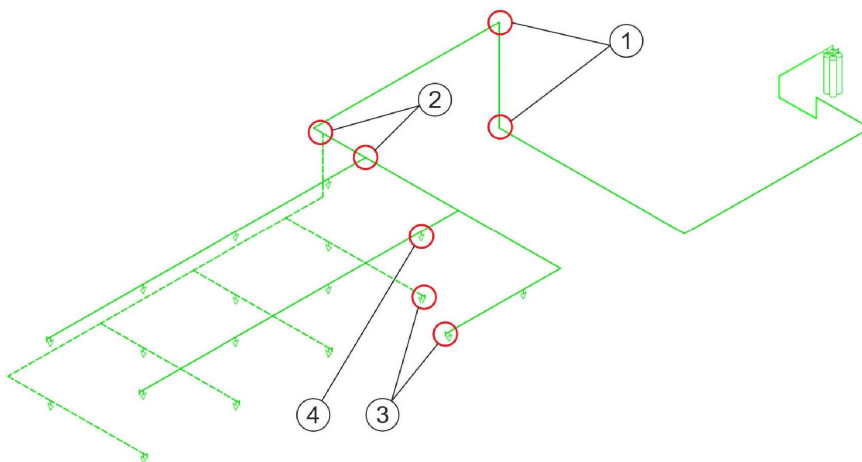

Figure 5.1: Typical system piping for an inert gas extinguishing system

1. Shift in direction
2. T-branch
3. “Blind” pipe sections
4. Nozzle

5.3.3 Nozzle arrangement

For the nozzle arrangement, note the following:

- Arrange the nozzles with approved specifications.
- Arrange the nozzles to ensure an even distribution of the extinguishing agent throughout the extinguishing zone.
- Arrange the nozzles in a way that ensures that sensitive devices (e.g. control cabinets) are not damaged by the nozzle jet and that their function is not impaired.

5.3.4 Dimensioning of the system piping, nozzles, and pressure relief vent

The dimensioning of the system piping, nozzles and pressure relief vent must be carried out using a design program that has been approved with the system.

5.3.5 System piping design with full calculation using the vInert or DesignManager programs

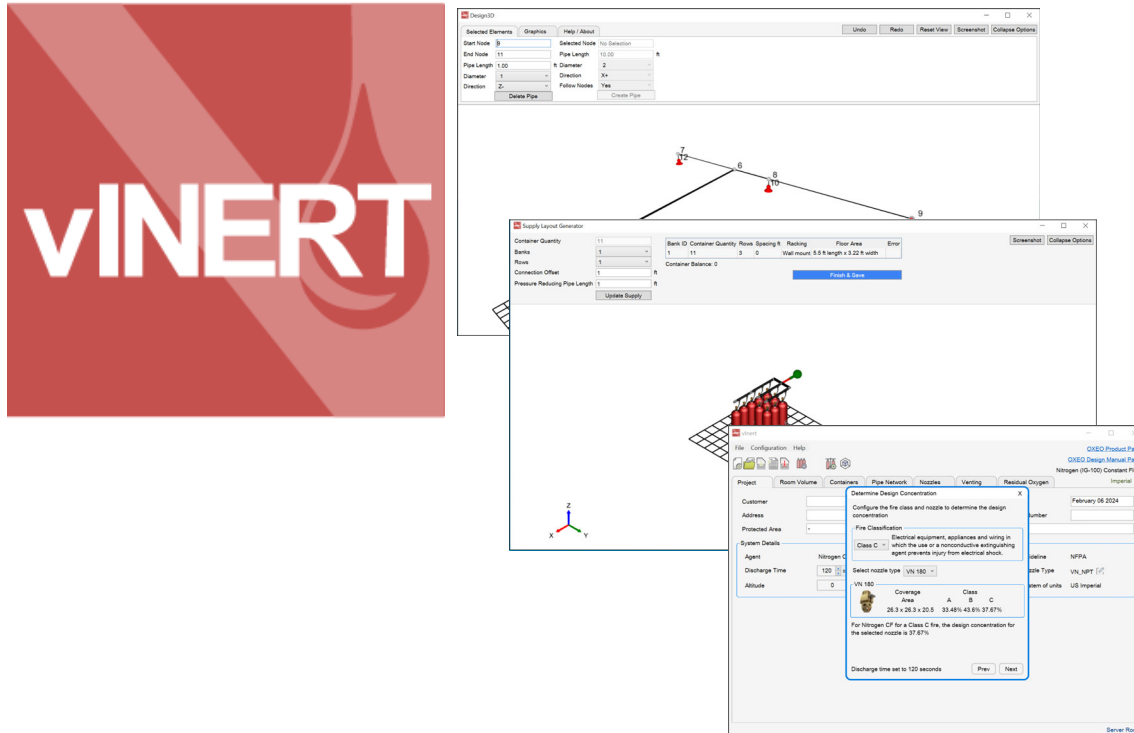

Figure 5.2: vInert

The system piping for extinguishing agent flooding is designed using a calculation program (vInert or DesignManager) specifically developed by the manufacturer for the design of fire extinguishing systems.

The vInert or DesignManager calculation programs must be used only after the appropriate training has been provided by the manufacturer.

5.4 Post-discharge Venting Requirements



DANGER

Risk of suffocation due to lack of oxygen

System discharge will flood the protected area with extinguishing agent which creates a hazardous atmosphere.

- **The protected area must be sufficiently vented after system discharge to replenish oxygen levels.**

Consider natural or forced extraction systems to ventilate the protected area and replenish oxygen levels after system discharge.

6 Assembly and Installation

6.1 Introduction

This chapter is intended for expert installation personnel who are familiar with the handling of the fire extinguishing systems described herein.

NOTICE

The racking and support structure for your system is a crucial component and must be assembled prior to cylinder and manifold connections. Refer to “Appendix B - Racking Assembly” on page 223.

6.2 Warnings for Assembly and Installation



WARNING

Risk of injury from faulty release

A faulty release of the system may cause severe injuries including death and significant property damage.

- Protect against accidental discharge during installation.
- Do not install electrical release solenoids on any cylinders until instructed to do so.
- Keep the pneumatic connection of the pilot cylinder unattached until testing is complete.

**WARNING****Risk of injury due to improper installation**

Improper installation can lead to severe injuries or even death as well as significant property damage.

- Prior to starting tasks, ensure that there is adequate free space for installation.
- Always handle open, sharp-edged components carefully.
- Always keep the installation area clean. Parts and tools that are lying loose or on top of each other create hazards.
- Install components as instructed in this manual.
- Follow all listed torque values.

**WARNING****Risk of injury due to escaping extinguishing agent**

If the system is unintentionally activated during the course of assembly, extinguishing agent can escape uncontrollably. This may lead to severe injuries or even death, as well as significant property damage.

- Remove all safety pins on components of the system only after complete assembly of the components.
- Do not remove the outlet venting safety plug or shipping cap until instructed to do so.
- Only mount release devices when the extinguishing agent containers have been connected to the system piping.
- Always protect the cylinders from tipping over.
- If there is an accidental discharge, exit the extinguishing zone immediately.
- Verify that personnel are trained as instructed to handle an accidental discharge.

**WARNING****Danger due to contamination**

Contaminated pneumatic pilot lines or pipes can cause individual components to malfunction and thus also cause the whole system to malfunction. This can cause serious injury or even death, and may also cause substantial property damage.

- Before assembly, check all pneumatic pilot lines and pipes for contamination (e.g. particles or grease) and clean if necessary.

**WARNING****Danger due to the usage of unsuitable components**

If unsuitable, defective, or contaminated components are mounted, functionality of the system can be impaired. This can lead to severe injuries or even death, as well as significant property damage.

- Only use undamaged and clean components.
- Do not use any components that do not correspond to the design data or do not fit.
- If in doubt, contact the manufacturer.

NOTICE**Material damage due to insufficient load-bearing capacity**

If system components are fastened to building components that do not have sufficient load-bearing capacity, they can fail in operation and damage the system.

- Only fasten components on building parts (e.g. walls) that have adequate load-bearing capacity and that can withstand the anticipated loads.
- Only use fastening elements with sufficient bearing capacity.

6.3 Requirements Imposed on the System Piping



WARNING

Risk of death due to improper pipe mounting

If components leak or fail due to improper pipe mounting, this can cause failure of the system. If there is fire, life-threatening danger as well as significant material damage can occur.

- Fit pipes stress-free before mounting. The cap nut of the pipe connection must screw on easily across the entire thread length.
- Avoid vibrations by using suitable pipe holders rated for local regulations.



WARNING

Danger of injury due to an unsuitable system piping

If the system piping is not correctly configured or properly installed, functionality of the system can be restricted and cause the system piping to fail.

- Hydraulically calculate the layout of pipes.
- For PR systems, design and mount the system piping up to the pressure reducer according to locally valid provisions for systems with an operating pressure according to the system pressure [2901 psi (200 bar) at 59°F (15°C) or 4351 psi (300 bar) at 59°F (15°C)].
- Design and install system piping behind the pressure reducer (or for the entirety of the system piping in CF systems) in accordance with the locally valid regulations for fire extinguishing systems with an operating pressure of 870 psi (60 bar).
- Do not retroactively change the pipe routing or cross sections.
- Always execute a new calculation if there are planned changes.
- Comply with all the requirements imposed on pipes cited below.

Pipes, fittings and fasteners are part of the system piping. The manufacturer does not lay out the system piping. It must be individually executed by the installing contractor in accordance with local regulations.

The system components fit the piping components that are offered by the manufacturer. If piping components other than those offered by the manufacturer are used, these must be selected, installed, and connected in accordance with locally valid regulations.



The system piping must be installed in accordance with the design data created by vInert or DesignManager before the system components are installed.

6.3.1 Design criteria

Always comply with the following when designing the system piping:

- The system piping must be able to withstand the required system pressures. Take pressure hammers into account.
- Select materials and diameters of pipes in accordance with ISO 14520, NFPA 2001, FSSA Pipe Design Handbook, and any other locally applicable regulations. Special attention must be paid to the compressive strength.
- Install system piping in accordance with the hydraulic calculation.
- Heed recoil due to discharge nozzles.
- Avoid unnecessary angles.
- Clean the system piping in the course of installation.
- Protect the system piping against corrosion.
- Seal the system piping with a suitable, locally approved and recognized sealant.
- Provide equipotent bonding.
- Do not suspend objects from pipes.



Structural changes of the protected enclosure require a new design of the entire system including the system piping.

6.3.2 Old pipes

Personnel:

- Installing contractor

NOTICE

Material damage due to unsuitable pipes

If pipes do not satisfy the requirements, there is a danger that they will fail upon system activation.

- **Only use pipes that can withstand the required pressures.**

If old pipes are used in the system, or if existing pipes are used in the protected area, they must be checked before they are used.

1. Pressure test the pipes.
2. Empty pipes.
3. Clean the pipes.
4. Let the pipes dry.

6.4 Manifold Assembly

Personnel:

- Installing contractor

Protective equipment:

- Safety gloves
- Safety footwear

Dimensioning of the manifold is primarily based on the hydraulic calculation.



During the assembly of the manifold, pay attention to whether it is for a one-, two-, or multiple-row extinguishing cylinder set-up.

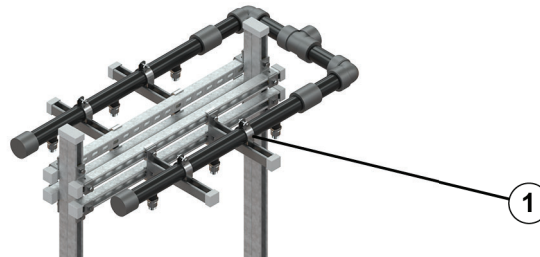

Figure 6.1: Manifold assembly

1	Bracket
---	---------

1. Install the racking assembly brackets and cut an appropriate length of rubber. See “Appendix B - Racking Assembly” on page 223.
2. Open the bracket by unscrewing the bolt connecting the two components.
3. Wrap the cut rubber around the location of the manifold that will rest against the brackets.
4. Place the manifold into the brackets.
5. Close the brackets around the manifold and secure with the bolt.

6.5 System Assembly - Extinguishing Agent Containers

Personnel:

- Installing contractor

Protective equipment:

- Safety gloves
- Safety footwear



DANGER

Risk of accidents due to heavy pressurized containers.

Extinguishing agent containers are very heavy and may be pressurized. If handled improperly, they can pose a life-threatening hazard.

- **Always handle extinguishing agent containers with at least 2 people.**
- **Always use suitable means of transport.**
- **In the meantime, or as soon as possible, secure the valve outlet with an outlet venting safety plug and the valve with a protective valve cap.**
- **Wear safety gloves, safety footwear, protective goggles and hearing protection.**

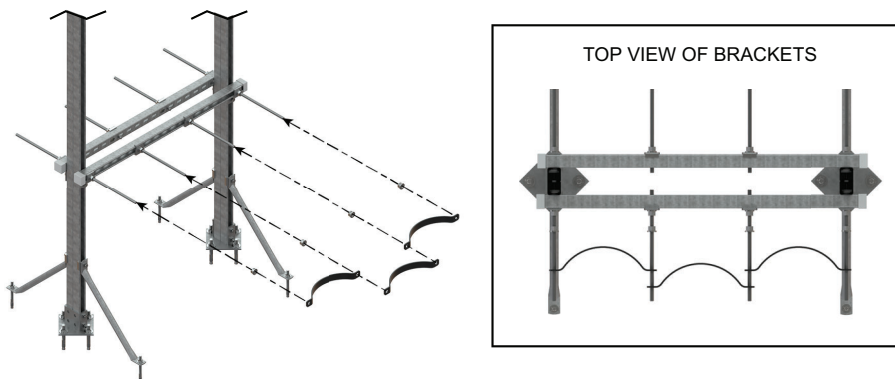

Figure 6.2: Manifold bracket arrangement

1. Arrange the manifold brackets onto the steel rod as shown in Figure 6.2 .



Figure 6.3: Position extinguishing agent cylinders

2. Carefully place the extinguishing agent containers in position on the manifold.

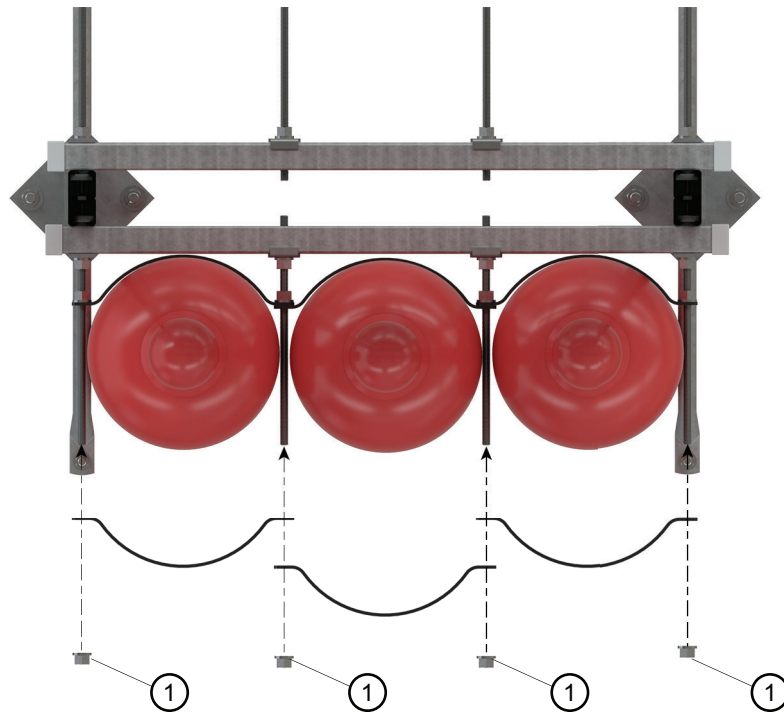

Figure 6.4: Properly arrange manifold brackets around cylinders

3. Loosely install the front manifold brackets and secure them with the nuts (1).



Screw in the mounting brackets until the extinguishing agent container CANNOT fall but can still be adjusted.



Verify cylinder labels are NOT obstructed by the cylinder bracket. Refer to “Appendix B - Racking Assembly” on page 223 for more information.



Figure 6.5: Remove caps

4. Remove caps from cylinders.



Figure 6.6: Align valve with manifold

5. Align cylinder valve with manifold



Figure 6.7: Tighten brackets

- | | |
|---|-----|
| 1 | Nut |
|---|-----|

6. Tighten the brackets around the cylinder until cylinder is firmly secure.
7. Repeat steps 1-6 for 2 additional rows, if necessary.
8. Repeat steps 1-7 for additional manifolds, if necessary.

6.6 Mounting the Supervised Pressure Gauge



Only pressure gauges/supervised pressure gauges suitable for this valve type may be used.

The quick release valve has a non-return valve on the pressure gauge connection so that the pressure gauge/supervised pressure gauge can also be assembled if the extinguishing agent container is pressurized.

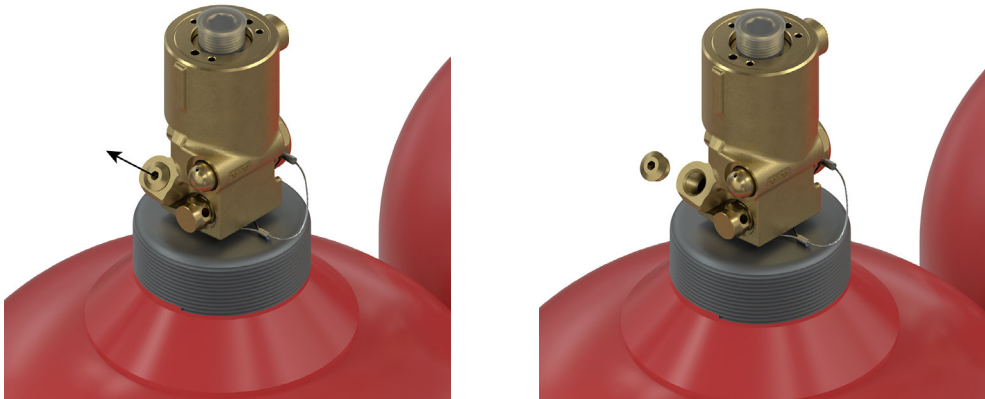

Figure 6.8: Removing the gauge cap

1. Remove the gauge cap from the gauge connection.

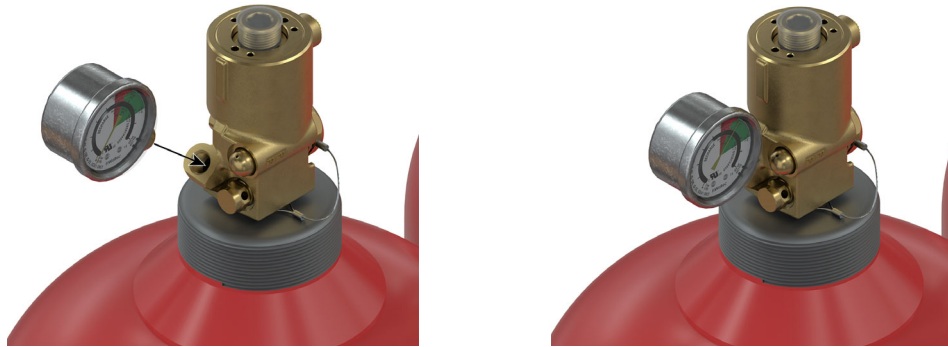

Figure 6.9: Inserting the pressure gauge



WARNING

Risk of injury due to escaping high pressure gases. Adding thread tape to the gauge threads will prevent a proper seal between the tank valve and the gauge.

- Do not apply thread tape to the gauge threads.

2. Insert the pressure gauge into the gauge connection.

NOTICE

- Gauges should only be assembled hand tight.
- Do not apply any torque to the gauge.

3. Tighten until the gauge gives a pressure reading.



To align, the supervised pressure gauge can be turned back by a maximum of 3/4 rotation.

6.7 Installing the Discharge Hose

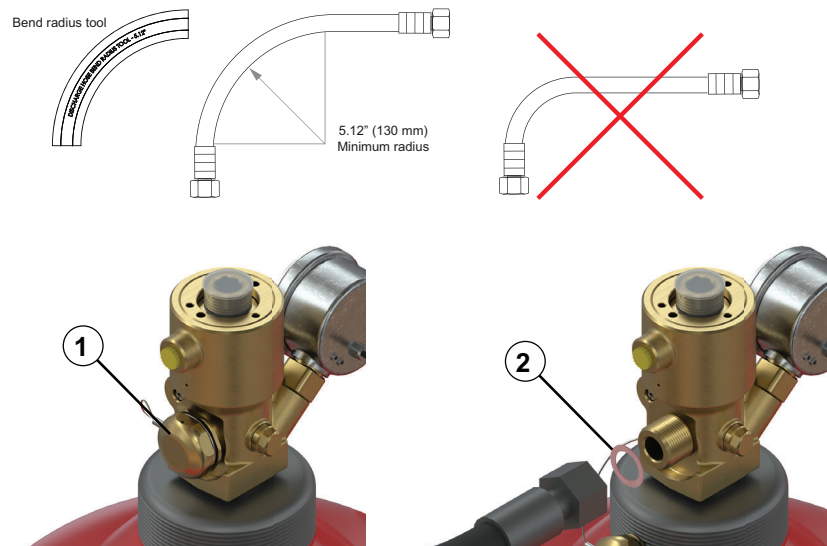

Figure 6.10: Installing the hose onto the cylinder valve

1. Remove the venting safety plug (1).

WARNING Risk of injury or product damage due to escaping high pressure gas. Applying thread tape to the valve will prevent a proper seal between the valve and the discharge hose.

- Do not apply thread tape to the valve threads.
 - Tighten the hose to a torque of 40.16 ± 3.7 ft-lb
 - Do not bend the hose less than its **MINIMUM** radius of 5.12 inches (130 mm). Refer to Figure 6.10
 - Use the bend radius tool 26412 to ensure proper installation.
2. Insert a gasket (2) into an end of the hose.
 3. Screw the hose union onto the hose connection. Tighten the hose to a torque of 40.16 ± 3.7 ft-lb.

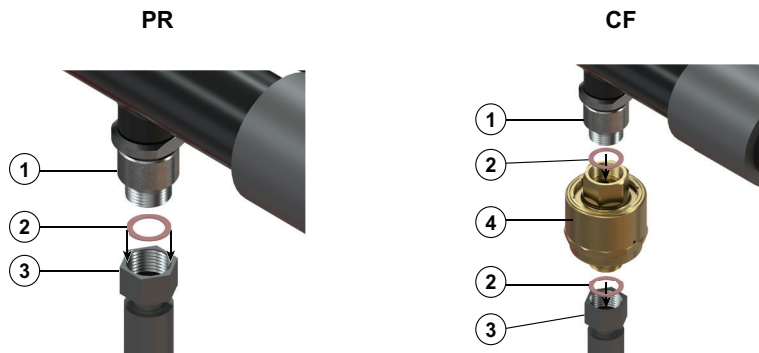

Figure 6.11: Installing the hose and/or regulator onto the manifold

1	Check valve	3	Hose (union)
2	Gasket	4	Pressure regulator

4. Insert a gasket (2) into the other end of the hose (3) for PR systems, or into the hose and regulator for CF systems.

WARNING Risk of injury or product damage due to escaping high pressure gas. Applying thread tape to the valve will prevent a proper seal between the valve and the discharge hose.

- Do not apply thread tape to the valve threads.
 - Tighten the hose to a torque of 40.16 ± 3.7 ft-lb
 - Do not bend the hose less than its **MINIMUM** radius of 5.12 inches (130 mm). Refer to Figure 6.10 on page 80.
 - Use the bend radius tool 26412 to ensure proper installation.
 - Do not apply torsion to the hose.
 - Use the bend radius tool 26412 to ensure proper installation.
5. For PR only, screw the hose union (3) onto the preinstalled manifold check valve (1) to a torque of 40.16 ± 3.7 ft-lb. This concludes the procedure for the PR system.
 6. For CF only, install the pressure regulator (4) between the hose (3) and the check valve (1) as shown in Figure 6.11 .
 7. Check that the hose, manifold, and valve outlet are correctly aligned with one another.
 8. Firmly tighten both hose union nuts to a torque of 40.16 ± 3.7 ft-lb.

6.8 Fitting Modification

Some of the fittings that come with the system need to be modified (extra pieces removed) before installation. Refer to the following images for reference on each component before proceeding to the installation instructions.

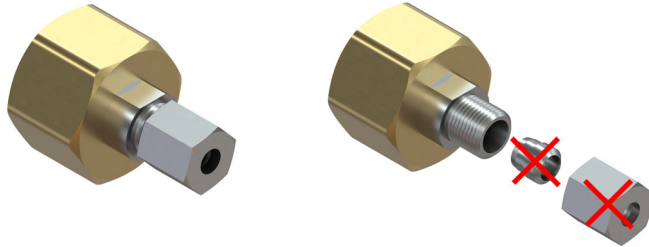

Figure 6.12: F W21 8 BSPP x M 6 mm M12



Figure 6.13: M 1/4 BSPP x M 6 mm M12

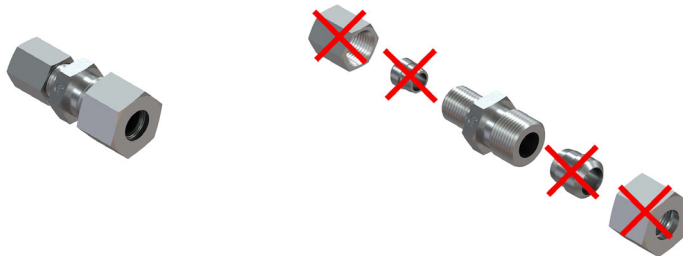

Figure 6.14: M 10 mm M16 x M 6 mm M12



Figure 6.15: M G1/8 x F M12X1

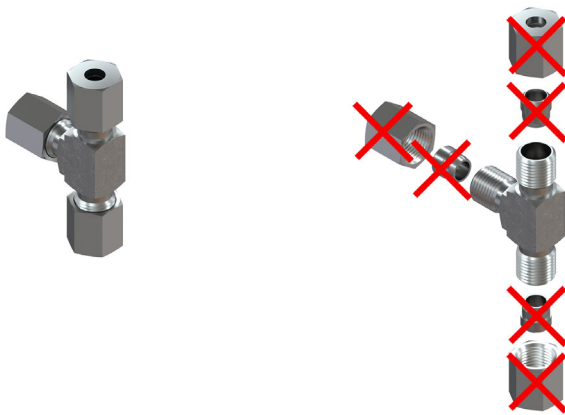

Figure 6.16: Tee M 6 mm x M 6 mm x M 6 mm 3 x M12

6.9 Installing the Pilot Hose

WARNING Risk of injury or product damage due to escaping high pressure gas.

- Do not apply thread tape or sealant to the threads of any pilot system connections unless otherwise noted.
- Assemble all threaded connections hand-tight plus a 1/4 turn.

NOTICE

- The following section pertains to systems that do NOT require additional occupiable space protection, according to NFPA 2001.
- For systems that do not require additional occupiable space protection per NFPA 2001, skip to “Occupiable Space Kit” section on page 93.

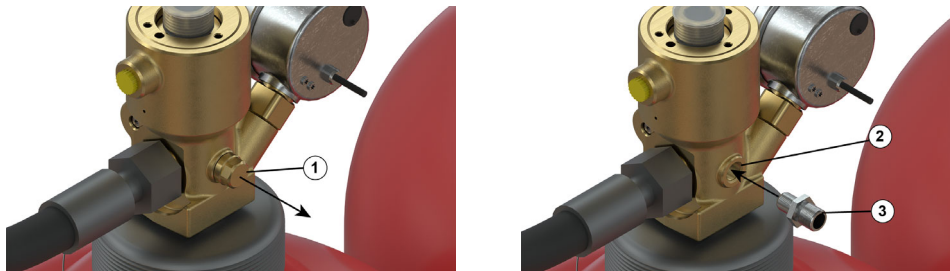

Figure 6.17: Remove pilot line plug and install fitting on the primary cylinder

1	Pilot line plug
2	Pilot line connection
3	Fitting

WARNING Risk due to contamination.

- Before assembly, check the pneumatic pilot lines for contamination and clean them if necessary.
1. Remove the plug from the pilot line output connection and install the fitting.

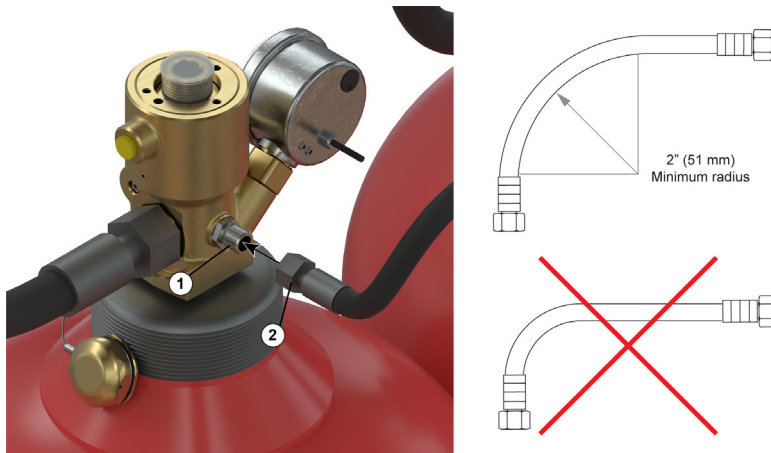

Figure 6.18: Install the pilot line

WARNING Risk of injury or product damage due to escaping high pressure gas. Applying thread tape to the valve will prevent a proper seal between the valve and the discharge hose.

- Do not apply thread tape to the valve threads.
- Tighten the hose to a torque of 40.16 ± 3.7 ft-lb
- Do not bend the hose less than its **MINIMUM** radius of 5.12 inches (130 mm). Refer to Figure 6.10
- Use the bend radius tool 26412 to ensure proper installation.

2. Install the pilot line to the fitting.

4	Fitting
5	Pilot line



WARNING

Risk of injury or product damage due to escaping high pressure gas. Applying thread tape to the valve will prevent a proper seal between the valve and the pilot line hose.

- Do not apply thread tape to the valve threads.
- Tighten the hose 1/4 turn (90 degrees) past hand-tight.
- Do not bend the hose less than its **MINIMUM** radius of 2 inches (51 mm).



The pilot hoses are to be installed hand tight, then 1 to 1.5 additional turns with a suitable tool.

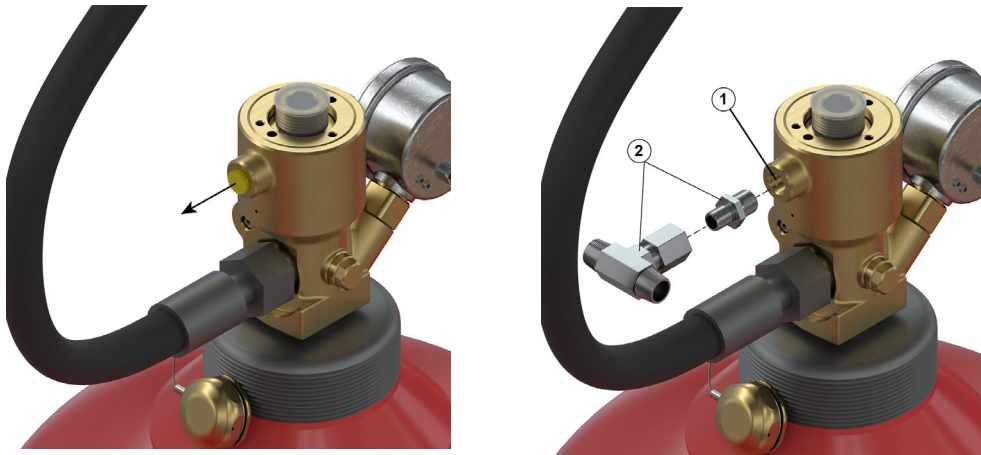

Figure 6.19: Remove the yellow cap and install the pilot fittings onto the secondary cylinder(s)

1. Remove the yellow cap from the pilot line input on all secondary cylinders.
2. Install the tee fittings onto the pilot line input connections.

1	Pilot line input connection
2	Tee fittings

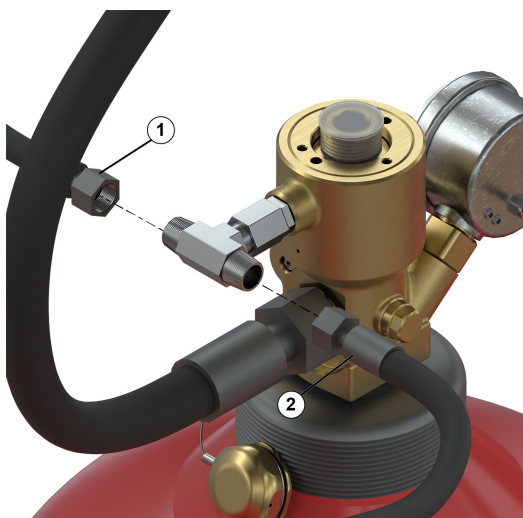

Figure 6.20: Install the pilot hoses between the cylinders

- | | |
|---|------------------------|
| 1 | To next cylinder |
| 2 | From previous cylinder |

3. Install the pilot hose from the primary cylinder to the secondary cylinder pilot input.
4. Install the pilot hose from the tee fitting to the next secondary cylinder pilot input.

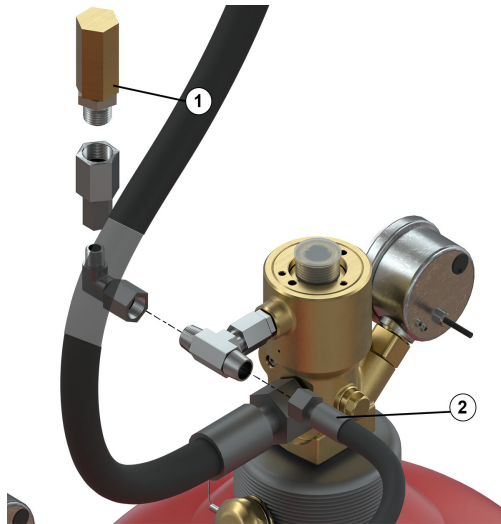

Figure 6.21: Install the relief device

- | | |
|---|------------------------|
| 1 | Relief device |
| 2 | From previous cylinder |

5. Install the relief device onto the tee connection of the last secondary cylinder.

NOTICE

Property damage due to incorrect assembly

Integrate the relief device upright at all times into the pilot line. Install the safety device as close as possible to a point of possible leakage (e.g. control gas container).



WARNING

Risk of injury due to incorrect installation

- Make sure that the relief device is positioned vertically pointing upward.

6.10 Installing the Releasing Solenoid to the Primary Valve



Figure 6.22: Install releasing solenoid to primary valve



DANGER

Risk of death due to accidental discharge.
Installing the releasing solenoid with the release pin in the activated position can result in accidental discharge.

- Verify that the release pin is in the not activated position.



DANGER

Risk of death due to accidental discharge.
Over-tightening the solenoid can result in accidental discharge.

- Tighten the solenoid to a maximum torque of 18.44 ± 2.95 ft-lb.

1. Install the releasing solenoid to the primary cylinder valve to a torque of 18.44 ± 2.95 ft-lb.

**WARNING**

Risk of injury due to escaping extinguishing agent.

Assembly of the release device with a release pin in the activated position causes the quick release valve to open immediately. This results in a risk of serious injury and substantial property damage.

- Before assembling the release device, you must ensure that the release pin is in the not activated position.
- Before assembling the release device, you must ensure that the extinguishing agent cylinder is securely fastened and that the extinguishing agent line is connected to the valve output.
- Immediately vacate the suppression zone in case of faulty release.
- Inform all persons working in the installation zone about the risk of faulty release.



For assembly, only use the intended wrench flat and a suitable tool, for example, a torque wrench.

Observe the documentation of the release device.



Figure 6.23: Monitor device

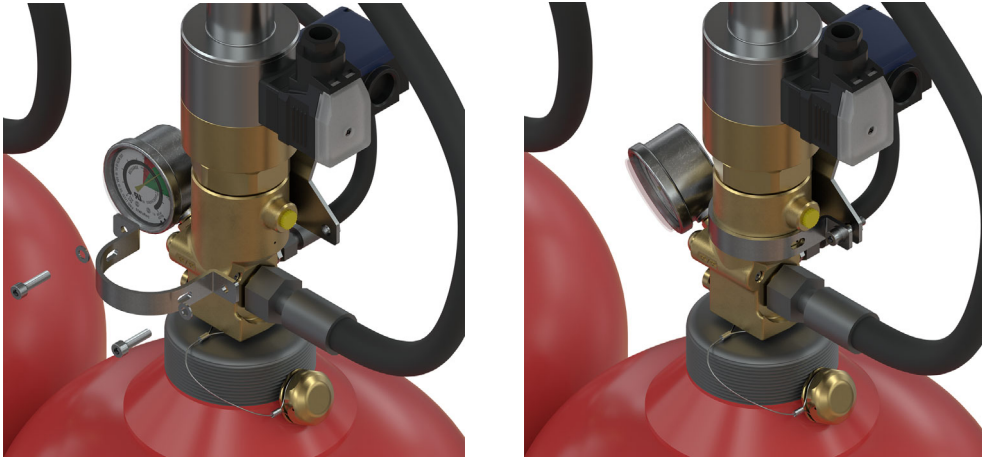

Figure 6.24: Install the monitor switch

2. Install the monitor switch to the releasing solenoid.



WARNING

Danger due to incorrectly assembled pipe clamp.

- Make sure that the pressure relief bore of the valve is visible through the extended hole of the pipe clamp.

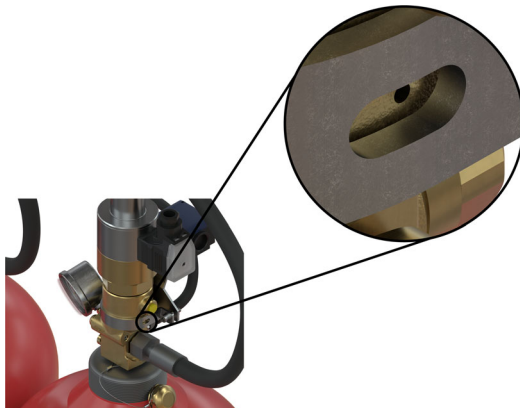

Figure 6.25: Proper monitor positioning

6.11 Occupiable Space Kit

This section ONLY pertains to installations that require additional occupiable space protection per NFPA 2001. If the installation does not require additional occupiable space protection, skip to section “Installing the Manifold Relief Valve and Lockout Valves” on page 109.

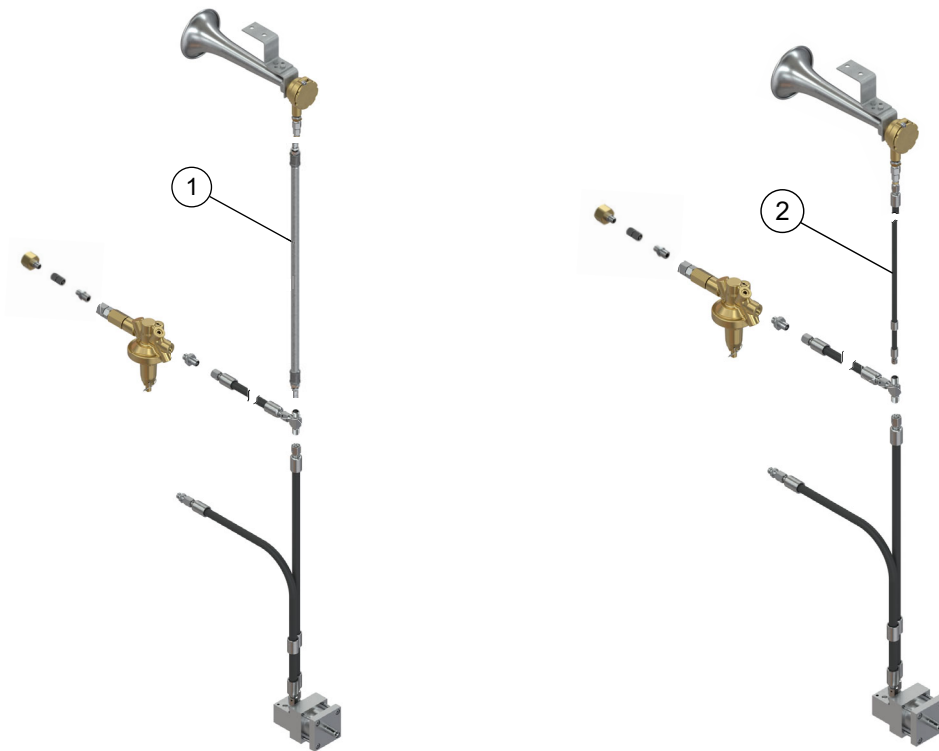

Figure 6.26: Occupiable space kit

- | | |
|---|---------------------|
| 1 | Hard pipe assembly |
| 2 | Pilot line assembly |

6.11.1 Installing the occupiable space kit

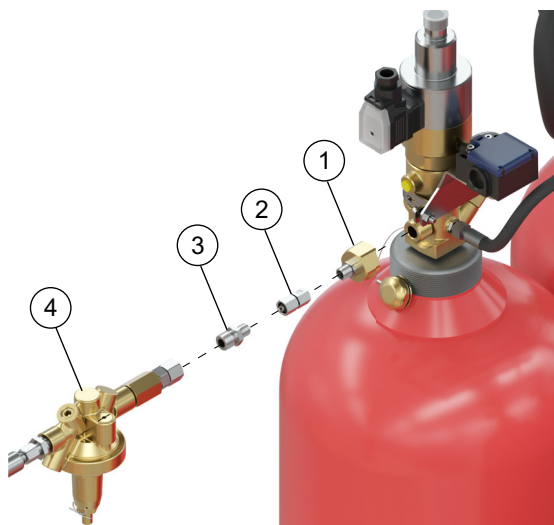

Figure 6.27: Assembling the pilot tank connection

1	Adapter
2	Fitting
3	Fitting
4	Pressure reducer pilot tank connection

1. Install the fitting onto the pilot tank connection of the pressure reducer.
2. Install the pilot hose onto the fitting.

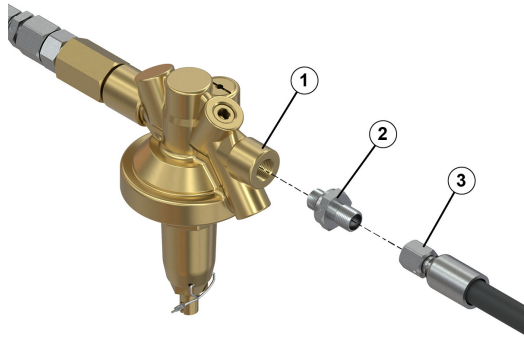

Figure 6.28: Installing the pilot hose to the pressure reducer

- | | |
|---|---------------------------------|
| 1 | Pressure reducer kit connection |
| 2 | Fitting |
| 3 | Pilot hose |

3. Install the fitting onto the kit-side of the pressure reducer.
4. Install the pilot hose onto the fitting.

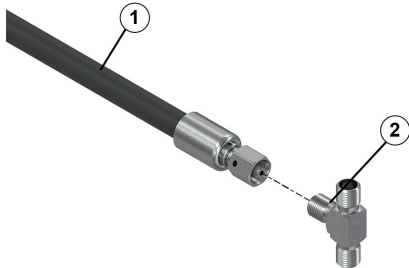

Figure 6.29: Installing the tee

- | | |
|---|----------------------------------|
| 1 | Pilot hose from pressure reducer |
| 2 | Tee fitting |

5. Install the tee connection on the kit-side pilot hose.



The pilot hose that connects to the time delay's output port must be installed first. If the input hose is installed before the output hose, installation of the output hose will be impossible.

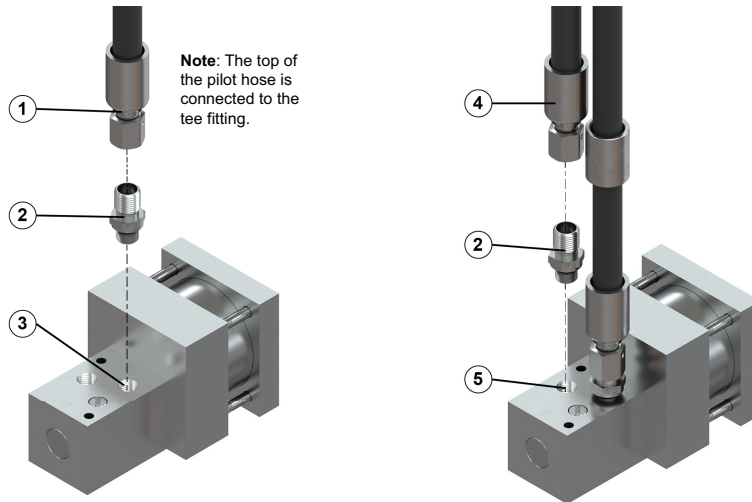

Figure 6.30: Install hoses to the pneumatic time delay

1	Pilot hose (output)	4	Pilot hose (input)
2	Fitting	5	Time delay input port
3	Time delay output port		

6. Install the fitting to the time delay output port.
7. Install the pilot hose onto the fitting.
8. Install the fitting to the time delay input port.
9. Install the pilot hose onto the fitting.

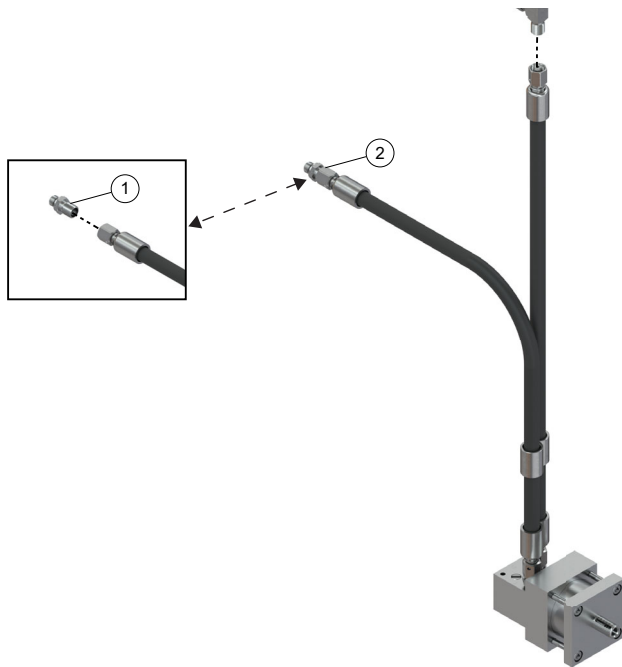

Figure 6.31: Install the pneumatic time delay

1	Fitting
2	To system

10. Install the fitting to the pneumatic time delay's output hose.
11. Install the input hose to the tee fitting.

Ensure that the pneumatic time delay is installed in the proper position. Improper positioning can hinder operation of the system.



The time delay relay must be assembled so that the marking on the enclosure is visible, the setting range of the delay time is visible, and the pneumatic pilot lines do not cross.

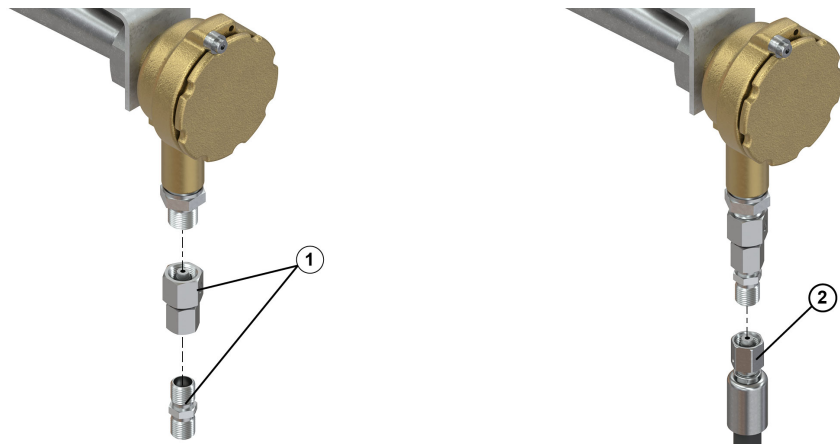

Figure 6.32: Installing pilot hose fittings to pneumatic horn

- | | |
|---|---------------------|
| 1 | Pilot hose fittings |
| 2 | Pilot hose |

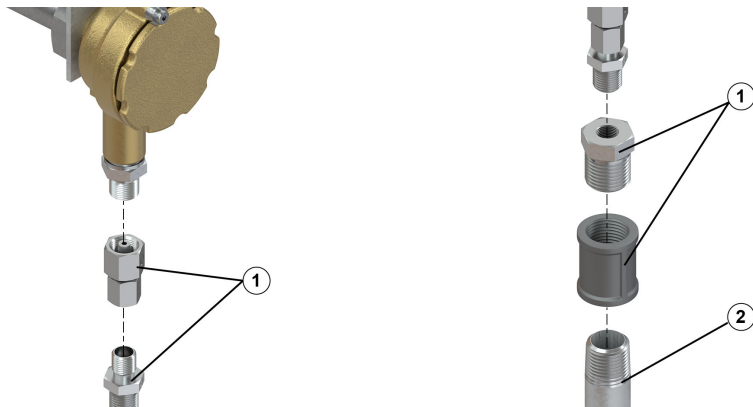

Figure 6.33: Installing hard pipe fittings to pneumatic horn

- | | |
|---|--------------------|
| 1 | Hard pipe fittings |
| 2 | Hard pipe |

12. Install either the hard pipe adapters or the pilot hose adapters to the pneumatic horn.

WARNING
Malfunction due to contamination of the horn

The functionality of the makrofon is not ensured if the inside of the horn is contaminated as a result of the makrofon being mounted in an unsuitable position.

- Mount the makrofon in such a way to ensure that the sound outlet is facing downward.

WARNING

The use of thread tape on compression/o-ring fittings may damage the seals.

- Only apply thread tape on tapered pipe threads.
- Do not apply thread tape to compression/o-ring fittings.

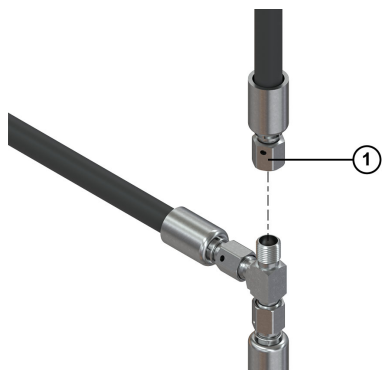

Figure 6.34: Installing pneumatic horn to tee using pilot hose

- | | |
|---|--------------------------------|
| 1 | Pilot hose from pneumatic horn |
| 2 | Pilot hose fittings |

13. When using pilot lines, Install the pilot hose to the pneumatic horn and tee fittings.
If using hard pipe, skip to Step 14.

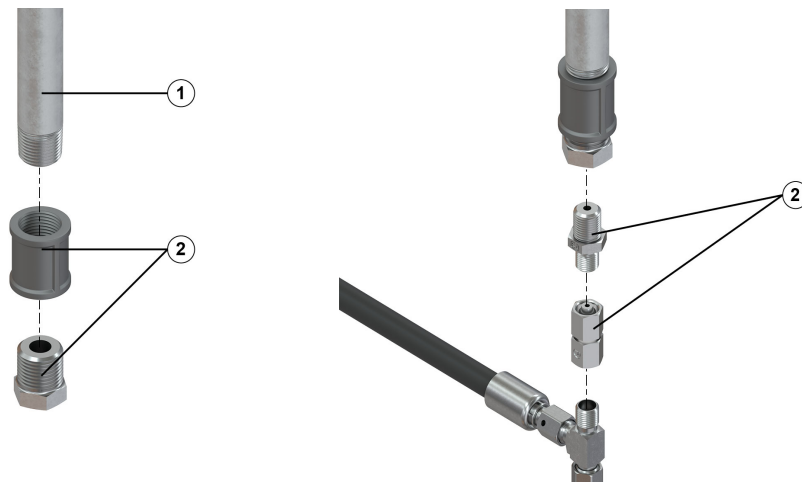

Figure 6.35: Installing pneumatic horn to tee using hard-pipe

- | | |
|---|-------------------------------|
| 1 | Hard pipe from pneumatic horn |
| 2 | Hard pipe fittings |

14. When using hard pipe, use hard-pipe fittings and thread tape to connect the pneumatic horn to the tee.



WARNING

Danger of the makrofon malfunctioning.

Changes to the makrofon may cause a malfunction in the event of an alarm sounding. This can cause severe injuries.

- Do not remove or loosen the cylinder screw.



WARNING

The use of thread tape on compression/o-ring fittings may damage the seals.

- Only apply thread tape on tapered pipe threads.
- Do not apply thread tape to compression/o-ring fittings.

NOTICE

Property damage due to disassembly of the horn.

The horn and housing are inextricably linked. The makrofon is heavily damaged and rendered unusable due to disassembly of the horn.

- Do not remove the horn from the housing.

**WARNING**

Danger of injury due to noise.

At operating pressure, the makrofon generates a sound pressure level that can damage human hearing.

- Mount the makrofon in a position that is not in the immediate vicinity of escape routes as much as is possible.

6.11.2 Testing the occupiable space kit



Before connecting the occupiable space kit with any source of compressed air, make sure that there is no connection between the pilot cylinder and the primary agent cylinder. Only connect the kit once it has been tested and the test air has been removed.



Figure 6.36: Testing the occupiable space kit

1 To shop air connection	2 To pressure reducer pilot cylinder connection
--------------------------	---

1. Test the occupiable space kit by connecting the pneumatic test kit to the pilot hose on the tank-side of the pressure reducer.
2. Run shop air through the test kit and into the system.



If the occupiable space kit has been correctly assembled, as soon as the shop air enters the kit the pneumatic horn should sound. Thirty seconds later, air should blow from the pneumatic time delay's outlet. If air blows from the outlet immediately, the pneumatic time delay has been installed incorrectly.

6.11.3 Connecting the occupiable space kit to the system

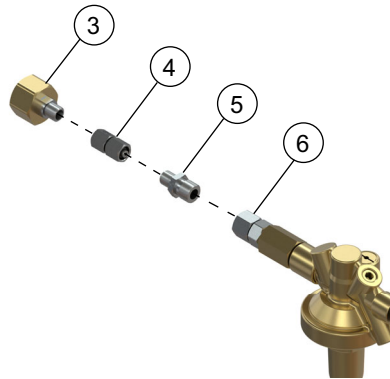

Figure 6.37: Installing adapter to pressure reducer

3	Pilot tank adapter
4	Fitting
5	Fitting
6	Pressure reducer pilot tank connection

3. Install the pilot tank adapter to the pilot line on the tank-side of the pressure reducer.

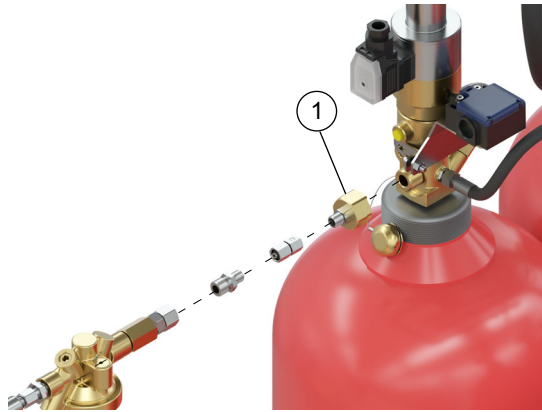

Figure 6.38: Connecting the occupiable space kit to the pilot tank

1 From pressure reducer pilot cylinder connection

4. Install the pilot line with adapter to the pilot tank to 40.6 ± 3.7 ft-lb.

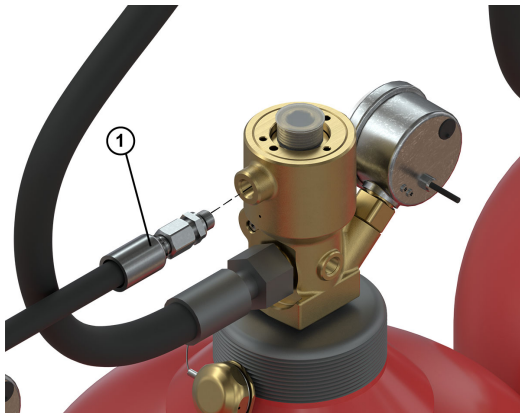

Figure 6.39: Connect the time delay output to first agent cylinder on the extinguishing tank rack

1 From output of pneumatic time delay

5. Install the pilot line from the pneumatic time delay output to the pilot input of the first cylinder on the extinguishing cylinder rack.

6.11.4 Connecting additional tanks in the system

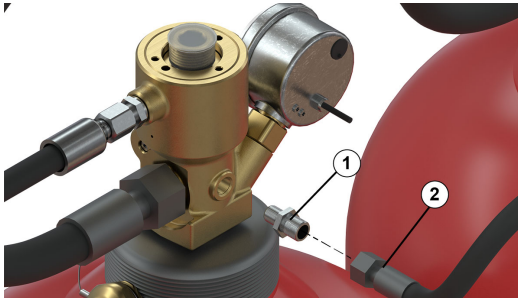

Figure 6.40: Install pilot line on the pilot output of the first agent cylinder on the extinguishing tank rack

- | | |
|---|------------|
| 1 | Fitting |
| 2 | Pilot line |

1. Install pilot line to the pilot line output of the first cylinder on the extinguishing rack.

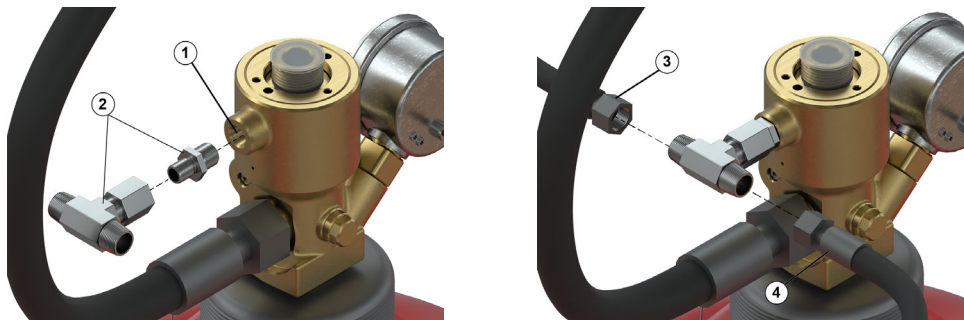

Figure 6.41: Install the pilot hoses between the cylinders

- | | |
|---|-----------------------------|
| 1 | Pilot line input connection |
| 2 | Tee fittings |
| 3 | To next cylinder |
| 4 | From previous cylinder |

2. Install the fittings and the pilot hose from the primary cylinder to the secondary cylinder pilot input.

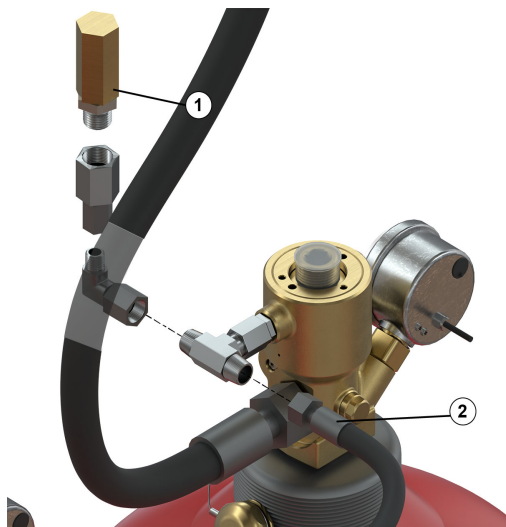

Figure 6.42: Install the relief device

- | | |
|---|------------------------|
| 1 | Relief device |
| 2 | From previous cylinder |

3. Install the relief device onto the tee connection of the last secondary cylinder.

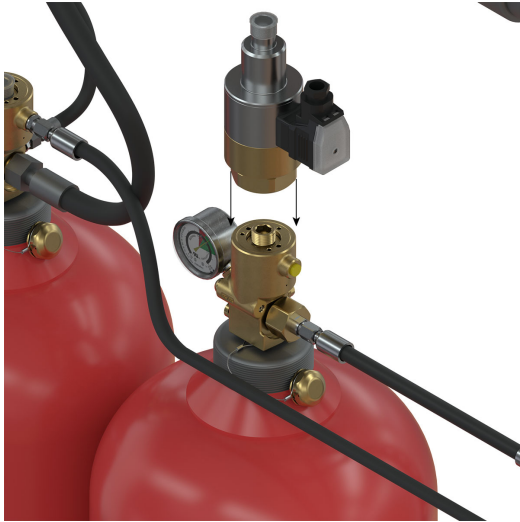

Figure 6.43: Install releasing solenoid to pilot cylinder valve
4. Install the releasing solenoid to the pilot cylinder valve.



Figure 6.44: Monitor device

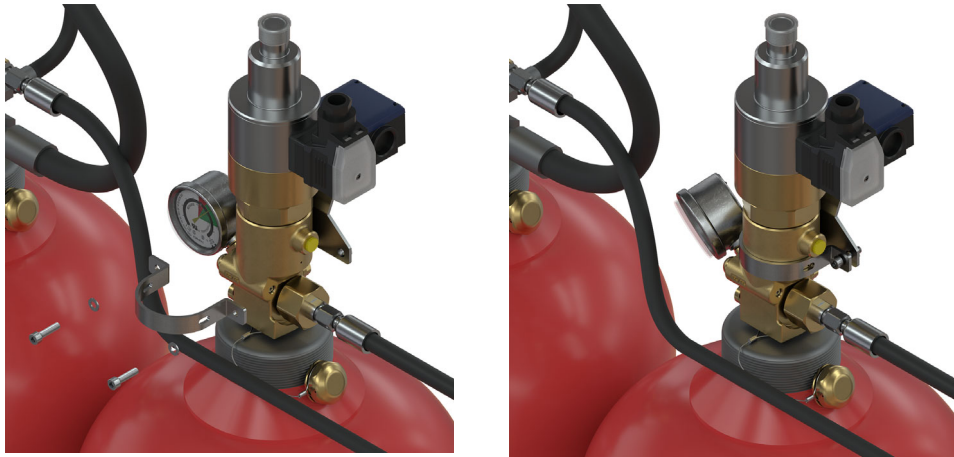

Figure 6.45: Install monitoring onto the releasing solenoid
5. Install the monitoring device onto the releasing solenoid.



WARNING

Danger due to incorrectly assembled pipe clamp

- **Make sure that the pressure relief bore of the valve is visible through the extended hole of the pipe clamp.**

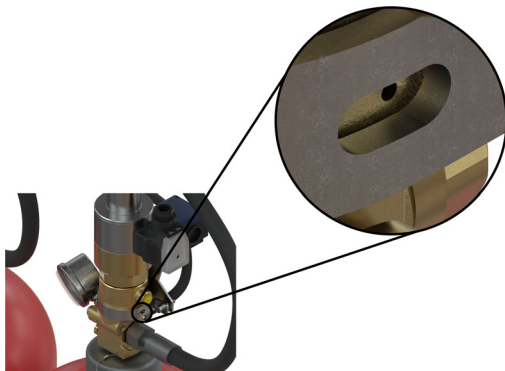

Figure 6.46: Proper monitor positioning

6.12 Installing the Manifold Relief Valve and Lockout Valves

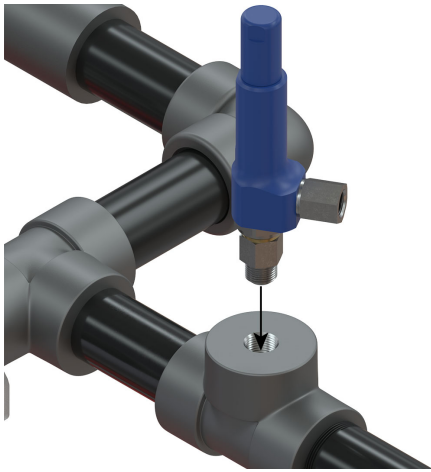

Figure 6.47: Install the manifold relief device

6. Install the relief device onto the T connection after the manifold.

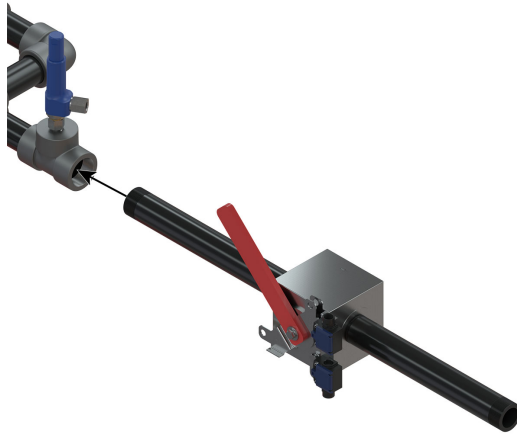

Figure 6.48: Install the lock out device

7. Install the lock out device onto the distribution pipe after the manifold.

6.13 Installing the Nozzles

Personnel:

- Installing contractor

Protective equipment:

- Industrial hard hat
- Safety gloves
- Safety footwear



WARNING

Risk of death due to improperly functioning nozzles

If the nozzles do not function properly, system function is not ensured. This can cause life-threatening injuries.

- Only use manufacturer provided sockets to install the nozzles.
- Never paint or cover nozzles.
- Do not undertake any structural changes in the protected enclosure that would affect the spray area of the nozzles.



CAUTION

Risk of injury caused by nozzle parts during mounting

Working overhead can pose a risk of injury from falling nozzle parts.

- Mount the nozzles in such a way that there is no risk of danger created by falling objects.



- The position, bore diameter, and number of nozzles in the fire extinguisher system must be specified by a calculation program prior to the installation.
- Structural changes of the protected enclosure require a new design of the entire system including the bore diameter of the orifices.

Completion of the nozzle body and assembly of the nozzle may be carried out in various sequences. Here, assembly of the nozzle body to the system piping with immediate or subsequent completion is described.

6.13.1 Mounting the VN Nozzle

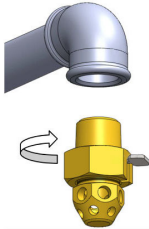

Figure 6.49: Mounting the orifice

1. Wrap the connection thread on the nozzle socket with a suitable sealant (e.g. PTFE sealing tape).
2. Using a standard socket wrench on the wrench flats of the nozzle socket, firmly screw the nozzle body into the fitting.

The nozzle typically comes with pre-installed orifice plate. If the pipe networks change, contact Viking Technical Services and provide an updated vInert or DesignManager flow calculation for orifice plate options.



WARNING

Excess thread tape can negatively effect nozzle performance.

- **Do not add thread tape in between the two brass components of the nozzle.**
- **Only apply thread tape to the nozzle connection thread.**
- **Tighten nozzle to pipe network using the mfg supplied socket to 45-55 ft-lb.**



VN Nozzles can be installed in either the pendant or upright orientation.

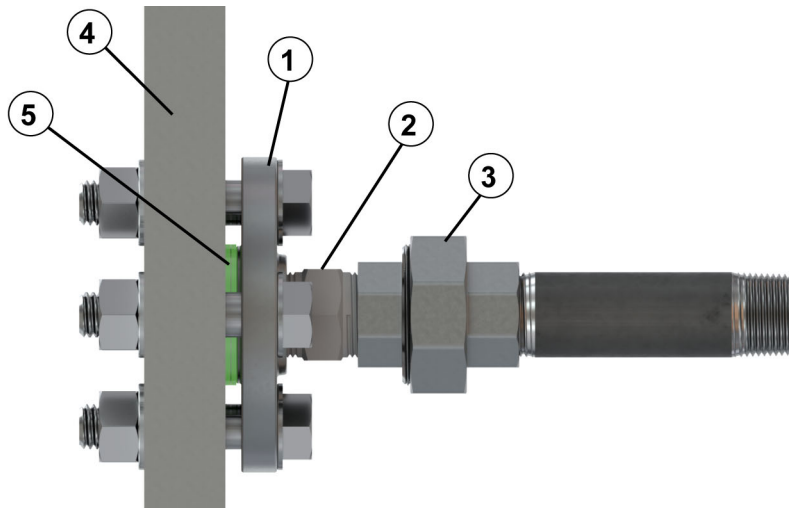

Figure 6.50: Typical DCM nozzle installation

1	Mounting flange	4	Side wall of enclosure
2	DCM Nozzle	5	Foil gasket (optional)
3	Union		



DCM Nozzles can only be installed in the sidewall orientation.

6.13.2 Mounting the DCM style nozzle with gasket (optional)

The nozzle must be located 1' from the top of the enclosure in order to achieve proper distribution of agent. The DCM nozzle is provided in either 1/2" NPT or 3/4" NPT thread on the inlet and outlet. With proper installation material, the nozzle can be mounted from the outside in bag houses, dust collectors, and machining centers. To prevent obstructions to the nozzle orifice, the foil gasket must be used. The nozzle must be installed in the calculation area and should never be directly over sensitive equipment or devices. Modifications to the DCM nozzles are not allowed.

6.14 Multi-zone Assembly

This section is only applicable if using a multi-zone setup. If multi-zone is not being used, refer to “System Assembly - Extinguishing Agent Containers” on page 73.

Personnel:

- Installing contractor

Protective equipment:

- Safety goggles
 - Safety gloves
 - Safety footwear
1. Install the pressure regulator to the pilot container.
 2. Install the MZ-1 input to the pressure regulator.
 3. Install the time delay onto the MZ-1.
 4. Connect the pneumatic horn and the selector valve to their appropriate connections on the MZ-1.
 5. Connect the various pilot tank zones to the corresponding connections on the MZ-1.
 6. Repeat step 4 for each extinguishing zone.



WARNING

Using thread tape on compression/o-ring connections can lead to damage of the pilot control system.

- **Do not apply thread tape to any items unless specifically listed.**
- **All compression/o-ring fittings should be assembled snug then tightened 1/4 turn**

7 Electrical Connections

Personnel:

- Qualified electrician



DANGER

Danger of electrocution

There is a real and immediate danger of electrocution when touching live parts. Damage to the cable insulation at individual components may result in death. Furthermore, incorrect connection can cause the system to malfunction.

Have work on electrical components and on the electrical connection carried out only by qualified electricians. If damage to the cable insulation is detected, switch off the power supply immediately and replace the defective cables with identical new ones.

Before starting any work at components of the electrical systems and operating equipment, disconnect the power supply and make sure it cannot be reconnected while work is being carried out. Observe the five safety rules:

- Disconnect completely.
- Secure against reconnection.
- Verify that the installation is dead.
- Carry out grounding and short circuiting.
- Protect against adjacent live parts.

Never bypass fuses or put them out of operation. Replace defective fuses only with fuses with the same amperage and tripping characteristic. Keep moisture away from live parts. Moisture may cause a short circuit.



For monitored electrical circuits as per NFPA, the wiring between the limit switch and the connection socket must be protected by a flexible metal cable conduit.

7.1 Supervisory Switches

7.1.1 Supervisory switch for monitoring electrical release solenoids, lockout valves, and selector valves

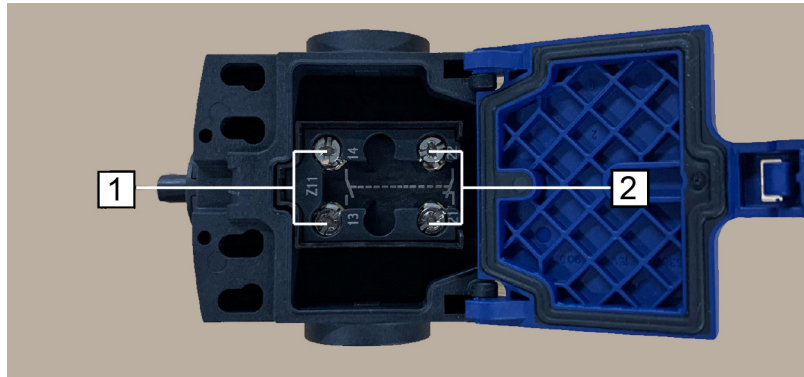

Figure 7.1: Supervisory switch wiring connections

- 1 Wiring connections for normally closed configuration
- 2 Wiring connections for normally open configuration

This supervisory switch is used to monitor all electrical release solenoids, lockout valves, and selector valves.

Data	Value	Unit
Switch current at 240 V AC (controlled with Ac voltage)	3	A
Switch current at 24 V DC (controlled with DC voltage)	3	A
Rated insulating voltage U_i	300	V
Protection type	IP 67	

7.1.2 Supervisory switch for the pneumatic limit switch

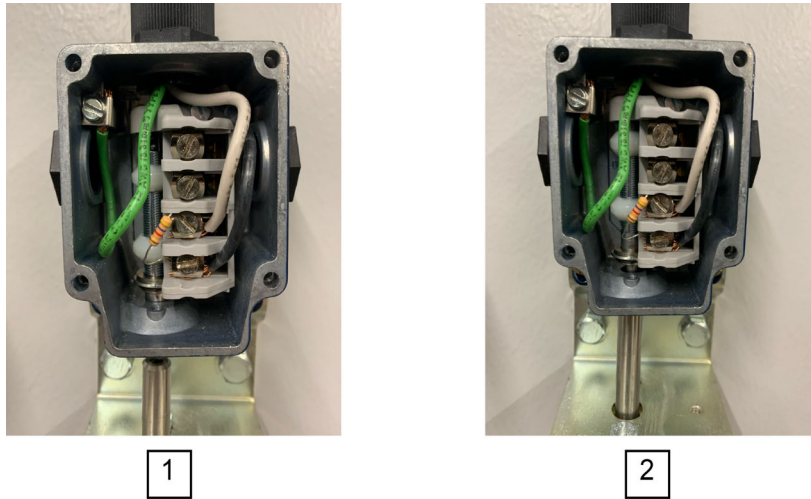

Figure 7.2: Normally closed and normally open position of supervisory switch

- | | |
|---|-----------------------------------|
| 1 | Default position; normally closed |
| 2 | When pushed; normally open |

This supervisory switch is only used with the pneumatic limit switch.

Data	Value	Unit
Switch current at 400 V AC (controlled with Ac voltage)	6	A
Switch current at 24 V DC (controlled with DC voltage)	1	A
Rated insulating voltage U_i	500	V
Protection type	IP 67	

Supervisory switch for pressure gauges

The pressure gauge supervisory switch is an internal component of the pressure gauge.

Data	Value	Unit
Switch voltage	4.5/24	VDC/ VAC
Switch current	5—100	mA
Maximum contact load	2.4	W
	0.00322	hp
Degree of protection	IP65	-

8 Commissioning

**WARNING****Risk of injury due to incorrect sequence of commissioning**

With incorrect sequence of commissioning, there is a danger of accidental activation. A faulty release of the system may cause severe injuries and property damage.

- **For the commissioning (initial or subsequent commissioning, as well as after activation), the following sequence of commissioning must be adhered to.**

A successful commissioning test is the prerequisite and final assembly procedure for a system transfer to the operator. Therefore, not only the function test must be completed flawlessly, but the entire system must also be in a commissionable state.

Before commissioning, the acceptance checklist must be used to determine that the entire system is in compliance.

Sequence of commissioning

1. Ensure that no supervisory signals are present on the fire control panel.
2. Remove all solenoids (and pilot control lines) from the system. Ensure supervisory signals appear on the fire control panel.
3. Initiate the releasing sequence on the fire control panel.
4. Reset the fire control panel and ensure that all alarms are no longer active.

DANGER Replacing the solenoid without first resetting it will result in an accidental discharge.

5. Reset the solenoid and reinstall it on the primary agent cylinder or pilot control cylinder.
6. Ensure that no supervisory signals are present on the fire control panel.
7. If a pilot cylinder is used, ensure that all pilot lines are disconnected (or the system will discharge during testing).
8. Use the manufacturer provided pneumatic test kit to test the pilot system using shop air pressure and validate that all pneumatic components activate as intended.
9. Once pneumatic testing is complete, reconnect the pilot lines.

8.1 Preparations

Personnel:

- Installing contractor

Protective equipment:

- Safety goggles
- Safety gloves
- Safety footwear

Material:

- Test device for pneumatic actuation (part no. 25761)
- Any air supply under 144 psi



WARNING

Risk of injury due to faulty release.

Faulty release of the system may cause serious injuries or death and significant property damage.

- **Carry out all functional tests during commissioning, servicing and repair work so that the system is not activated.**
- **Before starting work, always carry out the following tasks.**

8.2 Testing the Function of Releasing Solenoid

Personnel:

- Installing contractor

Material:

- Release device reset tool (part no. 934652)



Ensure that the electrical release solenoid is not attached to the cylinder valve.



DANGER

Risk of death due to accidental discharge.

Make sure that the release pin is in the Deactivated position.

1. Apply power to the electrical release solenoid to activate the device and pop the release pin into the active position.
2. Use the reset tool to reset the release pin back into the non-active position.
3. Ensure that all panel faults are clear.
4. Reinstall on the agent cylinder to a torque of 18.44 ± 2.95 ft-lb.

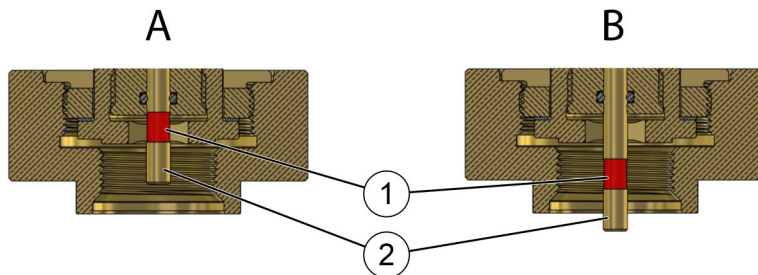

Figure 8.1: Release pin deactivated (A) and activated (B)

1	Marking
2	Release pin

8.3 Testing the Function of the Selector Valve

Personnel:

- Installing contractor

Protective equipment:

- Safety goggles
- Safety gloves
- Safety footwear



CAUTION

Risk of injury due to pressurized parts.

With regard to the functional test for the selector valve, there is a risk of injury due to the pneumatic control pressure.

- **Only use the approved components.**
 - **Check that all connections are secure.**
 - **With regard to the initial functional test, adhere to the safety distance of 7ft (2m) and wear protective goggles.**
1. Check fittings for tightness and intact security paint.
 2. Test alignment of the limit switch to the rotating adapter.



When the selector valve is closed, the limit switch is activated.

When the selector valve is open, the limit switch is not activated.

Check ease of movement

3. Remove the position indicator.
4. Insert the wrench and open/close the selector valve two-three times. If the selector valve cannot be opened by hand, it must be replaced.
5. Remove the wrench.
6. Put on and fasten the position indicator.
7. Perform the functional test.
8. Check whether the selector valve is in the closed position.

8.4 Testing Function of Control Unit MZ-1

Personnel:

- Installing contractor

Protective equipment:

- Safety goggles
- Safety gloves
- Safety footwear

Material:

- Test device for pneumatic actuation
- Any air supply under 144 psi

8.4.1 Functional test of the control unit

1. Disassemble the pilot cylinder from the compressed air supply.
2. Secure the extinguishing agent against activation.
3. Connect the pneumatic test kit to the compressed air supply.
4. If applicable, open the valve to the compressed air supply. Use the pressure control for the control unit to reduce the compressed air supply to a maximum 140 psi (10 bar).
5. The pressure is then present in the control unit.
6. Use the fire alarm control panel to actuate the electrical control module.
7. The selector valve opens without a delay and the extinguishing zone's pneumatic horn activates
8. The pressure relief devices on the control unit are also activated. Activation can be checked by quickly pressing on the pressure relief devices.
 - Compressed gas escapes
9. Press the pressure relief device on the release module.
 - Compressed gas escapes
10. Close the valve to the compressed air supply and remove the pneumatic test kit.

11. Depressurize the control unit. To do so, press the pressure relief device for some time until the control unit is fully depressurized.
12. Reassemble pilot lines.
13. Close the selector valve manually.
14. Put the fire alarm control panel in the functional condition.
15. If the control unit has several zones, the test procedure must be repeated for each area.

8.4.2 Functional test for the disable device

1. Make sure the control unit is no longer pressurized. Only perform the functional test when in a depressurized state.
2. Set the disable device to the “Blocked” position using an allen wrench.
3. On the fire alarm control panel, check whether the block has been reported.
4. Reset the disable device to the “Operational” position using an allen wrench.
5. On the fire alarm control panel, check whether the removal of the block has been reported.

8.4.3 Functional test of main/reserve change-over

1. Make sure the control unit is no longer pressurized. Only perform the functional test when in a depressurized state.
2. Remove the lock and shut-off plate.
3. Move the switch to the “reserve” position.
4. Secure the switch position using the locking pin.
5. On the fire alarm control panel, check that the switch over to the “reserve” has been reported.
6. Remove the locking pin
7. Move the switch to the “main” position
8. Secure the switch position using the locking pin
9. On the fire alarm control panel, check that the switch over to the “main” has been reported.

8.4.4 Functional test of electrical control module

1. Make sure the control unit is no longer pressurized.
2. Activate the electrical control module using the fire alarm control panel.
3. Pay attention to the “clicking” of the electrical control module and check that the red LED is illuminated.
 - If the red LED is illuminated, the electrical control module has activated.
4. On the fire alarm control panel, reset the electrical control module.
 - The red LED on the electrical control module is no longer visible.

8.5 Checking Pneumatic Time Delay Function

Personnel:

- Installing contractor

Protective equipment:

- Safety goggles
- Safety gloves
- Safety footwear

Material:

- Pneumatic test kit



Make sure to test all pneumatic equipment in conjunction with the pneumatic test kit.



WARNING

Risk of malfunction and resulting injuries

Always carry out the functional test/adjustment using nitrogen (N₂) at a pressure of less than 140 psi (10 bar).

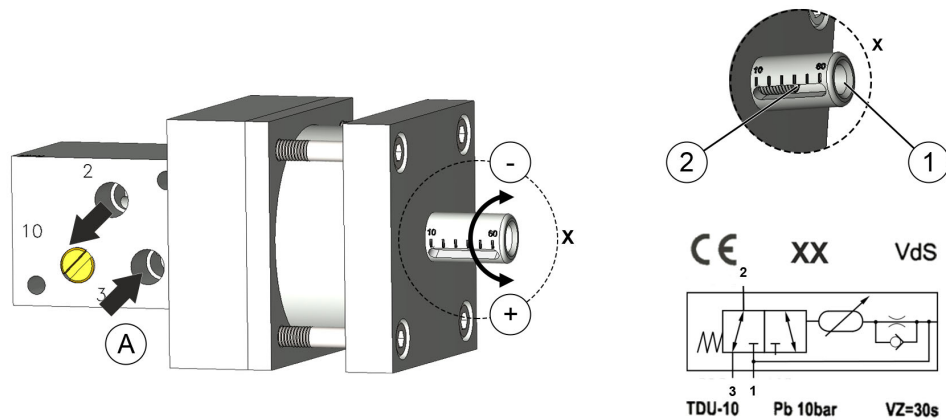

Figure 8.2: Testing the time delay unit

1	Adjusting spindle
2	Test pressure gauge
A	Pressurized connection

1. Connect the pneumatic test kit directly to the pressurized connection [1] on the time delay unit at a maximum pressure of 140 psi (10 bar).
2. Pressurize the time delay unit and measure the delay time.

i The adjusting spindle is pre-set to 30 seconds and should not be modified. If the sealing wax that locks the adjusting spindle is broken, the manufacturer does not guarantee that the time delay will function

i The permitted deviation from the target value is +20/-0% [according to NFPA 2001 and UL/FM]

8.6 Checking the Function of the Pneumatic Horn (Makrofon)

Protective equipment:

- Hearing protection

Pneumatic horns (Makrofons) are tested in the course of extinguishing zone activation. When the selector valves are activated, the pneumatic horn is clearly audible in the extinguishing zone.

8.7 Establishing Operational Readiness

1. Check that no alarms are active on the electrical control device and, if necessary, on the superordinate SRP.
2. Check if the testing supply is disconnected from the pneumatic control circuit.
3. Ventilate the pilot line.
4. Check if the selector valves are closed.
5. Check if the extinguishing agent containers are operational:
 - The release devices are pneumatically connected.
 - The test pressure gauges are removed.
6. Check if the pilot cylinder is operational:
 - The electrical release solenoid is mounted with a torque of 18.4 ± 3 ft-lb (25 ± 4 Nm).
7. Check if the switch levers of the lock out devices are in the "OPERATIONAL" position and if the switch levers are secured with padlocks.
8. Check if the electric control device/SRP is in functional condition and that no shut-offs are active.

9 Design, Function, and Operation

9.1 Functional Description

If at least two fire detectors located within the protection zone detect a fire, or if the manual release is activated, the SRP sets the activation state and electrically activates the pneumatic control of the pilot cylinder immediately.

In systems without life safety, the activation pulse is issued to the electrical release solenoid of the system once a set pre-warning time passes.

In systems with life safety measures, the control gas is guided to the pneumatic alarm device (makrofon) and the non-electrical time delay unit immediately. Once the set delay time passes, the extinguishing agent containers assigned to the extinguishing zone are opened pneumatically.

The extinguishing agent flows from the extinguishing agent containers through a manifold with check valves into the open selector valve. The extinguishing agent then flows through the pressure reducer and reaches the discharge nozzles through the low pressure system piping. The discharge nozzles distribute the extinguishing agent evenly in the extinguishing zone.

To fight the fire, the extinguishing agent reduces the relative oxygen level in the air through oxygen displacement.

To divert the resulting overpressure and the oxygen away from the extinguishing zone, a pressure relief vent is mechanically, pneumatically, or electrically opened for the flooding period at minimum.

As well as the automatic electric release, the system can also be activated manually using manual electric releases. These releases are usually installed at the extinguishing zone access point.

For more details and information about the variants of the manual release for the system, see the applicable local regulations.

9.1.1 Single-container systems



Figure 9.1: Single container system connection line

Single container systems only use a single extinguishing agent container. They are used solely for small extinguishing zones. Single container systems have an electric release device that is fitted to the extinguishing agent container valve. Optionally, a mechanical manual release device for manually activating the system can be fitted on the electric release device.

Single container systems with a pneumatic release device have an electrically actuated pilot cylinder. The control gas flows through a pilot line from the pilot cylinder to the pneumatic release device for the extinguishing agent container and opens it.



Use single container systems without a pilot cylinder only if you have ensured that the MDC and egress time conform to limits as specified in NFPA 2001.

9.1.2 Multi-container systems



Figure 9.2: Multi-container system

Multi container systems feature several extinguishing agent containers interconnected via a pilot line. They are required, for example, if a large protection zone must be protected.

In multi-container systems without a pilot control cylinder, the first extinguishing agent container (primary) is actuated electrically (with options for manual releases) in the same way as in single container systems. All other extinguishing agent containers (secondaries) are opened pneumatically through a pilot line.

Multi container systems with a pilot control cylinder feature a pilot cylinder that is triggered electrically. The control gas flows via pilot line from the pilot cylinder to the primary cylinder valve for the extinguishing agent containers and opens them.

In contrast to single container systems, the extinguishing agent first flows from the hose through check valves into a manifold if a multi container system is actuated. From there, the extinguishing agent flows through the low pressure system piping to the discharge nozzles where it escapes into the extinguishing zone.

9.1.3 Single zone systems

Single zone systems protect one extinguishing zone and can consist of one or several extinguishing agent containers.

9.1.4 Multi-zone systems

Multi-zone systems safeguard several extinguishing zones. The supply of extinguishing agent and thus the number of extinguishing agent containers is always

based on the largest extinguishing zone. When activated, the system will only flood one extinguishing zone.

Multi-zone systems are equipped with a pilot control cylinder. The pilot cylinder of these systems is activated electrically if a fire is detected. The control gas flows through the pilot line to the multi-zone control valve (MZ-1). The MZ-1 then sends pilot pressure to and activates the required number of cylinders for activation.

Activation of an extinguishing zone

The electrical control and control modules for the control unit MZ-1 ensure that the selector valve assigned to the respective extinguishing zone is opened and the appropriate cylinders are released. The extinguishing agent then flows only into the zone that has detected a fire and causes the system to activate. The extinguishing agent then flows from the hose through check valves and into the manifold and system piping of the activated zone. Only one extinguishing zone can be flooded at any time.

9.2 Oxexo Unistrut Racking Arrangements

For information pertaining to system racking, see Figure 14 on page 223.

9.3 System piping

Pipes and fittings make up the system piping between the extinguishing agent cylinders and discharge nozzles.

The system piping for Oxeo inert gas extinguishing systems is divided into two different areas:

- High pressure system piping (PR only): The area of the high pressure system piping starts at the manifold and ends at the pressure reducer. The selector valves and manifold pipes are also located in the high pressure system piping for multi-zone systems.
- Low pressure system piping: The area of the low pressure system piping starts behind the pressure reducer and ends at the nozzles. For constant flow systems, the low pressure system piping starts at the manifold and ends at the nozzles.

The design of the system piping including the required pipe cross sections must be executed through a hydraulic calculation program recognized by the manufacturer.

i Changes in the pipeline routing require a new hydraulic calculation. Changes in pipe cross section, extinguishing agent cylinder size, pressure reducer and nozzle bores can occur.

i NFPA 2001 provides all relevant system piping requirements with further explanations found in the FSSA Pipe Design handbook.

9.4 Manifolds, 2” NPT

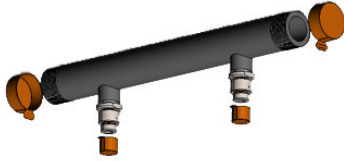

Figure 9.3: Manifold with 2 inlets



Figure 9.4: Manifold with 3 inlets

Manifolds serve as a shared connection for the extinguishing agent containers on the system piping.

Manifolds are intended for a one-, two-, or three-row set-up of extinguishing agent containers, are available with 2 to 3 inlets, and are pressure tested at the factory.

Different manifolds are available for PR and CF systems.

Manifolds with larger outlet spacing will be required for 140L cylinders.

9.5 Check Valve



Figure 9.5: Check valve

The check valve is used in inert gas extinguishing systems. The check valve enables the flow of extinguishing agent in the flow direction and prevents it from flowing in the opposite direction. The check valve is an approved system component.

9.6 Extinguishing Cylinder with Quick Release Valve



Figure 9.6: Extinguishing agent container and valve protection cap

The extinguishing agent is stored in one or more extinguishing agent containers that are kept in a suitable racking apparatus. For safety reasons, the container batteries must be fastened to load-bearing parts of the building (wall and/or floor).

The extinguishing agent containers are designed, produced and marked in accordance with American standards (e.g. DOT) or other country-specific pressure equipment guidelines. An appropriate label is attached to each extinguishing agent container.

9.6.1 Quick release valve

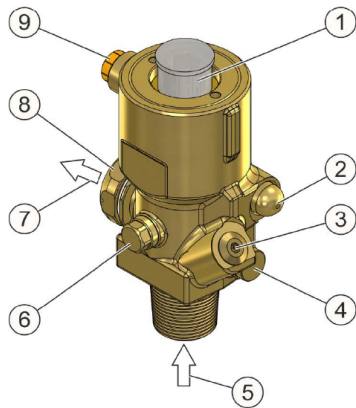

Figure 9.7: Quick release valve

1	Thread for manual/electrical release solenoid	6	High pressure pilot port
2	Pressure relief button for the filling process	7	Valve output
3	Pressure gauge connection	8	Outlet venting safety plug
4	Bursting disc safety device	9	Pneumatic release port
5	Valve inlet		

The quick release valve is installed on an extinguishing agent container and can be opened pneumatically, electrically, or manually. When the valve is open, the extinguishing agent flows through the pipelines to the extinguishing nozzles.

The valve works according to the differential pressure system. By activating a release device, the pilot valve integrated in the valve is opened and the upper pressure chamber is vented. This drop in pressure causes the extinguishing agent container pressure to press the closing piston in the opened position, opening the valve.

The valve is fitted with an integrated pneumatic release device. In addition, an electrical release solenoid and/or manual release device can be fitted onto the valve.

To protect against impermissibly high pressure, each valve is equipped with a burst disk device.

Each valve includes a pressure gauge connection with an integrated check valve and control connection.

The quick release valve is a total discharge (TD) valve, meaning that following activation, the valve remains open until the extinguishing agent container is empty (with the exception of the remaining residual pressure; see below).



If the pressure in the extinguishing agent container is approximately 22 psi (1.5 bar), the valve closes automatically. There is always a residual pressure in the extinguishing agent container.

9.6.2 Manual release device

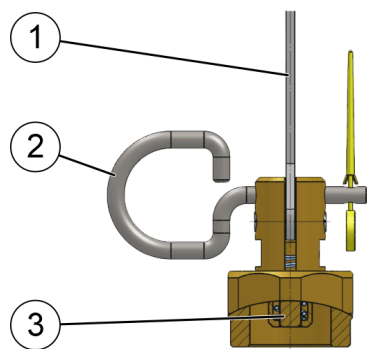

Figure 9.8: Release device, manual

1	Manual lever
2	Safety pin
3	Release pin

The manual release takes place by pressing the manual lever until it stops, which pushes the release pin downwards and activates the quick release valve. The safety pin must be removed before manual release. The manual release lever must be held for at least 5 seconds to ensure activation.

The release device can also be assembled on the electrical release solenoid as an additional release device.

9.6.3 Electrical release solenoid

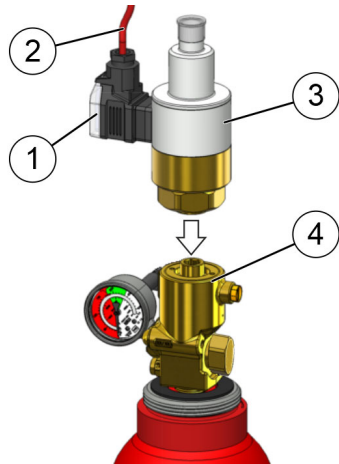

Figure 9.9: Electrical release solenoid

1	Electrical connection	3	Electrical release solenoid
2	Cable leading to control panel	4	Cylinder valve

The electrical release solenoid activates the valve electrically. The electrical release solenoid is connected to the SRP via a cable. The electrical signal must be applied for at least 5 seconds to ensure an activation. Please consult panel manufacturer for compatibility of the electrical release solenoid.

9.6.4 Monitoring of electrical release solenoid

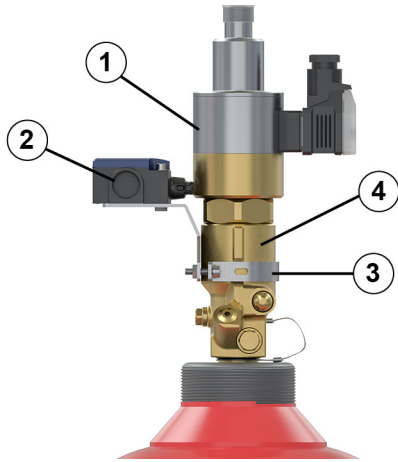

Figure 9.10: Monitoring, assembled

1	Electrical release solenoid	3	Monitor switch mounting clamp
2	Monitor switch	4	Cylinder valve

The monitor switch serves to check for the presence and correct assembly of the electrical release solenoid on the valve.

If the release device is present and correctly assembled, the monitoring switch is activated. If the release device is disassembled or incorrectly assembled, the switch is not activated and transmits a signal to the SRP. There, the absence or incorrect assembly of the electrical release solenoid is displayed as a fault.

The monitor switch is mounted on the valve with the mounting clamp.

9.6.5 Supervised pressure gauge

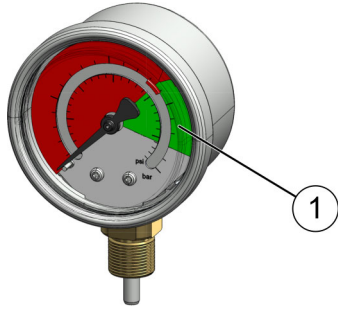

Figure 9.11: Supervised pressure gauge

1 Less than 10% pressure loss

Each valve has a connection for a supervised pressure gauge. This connection is closed with a plug. Pressure gauges must be ordered separately from the cylinders.

Since the connection is fitted with a check valve, the supervised pressure gauge can be assembled even if the extinguishing agent container is pressurized.

The automatic loss monitoring is set to a 10% pressure loss (scale area marked in green) based on the nominal filling pressure.

Table 9-1:

Part no.	Nominal pressure	Pressure range	Switching point
927612	2901 psi (200 bar)	4351 psi (300 bar)	2611 psi (180 bar)-NO under pressure
927615	2901 psi (200 bar)	4351 psi (300 bar)	2611 psi (180 bar)-NC under pressure
927616	4351 psi (300 bar)	6527 psi (450 bar)	3916 psi (270 bar)-NO under pressure
921617	4351 psi (300 bar)	6527 psi (450 bar)	3916 psi (270 bar)-NC under pressure

9.7 Hose for Extinguishing Agent

The hose serves as a flexible connection between the extinguishing agent container and the manifold. The hose is provided with unions at both ends. Seals in the unions are required for proper function. Both hoses come with gaskets 149890 and 149970 included. Gaskets 149890 and 149970 can also be ordered as spare parts.

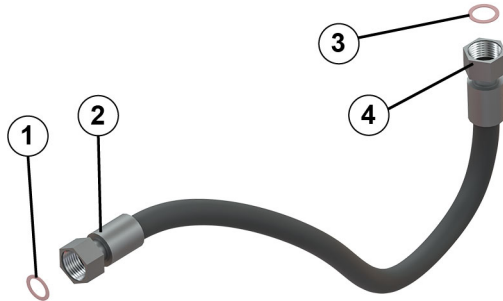

Figure 9.12: Hose

1	Seal	3	Seal
2	Union	4	Union

Table 9-2:

Designation	Length [in. (mm)]	Thread G1	Thread G2	Part no.
Agent hose, 375 mm long	14.8 (375 mm)	W21.8 x 1/14 DIN 477	G3/4 ISO 228	934921D
Agent hose, 600 mm long	23.6 (600 mm)	W21.8 x 1/14 DIN 477	G3/4 ISO 228	934922D*
CF hose kit w/ regulator, 375 mm long	14.8 (375 mm)	W21.8 x 1/14 DIN 477	G3/4 ISO 228	25763
CF hose kit w/ regulator, 600 mm long	23.6 (600 mm)	W21.8 x 1/14 DIN 477	G3/4 ISO 228	25764*
*Parts are special order only				

9.8 Pilot Hoses for Activation of Secondary Cylinder



Figure 9.13: Pilot hose

The pilot hose (5/32") serves as a flexible connection between the valve of the primary extinguishing agent container and the pneumatic release device of a secondary extinguishing agent container. The pilot hose is also used to connect other secondary extinguishing agent containers to each other. Pilot hoses are also used to connect pneumatic horns, time delays, and multi-zone equipment.

The primary/secondary combination is only used if no pilot cylinder is required and there are no life safety requirements.

Both connections have a thread of M12 x 1.5 and 24° sealing cone (light series) with O-ring (DKOL).

NOTICE

Use the bend radius tool (part no. 26408; sold separately) for assistance.



WARNING

Risk of injury or product damage due to escaping high pressure gas.

- Do not bend the hose less than its MINIMUM radius of 2 inches (45 mm).

Table 9-3: Pilot Hose Part Numbers

Designation	Thread	Part no.
20" Flexible Oxeo pilot hose	M12 x 1.5	24467
39" Flexible Oxeo pilot hose	M12 x 1.5	24468
59" Flexible Oxeo pilot hose	M12 x 1.5	24469
20" Flexible Oxeo pilot hose, kit	See tech data	25132

Table 9-3: Pilot Hose Part Numbers

39" Flexible Oxexo pilot hose, kit	See tech data	25133
59" Flexible Oxexo pilot hose, kit	See tech data	25134

9.9 Selector Valves

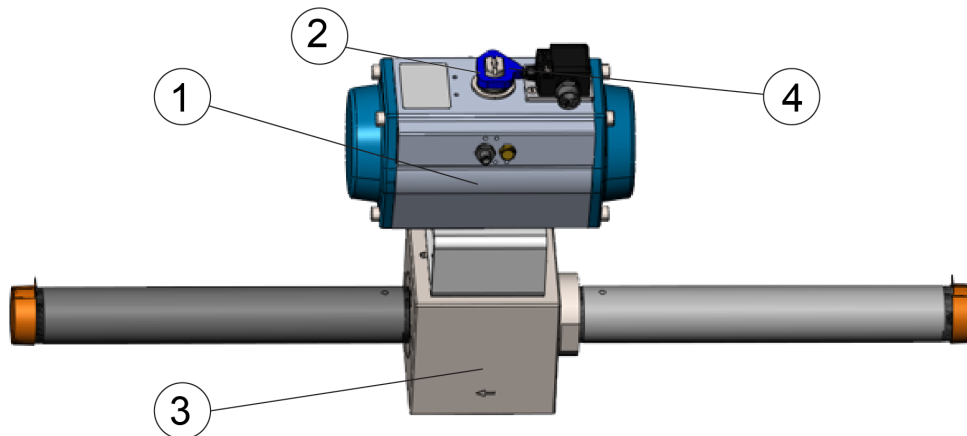

Figure 9.14: Selector valve

1	Rotary drive
2	Position indicator
3	Ball valve
4	Limit switch

The selector valve consists primarily of a ball valve coupled with a pneumatic rotary drive.

Once a fire is detected in an extinguishing zone of a multi-zone system, the selector valve associated with the extinguishing zone is opened by the pneumatic rotary drive and the extinguishing agent flows to appropriate nozzles via the system piping.

To return the installation to service, the selector valve is closed manually using a wrench. The correct position of the selector valve can be monitored electrically by a limit switch and optically by the position indicator. If the selector valve is closed, the position indicator is at a right angle to the direction of flow. If the position indicator is aligned with the direction of flow, then the selector valve is open.

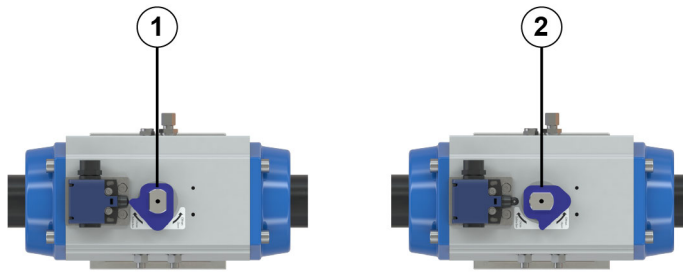

Figure 9.15: Position indicator

- | | |
|---|---|
| 1 | Position indicator when valve is closed |
| 2 | Position indicator when valve is open |

9.10 Monitored Lock Out

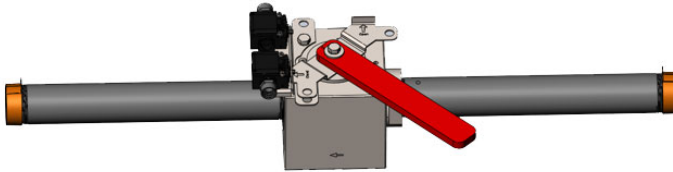

Figure 9.16: Monitored lock out device

The monitored lock out device is comprised of a ball valve, electrical monitoring component, and a manually operated lever. The lock out device is to be installed before the pressure reducer in PR systems and can be installed anywhere between the manifold and the nozzles in CF systems. Lock is NOT included. Refer to the appropriate technical data sheet for more information.

9.11 Pressure Reducer (PR Systems Only)

The pressure reducer reduces the pressure of the high pressure pipe network. The pressure reduction occurs by means of an orifice, the diameter of which is dependent on the extinguishing agent throughput and is determined by the pipe system via vInert or DesignManager. It is installed between the high pressure pipe system (3408 psi and 5294 psi or 235 bar and 365 bar) and the low pressure pipe system, whereby any combination (if available) of the inlet and outlet connection threads are possible. The pressure reducer is produced with conical inner thread in accordance with two different standards:

- ISO 7
- ANSI/ASME B1.20.1-NPT

Orifice diameters are indicated by a four digit suffix. For example, part number 25014-0118 would correspond to a 2" NPT inlet / 2" NPT outlet pressure reducer with a 0.118" orifice diameter. See Technical Data Sheet for all available pressure reducer configurations and maximum orifice sizes.

The pressure reducer is available in two different variants:

- Pressure reducer with orifice for hole diameters of 0.118 in. (3 mm) to 1.811 in. (46 mm)
- Pressure reducer with orifice and protective screen for hole diameters of 0.039 in. (1 mm) to 0.114 in. (2.9 mm)

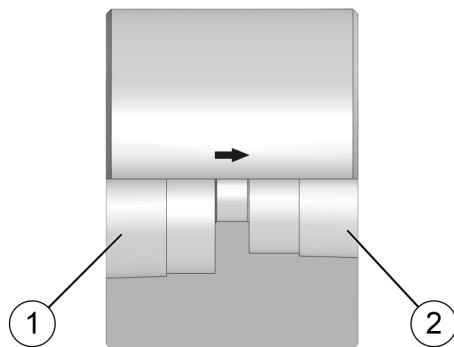

Figure 9.17: Pressure reducer

1	Inlet side
2	Outlet side

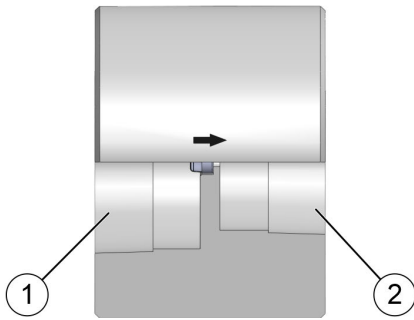

Figure 9.18: Pressure reducer with protective screen

Table 9-4: Pressure Reducer Part Numbers

Designation	Base part no.
Pressure reducer 3/4" BSPT / 3/4" NPT with protective screen ^{*1}	25011
Pressure reducer 3/4" BSPT / 3/4" NPT ^{*2}	25012
Pressure reducer 2" NPT / 2" NPT with protective screen ¹	25013
Pressure reducer 2" NPT / 2"NPT ²	25014
Pressure reducer 2" NPT / 2-1/2"NPT with protective screen ¹	25015
Pressure reducer 2" NPT / 2-1/2"NPT ²	25016
Pressure reducer 2" NPT / 3" NPT with protective screen ¹	25017
Pressure reducer 2" NPT / 3" NPT ²	25018
<p>*Configuration available in single tank systems only</p> <p>¹Orifice diameters range from 0.039" (1.0 mm) to 0.114" (2.9 mm)</p> <p>²Orifice diameters start at 0.118" (3.0 mm)</p> <p>NOTE: Only base part numbers shown. For the complete ordering number, refer to the Technical Data Sheet.</p>	

9.12 Constant Flow Regulator (CF Systems Only)

The constant flow regulator is specifically intended for use in CF inert gas extinguishing systems. Once installed between the discharge hose and the check valve, the regulator serves to reduce the system from 2900 psi (200 bar) or 4350 psi (300 bar) to a lower pressure level for downstream system piping.



Figure 9.19: Constant flow regulator

9.13 Manifold Safety Valve



Figure 9.20: Safety valve (example)

1	Safety valve	2	Valve outlet
---	--------------	---	--------------

Safety valves are used to protect components against excessively high pressures, e.g. on manifolds.

In the event of an excessively high pressure, the safety valve ensures pressure relief. A blow-off line attached to the outlet on the safety valve leads the medium to safely discharge on the outside.

9.14 Occupiable Space Protection Kit

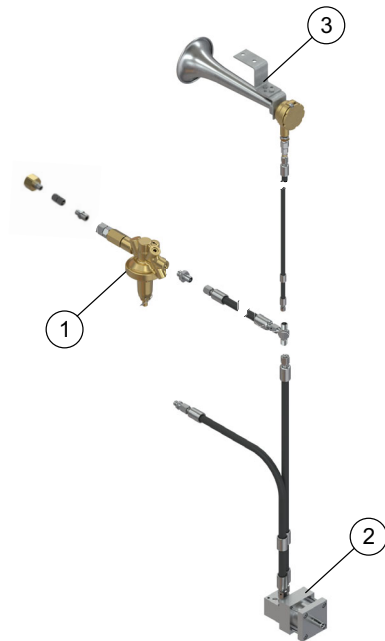

Figure 9.21: Occupiable space protection kit assembly

- | | |
|---|----------------------------------|
| 1 | Pressure reducer on page 156 |
| 2 | Pneumatic time delay on page 156 |
| 3 | Pneumatic horn on page 158 |

The occupiable space protection kit is comprised of components that give personnel within the extinguishing zone both warning and egress time to evacuate the area. The occupiable space protection kit is comprised of adapters for connecting the kit to a pilot cylinder, pressure reducer, pneumatic time delay, and pneumatic horn. For details on each component, refer to the sections referenced in Figure 9.21 on page 155.

Adapter and pressure reducer

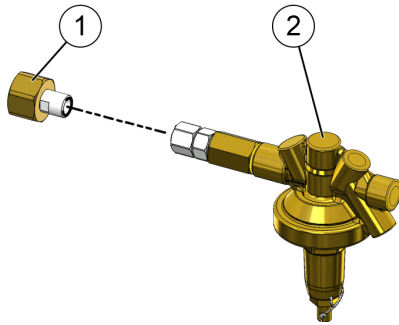

Figure 9.22: Adapter and pressure reducer

1	From pilot tank	2	Pressure reducer
---	-----------------	---	------------------

The adapter converts valve thread pilot line connections.

Pneumatic time delay

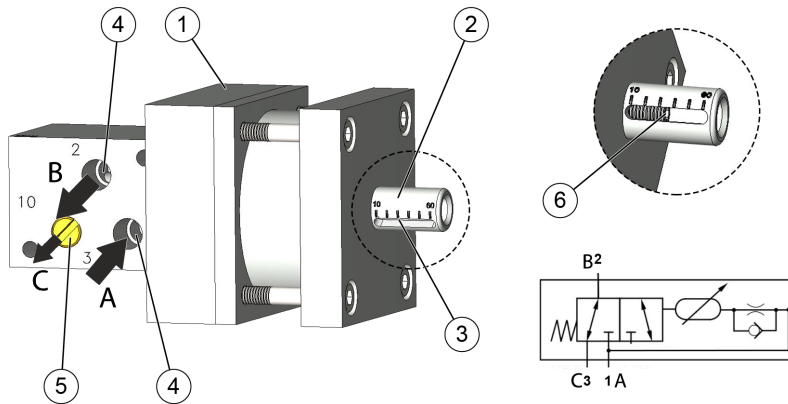

Figure 9.23: Pneumatic time delay

1	3/2- way piston slide valve	4	Threaded connection G1/8
2	Delay time setting range	5	Silencer
3	Adjusting spindle	6	30 second factory-set delay time

A - Pressure connection, incoming from the pressure reducer for the nitrogen pilot cylinder (connection "A" is marked on the time delay unit and in the circuit symbol with [1]).

B - Operating connection, outgoing to the extinguishing agent container battery/ extinguishing agent containers (connection "B" is marked on the time delay unit and in the circuit symbol with [2]).

C - Venting with sinter filter/silencer (connection "C" is marked on the time delay unit and in the circuit symbol with [3]).

The delay time can be set from 10 to 60 seconds (7 to 55.5 seconds in accordance with FM/UL requirements). The delay time is set to 30 seconds at the factory. The adjusting spindle has been secured with sealing wax.

In a ready state, the non-electrical time delay unit is closed and not supplied with control gas. The pilot line at operating connection "B" is kept depressurized via venting "C". This stops the build up of pressure in the pilot line and prevents the faulty release of extinguishing agent.

After detecting a fire in an extinguishing zone and once a fire extinguishing signal has been given by the electric control device/SRP, the pilot cylinder is opened electrically without delay. A pressure reducer lowers the control gas to a pressure of 152 psi (10.5 bar).

This provides the control pressure at pressurized connection "A" which is internally connected to the control input. The time delayed release of the working pressure at operating connection "B" is achieved by filling a chamber via the control input through a defined overflow channel. Once the predefined pressure in the chamber has been achieved, the piston slide valve is actuated and the control pressure is released via operating connection "B".

The delay time is set by increasing or reducing the chamber volume using a hexagon socket wrench.

Once the control pressure is withdrawn, the time delay unit immediately and automatically switches back to an idle state.

During the delay time, flooding of the extinguishing zone can be prevented only by an optional stop valve.

Pneumatic horn

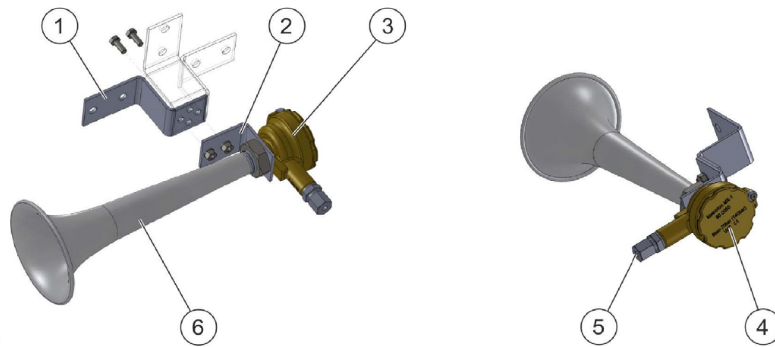

Figure 9.24: Pneumatic horn

1	Large fastening bracket	5	Pneumatic pilot line connection
2	Small fastening bracket	6	Horn
3	Housing		
4	Marking		

The pneumatic horn is a pneumatically operated alarm device that is used in gas extinguishing systems for life safety. Membranes in the makrofon are made to vibrate as a result of pressurization with gas. This generates a sound at a constant frequency. This sound is amplified by the horn so that a sound pressure level of approx. 100dB(A) to 125dB(A) is reached depending on the pressure.

Noise emissions

The pneumatic horn (makrofon) emits a sound when activated at a level of approximately 106 dB(A). This value is based on measurements in a laboratory with CO₂ and IG-100. The actual value may differ due to local acoustic properties.

9.15 Pilot Cylinder



Figure 9.25: Pilot cylinder with Unistrut racking

1	Protective cap
2	Outlet venting safety plug
3	Pilot cylinder
4	Unistrut racking

Nitrogen (N_2) is stored as control gas in pilot cylinders with a volume of 80 or 30 l (21.13 or 7.92 gal).

A label is attached to each pilot cylinder. For safety reasons, all pilot cylinders must be mounted on stable building elements (e.g. a wall).

Pilot cylinders may not be moved and transported unless fitted with a protective valve cap and outlet venting safety plug on the valve output. Filled pilot cylinders must be labeled and transported as hazardous material in accordance with all applicable local guidelines.

9.16 Shuttle non-return valve

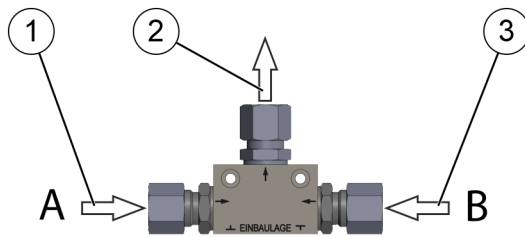

Figure 9.26: Shuttle non-return valve

1	Inlet "A"
2	Outlet
3	Inlet "B"

The shuttle non-return valve enables the differentiated triggering of a pneumatic assembly/components through two pressure sources.

By pressure at inlet "A", inlet "B" is closed, and there is a passage from inlet "A" to the outlet.

By pressure at inlet "B", inlet "A" is closed, and there is a passage from inlet "B" to the outlet.

9.17 Pilot pressure relief assemblies

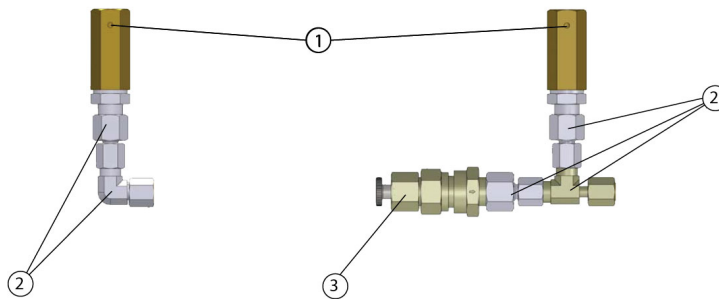

Figure 9.27: Pilot pressure relief (part no. 24498) and automatic/manual assembly (part no. 24499)

1	Pilot pressure relief device
2	Union
3	Push button pressure relief

The pilot pressure relief device is used to prevent an unintentional pressure buildup in pneumatic pilot lines due to leakage.

The pilot pressure relief device is used on the quick release valve to prevent the extinguishing agent containers from being incorrectly activated by such an unintentional pressure build-up.

After an activation, the push button pressure relief is used to manually relieve pressure from pneumatic pilot lines without having to disassemble them.



The pilot pressure relief device can only be assembled vertically (pointing upwards) as shown in Figure 9.27 on page 161.



For more information, observe the documentation for the pilot pressure relief device.

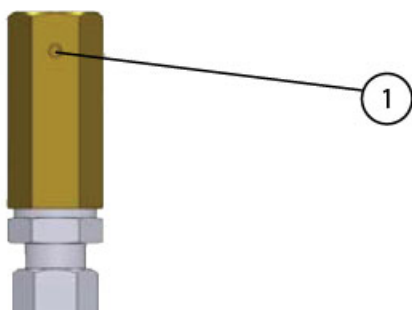

Figure 9.28: Pilot pressure relief device

1	Relief bore
---	-------------

The pilot pressure relief device enables the discharge of small leaks in pneumatic pilot lines using a relief bore. The pilot pressure relief device closes automatically at high pressures.

9.18 Multi-zone Control Unit MZ-1

The control unit is a modular system within a fire extinguishing system and is used for triggering extinguishing zones and the accompanying zone quantities. The modular system enables the zone quantities to be adjusted for each extinguishing zone. A maximum of 10 extinguishing zones can be triggered with the accompanying 5 tank zone quantities.

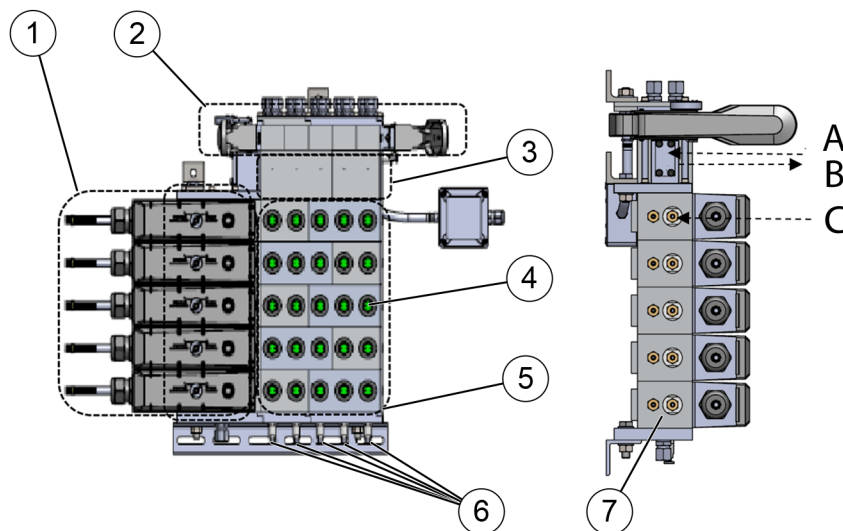

Figure 9.29: Control unit MZ-1

1	Electrical control module	6	Pressure relief devices
2	Main/reserve change-over	7	Control module
3	Release module	A&B	Connections for time delay device on connection module
4	Check valve (green: open; red: closed)	C	Selector valve/pneumatic horn pilot line connection
5	Quantity module		

When a signal has been received, the release control panel electrically triggers the pilot cylinder and the activated zone's electrical control module in the control unit. Control gas from the pilot cylinder then reaches the control unit via pilot lines. The resulting control pressure is displayed for all control modules. This gas flows through the control

module opened by the release control panel. All other control modules remain closed, so only the activated extinguishing zone is flooded.

As the control gas flows towards the activated extinguishing zone, it activates the selector valve and pneumatic horns for that zone. When these two devices are activated, the zone quantity for the extinguishing zone is triggered at the same time. The quantity of gas released is regulated by check valves that are either placed in the closed or open position by the quantity module, so only the appropriate amount of gas is used.

As these check valves are triggered by the quantity module, the check valve in the control module activates the release module. A time delay device can optionally be inserted between the control module and the release module to delay triggering of the extinguishing cylinder.

After a fire, the use of the main/reserve change-over means that the fire extinguishing system can be immediately put back into service and is protected by means of the reserve cylinders.

9.19 Lock Out Device, Pilot Line

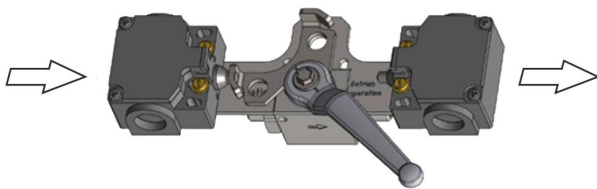

Figure 9.30: Lock out device

The lock out device is a non-electrical disable device for disabling fire extinguishing systems. It prevents the extinguishing agent from flowing out into the extinguishing zone.

If it is necessary to carry out repair or servicing work in the protection zone that could lead to the accidental activation of the fire extinguishing system or prevent exit from the rooms within the pre-warning time, the fire extinguishing system must be blocked.

The ball valve makes it possible to shut off the pilot line. At the same time, the shut-off vents the onward pilot line to prevent an accidental pressure increase due to leakage.

A limit switch is be installed to monitor the inactive and blocked states.

9.20 System Piping

All system piping must conform to NFPA 2001. Refer to FSSA pipe design handbook or similar guides for reference.

9.21 Pneumatic Limit Switch

The pneumatic limit switch allows you to evaluate whether an extinguishing zone has actually been flooded after the selector valve is actuated. In PR systems, the pneumatic limit switch must be installed after the pressure reducer in the low pressure pipe network. For CF systems, the pneumatic limit switch can be located anywhere in the pipe network. The extinguishing agent pressure activates the cylinder, which opens or closes the floating contacts of the limit switch.

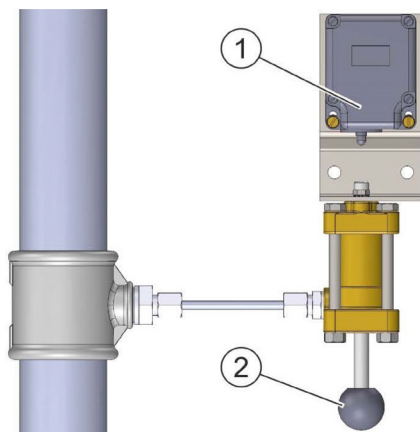

Figure 9.31: Pneumatic limit switch (part no. 826758D)

- | | |
|---|-------------------------------------|
| 1 | Pneumatically operated limit switch |
| 2 | Push button |

This allows signals that can be used for various purposes to be triggered via the limit switch if it is electrically connected to the release control panel. For instance, they can also be used to alert the fire department.

An additional push button allows you to trigger the electrical signal for test purposes.

9.22 Nozzles

9.22.1 VN Nozzle

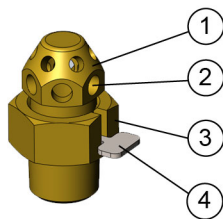

Figure 9.32: VN Nozzle

1	Nozzle head
2	Nozzle bores
3	Nozzle socket
4	Orifice

The nozzle consists of a nozzle socket, a nozzle head and an orifice with a calculated orifice diameter. All components sold as a singular unit.

During activation, the extinguishing agent flows through the nozzle, expanding once it exits the nozzle bores.



Two versions of the VN nozzle are available:

- **360° for assembly in the middle of the room**
- **180° for assembly near walls**

9.22.2 DCM Nozzle (PR systems only)



Figure 9.33: DCM Nozzle

During activation, the extinguishing agent flows through the nozzle, expanding evenly once it exits through the nozzle orifice.

The nozzle is provided with threads on the inlet and outlet sides to enable mounting of the nozzle from the outside. Designed for use in particulate-dense applications such as bag houses, dust collectors, and machining centers.

9.22.3 Design concentration data

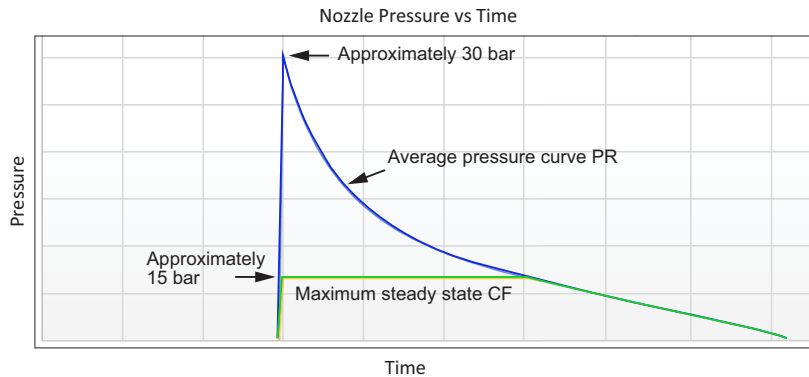

Figure 9.34: Pressure Reducing and Constant Flow discharge curves

Please note that the minimum nozzle pressure in the following tables are the minimum nozzle pressures obtained over a full discharge as defined by NFPA 2001. vInert or DesignManager will output the maximum nozzle pressure over a full discharge as defined by NFPA 2001. The minimum nozzle pressure is not included in vInert's or DesignManager's printouts. The calculation engine ensures that the nozzle pressure is never lower than the minimum stated in the tables.

Table 9-5: Verified Pressure Reducing system limits for 360° style VN nozzles and 180° style VN nozzles with IG-100 (nitrogen)

Nitrogen (IG-100)	Nozzles VN 360°	Nozzles VN 180°
Nozzle coverage area	26.3 ft x 26.3 ft (8.0 m x 8.0 m)	34.8 ft x 34.8 ft (10.6 m x 10.6 m)
Maximum height	20.51 ft (6.25 m)	20.51 ft (6.25 m)
Minimum height	0.98 ft (0.30 m)	0.98 ft (0.30 m)
Minimum nozzle pressure	388.7 psi	396.0 psi
Design concentration, Class A*	37.98 vol.-%	37.98 vol.-%
Design concentration, Class B*	42.38 vol.-%	42.38 vol.-%
Design concentration, Class C*	42.73 vol.-%	42.73 vol.-%
*According to NFPA 2001, UL 2127, and FM 5600		

Table 9-6: Verified Constant Flow system limits for 360° style VN nozzles and 180° style VN nozzles with IG-100 (nitrogen)

Nitrogen (IG-100)	Nozzles VN 360°	Nozzles VN 180°
Nozzle coverage area	26.3 ft x 26.3 ft (8.0 m x 8.0 m)	26.3 ft x 26.3 ft (8.0 m x 8.0 m)
Maximum height	20.51 ft (6.25 m)	20.51 ft (6.25 m)
Minimum height	0.98 ft (0.30 m)	0.98 ft (0.30 m)
Minimum nozzle pressure	59.4 psi	201.6 psi
Design concentration, Class A*	35.4 vol.-%	33.48 vol.-%
Design concentration, Class B*	42.77 vol.-%	42.38 vol.-%
Design concentration, Class C*	39.83 vol.-%	37.67 vol.-%
*According to NFPA 2001, UL 2127, and FM 5600		

Table 9-7: Verified Pressure Reducing system limits for 360° style VN nozzles and 180° style VN nozzles with IG-01 (argon)

Argon (IG-01)	Nozzles VN 360° and Nozzles VN 180°	
Nozzle coverage area	26.3 ft x 26.3 ft** (8.0 m x 8.0 m)	34.8 ft x 34.8 ft*** (10.6 m x 10.6 m)
Maximum height	20.51 ft (6.25 m)	20.51 ft (6.25 m)
Minimum height	0.98 ft (0.30 m)	0.98 ft (0.30 m)
Minimum nozzle pressure	432.2 psi	449.6 psi
Design concentration, Class A*	49.31 vol.-%	52.52 vol.-%
Design concentration, Class B*	57.98 vol.-%	61.75 vol.-%
Design concentration, Class C*	55.48 vol.-%	59.09 vol.-%
*According to NFPA 2001, UL 2127, and FM 5600		
**Indicated as short throw in Class B fuel MDC tables		
***Indicated as long throw in Class B fuel MDC tables		

Note that the 180 and 360 degree VN nozzles for argon PR systems are approved to two different coverage areas. Both columns (in the table above only) apply to both nozzle types.

Table 9-8: Verified Constant Flow system limits for 360° style VN nozzles and 180° style VN nozzles with IG-01 (argon)

Argon (IG-01)	Nozzles VN 360°	Nozzles VN 180°
Nozzle coverage area	26.3 ft x 26.3 ft (8.0 m x 8.0 m)	26.3 ft x 26.3 ft (8.0 m x 8.0 m)
Maximum height	20.51 ft (6.25 m)	20.51 ft (6.25 m)
Minimum height	0.98 ft (0.30 m)	0.98 ft (0.30 m)
Minimum nozzle pressure	104.4 psi	156.6 psi
Design concentration, Class A*	46.44 vol.-%	46.32 vol.-%
Design concentration, Class B*	55.13 vol.-%	55.12 vol.-%
Design concentration, Class C*	57.25 vol.-%	57.25 vol.-%
*According to NFPA 2001, UL 2127, and FM 5600		

Table 9-9: Class B fuel MDC Values

Fuel	VN Nozzle	VN Nozzle Short Throw	VN Nozzle Long Throw	DCM Nozzle		Constant Flow	
	IG-100	IG-01	IG-01	IG-100	IG-01	IG-100	IG-01
Acetone	42.4	57.9	64.8	48.9	56.2	43.0	56.2
Acetonitrile	42.4	57.9	64.8	48.9	56.2	43.0	56.2
Aviation gas	42.4	57.9	64.8	48.9	56.2	43.0	56.2
Benzene	42.4	57.9	64.8	48.9	56.2	43.0	56.2
Diesel no. 2	42.9	58.6	65.6	49.5	56.8	43.6	56.8
Ethane	42.9	58.6	65.6	49.5	56.8	43.6	56.8
Ethyl acetate	43.6	59.5	66.6	50.3	57.7	44.2	57.7
Ethyl alcohol	51.9	70.9	79.4	59.9	68.8	52.7	68.8
Ethylene glycol	48.6	66.5	74.4	56.1	64.5	49.4	64.5
Gasoline - no lead	44.2	60.3	67.5	51.0	58.5	44.9	58.5
Heptane, commercial	42.4	57.9	64.8	48.9	56.2	43.0	56.2
i-Octane	42.4	57.9	64.8	48.9	56.2	43.0	56.2
i-Propyl alcohol	48.0	65.5	73.4	55.4	63.6	48.7	63.6
Kerosene	44.2	60.3	67.5	51.0	58.5	44.9	58.5
Lube oil at 500 °F	45.5	62.0	69.5	52.5	60.2	46.2	60.2
Methane	42.4	57.9	64.8	48.9	56.2	43.0	56.2
Methyl alcohol	62.1	84.8	95.0	71.7	82.3	63.1	82.3
Methyl isobutyl ketone	44.9	61.2	68.6	51.8	59.4	45.5	59.4
Morpholine	50.6	69.1	77.4	58.4	67.1	51.3	67.1
n-Butane	42.4	57.9	64.8	48.9	56.2	43.0	56.2
n-Heptane	42.4	57.9	64.8	48.9	56.2	43.0	56.2
n-Hexane	42.9	58.6	65.6	49.5	56.8	43.6	56.8
n-Octane	43.6	59.5	66.6	50.3	57.7	44.2	57.7
n-Pentane	42.4	57.9	64.8	48.9	56.2	43.0	56.2
n-Propyl alcohol	49.3	67.3	75.3	56.9	65.3	50.0	65.3
Propane	42.9	58.6	65.6	49.5	56.8	43.6	56.8
Tetrahydrofuran	47.3	64.7	72.5	54.6	62.8	48.0	62.8
Toluene	42.4	57.9	64.8	48.9	56.2	43.0	56.2
Transformer oil	44.9	61.2	68.6	51.8	59.4	45.5	59.4
Xylene	42.4	57.9	64.8	48.9	56.2	43.0	56.2

9.23 Overview of System Limits

9.23.1 System limits according to UL/FM approval

Details on the maximum permissible number of release devices and the maximum permissible line lengths for pneumatic actuation are as follows:

Table 9-10: System Limits

Actuation type	Maximum permissible number of pneumatic release devices	Maximum pilot line length
Primary cylinder to secondary connection of valve	102	236 ft (72 m)

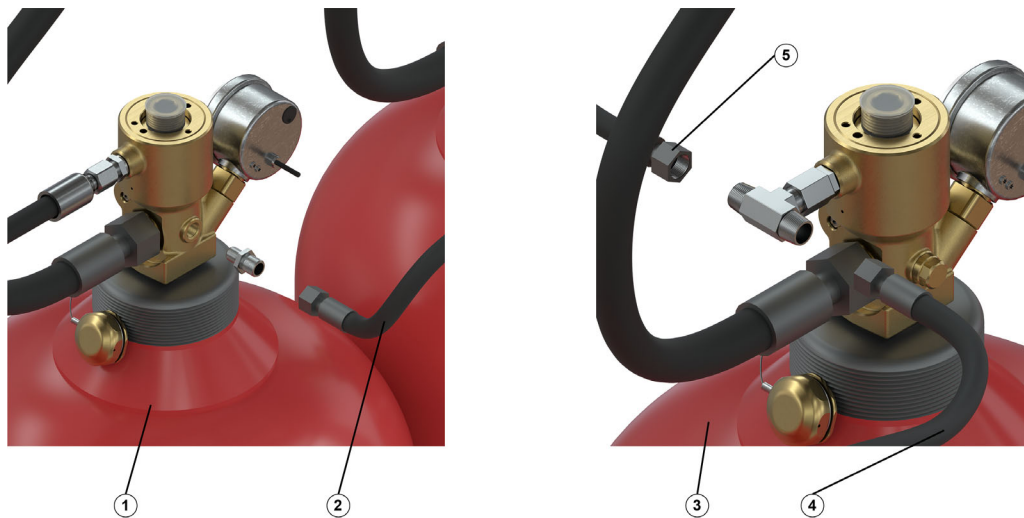

Figure 9.35: Example of pilot connection between cylinders

1	Primary cylinder	4	From primary cylinder
2	To secondary cylinder	5	To next secondary cylinder
3	Secondary cylinder		

9.24 Resetting System Isolation in the Event of Fire

Personnel:

- Person in charge of the system

Protective equipment:

- Safety gloves
- Safety footwear

After a discharge, remove all electrical actuators and close all lock out valves installed prior to resetting the control panel. Ensure all electrical actuators are reset before reinstalling.



CAUTION

Failure to reset the electrical actuator before reinstalling onto the tank may result in system discharge.



Once the panel is reset, ensure no detectors are in an alarm state. If any detectors are in an alarmed state, the system will discharge again.

While the system is disabled, change the system supply to the reserve bank, or resupply the cylinders from your primary bank.

Once the cylinder supply has been replenished, reinstall the electrical actuators to the proper cylinders.

9.25 Types of System Activation

Personnel:

- Person in charge of the system

Protective equipment:

- Safety gloves
- Safety footwear

The system is activated automatically by fire alarm systems installed in the protected enclosure. Other options to activate the system manually vary with the design of the system.

- Electric manual release at the extinguishing zone
- Manual activation at the primary extinguishing agent container or the pilot cylinder

Example of potential sequence of events after activation

These steps are shown only as an example and may change depending on local regulations and guidance from the AHJ.

1. If one or several fire alarm devices, the fire detection system, or a manual release are activated, the alarm will be transmitted to the fire suppression releasing panel.
2. A signal will sound on the fire suppression detection system.
3. All connected, central ventilation, and air conditioning units as well as any other devices (for example the power supply) will be switched off. Fireproof doors and windows equipped with automatic locking mechanisms will be locked.
4. The alarms will be activated.
5. The set pre-discharge timer will start counting down.
6. When the pre-discharge timer has run out, the valves of the extinguishing agent containers will open and the agent will flow through the system piping to the discharge nozzles.
7. At the extinguishing nozzles, the extinguishing agent flows out and is emitted evenly in the extinguishing zone.
8. The hold time of the extinguishing agent, during which its effective concentration for suppressing fires is retained, will start counting down.

i If the system is activated by pneumatic/manual triggering devices or manual triggering devices, the activation will be immediate without any visual or acoustic alarm equipment.

Pre-discharge timer

The pre-discharge timer is the time between the release of the main alarm and the beginning of the fire extinguishing process. It is usually set to 30-45 seconds.

All persons within the affected extinguishing zone must leave within this period and lock all non-automatic access doors and windows in the extinguishing zone.

9.25.1 Activating the system with the manual release device

If manual release is necessary, proceed with evacuation and activate the manual release device while egressing. If installed, the manual release device will be located near an exit

1. Evacuate the extinguishing zone of personnel.



Figure 9.36: Activating the manual release device

- | | |
|---|------------|
| 1 | Safety pin |
| 2 | Hand lever |

2. Pull the safety pin out of the manual release device on the primary extinguishing agent container.
3. Press the hand lever downward until it stops.



The manual releasing process takes at least 5 seconds.

4. Immediately leave the extinguishing zone
 - The system will be activated immediately.

9.26 Actions After the System is Activated

Safety considerations



WARNING

Risk of death due to oxygen shortage and combustion gases.

The oxygen content in the extinguishing zone is heavily reduced during the extinguishing process. Combustion gases may also be present. A risk of asphyxiation exists.

- Enter the extinguishing zone only with atmosphere-independent breathing equipment.
- Do not re-enter the affected rooms until the fire department has given the all-clear.
- Follow the instructions given by the rescue workers.



WARNING

Risk of death from re-ignition.

When the effective concentration of the extinguishing agent drops due to the ventilation of the extinguishing zone, the fire may be reignited by any sources of ignition that may still exist. There is a risk of sustaining severe or fatal injuries.

- Do not re-enter the affected rooms until the fire department has given the all-clear.
- Be prepared for re-ignition at all times. Keep suitable extinguishing agents (e.g. fire extinguishers) on hand when ventilating the extinguishing zone.

Steps to be taken after a fire has occurred

Personnel:

- Person in charge of the system

Protective equipment:

- Self-contained breathing apparatus
1. Do not re-enter or clear access points to the affected rooms until the fire department has given the all-clear.

2. Enter the extinguishing zone under the supervision of the fire department and open windows and doors.
3. Keep an eye on the fire sources that have been put out.
4. Notify the installing contractor or appropriate service personnel so that the operational readiness of the system can be restored.
5. Perform function checks.

Steps after faulty release

Personnel:

- Person in charge of the system

Protective equipment:

- Self-contained breathing apparatus

The fire department must ensure that a sufficient concentration of oxygen exists in the extinguishing zones.



In addition to the instructions specified below, all applicable local regulations regarding response in the event of a system activation must be observed.

1. Make sure that no unauthorized persons can enter the affected premises before they have been cleared for access by the person in charge of the system.



For premises without sufficient ventilation, have the extinguishing agent extracted by the fire department.

2. Do not clear the extinguishing zone for access until it has been sufficiently ventilated and an oxygen concentration of at least 20.9% has been reached.
3. Notify the installing contractor or appropriate service personnel so that the operational readiness of the system can be restored.
4. Perform function checks.

9.27 Main/reserve Change-over

Personnel:

- Person in charge of the system

Protective equipment:

- Safety gloves
- Safety footwear

Ensure electric actuators are reset and the system is isolated (reuse the warnings from earlier section).



The replacement of extinguishing agent containers may only be performed by the installer or service personnel authorized by the installing contractor.

9.27.1 Main reserve change-over with electronic key switch

1. Ensure electric actuators are reset and that the system is isolated.
2. Insert and turn the key in the electronic key switch. Visual indication of the switch from the main cylinder bank and the reserve bank will be apparent.

9.27.2 Main reserve change-over with the MZ-1

1. Remove the locking pin from the MZ-1.
2. Switch the panels on the top of the MZ-1 from “main” to “reserve.”
3. Replace the locking pin.



DANGER

Risk of accidents due to heavy pressurized containers.

Extinguishing agent containers are very heavy and may be pressurized. If handled improperly, they can pose a life-threatening hazard.

- **Always handle extinguishing agent containers with at least 2 people.**
- **Always use suitable means of transport.**
- **Immediately secure the valve outlet with an outlet venting safety plug and the valve with a protective valve cap.**
- **Wear safety gloves, safety footwear, protective goggles and hearing protection.**

10 Inspection, Servicing, and Cleaning

i All service intervals shall be in accordance with NFPA 2001 and manufacturer recommendations.

i Allow only an installing contractor or appropriate service personnel to perform any servicing and repairs on the system.

WARNING

Danger due to faulty servicing and repair

Errors occurring during servicing and repair may lead to life-threatening situations and cause significant property damage.

- **Allow only the servicing contractor or appropriate service personnel to perform maintenance and repair.**
- **Avoid any unauthorized servicing and repair of all system components.**

Personnel:

- Servicing contractor

Protective equipment:

- Industrial hard hat
- Safety goggles
- Safety gloves
- Safety footwear

WARNING**Risk of death due to missing fire protection**

There is limited or no fire protection when decommissioning the system. Fires can cause serious injury or even death and substantial property damage.

- Keep fully functional substitute fire extinguishing agent (e.g. fire extinguisher) at hand.
- Do not decommission the system any longer than necessary.
- Recommission the system immediately after carrying out the servicing work.

WARNING**Risk of injury due to improperly executed maintenance work**

Improper maintenance can cause serious injury and substantial property damage.

- Prior to commencing work, make sure there is sufficient space for performing servicing work.
- Make sure the installation site is tidy and clean! Components and tools that are laying around loosely or on top of each other pose a potential source of accidents.
- If components were replaced, carry out the installation according to the specifications in this service manual.
- Make sure that all servicing work is only carried out by appropriately qualified personnel.

Alarm caused by functional testing



The alarm devices are activated as part of the functional tests. When the signaling devices sound, this does not mean that there is an alarm situation. Inform personnel working in the system area about possible false alarms before commencing work.

Maintenance interval

The activities listed below must be carried out at least annually.

If different local laws, regulations or guidelines demand shorter maintenance intervals, these must be adhered to. If there are special environmental conditions, e.g. corrosive atmosphere, increased dirt load, or extreme temperature fluctuations, shorter maintenance intervals may be required.

Shorter service intervals, which can be prescribed for fire alarms, for example, do not apply to this fire extinguishing system.

This chapter only describes visual checks, functional tests, and manual releases or resets. The numbered listed in “Inspection” on page 189 is based on the activities to be carried out as per the service and maintenance log in which the servicing tasks must be documented. See “Inspection” on page 189.

Functional tests can usually be carried out per extinguishing zone so that all components are actuated at least once.

Comprehensive servicing includes the following steps in addition to the full system test:

- proper log-in/log-off of work with the operator
- checking of the system specifics and comparison against the log book
- confirmation of the work and the operational state of the system by an authorized signatory of the operator
- documentation of changes/repairs as requested by the operator



In the event of a claim, undocumented deviations from regular maintenance may represent a high risk with regard to liability. For this reason, precise documentation throughout the life cycle of the system is a prerequisite, in the log book as well as in the service log.

Table 10-1: Class B fuel MDC values

Designation	Visual check	Functional test	Manual release or reset
Support frame for extinguishing agent containers	x		
Manifold with high pressure system piping	x		
Extinguishing agent containers (main and reserve)	x		
Malfunction pressure safety device SFD 300	x		
Time delay unit TDU-10 u	x	x	
MZ-1 - triggering of pneumatic activation elements		x	
MZ-1 - disable device		x	x
MZ-1 - main/reserve change-over		x	x
MZ-1 - electrical control module		x	
Nozzle VN	x		
Low pressure system piping	x		
Pneumatic alarm device (makrofon)		x	
Limit switch, pneumatically operated		x	
Safety valve	x		
Selector valve		x	x
Pilot cylinders (main and reserve)	x		
Pneumatic pilot line	x		

10.1 Inspection and Maintenance Schedule

All inspection and maintenance tasks that must be executed on the system are described in the following chapters. Execute the tasks listed in the specified intervals, unless locally applicable regulations require different intervals.



In the event of a claim, undocumented deviations from regular maintenance may represent a high risk with regard to liability. For this reason, seamless documentation throughout the life cycle of the complete system is a prerequisite, in the log book as well as in the service log.

Table 10-2: Inspection and Maintenance Schedule

Interval	Maintenance work	Personnel
Weekly	Inspection and checks detailed in this manual	Person in charge of the system
Every 6 months	Inspecting the extinguishing agent containers <ul style="list-style-type: none"> • Amount filled • Fill pressure 	Qualified specialist personnel

Table 10-2: Inspection and Maintenance Schedule

Annually	Checking the protection zone for structural modifications <ul style="list-style-type: none"> • Dimensions • Usage • Fire loads 	Inspection personnel
	Checking the protection zone for leak tightness <ul style="list-style-type: none"> • Automatic locking systems • Devices that prevent accidental opening 	Inspection personnel
	Checking documentation and marking <ul style="list-style-type: none"> • Log book • Operating manual • System marking • Markings in the protection zone (for escape routes, etc.) 	Inspection personnel
	Checking activation and shut-off for alarms with a manual release	Inspection personnel
	Checking activation and shut-off for alarms with an automatic fire detector	Inspection personnel
	Checking alarm transmission	Inspection personnel
	Checking electrical release solenoids	Inspection personnel
	Checking pneumatic release devices (if applicable) <ul style="list-style-type: none"> • Activation by the pilot cylinder • Activation by the pneumatic release device 	Inspection personnel
	Checking manual release devices	Inspection personnel

Table 10-2: Inspection and Maintenance Schedule

Annually	Checking components for damage and checking for proper functioning <ul style="list-style-type: none"> • Valves • Selector valves • Hoses • Check valves • etc. 	Inspection personnel
	Inspecting the extinguishing agent containers <ul style="list-style-type: none"> • Condition • Mounting • Function of the supervised pressure gauges 	Inspection personnel
	Visually checking pipelines and discharge nozzles	Inspection personnel
	Checking the fire detection and extinguishing control panel <ul style="list-style-type: none"> • Condition • Proper connection • Electrical connections including equipotential bonding 	Inspection personnel
	Checking additional components <ul style="list-style-type: none"> • Fire detectors • Pressure relief devices • Alarm devices • etc. 	Inspection personnel
Every 5 years	Replace hoses Documentation of the hoses NOTE: Hoses can be re-qualified if they pass a pressure test.	Inspection personnel

i In addition, maintain components that are subject to wear (e.g. hoses, etc.) in accordance with the applicable local regulations.

Check extinguishing agent containers

i Check extinguishing agent containers in accordance with locally applicable regulations. Have visibly damaged or corroded extinguishing agent containers checked without delay and replace them with new containers, if necessary.

10.1.1 Maintenance of the control unit MZ-1

Inspection

Table 10-3: Inspection

	Quarterly inspection	Half-yearly inspection
Visually inspect for external damage and contamination	x	x
Carry out a functional test	--	x

General checks

The following points must be carried out during maintenance:

1. Check for damage, corrosion, and contamination.
 - Remove contamination.
 - If the control unit shows damage or corrosion, it must be replaced.



Cleaning agents that attack plastics, rubber, or metals must not be used under any circumstances.

2. Check all pilot line conduits and connections for tightness.
3. Check wall support screws for tightness.
 - If necessary, tighten using a suitable wrench.
4. Check whether the system moves.
 - Switch the disable device manually and alternately between both positions.
 - It must be possible to switch the disable device without excess force.
5. Compare the status of the disable device with the display on the fire alarm control panel.
6. Optionally, compare the status of the main/reserve change-over with the display on the fire alarm control panel.

10.1.2 Weekly inspections

Table 10-4: Weekly Inspections

Specification	Yes	NO
Do the supervised pressure gauges show system pressure? At 59 °F (15 °C) the pressure is 2901 psi (200 bar) or 4351 psi (300 bar) depending on the system.		
Have all extinguishing cylinders been fitted with the intended release devices?		
Ensure that the extinguishing cylinders are attached correctly.		
Do the extinguishing cylinders contain the required quantity - including any potential reserve quantities - in accordance with the installation certificate?		
Are the extinguishing cylinders, valves, release devices, hoses, selector valves, non-return valve, and pneumatic pilot lines in good condition?		
Are the electric lines leading to the SRP and the equipotential bonding connected properly and in good condition?		
Are the pipe systems components, supports, and extinguishing nozzles intact?		
Are the alarm devices intact?		
Are the manual releases accessible and in good condition?		
Are the automatic fire detectors intact?		
Are the extinguishing nozzle discharge zones unobstructed?		
Are all wall breakthroughs sealed off to the adjoining zones?		
Specification	Yes	NO
Are the pressure relief devices closed?		
Are the flow opening of the pressure relief devices unobstructed?		
Are all structural openings (e.g. windows, doors) closed or fitted with operational automatic locking devices?		
Are the means of escape of the protection zones unobstructed?		
Are additional fire loads (e.g. boxes, packaging material) removed from the protection zone?		
Are all information signs present and easily readable?		
Does the SRP show power supply voltage?		
Is no malfunction displayed on the SRP?		



If any of these inspection questions cannot be answered with “Yes” or if you are uncertain on the answer, please contact an installing contractor immediately.

10.2 Service Report

A service report must be kept concerning the execution of the inspection and maintenance tasks. The following applies in this regard:

- Log execution of all inspection and maintenance tasks in the service report.
- Note damaged or non-functioning parts in the service report.
- Have the service report countersigned after conclusion of the tasks by the person in charge of the system.
- Give a copy of the service report to the person in charge of the system.

10.3 Activities Before Servicing

In advance

Servicing must be announced in advance and prepared for:

- Inform the operator of the pending servicing in advance.
- Inform the operator that the automatic relaying of alarms must be deactivated for the time of the servicing.
- Obtain information on incidents (fires, malfunctions, conversions, spatial changes and changes in use, etc.).
- Inform the operator of the necessity of access to the affected facilities.

On the day of servicing

- Inform the operator's person in charge of the system that the system servicing will take place and that due to the servicing, alarm and error messages as well as function interruptions can occur.
- Ensure that the departments where the alarms and malfunctions are automatically detected have been informed of the tasks that will be performed on the system and that the automatic relaying of alarms has been deactivated.
- Keep reserve extinguishing equipment on hand (e.g. fire extinguishers).
- Take the system out of service before starting service tasks:

- - Secure extinguishing agent containers against faulty release (e.g. unscrew all the release devices from the extinguishing agent containers or remove the pilot lines depending on the valve type).
 - - Secure the pilot cylinder against faulty release.
- Carry out service tasks and acknowledge their execution in a service report.

10.4 Taking the System Out of Service

1. Remove all electrical release solenoids from the pilot cylinders.
2. Disconnect the pneumatic pilot lines to all extinguishing agent containers.

10.5 Visual inspections

10.5.1 General visual inspections

1. Check the components visually for external damage, corrosion, cracks, contamination, completeness of all components, and correct assembly.
2. Remove surface contamination with a cloth.



Cleaning agents that attack plastics, rubber, or metals must not be used under any circumstances.

3. Replace damaged, corroded, cracked or leaky components immediately.
4. Check the tightness of all unions that do not contain security paint. If security paint is broken, contact the manufacturer.

10.5.2 Checking the fire suppression system center visually

1. Check that the documentation is available at the control panel.
2. Check that the installer sign is present and in a clearly legible condition.
3. Check whether the room temperature is within the designated temperature range
4. Check that the markings and warning signs are present and are in a clearly legible condition.
5. Check that the fire extinguishing system control panel is secured against unauthorized access.
6. Check that the lighting is intact and adequate.

7. Check that no objects are stored in the fire extinguishing system control panel and that the panel is not exposed to any damaging environmental influences.
8. Check that the labels of the components are present and in clearly legible condition and that the emergency service sticker is up-to-date.
9. Check that the function of the system is not impaired by external installations or objects and that external installations or objects cannot cause a faulty release.
10. Check that the external condition of the extinguishing agent containers, hoses and fixings is free of faults.
11. Check that the pipeline is grounded and that the ground connection is mechanically intact.
12. Check the protective coating of the system parts and, if necessary, re-coat.
13. Check that the content of the extinguishing agent container is within the tolerances. Read the pressure gauges taking into account the room temperature and the temperature-pressure table; for example, see Figure 3.1 on page 46 and Figure 3.2 on page 47 (additional tables are available from the manufacturer).

10.5.3 Checking the selector valve station

Only for multi-zone systems:

1. Check the marking of the extinguishing zones and the labels for the selector valves are available and are in good legible condition.
2. Check the external condition of the valves (selector valve control, quantity control, selector valves) and their connection lines, connections, and supports.



The function of the selector valves must be tested during system commissioning.

10.5.4 Checking the extinguishing zones

1. Check whether the warning signs for each access door of the extinguishing zones are completely present and are in an easily readable condition.
2. Check whether the panic locks at the entrances are present and intact.
3. Check whether the optical and acoustic alarm devices are present and undamaged.

4. Check whether the manual release devices and, if necessary, the stop buttons are present and freely accessible.
5. Check whether the extinguishing zone is unaltered and undamaged.
6. Check whether the pressure relief devices or fire safety vents are unaltered and not blocked.
7. Check if the extinguishing pipe lines are free from corrosion and undamaged or misused.
8. Check that the extinguishing nozzles are free from contamination and are not obstructed in their discharge zone.
9. Check whether the extinguishing zone is free from dust pollution, especially in the discharge zone of the extinguishing nozzles.
10. Check and lubricate the door release units.
11. Check the closing functions of the doors.

10.6 Refilling

Personnel:

- Installing contractor

Protective equipment:

- Industrial hard hat
- Safety goggles
- Safety gloves
- Safety footwear

WARNING

Risk of injury due to pressure in extinguishing agent containers

If pressurized extinguishing agent containers are damaged and extinguishing agent escapes uncontrollably, there is a risk of severe injuries.

- **Do not transport or store extinguishing agent containers unless they are sealed with a protective valve cap and an outlet venting safety plug.**
- **Make sure that the extinguishing agent container on the filling unit is secured with the appropriate claw against tipping over. The latch must be closed.**
- **Replace damaged extinguishing agent containers immediately.**

Defective components cannot be repaired; they must be replaced with original spare parts.

i If the valve needs to be replaced due to corrosion, contamination or other damage, the seal ring between the extinguishing agent container and valve must also be replaced.

Preparing the extinguishing agent container

1. Clean and re-coat the extinguishing agent container, if needed.
2. If necessary, check the extinguishing agent container in accordance with the locally applicable pressurized device regulations.

Ventilation spacing requirements

Depending on local provisions and approvals, the filling service may need to be recognized by the authorities or a testing authority.

Filling and storage areas must be sufficiently ventilated to ensure that the maximum permissible extinguishing agent concentration (NOAEL) is not exceeded when the extinguishing agent is unintentionally released.

Contact Purity Cylinder Gases at (616) 532-2375 or www.puritygas.com for refilling information and services.

The measuring equipment used and its regular calibrations must comply with the locally applicable guidelines (e.g.NFPA 2001, ISO 17025).

i During the filling process, the pressure gauge attached to the extinguishing agent container must not be used to determine when the intended container pressure has been reached.

i A suitable pressure control must be used if the pressure source is a highly pressurized tank.

10.7 Cleaning

10.7.1 Warnings regarding the cleaning of the system

Faulty activation

WARNING

Risk of injury from faulty activation

Cleaning the surfaces of the system components may set off the system if too much dust is stirred up, too much manual pressure is exerted, or the release devices are activated by accident. This may result in injury and significant property damage.

- Always use caution when cleaning the component surfaces of the system.
- Clean the fire detection and release devices (e. g. electric manual releases, smoke detectors) as specified by their respective manufacturers.
- Avoid stirring up dust.

Cleaning agents

NOTICE

Property damage from abrasive cleaning agents

Acids and bases may cause significant property damage to the system and its components.

- Use only water (a damp cloth) to clean the surfaces of the components.
- Never clean the system using acids, bases or other cleaning agents containing acid.

Cleaning equipment

NOTICE

Property damage from wrong cleaning equipment

Wrong cleaning equipment may cause significant property damage to the system.

- **Use only a damp cloth to clean the surfaces of the components.**
- **Never use files, grinders or similar cleaning equipment that abrade material to remove residue and/or corrosive residue from the component surfaces.**

10.7.2 Cleaning the system

The owner of the system is responsible for maintaining and cleaning the system. The component surfaces of the system must be cleaned prior to every function check of the system (weekly) in order to allow for visual checks. Use a damp cloth to carefully remove dust and dirt deposits from all surfaces of the components. Report any corrosion damage and/or coating stuck on the component surfaces to the installing contractor.

11 Malfunctions

The following section describes possible causes for faults and the work required to correct these faults.

If faults occur frequently or cannot be remedied by following the instructions listed below, contact a company approved to install the system. Contact can be established through the manufacturer (see page 2).

11.1 Warnings Regarding Troubleshooting

Non-operational system

WARNING

Risk of death when system is not ready for operation

If the system experiences malfunctions, it may not be operational. Fires cannot be fought effectively and may lead to severe injuries including death as well as significant property damage.

- Correct malfunctions (or have malfunctions corrected) immediately.
- Check the system for proper operation before putting it back into service (See “Visual inspections” on page 189.)

Improperly performed troubleshooting operations

WARNING

Risk of injury from improper troubleshooting

Improperly performed troubleshooting operations may cause severe injuries and significant property damage.

- Have faults that cannot be remedied by following the instructions specified in this section corrected only by the installing contractor or the appropriate service personnel.

Procedure in case of a fault

The following always applies:

1. Determine cause of fault using the following fault table.
2. If a fault cannot be remedied by following the specified instructions, consult the installing contractor or the appropriate service personnel and have them correct the fault.
3. Notify the owner of all detected faults.

11.2 Fault Indicators

Possible malfunctions are indicated on the SRP.



This manual does not include a description of the SRP. Follow the separate instructions for use.

Other indications of malfunctions such as extinguishing agent leaks are provided by the supervised pressure gauge fitted on the extinguishing agent containers.

11.3 Malfunction Tables

Protective equipment:

- Industrial hard hat
- Safety goggles
- Safety gloves
- Safety footwear

11.3.1 Extinguishing agent container with quick release valve

Fault description	Cause	Remedy
The value indicated by the pressure gauge is too low or too high	The room temperature is too low or too high	Adjust the room air conditioning

Loss indication shown on the SRP	At least one extinguishing agent container is leaky	Identify the extinguishing agent container
		Replace the extinguishing agent container immediately
Line breakage or short circuit in the loss monitoring is shown on the SRP	Line or cable connection is faulty	Identify damaged area and repair it

11.3.2 Selector valve

Fault description	Cause	Remedy
The functional condition of the SRP does not match the position of the ball valve	The limit switch or actuation mechanism is defective	Check the installation position and actuation mechanism
		Replace the limit switch
The selector valve does not open or cannot be closed	The piston in the rotary drive is defect	Replace the selector valve
	The ball valve is blocked or stuck	Check the actuation force Check whether the selector valve is de-energized and correct if necessary

11.3.3 Manifold safety valve

Fault description	Cause	Remedy
The lead seal, tamper evident paint, or sealing wire is damaged	External influence, e.g. during the assembly or servicing	Replace the safety valve

11.3.4 Pneumatic control of the pilot cylinder

Fault description	Cause	Remedy
The value indicated on the supervised pressure gauge is too low or too high. Refer to section "Correct Supervised Pressure Gauge Display" on page 207 for more information.	The room temperature is too high or too low	Compare the value indicated with other pressure gauges
	Extinguishing agent loss is greater than 10%	Cool or heat the installation area Compare the indicated value with the temperature-pressure table Replace the extinguishing agent containers
The value indicated on the supervised pressure gauge is incorrect	The pressure gauge is defective	Compare the value indicated with other pressure gauges
	(See above)	Replace the pressure gauge
Loss indication signal on the fire control panel	Extinguishing agent loss is greater than 10%	Compare the indicated value with the temperature-pressure table
	(See above)	Replace the extinguishing agent containers

Fault description	Cause	Remedy
The trouble signal “loss indication” is shown	The line connection is faulty (short circuit or wire break)	Detect the faulty connection Perform repairs
The electrical release solenoid is not activated despite triggering (LED lights up)	The polarization of the electrical connection is incorrect	Check the cable connection and correct it
	The electrical release solenoid is defective	Replace the electrical release solenoid
	The connection line is inverted (commissioning)	Correct the connection
	The control module is defective (maintenance)	Replace the control module
The trouble signal “electrical release solenoid” is shown	The line connection is faulty (short circuit or wire break)	Detect the faulty connection Perform repairs
No pressure or the incorrect pressure is applied to the pressure reducer	A foreign object or dirt is blocking the inlet to the pressure reducer The pressure reducer is incorrectly set The pressure reducer is defective	Check the connection components (adapter, valve output); clean and remount if necessary Check and set the setting If the pressure reducer cannot be set, replace it

Fault description	Cause	Remedy
The adapter connection is leaky	The seal is defective or not present	Check the seal; replace if necessary
The shuttle non-return valve is leaky or not functioning	The seal fitting is dirty or the ball is stuck	Replace the shuttle non-return valve

11.3.5 Pneumatic time delay

Fault description	Cause	Remedy
Delay time is incorrect	Time setting is adjusted	Correct the time setting
	Incorrect test gas and/or incorrect test pressure set	Use nitrogen (N ₂) test gas at a test pressure of 109 psi (7.5 bar)
Pneumatic time delay unit does not function	Pneumatic pilot line to operating connection has a leak	Check the union and hose line; seal and replace if necessary
	Pneumatic pilot line to pressurized connection is depressurized	Check the pilot cylinder, pressure reducer, etc. and repair if necessary
Pilot pressure is not released	Valve does not open in spite of pneumatic actuation (valve defective or contaminated)	Replace time delay unit

11.3.6 Limit switch, pneumatically operated

Fault description	Cause	Remedy
Limit switch does not switch	Limit switch is misaligned	Readjust the limit switch
	Limit switch is defective	Replace the limit switch
	Pneumatic pilot line is faulty	Check the pneumatic pilot line and repair if necessary

11.3.7 Makrofon MX-1

Fault description	Cause	Remedy
The makrofon is not activated	The pilot line is interrupted	Identify the line segment and replace if necessary
	The strainer is dirty	Remove and clean or replace the strainer
	The pilot line is blocked	Clean the pilot line
	The pneumatic pilot line is depressurized	Inspect the pilot cylinder, pressure reducer, etc. and repair if necessary

11.4 Correct Supervised Pressure Gauge Display



If the indicator is not in the green zone despite the room temperature being above the minimum permissible temperature, either an extinguishing agent leak has occurred or the supervised pressure gauge is defective. Contact the installing contractor of the system.

Personnel:

- Person in charge of the system

If an extinguishing agent leak is indicated on the SRP, it may be due to an excessively low temperature in the extinguishing agent container installation area.

In this case, the indicator of the supervised pressure gauge is located in the red zone even though no extinguishing agent leak exists.

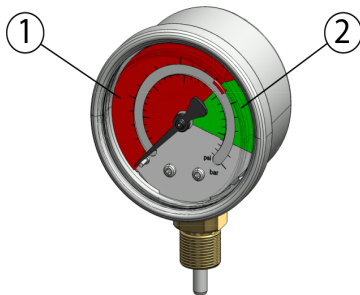

Figure 11.1: Supervised pressure gauge

1. Check whether the temperature in the extinguishing agent container installation area has not fallen below the minimum permissible temperature; See “Technical Data” on page 225.
2. Increase the temperature if necessary.
3. Check the indicator position of the supervised pressure gauge.

The indicator of the supervised pressure gauge must return to the green zone.

11.5 Putting the System Back into Operation



Allow only a servicing contractor or service personnel authorized by the installing contractor to perform the work for the return to service of the system after troubleshooting. If needed, contact can be established through the manufacturer; see page 2.

12 Disassembly and Disposal

After the end of the system's useful life has been reached, the system must be disassembled and disposed of in an environmentally appropriate manner.

Electrical system

DANGER

Life-threatening danger due to electric shock

There is a life-threatening hazard when touching live components.

- **Prior to dismantling, switch off the electrical supply and disconnect it.**

Lack of fire safety

WARNING

Life-threatening danger due to a lack of fire safety

If the system has been taken out of service there is no fire safety. Fires breaking out can result in severe or fatal injuries, as well as significant material damage.

- **Keep functional reserve extinguishing equipment on hand (e.g. fire extinguishers).**

Pressurized extinguishing agent

WARNING

Risk of injury due to pressure in extinguishing agent containers

If extinguishing agent containers are damaged during disassembly and extinguishing agent escapes uncontrollably, there is a risk of severe or even fatal injuries.

- **Only start to dismantle system components if the extinguishing agent containers are removed and safeguarded with a protective valve cap and outlet venting safety plug.**

Escaping extinguishing agent

WARNING

Danger of injury due to escaping extinguishing agent

If the system is unintentionally activated in the course of disassembly, extinguishing agent can escape uncontrollably. This can lead to severe injuries or even death, as well as significant property damage.

- Prior to starting the tasks where a faulty release is possible, ensure that all release devices are removed.
- Immediately exit the extinguishing zone if there is a faulty release.
- Instruct all persons working in the system area with the measures that must be initiated in case of a faulty release.

High pressure and lack of oxygen

WARNING

Risk of injury with emptying of extinguishing agent cylinders

If extinguishing agent cylinders are emptied in an uncontrolled fashion, there is a risk of severe injuries due to extinguishing agent escaping at high pressure, noise, and a lack of oxygen.

- Empty extinguishing agent cylinders in the filling plant.
- Alternatively, empty them into the system piping of the system. For this, create and heed a property-related safety plan.

12.1 Disassembly

Personnel:

- Installing contractor

Protective equipment:

- Industrial hard hat
- Safety goggles
- Safety gloves
- Safety footwear

12.1.1 Taking the system out of service

Prior to starting the disassembly process, the complete system must be taken out of service electrically and mechanically.

1. Take the electric control device or SRP out of service and secure it against restarting.
2. Electrically disconnect the power supply unit and battery.

WARNING

Danger of a faulty release.

3. Remove the electrical release solenoid from the pilot cylinder.
4. Remove the pneumatic pilot line from the pilot cylinders up to the last extinguishing agent container.
5. Disassemble all system components in accordance with locally applicable occupational, health and safety, and environmental protection directives.

12.1.2 Dismantling the extinguishing agent containers

DANGER

Risk of accidents due to heavy pressurized containers

Extinguishing agent containers are very heavy and may be pressurized. If handled improperly, they can pose a life-threatening hazard.

- Always handle extinguishing agent containers with at least 2 people.
- Always use suitable means of transport.
- As soon as possible, secure the valve outlet with an outlet venting safety plug and the valve with a protective valve cap.
- Wear safety gloves, safety footwear, protective goggles and hearing protection.

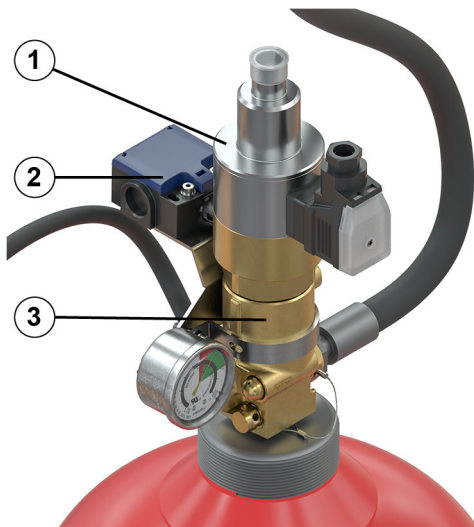

Figure 12.1: Removing the electrical release solenoid

1	Electric release device
2	Electrical release monitoring
3	Valve

1. Remove the monitoring of the electrical release solenoid.
2. Remove the electrical release solenoid from the valve of the primary extinguishing agent container.

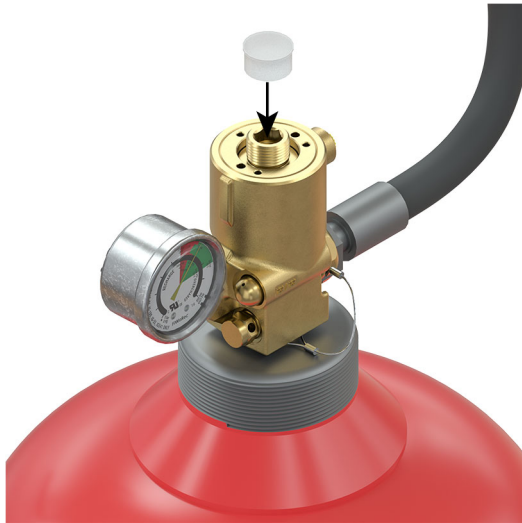

Figure 12.2: Assembling the plastic protective cap

3. Place plastic protective caps onto the valve and onto the electrical release solenoid.



Figure 12.3: Removing the pneumatic pilot lines

1	Pneumatic pilot line
2	Supervised pressure gauge

1. Remove the pneumatic pilot lines from the valves on the extinguishing agent containers.
2. Screw the plugs into all sequence valve and control connections and tighten with a torque of 12 ± 1 Nm (8.85 ± 0.74 ft-lb).
3. Remove the electrical connections for the supervised pressure gauge.
4. Unscrew the supervised pressure gauge with a size 14 flat wrench until loose, then unscrew by hand.



The pressure relief can result in a brief, hazard-free ‘pop’ noise.

5. Secure all supervised pressure gauge connections with plugs at the valves.

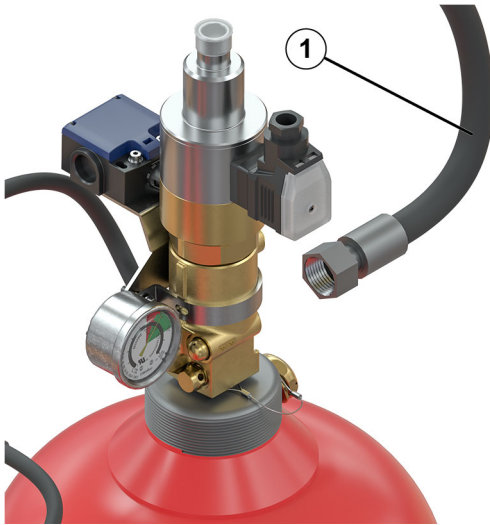

Figure 12.4: Removing the hoses

1	Hose
---	------

6. Unscrew the hoses from the valves.



Store the seals in a safe place.

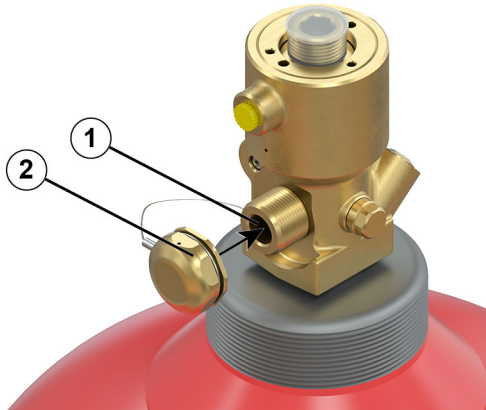

Figure 12.5: Screwing on the safety plug

1	Valve outlet
2	Safety plug

7. Immediately screw safety plug onto all valve outputs with a torque of 26 ft-lb (35 Nm).

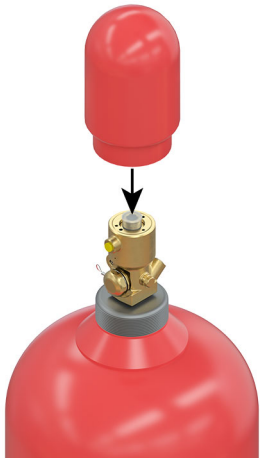

Figure 12.6: Valve protection cap (example)

8. Screw valve protection caps onto the extinguishing agent containers.



Figure 12.7: Removing the mounting brackets

1 Mounting bracket

9. Carefully remove the mounting brackets and place the extinguishing agent containers to the side.

i Return the extinguishing agent containers to a filler for refilling in accordance with transport specifications; See “Transporting extinguishing agent cylinders” on page 52.

10. Fasten the extinguishing agent containers standing up in a suitable transport frame or lying down on a pallet, and secure against sliding.

12.1.3 Disassembling system components

Dismantle all system components in accordance with locally applicable occupational, health and safety, and environmental protection directives.

12.2 Disposal

Personnel:

- Installing contractor

Protective equipment:

- Industrial hard hat
- Hearing protection
- Safety gloves
- Safety footwear

NOTICE

Danger to the environment due to incorrect disposal

Incorrect disposal can cause hazards for the environment.

- **Comply with the applicable legal disposal regulations.**
- **Have electrical scrap and electronic components disposed of by approved specialized companies.**
- **If in doubt, get information concerning environmentally responsible disposal from specialized disposal companies.**

At the end of the equipment's service life, dispose of it in accordance with legal regulations or through the national recycling system.

13 Appendix A - Replacement Components

13.1 Replacement component part numbers

See individual product sheets for component-level approvals.

*Items are custom order and must be sourced. Please contact a Viking sales representative for lead times.

**Items with custom orifices, refer to the appropriate technical data sheet for full ordering number.

Description	Part Number
Tank assembly, Oxexo, 140 L, 4,351 PSI (300 bar) at 59°F (15°C), Argon	4001034
Tank assembly, Oxexo, 140 L, 4,351 PSI (300 bar) at 59°F (15°C), Argon, Canada	4001034C
Tank assembly, Oxexo, 140 L, 4,351 PSI (300 bar) at 59°F (15°C), Nitrogen	4001054
Tank assembly, Oxexo, 140 L, 4,351 PSI (300 bar) at 59°F (15°C), Nitrogen, Canada	4001054C
Tank assembly, Oxexo, 80 L, 2,901 PSI (200 bar) at 59°F (15°C), Argon	4001024
Tank assembly, Oxexo, 80 L, 2,901 PSI (200 bar) at 59°F (15°C), Nitrogen	4001044
Tank assembly, Oxexo, 80 L, 4,351 PSI (300 bar) at 59°F (15°C), Argon	4001030
Tank assembly, Oxexo, 80 L, 4,351 PSI (300 bar) at 59°F (15°C), Nitrogen	4001050
Tank assembly, Oxexo, 80 L, 2,901 PSI (200 bar) at 59°F (15°C), Argon, Canada	4001024C
Tank assembly, Oxexo, 80 L, 2,901 PSI (200 bar) at 59°F (15°C), Nitrogen, Canada	4001044C
Tank assembly, Oxexo, 80 L, 4,351 PSI (300 bar) at 59°F (15°C), Argon, Canada	4001030C
Tank assembly, Oxexo, 80 L, 4,351 PSI (300 bar) at 59°F (15°C), Nitrogen, Canada	4001050C
Tank assembly, Oxexo, 30 L, 2,901 PSI (200 bar) at 59°F (15°C), Argon	4006190
Tank assembly, Oxexo, 30 L, 2,901 PSI (200 bar) at 59°F (15°C), Nitrogen	4006191
Tank assembly, Oxexo, 30 L, 4,351 PSI (300 bar) at 59°F (15°C), Argon	4006192
Tank assembly, Oxexo, 30 L, 4,351 PSI (300 bar) at 59°F (15°C), Nitrogen	4006193
Tank assembly, Oxexo, 30 L, 2,901 PSI (200 bar) at 59°F (15°C), Argon, Canada	4006190C
Tank assembly, Oxexo, 30 L, 2,901 PSI (200 bar) at 59°F (15°C), Nitrogen, Canada	4006191C
Tank assembly, Oxexo, 30 L, 4,351 PSI (300 bar) at 59°F (15°C), Argon, Canada	4006192C
Tank assembly, Oxexo, 30 L, 4,351 PSI (300 bar) at 59°F (15°C), Nitrogen, Canada	4006193C
Manual release device QRV	914028
Electrical release device QRV	914027D
Solenoid reset tool	934652
Monitor switch, Oxexo, Actuator, NPT	930865D
Warning sign, outside, nitrogen, English	24587a

Description	Part Number
Warning sign, inside, nitrogen, English	24588
Warning sign, outside, argon, English	24589
Warning sign, inside, argon, English	24590
Warning sign, cylinder storage area, English	26407
Warning sign, outside, nitrogen, French	24587-F
Warning sign, inside, nitrogen, French	24588-F
Warning sign, outside, argon, French	24589-F
Warning sign, inside, argon, French	24590-F
Warning sign, cylinder storage area, French	26407-F
Warning sign, outside, nitrogen, Spanish	24587-S
Warning sign, inside, nitrogen, Spanish	24588-S
Warning sign, outside, argon, Spanish	24589-S
Warning sign, inside, argon, Spanish	24590-S
Warning sign, cylinder storage area, Spanish	26407-S
Check valve (CF systems)	886030
Discharge hose with gaskets, 375 mm length, PR inert gas system	934921D
Discharge hose with gaskets, 600 mm length, PR inert gas system	934922D*
Discharge hose with gaskets and CF regulator, 375 mm length, CF system	25763
Discharge hose with gaskets and CF regulator, 600 mm length, CF system	25764*
Bend Radius Tool 5.12" (discharge hose)	26412
Constant flow regulator (included with 25763 and 25764)	4003160
Gasket, inert gas, discharge hose to manifold, hose to CF regulator	149890
Gasket, inert gas, tank to discharge hose	149970
Pressure gauge, 2901 psi, NO under pressure	927612
Pressure gauge, 2901 psi, NC under pressure	927615
Pressure gauge, 4351 psi, NO under pressure	927616
Pressure gauge, 4351 psi, NC under pressure	927617
Pneumatic time delay	926815
Lockout valve assembly, pilot line	878070D
Pressure regulator, Oxco, 9201/145 psi, pilot	926811
Shuttle non-return valve, pilot (M/R)	886247D
Pilot line pressure relief, Oxco	24498
Pilot line pressure relief with manual release, Oxco	24499
Pilot hose, high pressure, USA specific, 20" length	24467
Pilot hose, high pressure, USA specific, 39" length	24468
Pilot hose, high pressure, USA specific, 59" length	24469

Description	Part Number
Pilot hose, high pressure, USA specific, 20" length, kit	25132
Pilot hose, high pressure, USA specific, 39" length, kit	25133
Pilot hose, high pressure, USA specific, 59" length, kit	25134
Pilot hose adapter	125566
Pilot hose tee	912487
Pilot hose coupler	125920
Bend Radius Tool 2" (pilot lines)	26408
Occupiable space kit	25128
Selector valve assembly, Oxexo PR 2" NPT, 5294 psi	24815
Selector valve assembly, Oxexo CF 1" NPT, 2031 psi	934713D
Selector valve assembly, Oxexo CF 1.5" NPT, 2031 psi	934714D
Selector valve assembly, Oxexo CF 2" NPT, 2031 psi	934715D
Selector valve assembly, Oxexo CF 2.5" NPT, 2031 psi	934826D*
Selector valve assembly, Oxexo CF 3" NPT, 2031 psi	934827D*
Selector valve assembly, Oxexo CF 4" NPT, 2031 psi	934828D*
Lockout valve assembly, Oxexo PR, 5294 psi	24768
Lockout valve assembly, Oxexo CF 1" NPT, 2031 psi	4005115D
Lockout valve assembly, Oxexo CF 1.5" NPT, 2031 psi	4005116D
Lockout valve assembly, Oxexo CF 2" NPT, 2031 psi	4005117D
Lockout valve assembly, Oxexo CF 2.5" NPT, 2031 psi	4005082D*
Lockout valve assembly, Oxexo CF 3" NPT, 2031 psi	4005083D*
Lockout valve assembly, Oxexo CF 4" NPT, 2031 psi	4005084D*
Limit switch, push pin	930351
Limit switch, roll push pin	930352
Pressure relief, Oxexo PR, 4351 PSI, manifold, NPT	886281D
Pressure relief, Oxexo PR, 2901 PSI, manifold, NPT	885136D
Pressure relief, Oxexo CF, 957 PSI, manifold, NPT	888007D
Sealing ring, Oxexo manifold relief	920804
Pressure reducer 3/4" NPT / BSPT with protective screen (single tank systems only)	25011**
Pressure reducer 3/4" NPT / BSPT (single tanks systems only)	25012**
Pressure reducer 2" NPT / 2" NPT with protective screen	25013**
Pressure reducer 2" NPT / 2" NPT	25014**
Pressure reducer 2" NPT / 2-1/2" NPT with protective screen	25015**
Pressure reducer 2" NPT / 2-1/2" NPT	25016**
Pressure reducer 2" NPT / 3" NPT with protective screen	25017**
Pressure reducer 2" NPT / 3" NPT	25018**

Description	Part Number
Adapter, male 3/4" BSPP x male 3/4" BSPT (single tank PR systems only)	887706
Pneumatic limit switch assembly	826758D
Pneumatic horn (Makrofon), NPT kit, inert gas	860050D
Manifold, 2" 2 out, PR System, 30L/80L	25528
Manifold, 2" 3 out, PR System 30L/80L	25054
Manifold, 2" 2 out, PR System, 140L	26722
Manifold, 2" 3 out, PR System, 140L	26729
Manifold 2" 2 out, CF System 30L/80L	25759
Manifold 2" 3 out, CF System 30L/80L	25760
Manifold, 2" 2 out, CF System, 140L	26705
Manifold, 2" 3 out, CF System, 140L	26713
Pilot cylinder, 80 L	4003404
Pilot cylinder, 30 L	4006215
1/2" NPT VN Nozzle, 180° style	934164**
1/2" NPT VN Nozzle, 360° style	918745**
3/4" NPT VN Nozzle, 180° style	934165**
3/4" NPT VN Nozzle, 360° style	918746**
1" NPT VN Nozzle, 180° style	934166**
1" NPT VN Nozzle, 360° style	918747**
1-1/4" NPT VN Nozzle, 180° style	934167**
1-1/4" NPT VN Nozzle, 360° style	918748**
1-1/2" NPT VN Nozzle, 180° style	934168**
1-1/2" NPT VN Nozzle, 360° style	918749**
VN Nozzle Socket wrench, 1/2" Drive, 22 mm	25099
VN Nozzle Socket wrench, 1/2" Drive, 27 mm	25100
VN Nozzle Socket wrench, 1/2" Drive, 32 mm	25101
VN Nozzle Socket wrench, 3/4" Drive, 41 mm	25232
VN Nozzle Socket wrench, 3/4" Drive, 46 mm	25233
DCM Nozzle dust protection seal, 1/2"	24454
DCM Nozzle dust protection seal, 3/4"	24455
DCM Nozzle flange, 1/2"	24459
DCM Nozzle flange, 3/4"	24460
1/2" NPT DCM Nozzle	23379**
3/4" NPT DCM Nozzle	24245**
Quick release valve - 200 bar	914041
Quick release valve - 300 bar	930367

Description	Part Number
Refill adapter valve to CGA G 80	23957
Pneumatic test kit	25761
Cylinder brackets, 30L & 80L	24196W/B
Cylinder brackets, 140L	26449W/B

14 Appendix B - Racking Assembly

This chapter is intended for expert installation personnel who are familiar with the handling of the fire extinguishing systems described herein.

14.1 Introduction

The Oxeo support and racking system is ordered and delivered separately from the system. The specific arrangement and measurements of the racking system components depends upon the size and number of cylinders included in the design of the system.

There are slight differences in the assembly measurements between the single, double, and triple row arrangements and the tolerance stack-ups can cause problems if the instructions are not followed carefully.

14.2 Racking Configurations and Ordering Information

There are three types of mounting configurations for the support system:

1. Wall mount
2. 1-sided floor mount
3. Back-to-back floor mount

Each type can be customized however, the systems are limited to 3 rows with a maximum of 18 cylinders per row. To order a pre-configured racking system, use the information in Tables A1, A2, and A3 below then order the appropriate web assembly from Table B. For additional or replacement parts, refer to "" on page 232.

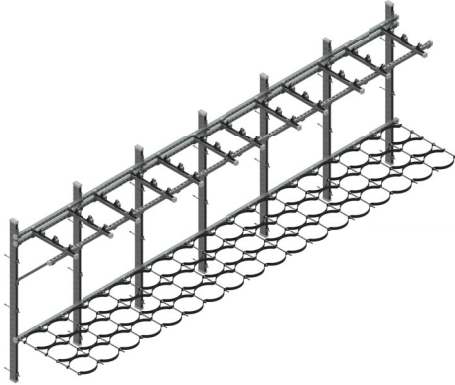

Figure 14.1: Wall Mounted Configuration

Table A1 - Wall mounted

All configurations are for 80L tanks unless otherwise noted.

Part number	Cylinder rows	Width (cylinders)
24266	1	18
24267	1	15
24268	1	12
24269	1	9
24270	1	6
24271	1	3
24252	2	18
24253	2	15
24254	2	12
24255	2	9
24256	2	6
24257	2	3
24259	3	18
24260	3	15
24261	3	12
24262	3	9
24263	3	6
24264	3	3
25880*	1	3
* For 30L cylinders only.		

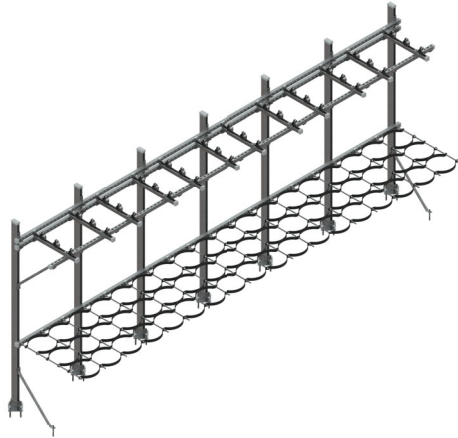

Table A2 - Floor mounted, single sided

All configurations are for 80L tanks unless otherwise noted.

Part number	Cylinder rows	Width (cylinders)
24217	1	18
24218	1	15
24219	1	12
24220	1	9
24221	1	6
24222	1	3
24210	2	18
24211	2	15
24212	2	12
24213	2	9
24214	2	6
24215	2	3
24224	3	18
24225	3	15
24226	3	12
24227	3	9
24228	3	6
24229	3	3
25882*	1	3
* For 30L cylinders only.		

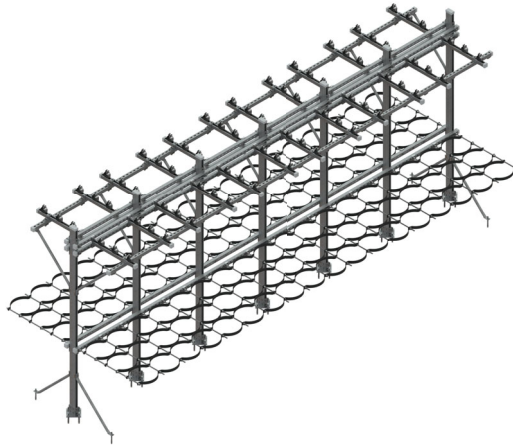

Table A3 - Floor mounted, double sided (back to back)

All configurations are for 80L tanks unless otherwise noted.

Part number	Cylinder rows (on each side)	Width (cylinders)
24291	1	18
24292	1	15
24293	1	12
24294	1	9
24295	1	6
24296	1	3
24273	2	18
24274	2	15
24275	2	12
24276	2	9
24277	2	6
24278	2	3
24284	3	18
24285	3	15
24286	3	12
24287	3	9
24288	3	6
24289	3	3

14.3 Spare Parts And Component Technical Data

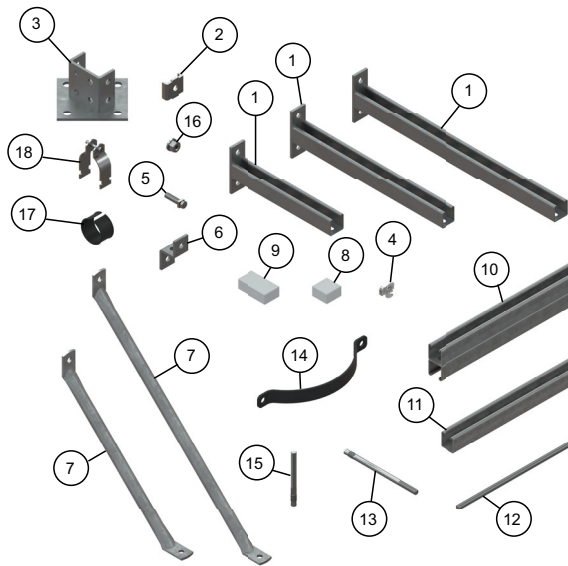

Figure 14.2: Unistrut spare components

Unless otherwise stated, all components listed below are for the 30L/80L cylinders.

Table B

Ref#	Part Number (replacement)	Description	Size	Material
1	24125	Unistrut cantilever bracket	1 5/8" x 1 5/8" x 12"	Steel
	24126	Unistrut cantilever bracket	1 5/8" x 1 5/8" x 18"	
	24127	Unistrut cantilever bracket	1 5/8" x 1 5/8" x 24"	
2	24128	Wolf washer	1 5/8"	Steel

Ref#	Part Number (replacement)	Description	Size	Material
3	24131	Base support	1 5/8" x 3 1/4"	Steel
4	24132	Retaining nut	1 5/8"	Nickel Steel
5	24133	Break-off bolt	1/2" x 13	Steel
6	24140	Z bracket	1 5/8"	Electro- galvanized steel
7	24142	Brace	1 5/8" x 18"	
	24141	Brace	1 5/8" x 24"	
8	24158	End cap	1 5/8" x 1 5/8"	Vinyl
9	24157	End cap (double)	1 5/8" x 3 1/4"	

Ref#	Part Number (replacement)	Description	Size	Material
10	24648-09050	Unistrut channel double	1 5/8" x 3 1/4" x 90 1/2", 12 gauge	Stainless steel
	24648-07850		1 5/8" x 3 1/4" x 78 1/2"	
	24648-05300		1 5/8" x 3 1/4" x 53"	
	24648-06500		1 5/8" x 3 1/4" x 65"	
	24648-12000		1 5/8" x 3 1/4" x 120"	
11	24649-01200	Unistrut channel	1 5/8" x 1 5/8" x 12"	
	24649-03975	Unistrut channel	1 5/8" x 1 5/8" x 39 3/4"	
	24649-07475	Unistrut channel	1 5/8" x 1 5/8" x 74 3/4"	
	24649-11000	Unistrut channel	1 5/8" x 1 5/8" x 110"	
	24649-14550	Unistrut channel	1 5/8" x 1 5/8" x 145 1/2"	
	24649-18100	Unistrut channel	1 5/8" x 1 5/8" x 181"	
	24649-21650	Unistrut channel	1 5/8" x 1 5/8" x 216 1/2"	
	24649-24000	Unistrut channel	1 5/8" x 1 5/8" x 240"	
12	24650-00400	Threaded rod	1/2"-13 X 4"	Steel
	24650-01250	Threaded rod	1/2"-13 X 12 1/2"	
	24650-02450	Threaded rod	1/2"-13 X 24 1/2"	
	24650-03650	Threaded rod	1/2"-13 X 36 1/2"	
	24650-12000	Threaded rod	1/2"-13 X 120"	
13	24139	Concrete anchor (inc. nut and washer)	5/8" x 5"	Zinc plated carbon steel
	24191	Concrete anchor (inc. nut and washer)	1/2" x 5 1/2"	
	24250	Concrete anchor (inc. nut and washer)	1/2" x 8 1/2"	
14	24196W/B	30L/80L cylinder bracket	n/a	Steel
	26449W/B	140L cylinder bracket	n/a	

Ref#	Part Number (replacement)	Description	Size	Material
15	24208	Cylinder brace assembly	1 row x 2 cylinder closed	Materials vary by component. Refer to individual items above.
	24207	Cylinder brace assembly	1 row x 3 cylinder open	
	24206	Cylinder brace assembly	1 row x 3 cylinder closed	
	24205	Cylinder brace assembly	2 row x 1 cylinder closed	
	24204	Cylinder brace assembly	2 row x 2 cylinder closed	
	24203	Cylinder brace assembly	2 row x 3 cylinder open	
	24202	Cylinder brace assembly	2 row x 3 cylinder closed	
	24201	Cylinder brace assembly	3 row x 1 cylinder closed	
	24200	Cylinder brace assembly	3 row x 2 cylinder closed	
	24199	Cylinder brace assembly	3 row x 3 cylinder open	
	24198	Cylinder brace assembly	3 row x 3 cylinder closed	
16	23376	Serrated flange nut	--	Stainless steel
17	24184-00750	Pipe clamp cushion	7.5"	Rubber
18	24183	Pipe clamp	2 3/8"	Electro- galvanized steel

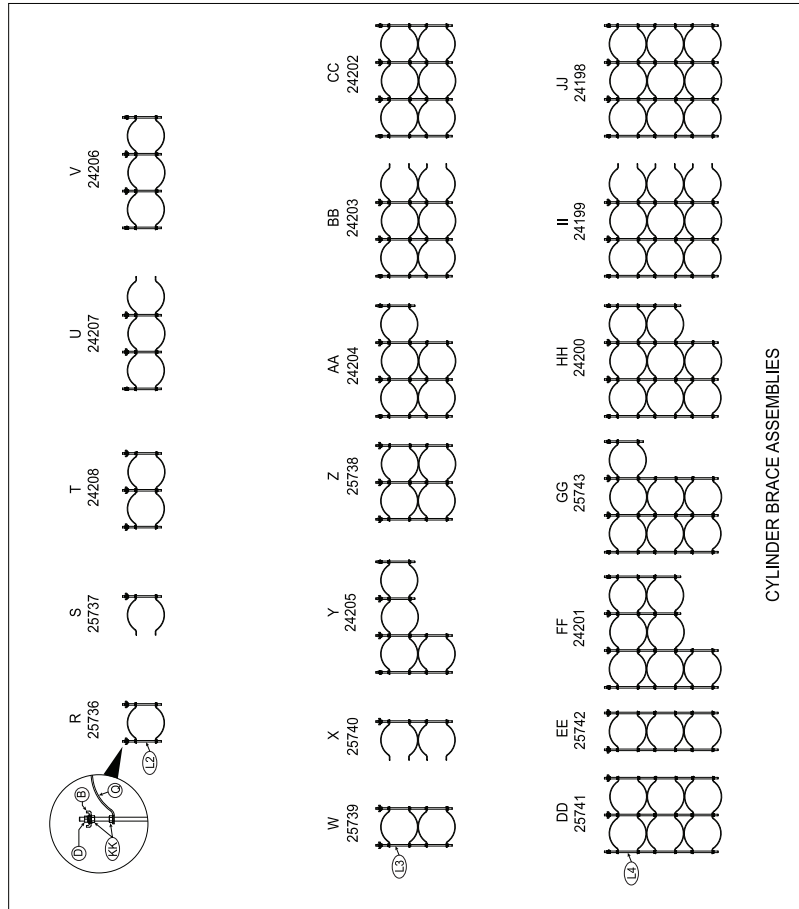

Figure 14.3: Cylinder web assemblies (30L/80L only)

Table C

Ref#	Part Number (replacement)	Description	Size	Materials of Construction/Material Standards	Image **NOT TO SCALE**
R	25736	Cylinder brace assembly	1 row x 1 cylinder closed	Materials vary by component. Refer to individual items above.	See page 6.
S	25737	Cylinder brace assembly	1 row x 1 cylinder open		
T	24208	Cylinder brace assembly	1 row x 2 cylinder closed		
U	24207	Cylinder brace assembly	1 row x 3 cylinder open		
V	24206	Cylinder brace assembly	1 row x 3 cylinder closed		
W	25739	Cylinder brace assembly	2 row x 1 cylinder closed		
X	25740	Cylinder brace assembly	2 row x 1 cylinder open		
Y	24205	Cylinder brace assembly	2 row x 1 cylinder closed		
Z	25738	Cylinder brace assembly	2 row x 2 cylinder closed		
AA	24204	Cylinder brace assembly	2 row x 2 cylinder closed		
BB	24203	Cylinder brace assembly	2 row x 3 cylinder open		
CC	24202	Cylinder brace assembly	2 row x 3 cylinder closed		
DD	25741	Cylinder brace assembly	3 row x 2 cylinder closed		
EE	25742	Cylinder brace assembly	3 row x 1 cylinder closed		
FF	24201	Cylinder brace assembly	3 row x 1 cylinder closed		
GG	25743	Cylinder brace assembly	3 row x (2 cylinder x 2 plus 1 cylinder)		
HH	24200	Cylinder brace assembly	3 row x 2 cylinder closed		

Ref#	Part Number (replacement)	Description	Size	Materials of Construction/Material Standards	Image **NOT TO SCALE**
II	24199	Cylinder brace assembly	3 row x 3 cylinder open		
JJ	24198	Cylinder brace assembly	3 row x 3 cylinder closed		
KK	23376	Serrated flange nut			

14.4 Assembling the Rack

14.4.1 Safety



CAUTION

Cutting hazard

Some components have sharp edges that can cause cuts.

- Wear safety gloves during this procedure.



CAUTION

Personal injury hazard

Some components are heavy and can cause personal injury if not handled properly.

At least two (2) people are required for this installation.

14.4.2 Tools Required

- Drill
- 5/8" and 1/2" Concrete drill bits
- Standard and/or adjustable wrenches
- Measuring tape
- Level
- Hammer

14.4.3 Installation Tips

Retaining nut: To install the retaining nut, it's recommended to place the retaining nut inside the Unistrut channel and use 2 fingers to twist it into the proper orientation. The retaining nuts include a plastic guide that may dislodge from the nut during installation and can easily be re-attached. These retaining nuts are not required.

Break-off bolts: The break-off bolts include a hexagonal head on top of the square head that is designed to break off a specific torque value. Once head is broken off, the bolt is properly tightened.

Cylinder web/clamps: The cylinder web assemblies need to be installed properly in order to have correct spacing of the racking going down the line. If the bracing webs are not installed properly, the tolerance stack-up will affect the installation further down the line and will need to be corrected.

14.4.4 Assembly Procedure Information

Refer to "Table A2 - Floor mounted, single sided" on page 230 for reference descriptions.



Unless explicitly instructed, it is recommended to install all components loosely at first, adjust as necessary to achieve the desired end result, and tighten down/secure everything at the end.



Build the support racking system starting at 1 end and loosely install the opposite end and cross support to assist in configuring the remainder of the components in-between.

14.4.5 Pre-assembling The Upright Frame Members

- Loosely install retaining nuts (D), Z-brackets (F), and base supports (C) using the break-off bolts (E), as shown. Do not tighten the break-off bolts yet.
Wall mount versions do not require base supports.
- Install end cap (double) (I) on top of Unistrut double channel (J) used as upright frame member.

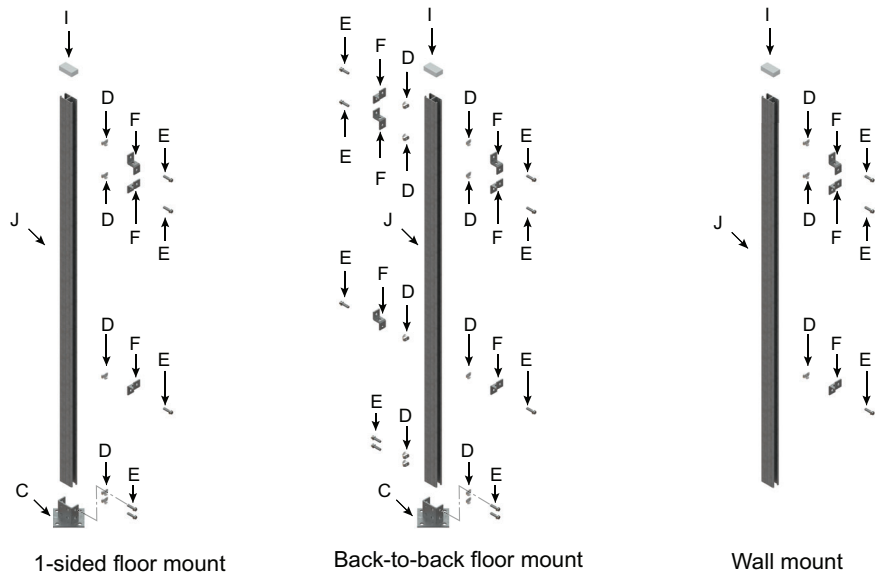

Figure 14.4: Assembling the upright supports

14.4.6 Installing the Support Structure

- Measure and mark the location of the first upright post.
- Drill pilot holes for the concrete anchors (wall or floor depending on your system).
- Install the upright post using the concrete anchors (P-wall or M-floor), wolf washers (B), and the included nuts and washers.

Floor mount versions use the 1/2" X 5 1/2" concrete anchor.

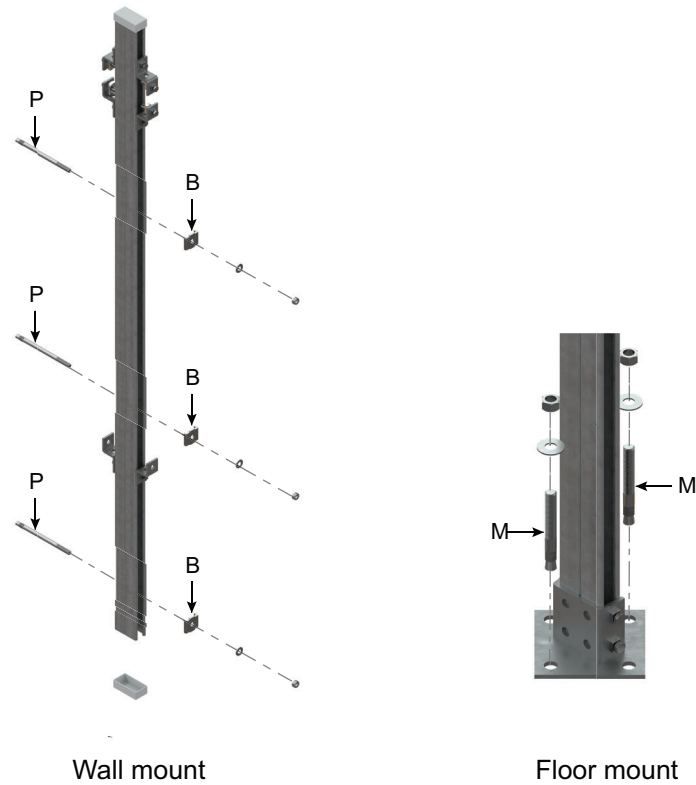

Figure 14.5: Mounting the upright supports

4. Position the bottom Z-bracket approximately 30 inches from the floor and snug the break-off bolt in place but do not break it off.

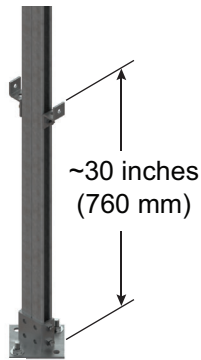

Figure 14.6: Locating the horizontal support brackets

5. For floor mount versions, loosely install floor brace (G) using the retaining nut (D), wolf washer (B), and break-off bolt (E) attached to the post, and concrete anchor (N) in the floor.

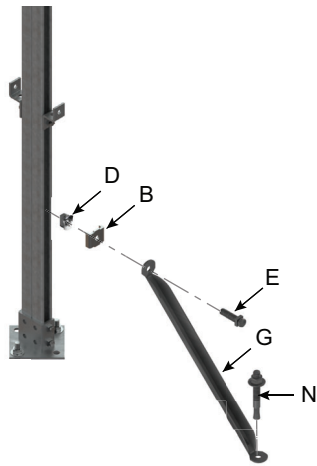

Figure 14.7: Mounting the floor braces

6. Measure and mark the location for the next post and loosely install it in the appropriate location.

Do not anchor this post in place yet.

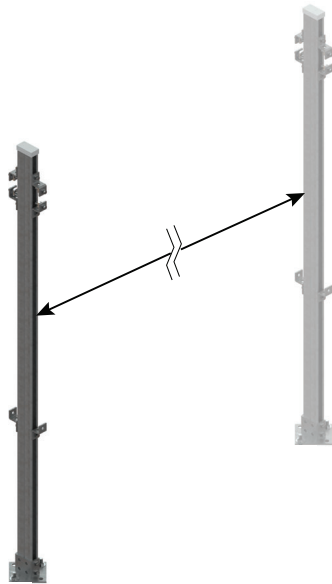

Figure 14.8: Installing the opposite end support

7. Install the horizontal cross piece (K) into the Z-brackets as shown.
8. Verify the horizontal cross piece (K) and vertical posts are level.

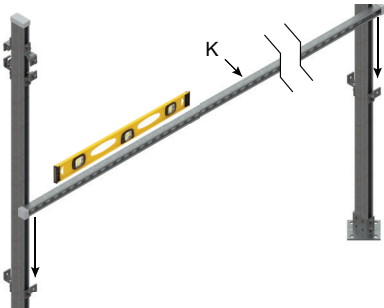

Figure 14.9: Leveling the horizontal support

14.4.7 Pre-assembling the Upper Horizontal Support Structure

For larger configurations, it may be easier to pre-assemble the cantilever bracket assemblies and mount them after the horizontal supports are installed. For smaller systems, it is recommended to assemble as described below.

Cantilever Brackets

1. Cut the rubber to length (if necessary) and place it inside the clamp (DD) if desired or set aside for later installation; install the bolt and nut.
2. Slide the clamp assembly onto the cantilever brackets (A).
3. Mount the cantilever brackets to the horizontal supports (top and bottom) using the wolf washers (B), inserts (D), and break-off bolts (E).
4. Lift and install the horizontal support assembly to the upright posts.

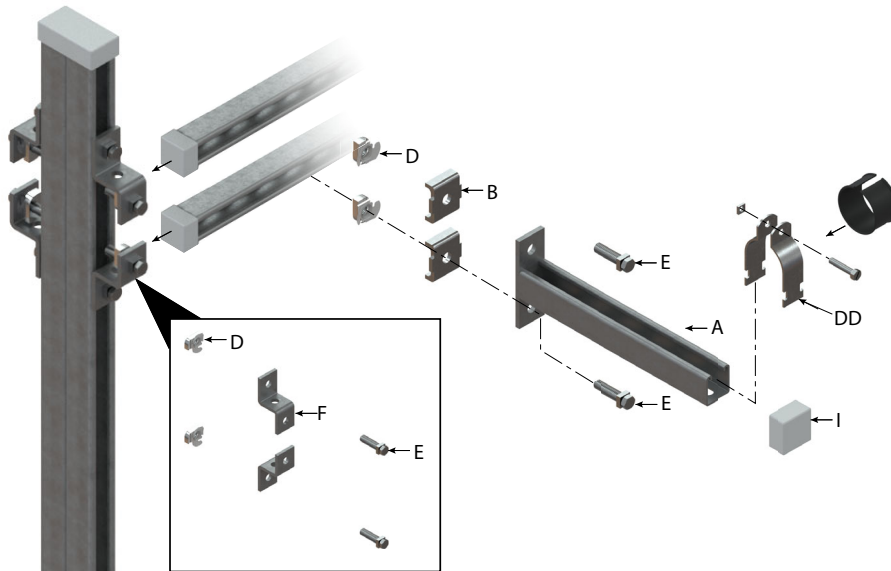

Figure 14.10: Assembling the upper support structure

14.4.8 Installing the Cylinder Bracket Assemblies

1. Place the next upright post into its approximate position (for floor mount versions, install the base support onto the post).
2. Place retaining nut (D) into the channel and push into position BEHIND the Z-bracket (F).

Use the farthest hole on the horizontal cross piece for the first threaded rod to ensure proper alignment.

3. Install two nuts onto the threaded rod (L) facing opposite each other as shown.
4. Install the threaded rod into the retaining nut (D).
5. Tighten the rod until the end is flush with the back of the retaining nut. Use a finger to feel the back side of the nut as you tighten.
6. In-between uprights, an additional wolf washer (B) is required as shown.
7. Install all threaded rod assemblies for the entire racking system before continuing.

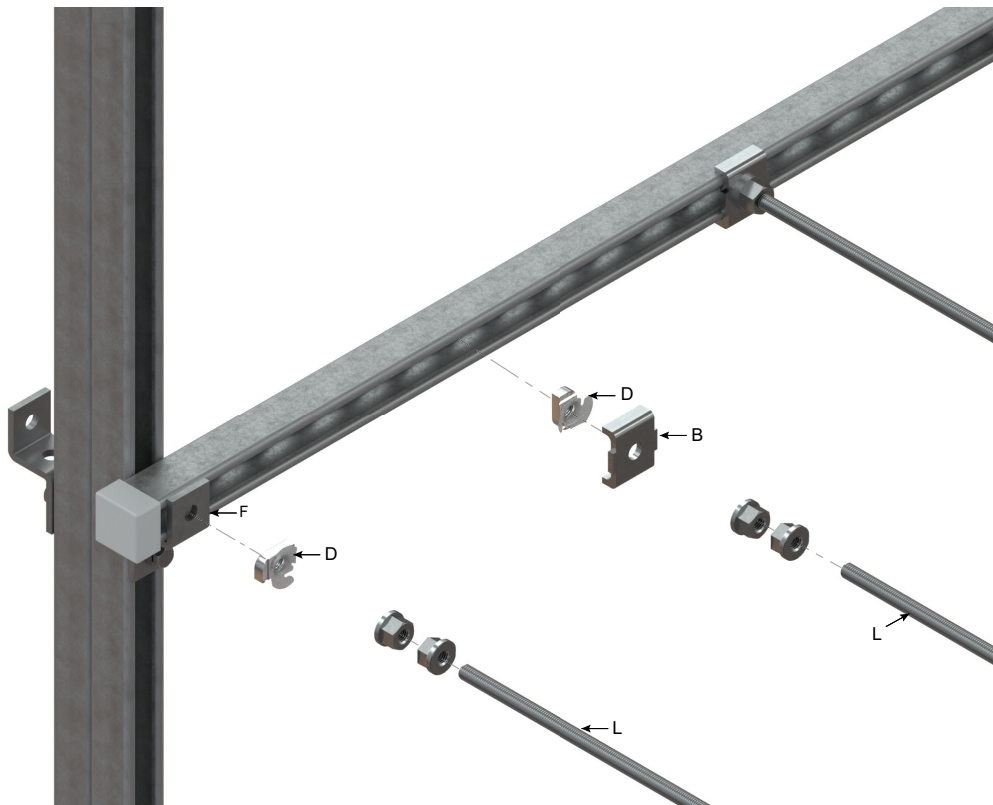

Figure 14.11: Installing the cylinder bracket rods

8. Install a cylinder bracket (Q) onto the first set of threaded rods (L).
9. Adjust the position of the nuts to ensure the bracket is aligned correctly.
10. Skip one span and install another bracket. Continue installing brackets down the line skipping one span each time.

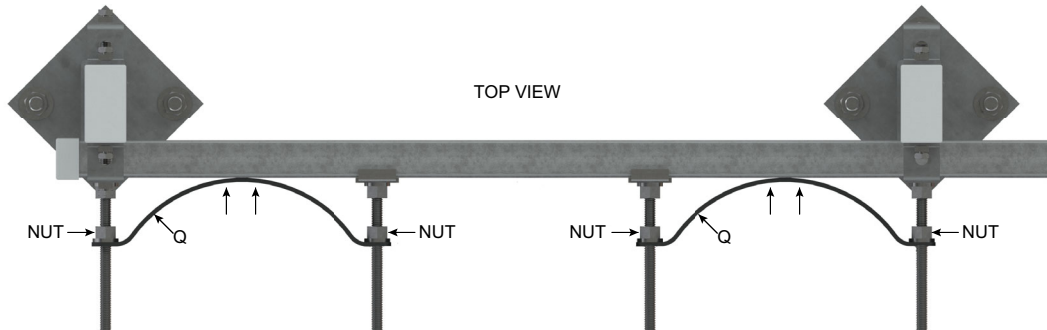

Figure 14.12: Cylinder bracket installation, every other span skipped

11. Install the remaining bracket (Q) in the open span(s).

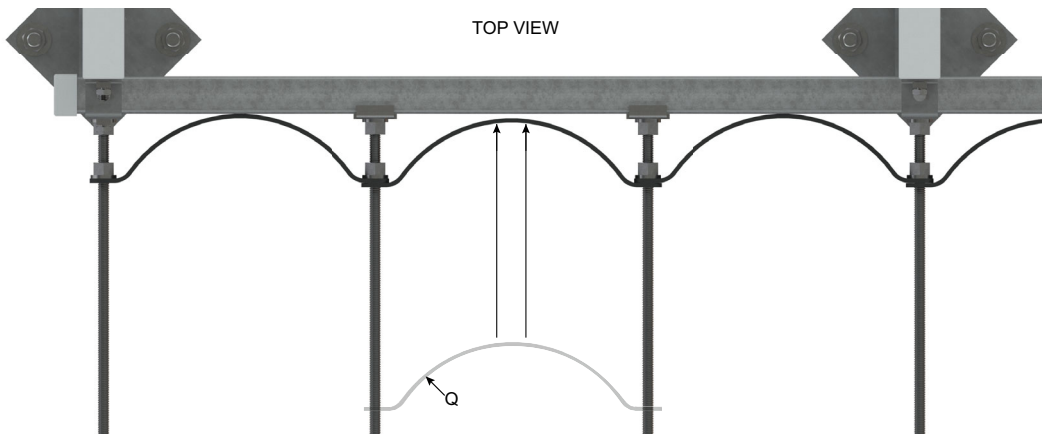

Figure 14.13: Cylinder bracket installation, no spans skipped

For larger systems with multiple rows of tanks, consider placing the cylinders into the racking assembly at this point to ensure web assemblies will be oriented correctly.

12. Install remaining brackets in the manner described above and alternating orientations to support the cylinders as shown below.

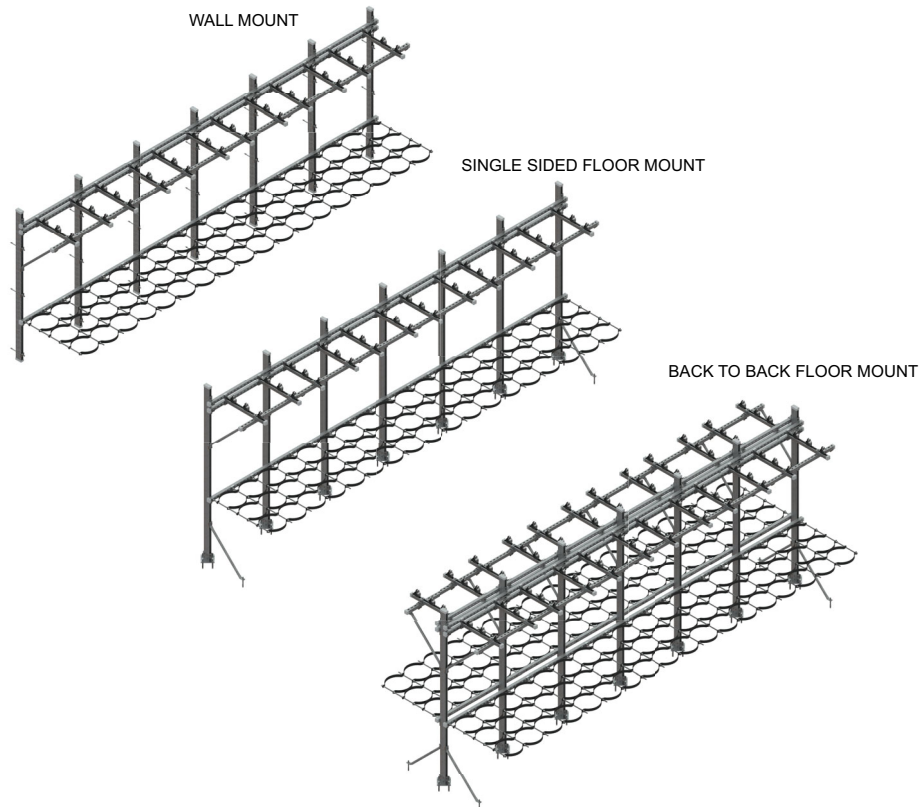

Figure 14.14: Fully assembled racking unit

Refer to Chapter 6 for instructions regarding manifolds and cylinder connections.

15 Safety Data Sheet - IG-01 (Argon)

15.1 SDS - ARGON



Argon IG-01

Safety Data Sheet

according to Federal Register / Vol. 77, No. 58 / Monday, March 26, 2012 / Rules and Regulations

Issue date: 05/16/2022

Version: 1.0

SECTION 1: Identification

1.1. Identification

Product form : Substance
 Substance name : Argon IG-01

1.2. Recommended use and restrictions on use

Use of the substance/mixture : Fire extinguishing agent

1.3. Supplier

Viking Corporation
 210 N. Industrial Park Drive
 Hastings, MI 49058 - USA
 T 269-945-9501

1.4. Emergency telephone number

Emergency number : ChemTel (Contract number MIS0006772) - USA and Canada: 1(800) 225-3924, International: +1(813) 248-0585

SECTION 2: Hazard(s) Identification

2.1. Classification of the substance or mixture

GHS-US classification

Press. Gas (Comp.) H280
 Simple Asphy SIAS

2.2. GHS Label elements, including precautionary statements

GHS US labelling

Hazard pictograms (GHS US) :



Signal word (GHS US) : Warning

Hazard statements (GHS US) : H280 - Contains gas under pressure; may explode if heated.
 May displace oxygen and cause rapid suffocation

Precautionary statements (GHS US) : P410+P403 - Protect from sunlight. Store in a well-ventilated place.

2.3. Other hazards which do not result in classification

No additional information available

2.4. Unknown acute toxicity (GHS US)

Not applicable

SECTION 3: Composition/information on ingredients

3.1. Substances

Name	Product identifier	%
Argon	(CAS-No.) 7440-37-1	100

3.2. Mixtures

Not applicable

SECTION 4: First-aid measures

4.1. Description of first aid measures

First-aid measures general : If exposed or concerned, get medical attention/advice. Show this safety data sheet to the doctor in attendance. Wash contaminated clothing before re-use. Never give anything to an unconscious person.

First-aid measures after inhalation : IF INHALED: Remove to fresh air and keep at rest in a position comfortable for breathing. Get medical attention if breathing is affected. If breathing is difficult, supply oxygen.

05/17/2022

Argon IG-01

Argon IG-01

Safety Data Sheet

according to Federal Register / Vol. 77, No. 58 / Monday, March 26, 2012 / Rules and Regulations

First-aid measures after skin contact	: IF ON SKIN (or clothing): Remove affected clothing and wash all exposed skin with water for at least 15 minutes. If irritation develops or persists, get medical attention. Thaw frosted parts with lukewarm water. Do not rub affected area. Get immediate medical advice/attention.
First-aid measures after eye contact	: IF IN EYES: Immediately flush with plenty of water for at least 15 minutes. Remove contact lenses if present and easy to do so. Continue rinsing if pain, blinking, or irritation develops or persists, get medical attention. Continue rinsing. Thaw frosted parts with lukewarm water. Do not rub affected area. Get immediate medical advice/attention.
First-aid measures after ingestion	: IF SWALLOWED: rinse mouth thoroughly. Do not induce vomiting without advice from poison control center. Get medical attention if you feel unwell.

4.2. Most important symptoms and effects (acute and delayed)

Symptoms/effects	: May displace oxygen and cause rapid suffocation. Unconsciousness.
Symptoms/effects after inhalation	: May displace oxygen and cause rapid suffocation. Unconsciousness.
Symptoms/effects after skin contact	: May cause skin irritation. Contact with the product may cause cold burns or frostbite.
Symptoms/effects after eye contact	: Direct contact with eyes is likely to be irritating. Contact with the liquid may cause frostbite and serious damage to eyes.
Symptoms/effects after ingestion	: May cause gastrointestinal irritation.

4.3. Immediate medical attention and special treatment, if necessary

No additional information available

SECTION 5: Fire-fighting measures

5.1. Suitable (and unsuitable) extinguishing media

Suitable extinguishing media : Use extinguishing media appropriate for surrounding fire.

5.2. Specific hazards arising from the chemical

Fire hazard	: Non-flammable gas.
Explosion hazard	: Contains gas under pressure; may explode if heated.
Reactivity	: No dangerous reactions known under normal conditions of use. In a fire or if heated, a pressure increase will occur and the container may burst.

5.3. Special protective equipment and precautions for fire-fighters

Firefighting instructions	: Exercise caution when fighting any chemical fire. Do not dispose of fire-fighting water in the environment. Prevent human exposure to fire, fumes, smoke and products of combustion.
Protection during firefighting	: Do not enter fire area without proper protective equipment, including respiratory protection.

SECTION 6: Accidental release measures

6.1. Personal precautions, protective equipment and emergency procedures

General measures : Evacuate area. Keep upwind. Ventilate area. Spill should be handled by trained cleaning personnel properly equipped with respiratory and eye protection.

6.1.1. For non-emergency personnel

Protective equipment	: Wear Protective equipment as described in Section 8.
Emergency procedures	: Evacuate unnecessary personnel.

6.1.2. For emergency responders

Protective equipment : Wear suitable protective clothing, gloves and eye or face protection. For further information refer to section 8: "Exposure controls/personal protection".

6.2. Environmental precautions

Prevent entry to sewers and public waters. Notify authorities if liquid enters sewers or public waters. Avoid release to the environment.

6.3. Methods and material for containment and cleaning up

For containment	: Stop leak if safe to do so.
Methods for cleaning up	: Exclude sources of ignition and ventilate the area. Ground equipment electrically. Use explosion-proof equipment.

6.4. Reference to other sections

See Sections 8 and 13.

05/17/2022

Argon IG-01

Argon IG-01

Safety Data Sheet

according to Federal Register / Vol. 77, No. 58 / Monday, March 26, 2012 / Rules and Regulations

SECTION 7: Handling and storage

- 7.1. Precautions for safe handling**
 Precautions for safe handling : Do not handle until all safety precautions have been read and understood. Provide good ventilation in process area to prevent formation of vapour. Do not breathe gas. Wash hands and other exposed areas with mild soap and water before eating, drinking or smoking and when leaving work.
- 7.2. Conditions for safe storage, including any incompatibilities**
 Storage conditions : Keep container tightly closed. Store in a well-ventilated place. Keep cool. Store in a dry place.

SECTION 8: Exposure controls/personal protection

8.1. Control parameters

Argon (7440-37-1)		
ACGIH	Remark (ACGIH)	TLV® Basis: Simple Asphyxiant
ACGIH	Regulatory reference	ACGIH 2022
OSHA	Remark (OSHA)	OELs not established

- 8.2. Appropriate engineering controls**
 Appropriate engineering controls : Provide adequate general and local exhaust ventilation. Use process enclosures, local exhaust ventilation, or other engineering controls to control airborne levels below recommended exposure limits. Use explosion-proof equipment with flammable materials. Ensure adequate ventilation, especially in confined areas.

8.3. Individual protection measures/Personal protective equipment

Personal protective equipment symbol(s):



Personal protective equipment:

Gloves. Protective goggles. Protective clothing. Insufficient ventilation: wear respiratory protection.

Hand protection:

Use gloves chemically resistant to this material when prolonged or repeated contact could occur. Gloves should be classified and selected according to regional or national standards. Suggested glove materials are: Neoprene, Nitrile/butadiene rubber, Polyethylene, Ethyl vinyl alcohol laminate PVC, or vinyl. Suitable gloves should be recommended by the glove supplier.

Eye protection:

Wear eye protection, including chemical splash goggles and a face shield when possibility exists for eye contact due to spraying liquid or airborne particles

Skin and body protection:

Wear long sleeves, and chemically impervious PPE/coveralls to minimize bodily exposure.

Respiratory protection:

Use NIOSH (or other equivalent national standard) -approved dust/particulate respirator. Where vapour exceed PELs or other applicable OELs, use NIOSH-approved respiratory protective equipment.

SECTION 9: Physical and chemical properties

- 9.1. Information on basic physical and chemical properties**
- Physical state : Gas
 Color : Colourless
 Odor : Odorless
 Odor threshold : No data available
 pH : No data available

05/17/2022

Argon IG-01

Argon IG-01

Safety Data Sheet

according to Federal Register / Vol. 77, No. 58 / Monday, March 26, 2012 / Rules and Regulations

Melting point	: -189,2 °C
Freezing point	: No data available
Boiling point	: -185,9 °C
Flash point	: No data available
Relative evaporation rate (butylacetate=1)	: No data available
Flammability (solid, gas)	: No data available
Vapor pressure	: No data available
Relative vapor density at 20 °C	: No data available
Relative density	: 1,38 (air=1)
Density	: 0,001784 g/cm ³ at 0°C
Solubility	: 67 mg/l at 20 °C
Partition coefficient n-octanol/water (Log Pow)	: No data available
Auto-ignition temperature	: No data available
Decomposition temperature	: No data available
Viscosity, kinematic	: No data available
Viscosity, dynamic	: No data available
Explosive limits	: No data available
Explosive properties	: No data available
Oxidising properties	: No data available

9.2. Other information

No additional information available

SECTION 10: Stability and reactivity

10.1. Reactivity

No dangerous reactions known under normal conditions of use. In a fire or if heated, a pressure increase will occur and the container may burst.

10.2. Chemical stability

Stable under recommended handling and storage conditions (see section 7).

10.3. Possibility of hazardous reactions

None under normal use.

10.4. Conditions to avoid

Ignition sources. Heat. Open flame. Sparks.

10.5. Incompatible materials

None known.

10.6. Hazardous decomposition products

Under normal conditions of storage and use, hazardous decomposition products should not be produced.

SECTION 11: Toxicological information

11.1. Information on toxicological effects

Acute toxicity (oral)	: Not classified
Acute toxicity (dermal)	: Not classified
Acute toxicity (inhalation)	: Not classified
Skin corrosion/irritation	: Not classified
Serious eye damage/irritation	: Not classified
Respiratory or skin sensitisation	: Not classified
Germ cell mutagenicity	: Not classified
Carcinogenicity	: Not classified
Reproductive toxicity	: Not classified
STOT-single exposure	: Not classified
STOT-repeated exposure	: Not classified
Aspiration hazard	: Not classified
Viscosity, kinematic	: No data available

05/17/2022

Argon IG-01

Argon IG-01 Safety Data Sheet

according to Federal Register / Vol. 77, No. 58 / Monday, March 26, 2012 / Rules and Regulations

Symptoms/effects	: May displace oxygen and cause rapid suffocation. Unconsciousness.
Symptoms/effects after inhalation	: May displace oxygen and cause rapid suffocation. Unconsciousness.
Symptoms/effects after skin contact	: May cause skin irritation. Contact with the product may cause cold burns or frostbite.
Symptoms/effects after eye contact	: Direct contact with eyes is likely to be irritating. Contact with the liquid may cause frostbite and serious damage to eyes.
Symptoms/effects after ingestion	: May cause gastrointestinal irritation.

SECTION 12: Ecological information

12.1. Toxicity	No additional information available
12.2. Persistence and degradability	No additional information available
12.3. Bioaccumulative potential	No additional information available
12.4. Mobility in soil	No additional information available
12.5. Other adverse effects	Effect on global warming : No known effects from this product.

SECTION 13: Disposal considerations

13.1. Disposal methods	Waste treatment methods : Do not discharge to public wastewater systems without permit of pollution control authorities. No discharge to surface waters is allowed without an NPDES permit.
Product/Packaging disposal recommendations	: Do not allow the product to be released into the environment. Dispose in a safe manner in accordance with local/national regulations.

SECTION 14: Transport information

Department of Transportation (DOT)

In accordance with DOT

Transport document description (DOT)	: UN1006 Argon, 2.2
UN-No. (DOT)	: UN1006
Proper Shipping Name (DOT)	: Argon
Class (DOT)	: 2.2 - Class 2.2 - Non-flammable compressed gas 49 CFR 173.115
Hazard labels (DOT)	: 2.2 - Non-flammable gas



DOT Quantity Limitations Passenger aircraft/rail (49 CFR 173.27)	: 75 kg
DOT Quantity Limitations Cargo aircraft only (49 CFR 175.75)	: 150 kg
DOT Vessel Stowage Location	: A - The material may be stowed "on deck" or "under deck" on a cargo vessel and on a passenger vessel.
Emergency Response Guide (ERG) Number	: 121
Other information	: No supplementary information available.

Transportation of Dangerous Goods

Not applicable

Transport by sea (IMDG)

Transport document description (IMDG)	: UN 1006 ARGON, COMPRESSED, 2.2
UN-No. (IMDG)	: 1006
Proper Shipping Name (IMDG)	: ARGON, COMPRESSED

05/17/2022

Argon IG-01

Argon IG-01

Safety Data Sheet

according to Federal Register / Vol. 77, No. 58 / Monday, March 26, 2012 / Rules and Regulations

Class (IMDG) : 2 - Gases
 Limited quantities (IMDG) : 120 ml

Air transport (IATA)

Transport document description (IATA) : UN 1006 Argon, compressed, 2.2
 UN-No. (IATA) : 1006
 Proper Shipping Name (IATA) : Argon, compressed
 Class (IATA) : 2 - Gases

SECTION 15: Regulatory information

15.1. US Federal regulations

Argon IG-01

All chemical substances in this product are listed as "Active" in the EPA (Environmental Protection Agency) "TSCA Inventory Notification (Active-Inactive) Requirements Rule" ("the Final Rule") of Feb 2019, as amended Feb 2021 or are otherwise exempt, or regulated by other agencies such as FDA or FIFRA

SARA Section 311/312 Hazard Classes	Health hazard - Simple asphyxiant Physical hazard - Gas under pressure
-------------------------------------	---

15.2. International regulations

No additional information available

15.3. US State regulations

Component	State or local regulations
Argon(7440-37-1)	U.S. - New Jersey - Right to Know Hazardous Substance List; U.S. - Massachusetts - Right To Know List; U.S. - Pennsylvania - RTK (Right to Know) List

SECTION 16: Other information

Other information : Author: SS.

NFPA health hazard : 0 - Materials that, under emergency conditions, would offer no hazard beyond that of ordinary combustible materials.

NFPA fire hazard : 0 - Materials that will not burn under typical fire conditions, including intrinsically noncombustible materials such as concrete, stone, and sand.

NFPA reactivity : 0 - Material that in themselves are normally stable, even under fire conditions.

HMIS Hazard Rating

Health : 0

Flammability : 0

Physical : 0

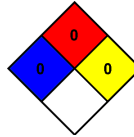

This information is based on our current knowledge and is intended to describe the product for the purposes of health, safety and environmental requirements only. It should not therefore be construed as guaranteeing any specific property of the product.

05/17/2022

Argon IG-01

16 Safety Data Sheet - IG-100 (Nitrogen)

16.1 SDS-Nitrogen



Nitrogen IG-100

Safety Data Sheet

according to Federal Register / Vol. 77, No. 58 / Monday, March 26, 2012 / Rules and Regulations

Issue date: 05/16/2022 Version: 1.0

SECTION 1: Identification

1.1. Identification
 Product form : Substance
 Substance name : Nitrogen IG-100

1.2. Recommended use and restrictions on use
 Use of the substance/mixture : Fire extinguishing agent

1.3. Supplier
 Viking Corporation
 210 N. Industrial Park Drive
 Hastings, MI 49058 - USA
 T 269-945-9501

1.4. Emergency telephone number
 Emergency number : ChemTel (Contract number MIS0006772) - USA and Canada: 1(800) 225-3924, International: +1(813) 248-0585

SECTION 2: Hazard(s) identification

2.1. Classification of the substance or mixture

GHS-US classification
 Press. Gas (Comp.) H280
 Simple Asphy S IAS

2.2. GHS Label elements, including precautionary statements

GHS US labelling
 Hazard pictograms (GHS US) : 

Signal word (GHS US) : Warning
 Hazard statements (GHS US) : H280 - Contains gas under pressure; may explode if heated.
 May displace oxygen and cause rapid suffocation.
 Precautionary statements (GHS US) : P410+P403 - Protect from sunlight. Store in a well-ventilated place.

2.3. Other hazards which do not result in classification
 No additional information available

2.4. Unknown acute toxicity (GHS US)
 Not applicable

SECTION 3: Composition/information on ingredients

3.1. Substances

Name	Product identifier	%
Nitrogen	(CAS-No.) 7727-37-9	100

3.2. Mixtures
 Not applicable

SECTION 4: First-aid measures

4.1. Description of first aid measures

First-aid measures general : If exposed or concerned, get medical attention/advice. Show this safety data sheet to the doctor in attendance. Wash contaminated clothing before re-use. Never give anything to an unconscious person.

First-aid measures after inhalation : IF INHALED: Remove to fresh air and keep at rest in a position comfortable for breathing. Get medical attention if breathing is affected. If breathing is difficult, supply oxygen.

05/17/2022 Nitrogen IG-100

Nitrogen IG-100

Safety Data Sheet

according to Federal Register / Vol. 77, No. 58 / Monday, March 26, 2012 / Rules and Regulations

First-aid measures after skin contact	: IF ON SKIN (or clothing): Remove affected clothing and wash all exposed skin with water for at least 15 minutes. If irritation develops or persists, get medical attention. Thaw frosted parts with lukewarm water. Do not rub affected area. Get immediate medical advice/attention.
First-aid measures after eye contact	: IF IN EYES: Immediately flush with plenty of water for at least 15 minutes. Remove contact lenses if present and easy to do so. Continue rinsing if pain, blinking, or irritation develops or persists, get medical attention. Continue rinsing. Thaw frosted parts with lukewarm water. Do not rub affected area. Get immediate medical advice/attention.
First-aid measures after ingestion	: IF SWALLOWED: rinse mouth thoroughly. Do not induce vomiting without advice from poison control center. Get medical attention if you feel unwell.

4.2. Most important symptoms and effects (acute and delayed)

Symptoms/effects	: May displace oxygen and cause rapid suffocation. Unconsciousness.
Symptoms/effects after inhalation	: May displace oxygen and cause rapid suffocation. Unconsciousness.
Symptoms/effects after skin contact	: May cause skin irritation. Contact with the product may cause cold burns or frostbite.
Symptoms/effects after eye contact	: Direct contact with eyes is likely to be irritating. Contact with the liquid may cause frostbite and serious damage to eyes.
Symptoms/effects after ingestion	: May cause gastrointestinal irritation.

4.3. Immediate medical attention and special treatment, if necessary

No additional information available

SECTION 5: Fire-fighting measures

5.1. Suitable (and unsuitable) extinguishing media

Suitable extinguishing media : Use extinguishing media appropriate for surrounding fire.

5.2. Specific hazards arising from the chemical

Fire hazard	: Non-flammable gas.
Explosion hazard	: Contains gas under pressure; may explode if heated.
Reactivity	: No dangerous reactions known under normal conditions of use. In a fire or if heated, a pressure increase will occur and the container may burst.

5.3. Special protective equipment and precautions for fire-fighters

Firefighting instructions	: Exercise caution when fighting any chemical fire. Do not dispose of fire-fighting water in the environment. Prevent human exposure to fire, fumes, smoke and products of combustion.
Protection during firefighting	: Do not enter fire area without proper protective equipment, including respiratory protection.

SECTION 6: Accidental release measures

6.1. Personal precautions, protective equipment and emergency procedures

General measures : Evacuate area. Keep upwind. Ventilate area. Spill should be handled by trained cleaning personnel properly equipped with respiratory and eye protection.

6.1.1. For non-emergency personnel

Protective equipment	: Wear Protective equipment as described in Section 8.
Emergency procedures	: Evacuate unnecessary personnel.

6.1.2. For emergency responders

Protective equipment : Wear suitable protective clothing, gloves and eye or face protection. For further information refer to section 8: "Exposure controls/personal protection".

6.2. Environmental precautions

Prevent entry to sewers and public waters. Notify authorities if liquid enters sewers or public waters. Avoid release to the environment.

6.3. Methods and material for containment and cleaning up

For containment	: Stop leak if safe to do so.
Methods for cleaning up	: Exclude sources of ignition and ventilate the area. Ground equipment electrically. Use explosion-proof equipment.

6.4. Reference to other sections

See Sections 8 and 13.

05/17/2022

Nitrogen IG-100

Nitrogen IG-100

Safety Data Sheet

according to Federal Register / Vol. 77, No. 58 / Monday, March 26, 2012 / Rules and Regulations

SECTION 7: Handling and storage

7.1. Precautions for safe handling

Precautions for safe handling : Do not handle until all safety precautions have been read and understood. Provide good ventilation in process area to prevent formation of vapour. Do not breathe gas. Wash hands and other exposed areas with mild soap and water before eating, drinking or smoking and when leaving work.

7.2. Conditions for safe storage, including any incompatibilities

Storage conditions : Keep container tightly closed. Store in a well-ventilated place. Keep cool. Store in a dry place.

SECTION 8: Exposure controls/personal protection

8.1. Control parameters

Nitrogen (7727-37-9)		
ACGIH	Remark (ACGIH)	TLV® Basis: Simple Asphyxiant
ACGIH	Regulatory reference	ACGIH 2022
OSHA	Remark (OSHA)	OELs not established

8.2. Appropriate engineering controls

Appropriate engineering controls : Provide adequate general and local exhaust ventilation. Use process enclosures, local exhaust ventilation, or other engineering controls to control airborne levels below recommended exposure limits. Use explosion-proof equipment with flammable materials. Ensure adequate ventilation, especially in confined areas.

8.3. Individual protection measures/Personal protective equipment

Personal protective equipment symbol(s):



Personal protective equipment:

Gloves. Protective goggles. Protective clothing. Insufficient ventilation: wear respiratory protection.

Hand protection:

Use gloves chemically resistant to this material when prolonged or repeated contact could occur. Gloves should be classified and selected according to regional or national standards. Suggested glove materials are: Neoprene, Nitrile/butadiene rubber, Polyethylene, Ethyl vinyl alcohol laminate PVC, or vinyl. Suitable gloves should be recommended by the glove supplier.

Eye protection:

Wear eye protection, including chemical splash goggles and a face shield when possibility exists for eye contact due to spraying liquid or airborne particles

Skin and body protection:

Wear long sleeves, and chemically impervious PPE/coveralls to minimize bodily exposure.

Respiratory protection:

Use NIOSH (or other equivalent national standard) -approved dust/particulate respirator. Where vapor, mist, or dust exceed PELs or other applicable OELs, use NIOSH-approved respiratory protective equipment.

SECTION 9: Physical and chemical properties

9.1. Information on basic physical and chemical properties

Physical state : Gas
 Color : Colorless
 Odor : Odorless
 Odor threshold : No data available
 pH : No data available

05/17/2022

Nitrogen IG-100

Nitrogen IG-100

Safety Data Sheet

according to Federal Register / Vol. 77, No. 58 / Monday, March 26, 2012 / Rules and Regulations

Melting point	: -210 °C
Freezing point	: No data available
Boiling point	: -195.8 °C
Flash point	: No data available
Relative evaporation rate (butylacetate=1)	: No data available
Flammability (solid, gas)	: No data available
Vapor pressure	: No data available
Relative vapor density at 20 °C	: No data available
Relative density	: No data available
Density	: 0.00125 g/cm ³ at 20°C
Molecular mass	: 28.01 g/mol
Solubility	: No data available
Partition coefficient n-octanol/water (Log Pow)	: No data available
Auto-ignition temperature	: No data available
Decomposition temperature	: No data available
Viscosity, kinematic	: No data available
Viscosity, dynamic	: No data available
Explosive limits	: No data available
Explosive properties	: No data available
Oxidising properties	: No data available

9.2. Other information

No additional information available

SECTION 10: Stability and reactivity

10.1. Reactivity

No dangerous reactions known under normal conditions of use. In a fire or if heated, a pressure increase will occur and the container may burst.

10.2. Chemical stability

Stable under recommended handling and storage conditions (see section 7).

10.3. Possibility of hazardous reactions

None under normal use.

10.4. Conditions to avoid

Ignition sources. Heat. Open flame. Sparks.

10.5. Incompatible materials

None known.

10.6. Hazardous decomposition products

Under normal conditions of storage and use, hazardous decomposition products should not be produced.

SECTION 11: Toxicological information

11.1. Information on toxicological effects

Acute toxicity (oral)	: Not classified
Acute toxicity (dermal)	: Not classified
Acute toxicity (inhalation)	: Not classified
Skin corrosion/irritation	: Not classified
Serious eye damage/irritation	: Not classified
Respiratory or skin sensitisation	: Not classified
Germ cell mutagenicity	: Not classified
Carcinogenicity	: Not classified
Reproductive toxicity	: Not classified
STOT-single exposure	: Not classified
STOT-repeated exposure	: Not classified
Aspiration hazard	: Not classified

05/17/2022

Nitrogen IG-100

Nitrogen IG-100

Safety Data Sheet

according to Federal Register / Vol. 77, No. 58 / Monday, March 26, 2012 / Rules and Regulations

Viscosity, kinematic	: No data available
Symptoms/effects	: May displace oxygen and cause rapid suffocation. Unconsciousness.
Symptoms/effects after inhalation	: May displace oxygen and cause rapid suffocation. Unconsciousness.
Symptoms/effects after skin contact	: May cause skin irritation. Contact with the product may cause cold burns or frostbite.
Symptoms/effects after eye contact	: Direct contact with eyes is likely to be irritating. Contact with the liquid may cause frostbite and serious damage to eyes.
Symptoms/effects after ingestion	: May cause gastrointestinal irritation.

SECTION 12: Ecological information

12.1. Toxicity

No additional information available

12.2. Persistence and degradability

No additional information available

12.3. Bioaccumulative potential

No additional information available

12.4. Mobility in soil

No additional information available

12.5. Other adverse effects

Effect on global warming : No known effects from this product.

SECTION 13: Disposal considerations

13.1. Disposal methods

Waste treatment methods : Do not discharge to public wastewater systems without permit of pollution control authorities. No discharge to surface waters is allowed without an NPDES permit.

Product/Packaging disposal recommendations : Do not allow the product to be released into the environment. Dispose in a safe manner in accordance with local/national regulations.

SECTION 14: Transport information

Department of Transportation (DOT)

In accordance with DOT

Transport document description (DOT)	: UN1066 Nitrogen, compressed, 2.2
UN-No.(DOT)	: UN1066
Proper Shipping Name (DOT)	: Nitrogen, compressed
Class (DOT)	: 2.2 - Class 2.2 - Non-flammable compressed gas 49 CFR 173.115
Hazard labels (DOT)	: 2.2 - Non-flammable gas



DOT Quantity Limitations Passenger aircraft/rail (49 CFR 173.27)	: 75 kg
DOT Quantity Limitations Cargo aircraft only (49 CFR 175.75)	: 150 kg
DOT Vessel Stowage Location	: A - The material may be stowed "on deck" or "under deck" on a cargo vessel and on a passenger vessel.
Emergency Response Guide (ERG) Number	: 121
Other information	: No supplementary information available.

Transport by sea (IMDG)

Transport document description (IMDG)	: UN 1066 NITROGEN, COMPRESSED, 2.2
UN-No. (IMDG)	: 1066
Proper Shipping Name (IMDG)	: NITROGEN, COMPRESSED
Class (IMDG)	: 2 - Gases
Limited quantities (IMDG)	: 120 ml

05/17/2022

Nitrogen IG-100

Nitrogen IG-100

Safety Data Sheet

according to Federal Register / Vol. 77, No. 58 / Monday, March 26, 2012 / Rules and Regulations

Air transport (IATA)

Transport document description (IATA) : UN 1066 Nitrogen, compressed, 2.2
 UN-No. (IATA) : 1066
 Proper Shipping Name (IATA) : Nitrogen, compressed
 Class (IATA) : 2 - Gases

SECTION 15: Regulatory information

15.1. US Federal regulations

Nitrogen IG-100

All chemical substances in this product are listed as "Active" in the EPA (Environmental Protection Agency) "TSCA Inventory Notification (Active-Inactive) Requirements Rule" ("the Final Rule") of Feb. 2019, as amended Feb. 2021, or are otherwise exempt or regulated by other agencies such as FDA or FIFRA

SARA Section 311/312 Hazard Classes	Health hazard - Simple asphyxiant Physical hazard - Gas under pressure
-------------------------------------	---

15.2. International regulations

No additional information available

15.3. US State regulations

Component	State or local regulations
Nitrogen(7727-37-9)	U.S. - Massachusetts - Right To Know List; U.S. - New Jersey - Right to Know Hazardous Substance List; U.S. - Pennsylvania - RTK (Right to Know) List

SECTION 16: Other information

Other information : Author: SS.

NFPA health hazard : 0 - Materials that, under emergency conditions, would offer no hazard beyond that of ordinary combustible materials.

NFPA fire hazard : 0 - Materials that will not burn under typical fire conditions, including intrinsically noncombustible materials such as concrete, stone, and sand.

NFPA reactivity : 0 - Material that in themselves are normally stable, even under fire conditions.

HMIS Hazard Rating

Health : 0

Flammability : 0

Physical : 0

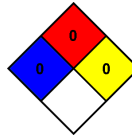

This information is based on our current knowledge and is intended to describe the product for the purposes of health, safety and environmental requirements only. It should not therefore be construed as guaranteeing any specific property of the product.

05/17/2022

Nitrogen IG-100

17 Component Product Sheets

17.1 Cylinder Assemblies

1. DESCRIPTION

The Oxeo system uses inert gas (Argon (IG-01) or Nitrogen (IG-100)) to extinguish a fire. The inert gas is stored in extinguishing agent cylinder(s) until system activation. The cylinder assembly includes:

- Seamless steel cylinder(s), available for both 2,901 PSI and 4,351 PSI at 59°F (15°C).
- Cylinder valve with burst disc, protective valve cap, and outlet venting safety plug.

The cylinders are designed, manufactured, and labeled in accordance with the UN ISO-9809-2 USA for use in the United States and Canada. They carry a NSW Workforce Approval from the manufacturer and can only be installed in the upright position.

An optional manual release assembly with pneumatic discharge pressure switch can be ordered separately for installation in the piping:

- The pneumatic discharge pressure switch is required with manual release installation per NFPA 2001.
- The status of the pressure switch can be monitored by the fire agent release control panel.

A cylinder label is attached to the extinguishing agent container:

- Contains maintenance and filling information, as well as information about the filling quantity.

Protective caps are used to protect the extinguishing agent cylinder's sensitive components (e.g., valves) from damage, such as during transport.

NOTE: The protective valve caps must be attached before each transport.

Standing extinguishing agent cylinders are for use with unistrut cylinder racking. Racking assembly setup is required before cylinders may be installed. See Viking unistrut racking tech data sheet F_040821 for more information.

2. LISTINGS AND APPROVALS



cULus Listed - EX5248 (Oxeo PR CF)



FM Approved: Oxeo PR CF

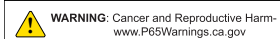

3. TECHNICAL DATA

Marking

See Figure 2 for label example.

Steel Cylinder Marking

- UN Model regulations for use and transport in the USA and Canada

Additional markings

Owner embossing

Ownership no. varies per order.

Ordering Information

The cylinders are filled according to the ordering designations. Extinguishant cylinders are completely assembled and filled. For a complete single container system, the following must be ordered separately: release devices, optional manual release assembly with pneumatic discharge pressure switch, discharge nozzles, hose or NPT connections, contact gauges, and warning signs. An approved release control panel with compatible detection system is also required.



Description*	Nominal Volume	Part no.
Oxeo Cylinder 4351 psi (300 bar) (Argon IG-01)	140 L	4001034
Oxeo Cylinder 4351 psi (300 bar) (Nitrogen IG-100)	140 L	4001054
Oxeo Cylinder 2901 psi (200 bar) (Argon IG-01)	80 L	4001024
Oxeo Cylinder 2901 psi (200 bar) (Nitrogen IG-100)	80 L	4001044
Oxeo Cylinder 4351 psi (300 bar) (Argon IG-01)	80 L	4001030
Oxeo Cylinder 4351 psi (300 bar) (Nitrogen IG-100)	80 L	4001050
Oxeo Cylinder 2901 psi (200 bar) (Argon IG-01)	30 L	4006190
Oxeo Cylinder 2901 psi (200 bar) (Nitrogen IG-100)	30 L	4006191
Oxeo Cylinder 4351 psi (300 bar) (Argon IG-01)	30 L	4006192
Oxeo Cylinder 4351 psi (300 bar) (Nitrogen IG-100)	30 L	4006193
<p>NOTE: To order cylinders in Canada, include the suffix "C" after any of the part numbers listed above (example: 4001024C)</p> <p>*All pressures at 59°F (15°C)</p>		

3.1 - Specifications and Ratings		
Parameter	Value	
	2901 psi (200 bar) Cylinder	4351 psi (300 bar) Cylinder
Extinguishing agents	Argon (IG-01) Nitrogen (IG-100)	
Agent purity	Minimum 99.9%	
Nominal System Pressure	2901 psi at 59 °F (200 bar at 15 °C)	4351 psi at 59 °F (300 bar at 15 °C)
Argon (IG-01) operating pressure at 70 °F (21 °C)	2988 psi (206 bar)	4511 psi (311 bar)
Nitrogen (IG-100) operating pressure at 70 °F (21 °C)	3002 psi (207 bar)	4496 psi (310 bar)
Operating temperature	-4 °F to 122 °F (-20 °C to +50 °C)	
Filling center	Purity cylinder gases	
Transport	See safety data sheets	
Valve Specifications*		
Pilot pressure of integrated pneumatic release device	Minimum: 116 psi (8 bar) Maximum: 5221 psi (360 bar)	
QRV-TD minimum flow cross-sectional area	0.1589 in ² (102.5 mm ²)	
*Valve type in accordance with EN12094-4: type 2 and ATR D2/11: type C (valve for multiple uses, maximum 100 releases)		

3.2 - Material standards	
Description	Material
Cylinder	Seamless steel, powder coated red RAL 3000
Valve housing, caps, plugs, misc. parts	Brass
Pilot valve, screws, closing piston, seal holder	Stainless steel
Seating seal, damper	PA6
Elastomer seal	EPDM
Springs	Stainless steel
Bust disk device	Nickel, copper alloy
Protective cap	DIN EN ISO 11117, large version
Thread	DIN EN ISO 11117, W80
Thread, cylinder valve	ISO 11363-1, 25E
Tested overpressure	6,526 PSI (450 bar)

**NOTICE: ALL DIMENSIONS SHOWN IN THIS FIGURE ARE APPROXIMATE.
VARIATIONS DUE TO MANUFACTURING AND INSTALLATION TOLERANCES ARE POSSIBLE.**

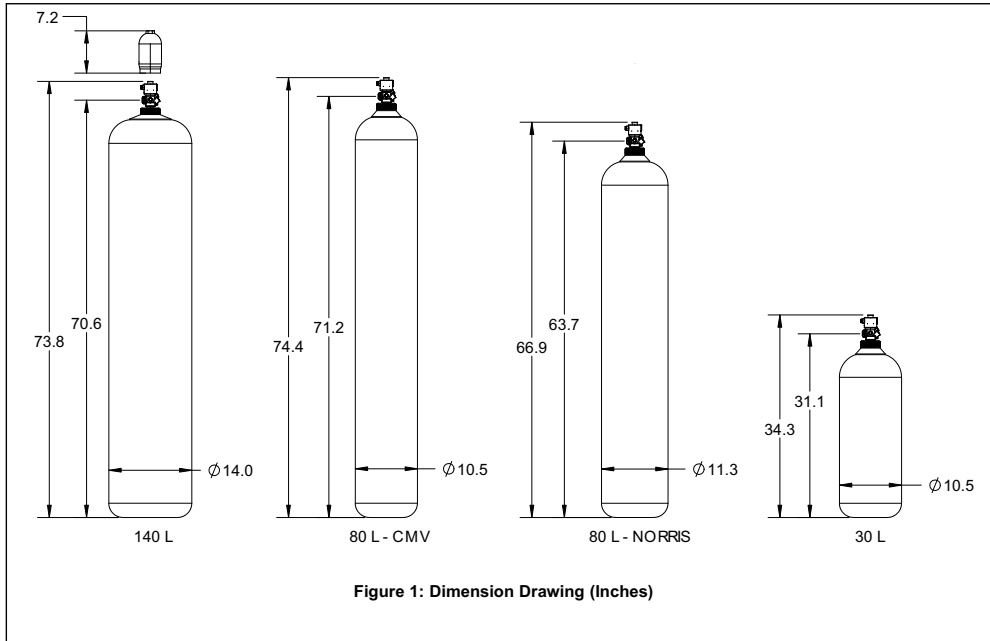

Note: Contact Viking Corp for the most applicable 80 L size.

**NOTICE: ALL DIMENSIONS SHOWN IN THIS FIGURE ARE APPROXIMATE.
VARIATIONS DUE TO MANUFACTURING AND INSTALLATION TOLERANCES ARE POSSIBLE.**

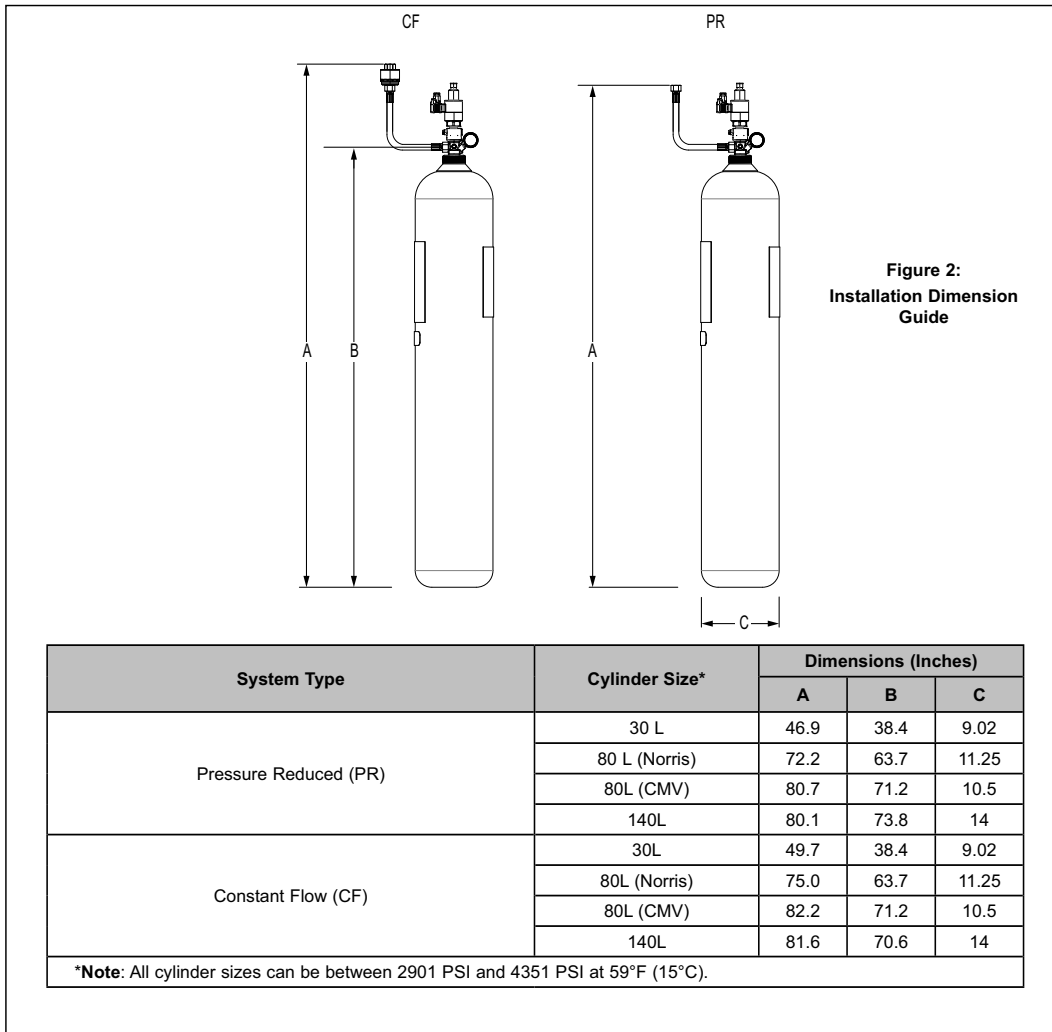

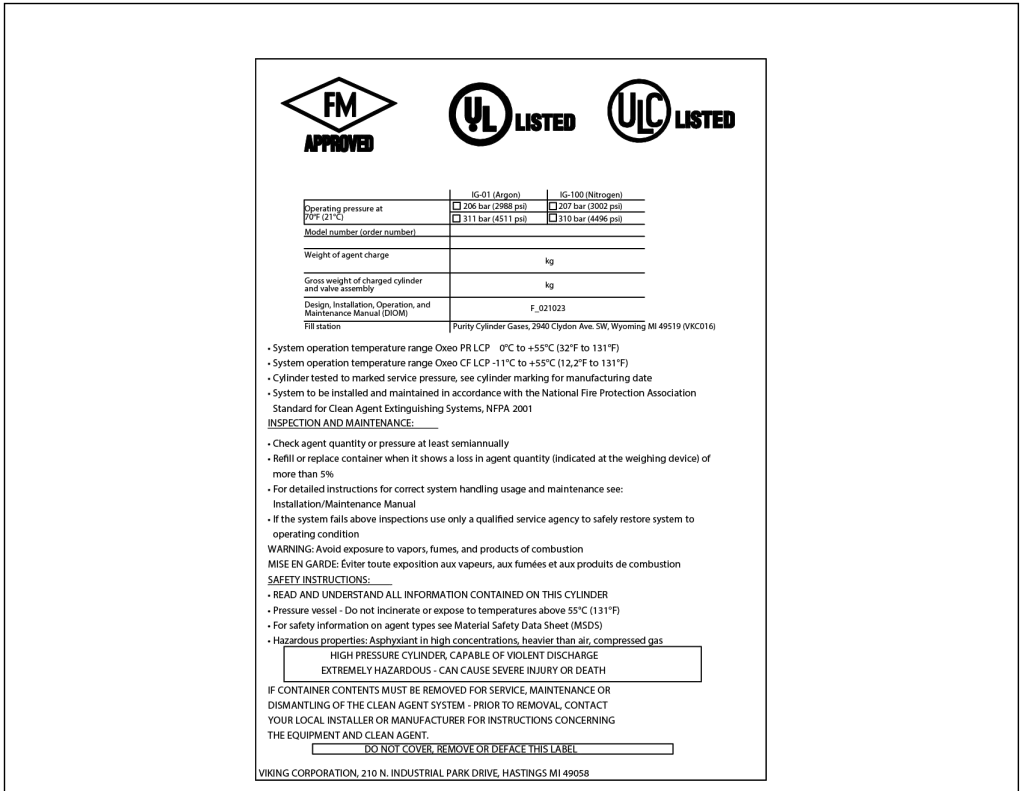

Figure 3: Cylinder Label

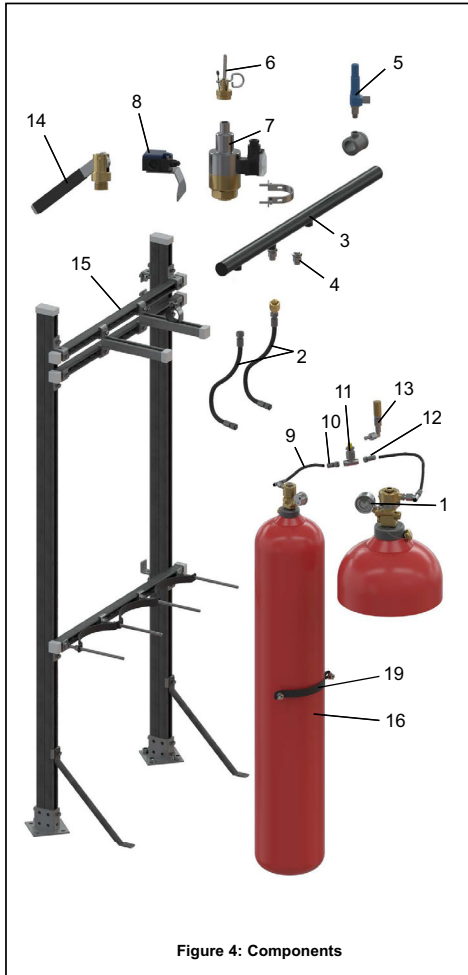

TABLE 1: OXEXO EXTINGUISHING SYSTEM COMPONENTS			
Ref.	Description		Part No.
1	Contact Pressure Gauge / Low Pressure Switch (N.C. under pressure)	2,901 PSI (200 bar)	927615
		4,351 PSI (300 bar)	927617
	Contact Pressure Gauge / Low Pressure Switch (N.O. under pressure)	2,901 PSI (200 bar)	927612
		4,351 PSI (300 bar)	927616
2	Hose	14.8 in. (375 mm)	934921D
		23.6 in. (600 mm)	921922D*
	CF Hose Kit	14.8 in. (375 mm)	25763
		23.6 in. (600 mm)	25764*
3	PR Manifold Assemblies	2 out	25528
	2" NPT	3 out	25054
	CF Manifold Assemblies 2" NPT	2 out	25759
4	Check valve (CF only)	2 out	25760
		3 out	25760
		Check valve cap (not shown)	
5	Manifold Pressure Relief Device	2,901 PSI (200 bar)	885136D
		4,351 PSI (300 bar)	886281D
		957 PSI (65 bar) (CF only)	888007D
6	Manual Release Device		914028
7	Electrical Release Device		914027D
8	Electrical Release Device Monitor		930865D
9	Pilot Hose (Kit available with fittings included)	20" (500 mm)	24467 (25132)
		39" (1,000 mm)	24468 (25133)
		59" (1,500 mm)	24469 (25134)
10	Pilot Hose Adapter		125566
11	Pilot Tee		912487
12	Pilot Coupler		125920
13	Pressure Relief Safety Assembly		24498
	Pressure Relief Safety Assembly with manual release		24499
14	Reset Tool		934652
15	Unistrut Racking Assembly		Varies
16	Extinguishing Agent Cylinder		Varies
17	Hose Bend Radius Tool (for #2) (Not shown)		26412
18	Hose Bend Radius Tool (for #9) (Not shown)		26408
19	Cylinder brackets (30L/80L)		24196W/B
	Cylinder brackets (140L)		26449W/B

*Special order; contact sales team for lead time

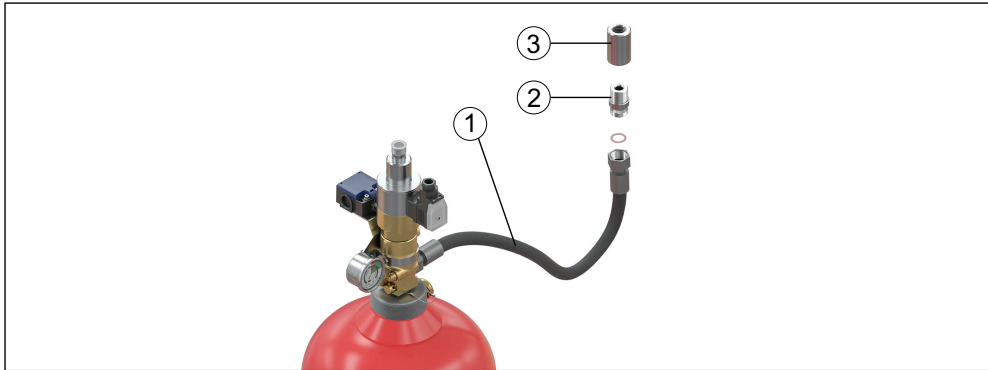

Figure 5: Cylinder Connection Components (PR)

TABLE 3: SYSTEM COMPONENTS REQUIRED FOR AN OXEO SINGLE CONTAINER SYSTEM - PR ONLY		
Item No.	Description	Part numbers
1	Discharge hose	934921D or 934922D
2	Adapter	887706
3	Pressure Reducer	25011* or 25012*
4	Hose Bend Radius Tool (not shown)	26412
*Base part numbers shown. For complete part numbers, refer to the Viking pressure reducer technical data sheet.		
NOTE: Single tank components are sold separately.		

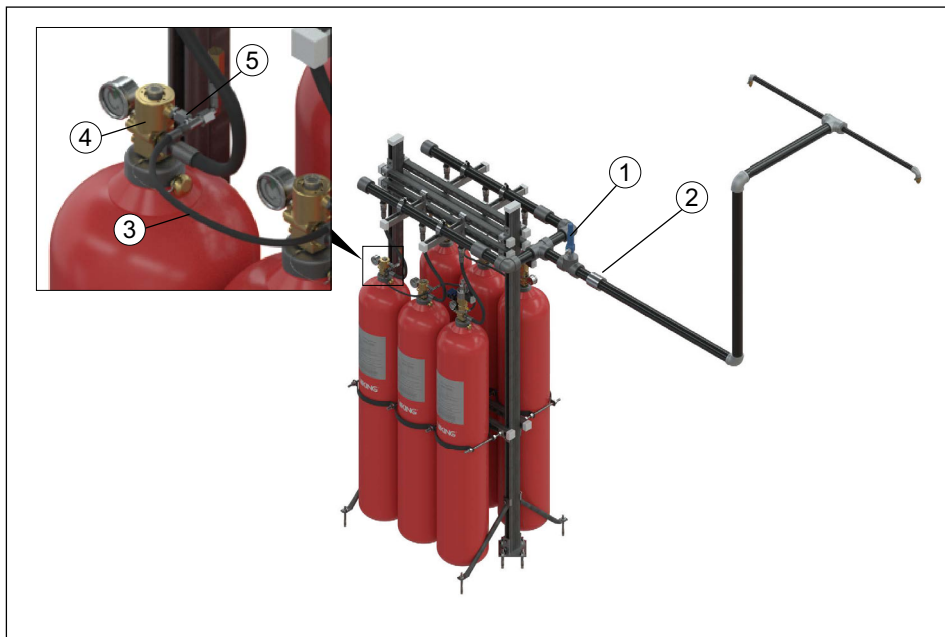

Figure 6: Additional Connection Components for Multiple Container System (PR)

TABLE 4: ADDITIONAL SYSTEM COMPONENTS REQUIRED FOR AN OXEO PR MULTIPLE CONTAINER SYSTEM	
Item No.	Description
1	Manifold pressure relief
2	Pressure reducer
3	Pilot line
4	Valve with integrated pneumatic release device
5	Pilot line kit*
6	Hose bend radius tool (related to #5) (not shown)

*A pilot line kit is needed to connect each pilot cylinder. One (1) kit is required for each pneumatic pilot system.

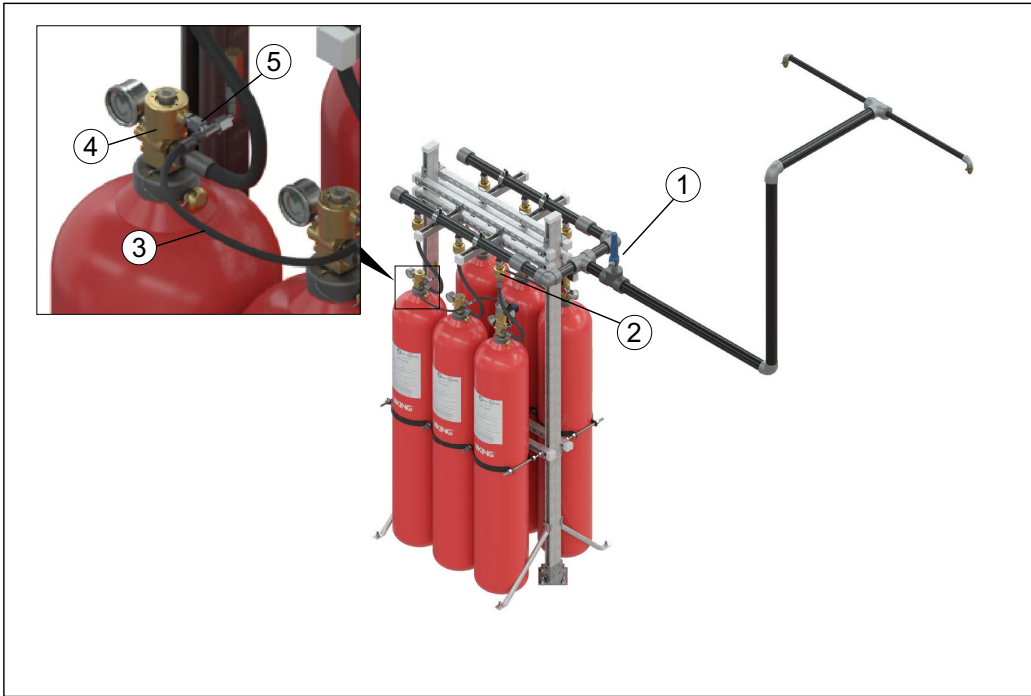

Figure 7: Additional Connection Components for Multiple Container System (CF)

TABLE 4: ADDITIONAL SYSTEM COMPONENTS REQUIRED FOR AN OXEO CF MULTIPLE CONTAINER SYSTEM	
Item No.	Description
1	Manifold pressure relief
2	Pressure regulator
3	Pilot line
4	Valve with integrated pneumatic release device
5	Pilot line kit*
6	Hose bend radius tool (related to #5) (not shown)

*A pilot line kit is needed to connect each pilot cylinder. One (1) kit is required for each pneumatic pilot system.

17.2 Pilot Cylinders

1. DESCRIPTION

The Oxexo inert gas fire extinguishing system uses nitrogen stored in the system's pilot container(s) until system activation. The container assembly includes a seamless steel cylinder filled with nitrogen gas, assembled with the following components:

- Cylinder valve with burst disc, protective valve cap and outlet venting safety plug.
- The cylinder is available for a 2901 psi (200 bar) pressure rating.
- Cylinders are designed, manufactured, and labeled in accordance with the UN ISO-9809_2 USA for use in the United States and Canada.
- Cylinders can only be installed in the upright position.

An optional manual release assembly with pneumatic discharge pressure switch can be ordered separately for installation in the piping:

- The pneumatic discharge pressure switch is required with manual release installation per NFPA 2001.
- The status of the pressure switch can be monitored by the fire agent release control panel.

A cylinder nameplate label is attached to the extinguishing agent container:

- Contains maintenance and filling information, as well as information about the filling quantity
- Protective caps are used to protect sensitive components (e.g. valves) of the extinguishing agent containers:

NOTE: The protective valve cap and outlet venting safety plug must be attached before each transport.

Standing extinguishing agent cylinders are for use with unistrut cylinder racking. Racking assembly setup is required before cylinders may be installed.



Designation	Nominal Volume	Part no.
Oxexo Pilot Cylinder 2901 psi	80 L	4003404
Oxexo Pilot Cylinder 2901 psi	30 L	4006215

2. LISTINGS AND APPROVALS



cULus Listed - EX5248 (Oxexo PR CF)



FM Approved: Oxexo PR CF



3. TECHNICAL DATA

Marking

See Figure 2 for nameplate example.

Steel Cylinder Marking

- UN Model regulations for use and transport in the USA and Canada

Additional marking

Owner embossing

Ordering Information

The cylinders are filled according to the ordering designations. Pilot cylinders are completely assembled and filled. For a complete system, the following must be ordered separately: release devices, optional manual release assembly with pneumatic discharge pressure switch, discharge nozzles, hose or NPT connections, contact gauges, and warning signs. An approved release control panel with compatible detection system is also required.

3.1 - Specifications and Ratings	
Parameter	Value
Pilot gas	Nitrogen (99.9% agent purity minimum)
Nominal System Pressure	2901 psi at 59 °F (200 bar at 15 °C)
Nitrogen operating pressure at 70 °F (21 °C)	3002 psi (207 bar)
Operating temperature	-4 °F to 122 °F (-20 °C to +50 °C)
Filling center	Purity cylinder gases
Transport	See safety data sheets
Valve Specifications*	
Pilot pressure of integrated pneumatic release device	Minimum: 116 psi (8 bar) Maximum: 5221 psi (360 bar)
QRV-TD minimum flow cross-sectional area	0.1589 in ² (102.5 mm ²)

*Valve type in accordance with EN12094-4: type 2 and ATR D2/11: type C (valve for multiple uses, maximum 100 releases)

3.2 - Material standards	
Description	Material
Cylinder	Seamless steel, powder coated red RAL 3000
Valve housing, caps, plugs, miscellaneous parts	Brass
Pilot valve, screws, closing piston, seal holder	Stainless steel
Seating seal, damper	PA6
Elastomer seal	EPDM
Springs	Stainless steel
Burst disk device	Nickel, copper alloy
Protective cap	DIN EN ISO 11117, large version
Thread	DIN EN ISO 11117, W80
Thread, cylinder valve	ISO 11363-1, 25E
Tested overpressure	6526 psi (450 bar)

**NOTICE: ALL DIMENSIONS SHOWN IN THIS FIGURE ARE APPROXIMATE.
VARIATIONS DUE TO MANUFACTURING AND INSTALLATION TOLERANCES ARE POSSIBLE.**

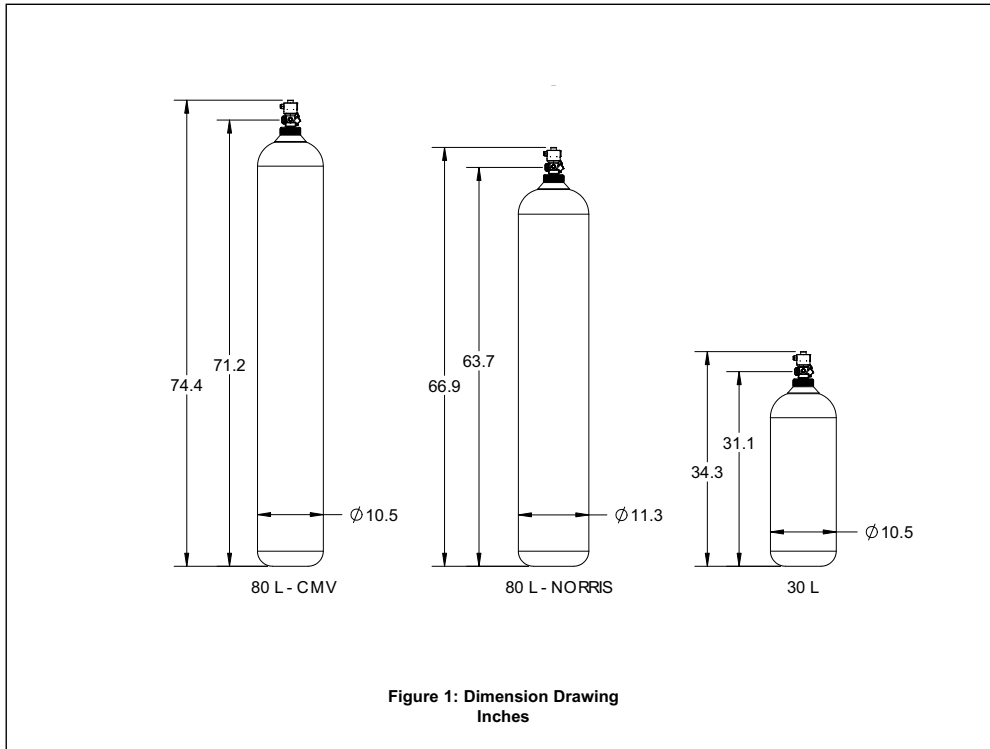

Note: Contact Viking Corp for the most applicable 80 L size.

Figure 3: Pilot Cylinder Label

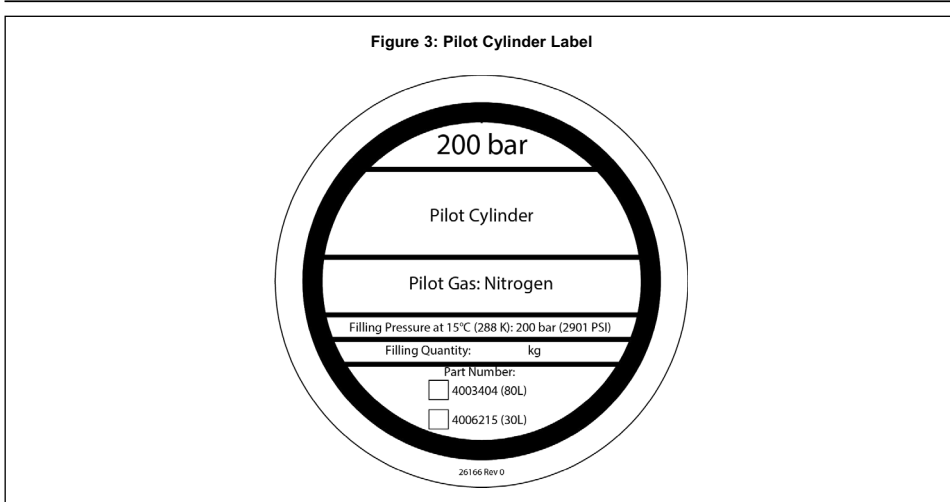

NOTE: French and Spanish versions of the label above are located on the opposite side of the pilot cylinder.

17.3 Manifolds

1. DESCRIPTION

The Viking Oxexo manifolds have a maximum working pressure of 5294 psi (365 bar) for PR and 920 psi (63.4 bar) for CF. Manifolds are mounted directly on the cylinder rack to connect every extinguishing agent cylinder with the pipe network.

The manifolds are manufactured with two and three inlets. A maximum of 18 inlets can be assembled in one row (see racking instruction in the Oxexo manuals for details). Each inlet is equipped with a check valve which releases the extinguishing agent in flow direction and prevents the flow in the opposite direction.

2. LISTINGS AND APPROVALS



cULus Listed - EX5248 (Oxexo PR CF)



FM Approved: Oxexo PR CF

NOTE: Only the check valve carries UL and FM approvals. The manifolds are considered standard pipe and do not need lab approval.

3. TECHNICAL DATA

Specifications:

Operating medium: Argon (IG-01), Nitrogen (IG-100)

Nominal diameter:

Pipe: 2"

Check valve: 3/4"

Working pressure: PR - 5294 psi (365 bar); CF - 920 psi (63.4 bar)

Test pressure: PR - 7948 psi (548 bar); CF - 1500 psi (103.4 bar)

Temperature range: -4 °F to 122 °F (-20 °C to +50 °C)

Screw coupling: gas tight

Finish:

Pipe: Steel, E-coated black

Check valve: Steel, chemically nickel-plated

NOTE: All technical data for the manifold assembly is as specified in NFPA 2001.

Specifications for check valve:

Nominal diameter: DN12

Free cross-sectional area: 0.14 square inch (92 mm²)

Working pressure: 5294 psi (365 bar)

Test pressure: 7948 psi (548 bar)

Pressure to open 1.45 psi (less than 0.1 bar)

Leak rate at 290 psi (20 bar): less than 20 bubbles per minute

Temperature change: -4 °F to 122 °F (-20 °C to +50 °C)

Check valve: complies with EN 12094-13

Material standards:

Housing: steel, chemically nickel-plated

Ball: stainless steel

Sealing: thermoplastic



Designation	Part no.
Oxexo manifolds	Refer to table



3.1 - Specifications		
Designation		Part no.
Manifold PR (30 L/80 L)	2 outlets	25528
	3 outlets	25054
Manifold CF (30 L/80 L)	2 outlets	25759
	3 outlets	25760
Manifold PR (140 L)	2 outlets	26722
	3 outlets	26729
Manifold CF (140 L)	2 outlets	26704
	3 outlets	26712

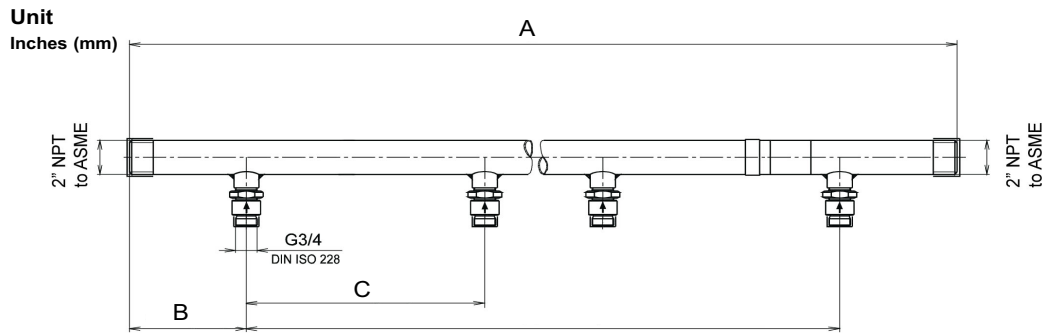

Figure 1: Dimensions

Description	Outlets	Liters	5Dimension A	Dimensions B	Dimensions C
Manifold	2	30/80	21.75	5.00	11.75
	2	140	29.75	7.00	15.75
	3	30/80	33.50	5.00	11.75
	3	140	45.50	7.00	15.75

17.4 Check Valve

1. DESCRIPTION / FUNCTION

The Oxexo check valve releases the extinguishing agent in the correct flow direction and prevents flow in the opposite direction. It is installed between the cylinder valve and the manifold. The check valve may be used only in accordance with Oxexo system.

2. LISTINGS AND APPROVALS

 cULus Listed - EX5248 (Oxexo PR CF)

 FM Approved: Oxexo PR CF

3. TECHNICAL DATA

Specifications

Operating medium: argon (IG-01), nitrogen (IG-100),
 Nominal diameter: DN12
 Free cross-sectional area: 0.14 square inch (92 mm²)
 Working pressure: 5294 psi (365 bar)
 Test pressure: 7948 psi (548 bar)
 Pressure to open: 1.45 psi (< 0.1 bar)
 Leak rate at 290 psi (20 bar): ≤ 20 bubbles / 1 min
 Temperature range: -4 °F to 122 °F (-20 °C to 50 °C)

Material standards

Housing: steel, chemically nickel-plated
 Ball: stainless steel
 Sealing: thermoplastic



Designation	Part no.	Weight
Check valve	886030	0.66 lbs (0.30 kg)

 **WARNING:** Cancer and Reproductive Harm-
www.P65Warnings.ca.gov

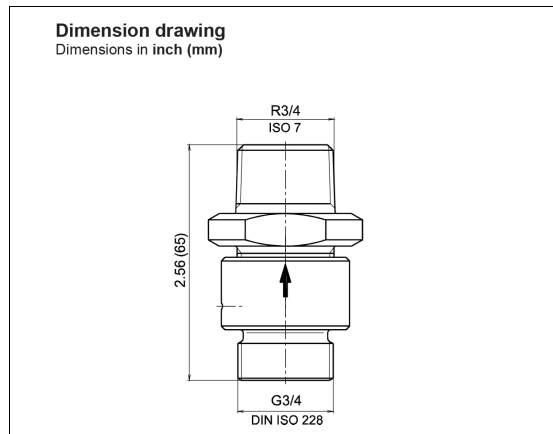

17.5 Check Valve Cap

1. DESCRIPTION / FUNCTION

The check valve cap assembly is installed in unused Oxexo manifold check valve connections.

2. LISTINGS AND APPROVALS

 cULus Listed - EX5248 (Oxexo PR CF)

 FM Approved: Oxexo PR CF

3. TECHNICAL DATA

Specifications

Working pressure: 7948 psi (548 bar)

Material Standards

Material: Steel

Finish: Galvanized

Marking: Material, batch, manufacturer's sign



Designation	Part no.
Oxexo Check Valve Cap Assembly	886042D

 WARNING: Cancer and Reproductive Harm - www.P65Warnings.ca.gov

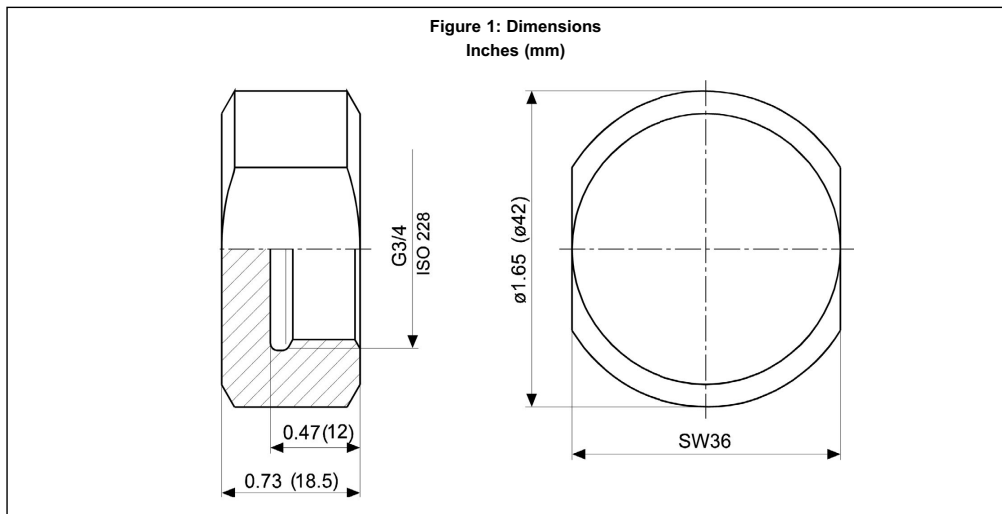

17.6 Discharge Hose Kits (PR and CF)

1. DESCRIPTION

The discharge hose kits must only be used in accordance with system approval in argon, nitrogen and carbon dioxide fire extinguishing systems.

The hose is used to connect the extinguishing agent cylinder with the manifold, or rather the check valve.

2. LISTINGS AND APPROVALS



cULus Listed - EX5248 (Oxeo PR CF)



FM Approved: Oxeo PR CF

3. TECHNICAL DATA

Specifications

Operating mediums	argon (IG-01) and nitrogen (IG-100)
Nominal diameter	DN12
Bending radius	≥ 5.1 inches (130 mm)
Temperature range	-40 to 122 °F (-40 to 50 °C)
Working pressure	5294 psi (365 bar)
Test pressure	7948 psi (548 bar)
Bursting strength	min 15882 psi (1095 bar)
Hose (type 1 connection)	complies with EN 12094-8 CE conformity according to Construction Products Regulation (EU) No. 305/201 NFPA tests according to NFPA 12 and NFPA 2001, pressure tested to 100%
Gasket material	Vulcanized fiber



Description	Part Numbers	Dimensions
Discharge Hose (with two Gaskets)	934921D	14.76 in (375 mm)
Discharge Hose (with two Gaskets)	934922D	23.62 in (600 mm)
Bend Radius Tool	26412	5.12 in (130 mm)
Flat Gasket (for Cylinder)	149970	0.728 in x 0.512 in x .079 in (18.5 mm x 13 mm x 2 mm)
Gasket (for Check Valve)	149890	0.906 in x 0.551 in x 0.079 in (23 mm x 14 mm x 18.5 mm)

Dimensions: inch (mm)

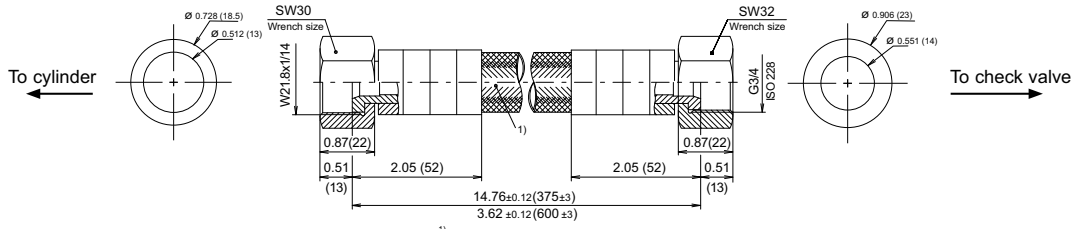

17.7 Discharge Hose Kit (CF Only)

1. DESCRIPTION

The Viking Oxexo hose must only be used in accordance with system approvals. The hose is used to connect the extinguishing agent cylinder with the check valve on the manifold.

The pressure control valve is specifically intended for constant flow (CF) inert-gas extinguishing systems. Once installed between the hose and the manifold, the pressure reducer serves to reduce the extinguishing agent container pressure from 200 bar (2900 psi) or 300 bar (4350 psi) to a lower pressure level for downstream system areas. The hose kit includes the hose, gaskets, and constant flow regulator.



2. LISTINGS AND APPROVALS

cULus Listed - EX5248 (Oxexo CF)



FM Approved: Oxexo CF



3. TECHNICAL DATA

Hose Specifications

Operating mediums argon (IG-01), nitrogen (IG-100)

Nominal diameter DN12
 Bending radius ≥ 5.1 inches (130 mm)
 Temperature range -40 to 122 °F (-40 to 50 °C)
 Working pressure 5294 psi (365 bar)
 Test pressure 7948 psi (548 bar)
 Bursting strength minimum 15882 psi (1095 bar)
 Hose (type 1 connection) complies with EN 12094-8
 CE conformity according to Construction Products Regulation (EU) No. 305/2011 NFPA tests according to NFPA 12 and NFPA 2001, pressure tested to 100%
 Gasket material Vulcanized fiber

Pressure Reducer Specifications

Operating mediums argon (IG-01), nitrogen (IG-100)

Working pressure maximum 5220 psi (360 bar)
 Static output pressure 870 ^{+29/-87} psi (60 ^{+2/-6} bar)
 Dynamic output pressure maximum 870 psi (60 bar)
 Temperature range -4 to 122 °F (-20 to 50 °C)
 Nominal diameter 0.47 in. (12 mm)
 Minimum outlet nozzle diameter 0.12 in. (3 mm)
 Assembly torque range 3.7 - 40.6 ft-lb (5 -55 Nm)
 Weight approx. 3.95 lbs (1.75 kgs)

Designation	Part no.
Constant flow hose kit 14.8"	25763
Constant flow hose kit 23.6"	25764
Bend Radius Tool	26412



Materials
 Pressure-bearing components, including enclosure Brass, stainless steel
 Seal materials EPDM, PUR, PA

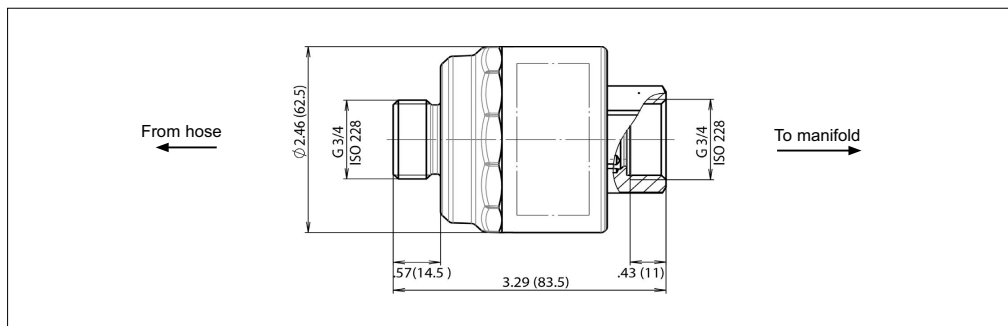
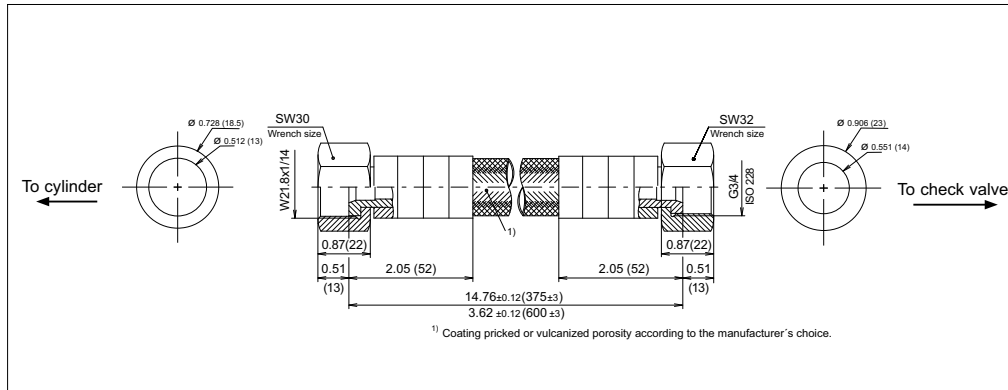

17.8 Pneumatic Limit Switch

1. DESCRIPTION

For Viking Oxeo Fire Extinguishing Systems, when a manual release device is installed, a pneumatically actuated limit switch (pressure switch) is required on the pipeline to indicate a release per NFPA 2001.

- As extinguishing agent enters the pipeline, the pressure of the agent opens or closes the floating contacts of the limit switch (depending on whether it is set for N.O. or N.C. operation).
- The status of this contact can be monitored by the agent release control panel.
- The dry contacts can be used for different purposes, triggered via the pneumatic discharge pressure switch when connected electronically to the detection system.
- These dry contacts can be used for alarm notification, shutting dampers, closing doors, etc.
- The pushbutton on the pneumatic discharge pressure switch is for testing purposes.
- The pilot line hose connects the pneumatic discharge pressure switch to the pipeline.

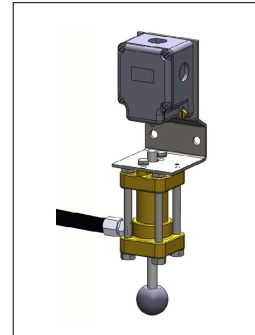

2. LISTINGS AND APPROVALS



UL Listed - EX5248 (Oxeo PR, Oxeo CF)



FM Approved (Oxeo PR, Oxeo CF)

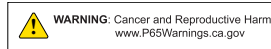

3. TECHNICAL DATA

Specifications - Part Number 826758D

Discharge Pressure Switch:

- Switch System: 2 adjustable contacts
- Contact Types:
 - Standard setting is 2 normally open (NO)
 - Can be set for 2 normally closed (NC)
- Working Pressure: 2030 psi (140 bar)
- Maximum Rated Voltage: 500V
- Maximum Rated Current: 16A
- IP 65 Enclosure
- Temperature range: -4 °F to 122 °F (-20 °C to +50 °C)

NOTE: Pneumatic limited switch must be assembled on the low-pressure pipe network (for PR systems only).

Material Standards

Discharge Pressure Switch:

- Housing: Alloy die-cast metal
- Bracket: Steel
- Bolts: Zinc plated steel
- Cylinder: Brass
- Contact Material: Silver
- Pushbutton: Plastic
- Hose: Rubber hydraulic hose with galvanized steel ends
- Hose Adapters: Galvanized steel

NOTE: The Pneumatic Discharge Pressure Switch is factory set for NO operation. It may be switched to NC operation: Use a flathead screwdriver to remove the switch cover and adjust the two contacts. Verify that the switch is set for NC operation and then replace the switch cover.

TABLE 1: PART NUMBERS

Description	Part No.
Pneumatic Limit Switch	826758D

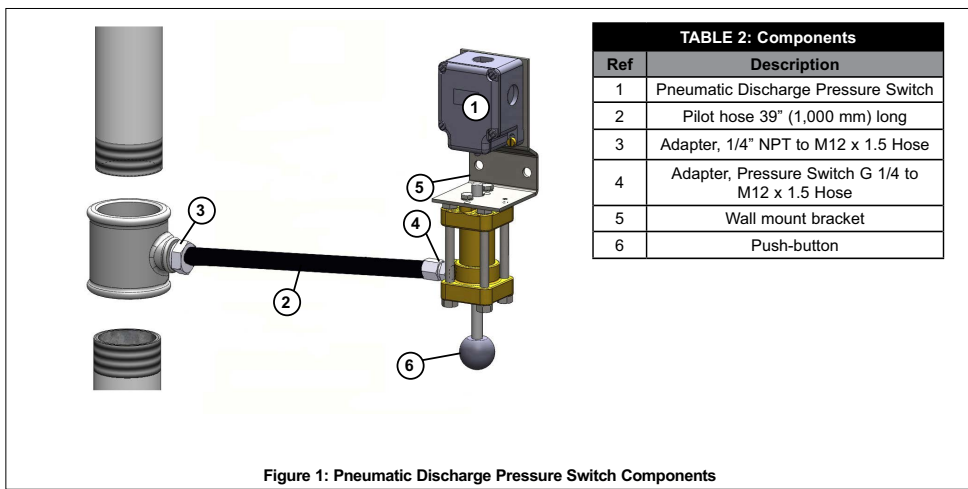

Figure 1: Pneumatic Discharge Pressure Switch Components

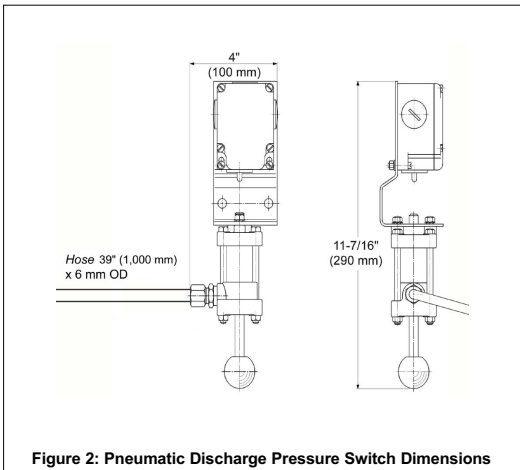

Figure 2: Pneumatic Discharge Pressure Switch Dimensions

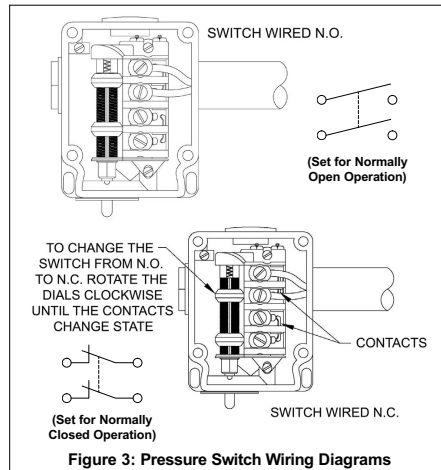

Figure 3: Pressure Switch Wiring Diagrams

17.9 Pilot Hoses

1. DESCRIPTION

Viking Oxexo Fire Extinguishing Systems use pilot hoses to connect the valve of the master extinguishing agent cylinder and the pneumatic release devices of other extinguishing agent cylinders; two (2) pneumatically actuated release devices; or the pneumatic release device (PAE) and the pneumatic pilot pipes of multi-zone systems. An adapter kit is needed to connect the pilot hose to the cylinders.

2. LISTINGS AND APPROVALS



cULus Listed - EX5248 (Oxexo PR CF)



FM Approved: Oxexo PR CF



*Listed as a component of a OXEO PR CF Clean Agent Fire Extinguishing System



WARNING: Cancer and Reproductive Harm-
www.P65Warnings.ca.gov

3. TECHNICAL DATA

Specifications

- Operating Medium: Argon (IG-01) and Nitrogen (IG-100)
- Nominal Diameter: 1/16" (DN4)
- Operating Temperature Range: -4 °F to 131 °F (-20 °C to 55 °C)
- Minimum Bend Radius: 2" (51 mm)
- Working Pressure: 5,439 psi (375 bar)
- Test Pressure: 8,166 psi (563 bar)
- Burst Pressure: 16,317 psi (1,125 bar)
- Ferrule: AOL Conical Nipple 24° with O-ring (DKOL)

Material Standards

- Rubber hydraulic hose with galvanized steel ends
- M12x1.5 Union (2)

Ordering Information: Refer to Table 1.

Description		Part No.*	Weight lbs (kg)
Pilot Line Hoses			
OXEO	20" (600 mm) long	24467	0.77 (0.35)
	39" (1,000 mm) long	24468	0.90 (0.41)
	59" (1,500 mm) long	24469	1.34 (0.61)
	Adapter kit, 20"	25132	n/a
	Adapter kit, 39"	25133	n/a
	Adapter kit, 59"	25134	n/a
	Bend Radius Tool	26408	n/a

*Interchangeable with part numbers 911008, 911024 and 911025
(Not for VdS / CE / CNBOP)

4. MAINTENANCE

Always check pilot hoses during routine maintenance for any residue and clean, if necessary. Only use clean pilot hoses in the system. Contaminated pilot hoses can cause the system to malfunction. This can cause severe injuries and significant material and system damage.

! *Due to deterioration of the material, the hose must be replaced by a new one at the latest after 10 years. See marking "date of manufacture" (month/year) on the hose.*

1. Check the hose visually for external damage, corrosion at the armatures, cracks in the plastic coating and fouling.
2. Remove fouling with a damp cloth.

! *Cleaning agents that attack plastics, rubber, or metals must not be used under any circumstances.*

3. In case of damage, corrosion or cracks replace the hose immediately.

! *A repair is **NOT** recommended.*

4. Check that the hexagonal cap nuts are tight and retighten by means of a suitable tool or spanner if necessary.
5. Check that the bending radius of the hose is greater than the minimum bending radius.
6. Check that the hose is fitted without torsion.

If the hose must be replaced, follow the steps below for disassembly:

1. Loosen one of the hexagonal cap nuts slightly by means of a suitable tool or spanner (turn counterclockwise).
⇒ If a hissing sound can be heard there is residual pressure in the hose.
2. Wait until the hose is depressurized.
3. Loosen the hexagonal cap nut completely and also the second hexagonal cap nut by means of a suitable tool or spanner (turn counterclockwise).

17.10 Manifold Pressure Relief (957 psi)

1. DESCRIPTION / FUNCTION

The Oxexo manifold pressure relief devices operate to ensure the safety of the Oxexo inert gas fire protection system. The pressure reliefs are installed in-line with the manifold to ensure that the pressure does not increase to a level that would rupture the system piping.

2. LISTINGS AND APPROVALS



cULus Listed - EX5248 (Oxexo CF)



FM Approved: Oxexo CF

3. TECHNICAL DATA

Specifications

Type: 4373.2602

Operating medium: Argon (IG-01), Nitrogen (IG-100)

Operating temperature: 0° F to 122 °F (-18 °C to 50 °C)

Response pressure: 957 psi (66 bar) at 122 °F (50 °C)

Valve seat: metal seal

Thread: G1/8 ISO228 converted to 1/2" NPT

Orientation of device: Vertical

Gaseous flow rate: Argon (IG-01) - 1720 Nm³; Nitrogen - 1942 Nm³

Safety valve according to Pressure Equipment Directive 97/23/EC Category IV



Designation	Part no.	Weight
Safety Valve 957 psi	888007D	2.65 lbs (1.2 kg)



WARNING: Cancer and Reproductive Harm-
www.P65Warnings.ca.gov

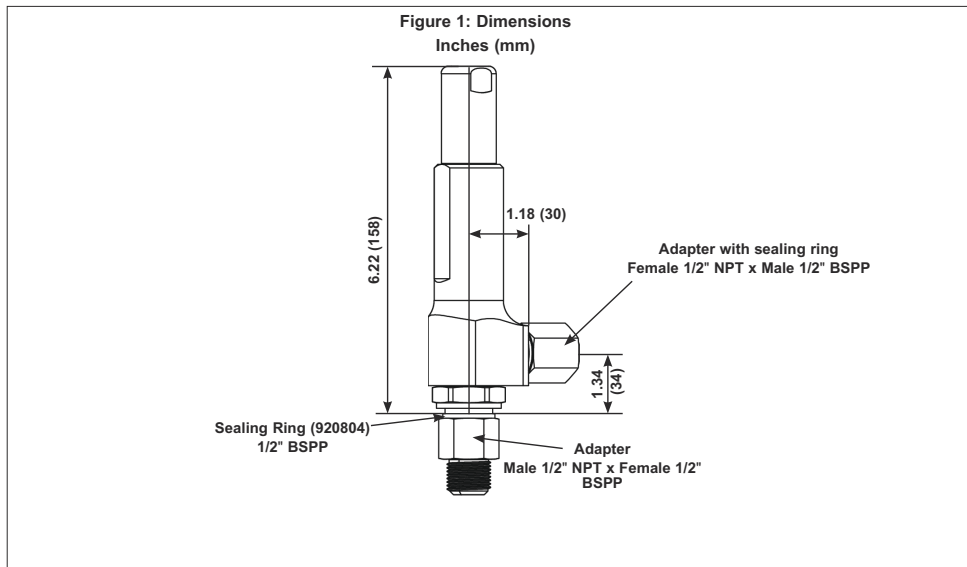

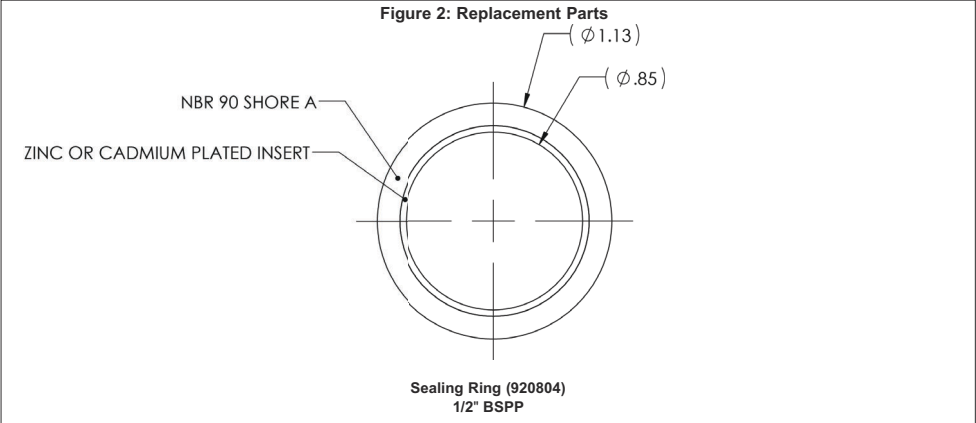



17.11 Manifold Pressure Relief (2901 PSI)

1. DESCRIPTION / FUNCTION

The Oxexo manifold pressure relief devices operate to ensure the safety of the Oxexo inert gas fire protection system. The pressure reliefs are installed in-line with the manifold before the pressure reducer to ensure that the pressure does not increase to a level that would rupture the system piping.

2. LISTINGS AND APPROVALS

 cULus Listed - EX5248 (Oxexo PR)

 FM Approved: Oxexo PR

3. TECHNICAL DATA

Specifications

Type: 1.1 C

Operating medium: Argon (IG-01), Nitrogen (IG-100)

Response pressure: 2901 psi (200 bar) at 122 °F (+50 °C)

Valve seat: metal seal

Thread: G1/2 ISO228 converted to 1/2" NPT

Orientation of device: Vertical



Designation	Part no.	Weight
Safety Valve 2901 psi	885136D	2.2 lbs (1.0 kg)

 **WARNING:** Cancer and Reproductive Harm-
www.P65Warnings.ca.gov

Figure 1: Dimensions
Inches (mm)

NOTE: This image represents an older model, limited in stock.

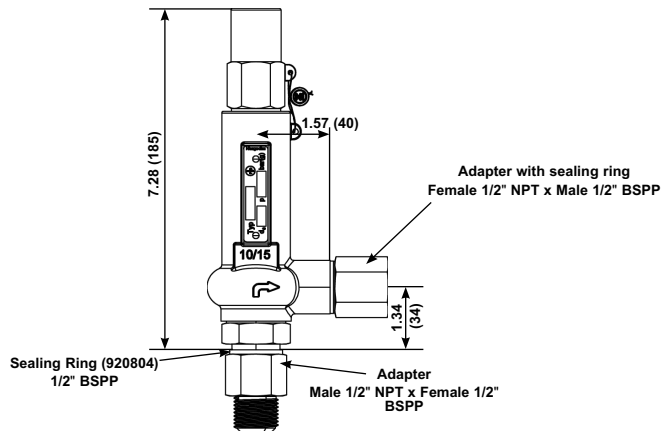
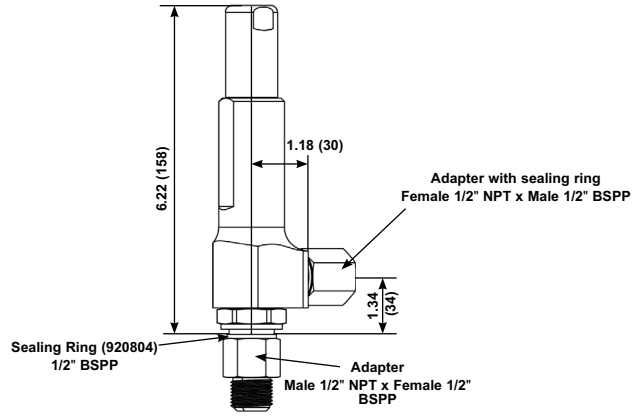
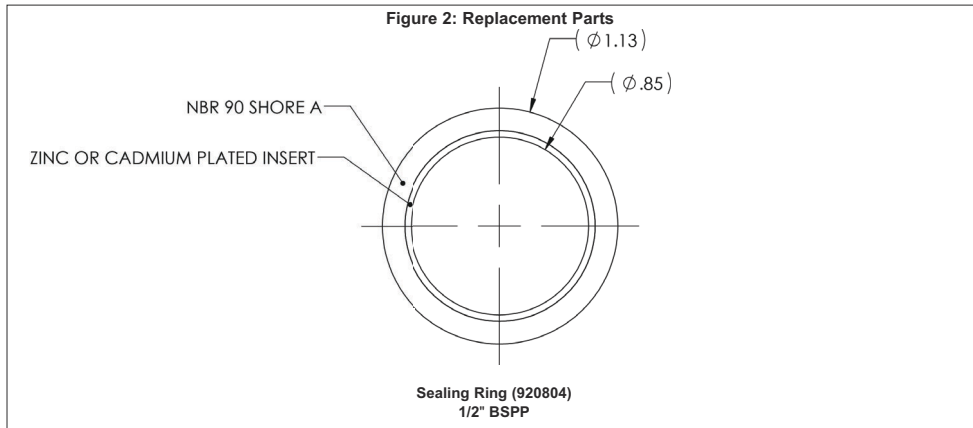

Figure 1: Dimensions
Inches (mm)

NOTE: This image represents the newer Viking model.







17.12 Manifold Pressure Relief (4351 psi)

1. DESCRIPTION / FUNCTION

The Oxexo manifold pressure relief devices operate to ensure the safety of the Oxexo inert gas fire protection system. The pressure reliefs are installed in-line with the manifold before the pressure reducer to ensure that the pressure does not increase to a level that would rupture the system piping.

2. LISTINGS AND APPROVALS

 cULus Listed - EX5248 (Oxexo PR)

 FM Approved: Oxexo PR

3. TECHNICAL DATA

Specifications

Type: 1.1 C

Operating medium: Argon (IG-01), Nitrogen (IG-100)

Response pressure: 4351 psi (300 bar) at 122 °F (+50 °C)

Valve seat: metal seal

Thread: G1/8 ISO228 converted to 1/2" NPT

Orientation of device: Vertical

Safety valve according to Pressure Equipment Directive 97/23/EC Category IV



Designation	Part no.	Weight
Safety Valve 4351 psi (300 bar)	886281D	3.1 lbs (1.4 kg)

 **WARNING:** Cancer and Reproductive Harm-
www.P65Warnings.ca.gov

Figure 1: Dimensions
Inches (mm)

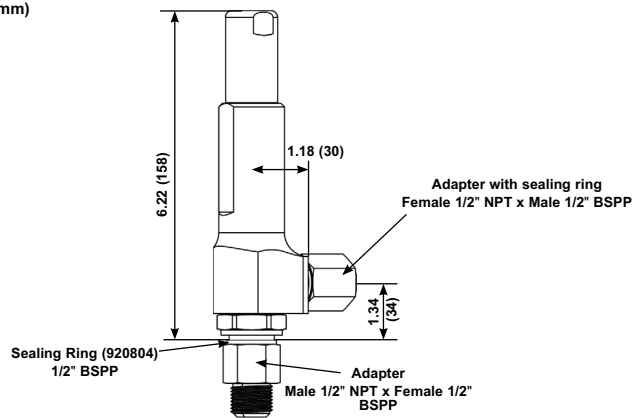

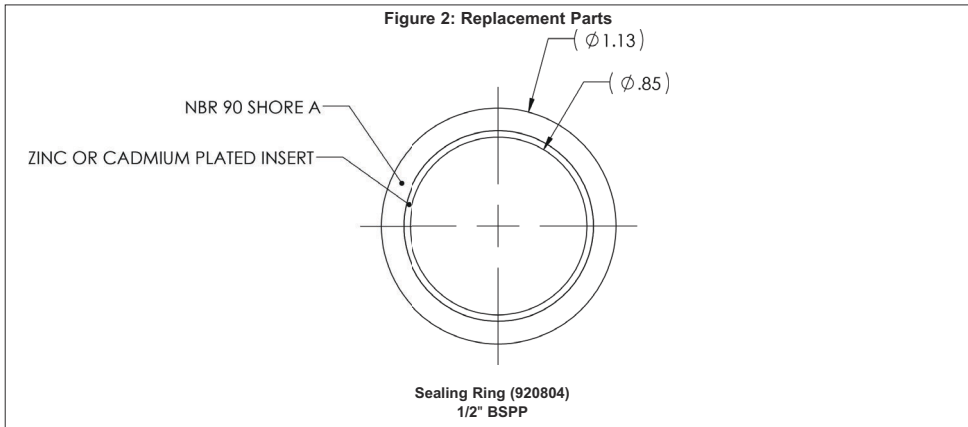

17.13 Pilot Line Pressure Relief

1. DESCRIPTION

The Oxexo pilot line pressure relief devices are used in accordance with project specific system designs in fixed fire extinguishing systems. The pressure relief devices (part numbers 24498 and 24499) release small amounts of leakage from pneumatic pilot lines and close automatically when subjected to higher pressures. The devices are intended only for releasing small amounts of pressure. Installation of the devices near any sources of potential leakage, for example a pilot gas tank, is recommended.

The manual release version (24499) includes an optional* release device that is used to manually vent pilot lines.

*24499 may be a required assembly component in certain jurisdictions. Refer to the Authority Having Jurisdiction for more information.

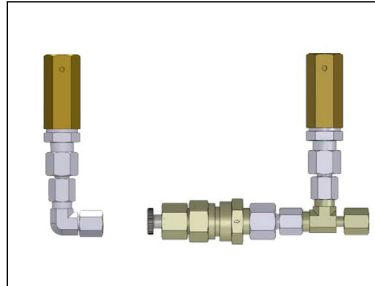

2. LISTINGS AND APPROVALS



cULus Listed - EX5248 (Oxexo PR CF)



FM Approved: Oxexo PR CF

3. TECHNICAL DATA

Specifications

Operating medium: Argon (IG-01) and Nitrogen (IG-100)

Working pressure: 5294 psi (365 bar)

Temperature range: -4 °F to 122 °F (-20 °C to +50 °C)

Connection DN4: 6 x 1 pipe

Device Orientation: vertical (see figure 2)

Material Standards

Housing: brass / steel

Gasket: NBR

Ball: Stainless steel

Connection components*:

- Adapter; female 6 mm drawn tubing (M12 x 1.5) x Female 6 mm drawn tubing (M14 x 1.5)
- Tee fitting; male 6 mm x female 6 mm x male 6 mm
- Tee fitting; male 6 mm x male 6 mm x female 6 mm

*All connection components comprised of zinc-plated steel

Designation	Part no.	Weight
Pilot Line Pressure Relief assembly	24498	0.303 lbs (0.14 kg)
Pilot Line Pressure Relief with Manual release	24499	0.759 lbs (0.34 kg)



WARNING: Cancer and Reproductive Harm-
www.P65Warnings.ca.gov

4. INSTALLATION

The Pilot Line Pressure Relief must be installed into the pilot lines in an upright position. The Oxexo system will be unable to pressurize or release any agent while the manual release device is being held open.

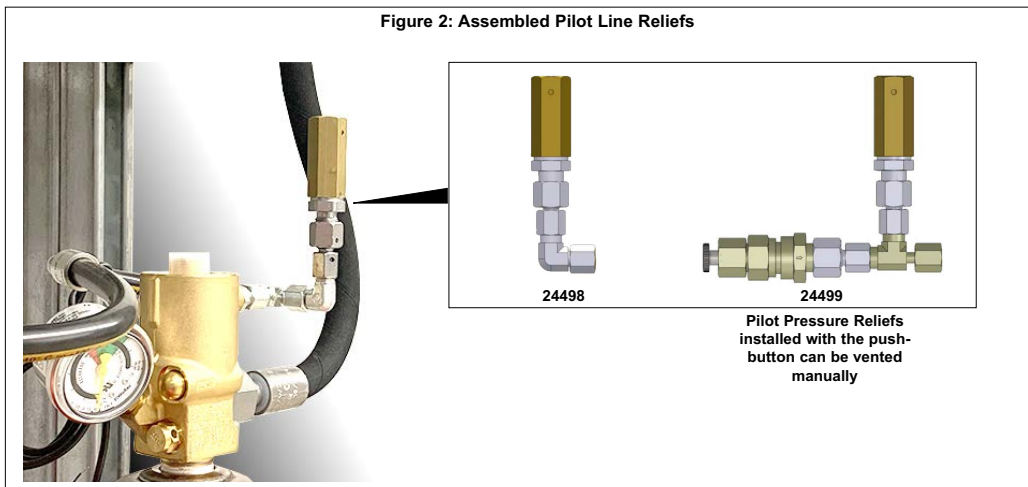
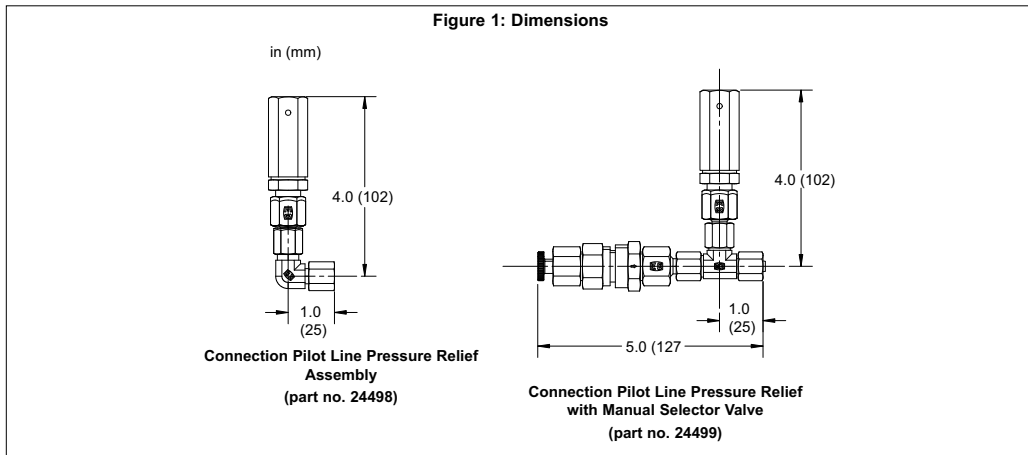

17.14 Pilot Line Lock-out Valve

1. DESCRIPTION

The pilot line lock-out valve prevents the release of the extinguishing agent to the extinguishing area by means of a manually operated lever. When the system can be activated unintentionally or people are unable to leave the extinguishing area within the egress time (i.e. for repair or maintenance work), the pilot line lock-out valve acts as a non-electrical blocking device that prevents the extinguishing agent from being released.

The limit switches attached to the pilot line lock-out valve are lab approved for field wiring. Limit switches are not available for separate purchase. The pilot line lock-out valve hardware comes fully assembled.

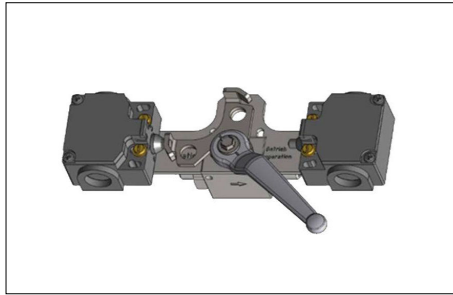

2. LISTINGS AND APPROVALS

 cULus Listed - EX5248 (Oxeo PR CF)

 FM Approved: Oxeo PR CF

 **WARNING:** Cancer and Reproductive Harm-
www.P65Warnings.ca.gov

Designation	Weight	Part no.
Pilot line lock-out device	1.8 lbs (0.8 kg)	878070D

3. TECHNICAL DATA

NOTE: The Pilot Line Lock-out Valve must be located after the pressure regulator (part no. 926811).

3.1 - Specifications and Ratings	
Parameter	Value
Operating medium	Argon
	Nitrogen
Working pressure	2030 psi (140 bar)
Nominal diameter	DN6
Connection threads	M12 x 1.5
Temperature range	-22 °F to 176 °F (-30 °C to +80 °C)
Connection	cone for 6 mm steel pipe

3.2 - Specifications and Ratings for Limit Switch (Part no. 930351)	
Parameter	Value
Type	PS226-Z11-S200; Actuator type B according to DIN EN 50047 (pressure bolt S200)
Housing	Glass-fiber reinforced thermoplastic, self-extinguishing
Switching System	Snap-action switching with positive break NC contact
Contacts	1 NC contact, 1 NO contact on each switch
Contact Material	Silver
Rated insulation voltage U_i	300 V
Rated impulse withstand voltage U_{imp}	4 kV
Continuous current I_{th}	10 A
Rated operating current/voltage I_e/U_e	3 A (240 VAC)
Positive opening force	min. 40 N
Mechanical Life	10 x 10 ⁶ operations
Actuating speed	Maximum 0.5 m/s; minimum 10 mm/min
Switching frequency	Maximum 5000/h
Protection class	IP66, IP67
Lateral cable routing	2 x 1/2" NPT - all conduit
Connection cross-section	Minimum 0.75 mm ² (including wire end ferrule) Maximum 2.5 mm ² (including wire end sleeve)

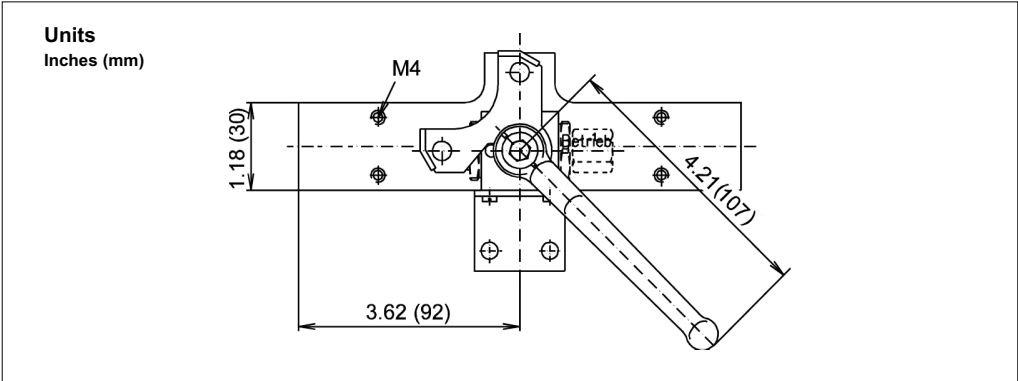

Figure 1: Dimensions

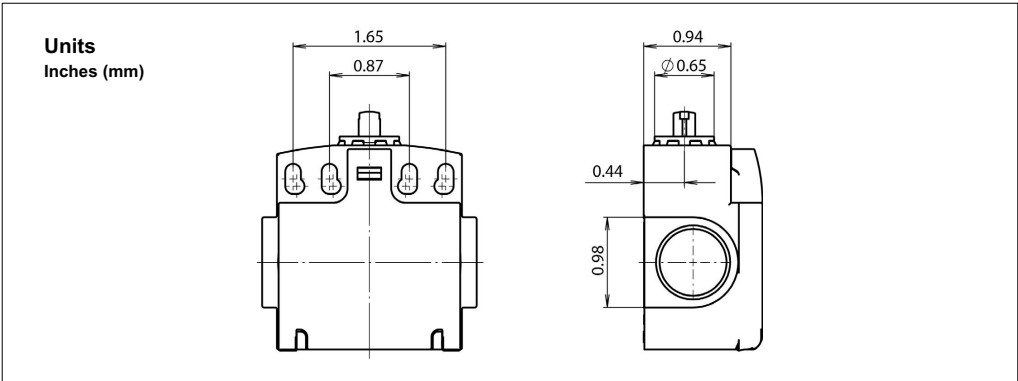

Figure 2: Limit Dimensions

17.15 Agent Supply Lock-Out Valves

1. DESCRIPTION

The Oxexo lock-out valve assembly is designed for use in inert gas fire extinguishing systems. The lock-out valve is used for flow control with electrical monitoring of the flow condition.

Flow states can be:

- Closed = no flow
- Opened = flow possible

The ball valve is opened or closed by turning the handle 90 degrees. The monitor component verifies whether the ball valve is fully closed or fully open. The switch plate is marked with "Closed" or "Open," and actuates the corresponding limit switch. The switch plate and holder are provided with holes to allow the ball valve to be locked in position by means of a U-lock. Flow direction is indicated by a marking on the side of the ball valve.

2. LISTINGS AND APPROVALS



cULus Listed - EX5248 (Oxexo PR CF)



FM Approved: Oxexo PR CF

Designation	Weight	Part no.
CF Lock-out valve assembly - 1"	31.1 lb (14.1 kg)	4005115D
CF Lock-out valve assembly - 1.5"	39.0 lb (17.7 kg)	4005116D
CF Lock-out valve assembly - 2"	57.5 lb (26.1 kg)	4005117D
CF Lock-out valve assembly - 2.5"	85.0 lb (38.6 kg)	4005082D
CF Lock-out valve assembly - 3"	92.6 lb (42.0 kg)	4005083D
CF Lock-out valve assembly - 4"	161.6 lb (73.3 kg)	4005084D
PR Lock-out valve assembly	70.6 lb (32 kg)	24768



WARNING: Cancer and Reproductive Harm-
www.P65Warnings.ca.gov

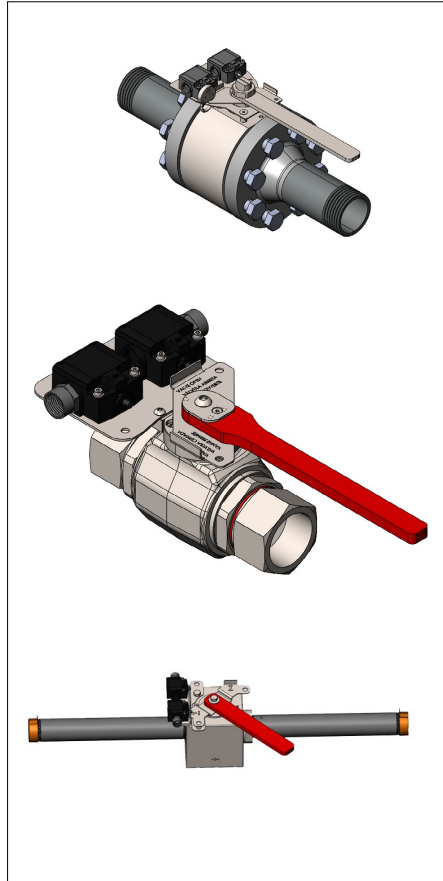

CAUTION

Heavy Object

May cause muscle stress or back injury. Use lifting aids and proper lifting technique when lifting or moving

3. TECHNICAL DATA

3.1 - Specifications and Ratings	
Parameter	Value
Operating medium	Argon
	Nitrogen
Working pressure	PR: 5294 psi (365 bar)
	CF: 2031 psi (140 bar)
Test pressure	PR: 7948 psi (548 bar)
	CF: 3045 psi (210 bar)
Temperature range	PR: -22 °F to 176 °F (-30 °C to +80 °C)
	CF: -4 °F to 131 °F (-20 °C to 55 °C)
Ball valve (body/spigot/cover) material	Steel
Pipe nipple material	Steel, galvanized
Limit switch (part no. 930351)	
Type	PS226-Z11-S200; Actuator type B according to DIN EN 50047 (pressure bolt S200)
Housing	Glass-fiber reinforced thermoplastic, self-extinguishing
Switching system	Snap-action switching with positive break NC contact
Contacts	1 NC contact, 1 NO contact on each switch
Contact material	Silver
Rated insulation voltage Ui	300 V
Rated impulse withstand voltage Uimp	4 kV
Continuous current Ith	10 A
Rated operating current/voltage Ie/Ui	3 A (240 VAC)
Positive opening force	min. 40 N
Mech. Life	10 x 10 ⁶ operations
Actuating speed	max. 0.5 m/s; min 10 mm/min
Switching frequency	max. 5000/h
Protection class	IP66, IP67
Lateral cable routing	2 x 1/2" NPT - all conduit
Connection cross-section	min. 0.75 mm ² (including wire end ferrule); max. 2.5 mm ² (including wire end sleeve)

17.16 Shuttle Non-Return Valve

1. DESCRIPTION

The shuttle non-return valve is used for the pneumatic directional control of pneumatic systems with two different pressure sources. The shuttle non-return valve is used in IG-01 and IG-100 fire extinguishing systems. The shuttle non-return valve kit comes with pilot line adapters included.

2. LISTINGS AND APPROVALS



cULus Listed - EX5248 (Oxeo PR CF)



FM Approved: Oxeo PR CF

3. TECHNICAL DATA

3.1 - Specifications and Ratings	
Parameter	Value
Operating medium	Argon
	Nitrogen
Working pressure	29 to 2030 psi (2 to 140 bar)
Test pressure	3045 psi (210 bar)
Rate of pressure rise	Minimum 43.5 psi/sec (minimum 3 bar/sec)
Installation position	Feedings only horizontal
Material standards	
Housing	Aluminum
Gasket	NBR
Ball	Stainless steel

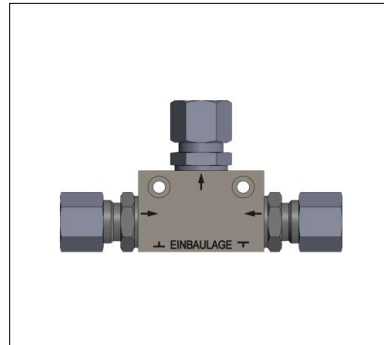

Designation	Part no.
Shuttle non-return valve	886247D

WARNING: Cancer and Reproductive Harm - www.P65Warnings.ca.gov

4. OPERATION

The operation of the shuttle non-return valve is triggered by the input of pneumatic pressure from one of two directions. Depending on the direction of the input pressure, the valve will operate in one of two ways:

When input "A" is pressurized, input "B" closes, creating a passage from input "A" to the output of the valve.

When input "B" is pressurized, input "A" closes, creating a passage from input "B" to the output of the valve.

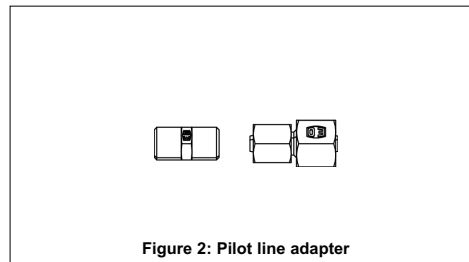
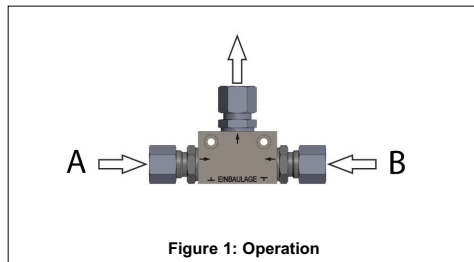

5. INSTALLATION

Prior to installation the release pipes shall be checked for cleanliness and blown through with compressed air if necessary. Refer to Figure 3 for approved installation positions.

NOTE: The Shuttle Non-Return Valve must be located after the pressure regulator (part no. 926811).

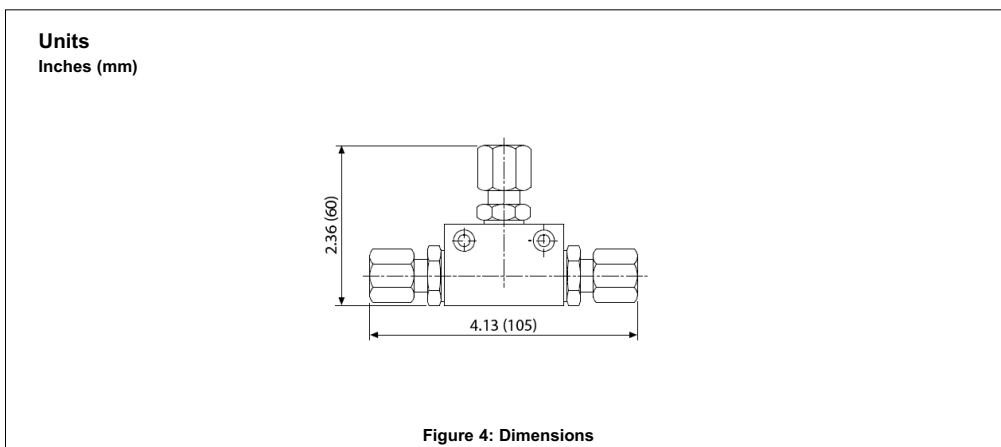
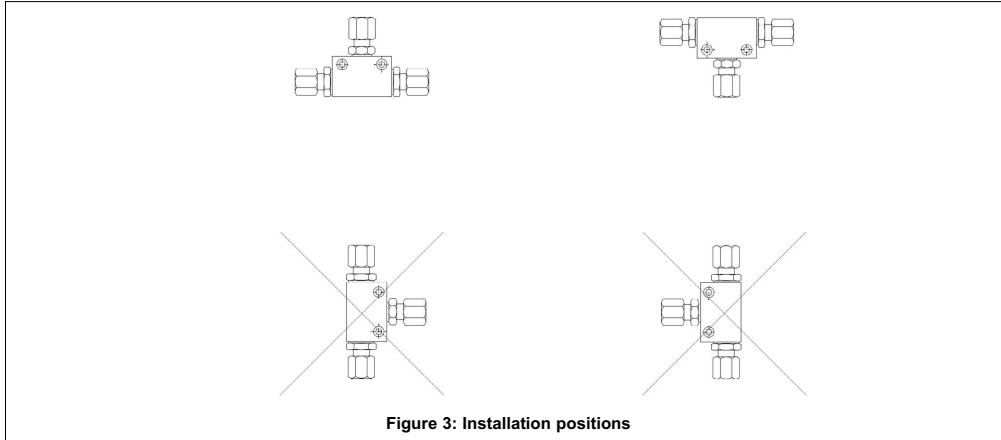

17.17 Pressure Reducer

1. DESCRIPTION

The pressure reducer 200 bar / 10 bar N₂ with pressure gauge on outlet-side is used in the Oxeo inert gas extinguishing system with ConstantFlow HD300-LCP for use with 200 bar nitrogen pilot control cylinders.

2. LISTINGS AND APPROVALS



cULus Listed - EX5248 (Oxeo PR CF)



FM Approved: Oxeo PR CF

3. TECHNICAL DATA

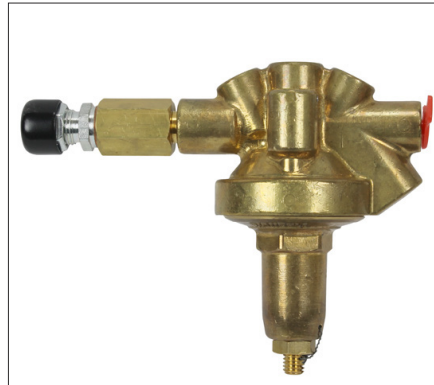

3.1 - Specifications and Ratings	
Parameter	Value
Extinguishing agent	Nitrogen (99.9% agent purity minimum)
Inlet pressure	Maximum 200 bar (2901 psi)
Outlet pressure	Permanently adjusted at 10.5 bar (152 psi)*
Temperature range	-4 °F to 122 °F (-20 °C to +50 °C)
Connection	
Inlet	Union according to ISO 8434-1, SWOSDS - L10 x G1/4A
Outlet	Plug in union straight G1/4 HEX, type IQSG1410G
Housing material	Brass

*Secured with hexagon nut and sealed with sealing wire.

Designation	Part no.	Weight
Pressure reducer 200 bar / 10 bar N ₂ u*	926811	3.53 lbs (1.6 kg)

* 'u' designates approved universal use in the Americas.

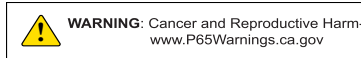

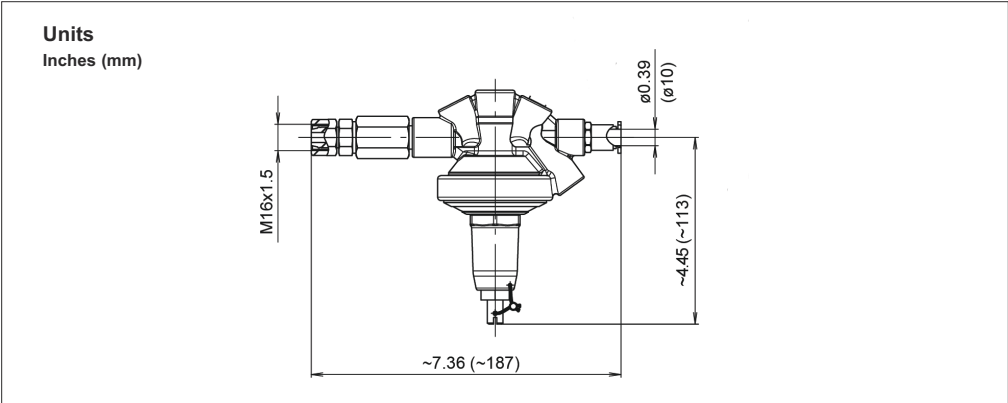



Figure 1: Dimensions

17.18 Pressure Gauges

1. DESCRIPTION / FUNCTION

The contact pressure gauge is installed in the agent tank valve. The gauge is available in either normally open (NO) or normally closed (NC) contacts. The contacts are activated by the decrease in tank pressure during a system discharge or loss of tank pressure due to a leak. Gauges are available for either 2901 psi (200 bar) or 4351 psi (300 bar) tanks.

2. LISTINGS AND APPROVALS

 cULus Listed - EX5248 (Oxeo PR CF)

 FM Approved: Oxeo PR CF

3. TECHNICAL DATA

Specifications

Pressure Medium: argon (IG-01), nitrogen (IG-100)
 Nominal size: 50 mm
 Accuracy class: 1.6
 Temperature rating: -4 °F to 131 °F (-20 °C to +55 °C)
 IP code: IP65 with mounted cable

Electrical Data

Switching voltage: 4.5 - 24 VDC / VAC
 Switching current: 5 - 100 mA
 Contact load: 2.4 W maximum, dry contact
 Conducting wire: two-core, 39.37" (100 cm)
 Cross-section of conducting wire: 0.000217 in² (0.14 mm²)

Material Standards

Housing: stainless steel
 Pointer: plastic, yellow
 Measuring network, motion work: copper alloy
 Inspection glass: polycarbonate
 Pressure connection: M12x1, SW14

Design of Instrument Dial

Dial design: according to UL2127
 Material: Aluminum, white
 Scale: dual scale (psi/bar)
 Indicating range: 0 - pressure range (see table below)

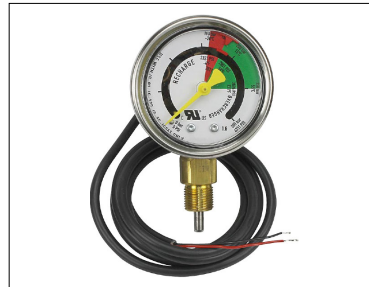

Designation	Part no.
Oxeo Contact Pressure Gauge	See table below

 **WARNING:** Cancer and Reproductive Harm - www.P65Warnings.ca.gov

Part No.	Nominal Pressure at 59 °F (15 °C) psi (bar)	Switching Mode ^{1, 2}	Pressure range / switching point psi (bar)	Tolerance switching point UL psi (bar)	Weight lbs (kg)
927612	2901 (200)	Break contact ¹ (NO) under pressure	4351 / 2611 (300 / 180)	± 108.8 (± 7.5)	0.33 (0.15)
927616	4351 (300)		6527 / 3916 (450 / 270)	± 163.2 (± 11.25)	0.33 (0.15)
927615	2901 (200)	Make contact ² (NC) under pressure	4351 / 2611 (300 / 180)	± 108.8 (± 7.5)	0.33 (0.15)
927617	4351 (300)		6527 / 3916 (450 / 270)	± 163.2 (± 11.25)	0.33 (0.15)

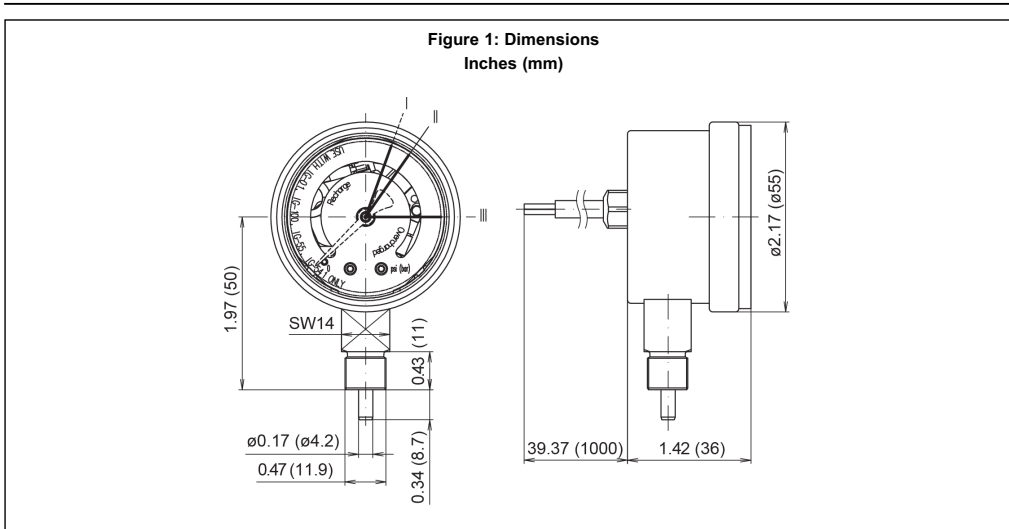

Indicating Range Marked

Nominal Pressure at 59 °F (15 °C) psi (bar)	Red area I to II bar	Green area II to III bar	Marking at nominal pressure psi (bar)	Marking at I psi (bar)	Marking at III psi (bar)
2901 (200)	160-180	180-200	2901 (200) 59 °F (15 °C)	2321 (160) at -4 °F (-20 °C)	3626 (250) at 131 °F (55 °C)
4351 (300)	235-270	270-366	4351 (300) 59 °F (15 °C)	2408 (235) at -4 °F (-20 °C)	5308 (366) at 131 °F (55 °C)

Figure 2: Contact Pressure Gauge Wiring

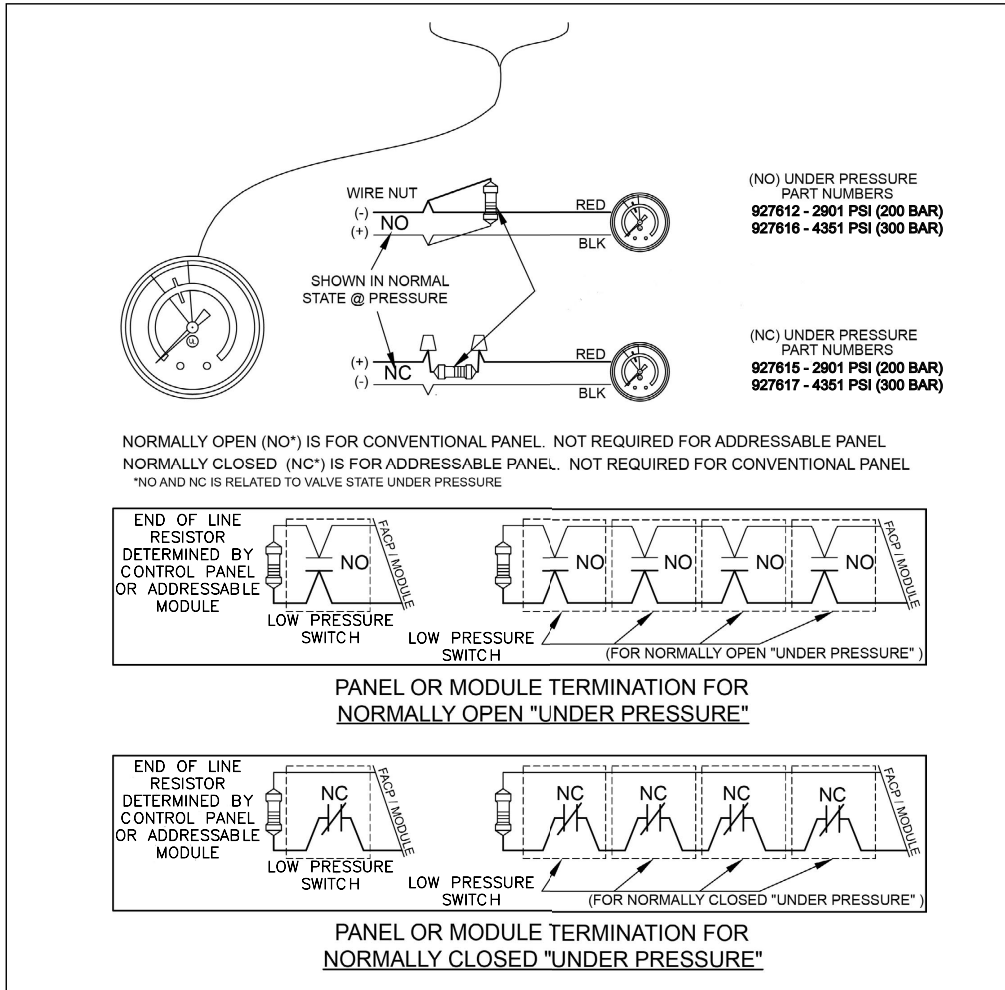

17.19 Releasing Solenoid

1. DESCRIPTION / FUNCTION



The release solenoid is used for the electrical actuation of a type QRV quick release valve. The solenoid is only suitable for usage inside buildings. By applying voltage to the solenoid, the force stored in a spring assembly is suddenly released. In this case, a plunger activates the pilot valve integrated into the quick release valve and vents the upper pressure chamber. This drop in pressure causes the extinguishing agent pressure to push the closing piston into an open position. This in turn causes the quick release valve to open.

The manual release device can also be fitted to the release solenoid as an additional means of release (sold separately). Only one extinguishing agent cylinder valve can be opened electrically by the application of the release device's nominal voltage. The release solenoid device is resettable using the reset tool (tool sold separately).



NOTE: The electrical actuation signal must be present for at least 5 seconds.

2. LISTINGS AND APPROVALS

cULus Listed - EX5248 (Oxeo PR CF)
 FM Approved: Oxeo PR CF

Designation	Part no.	Weight
Release solenoid	914027D	2.40 lbs (1.09 kg)
Reset Tool	934652	0.77 lbs (0.35 kg)

3. TECHNICAL DATA

Specifications

Operating voltage: 19 - 28 V DC
 Nominal voltage: 24 V DC
 Nominal current: 0.5 A maximum
 Duty cycle: 100% duty ratio
 Diagnostic current: 20 mA
 Tightening torque (valve): 18.44 ± 2.95 ft-lb (25 Nm ± 4)
 Temperature range:
 • per VdS and CE: -4 °F to 122 °F (-20 °C to 50 °C)
 • for transport and storage: -4 °F to 149 °F (-20 °C to 65 °C)
 Mounting thread: M20 x 1.5

Electrical connection

Connector plug: electrical connector 3 pole + ground (type GDME 3013) according to DIN EN 175301-803 Form A
 Maximum cable cross section: 0.023 in² (1.5 mm²)
 Electrical connection: PG13.5 with converter to 1/2" NPT
 Insulation material class as per FDE: Class F
 Protection class according to DIN 40050: IP65



Marking (see Figure 1)

Manufacturer date: YYYY/MM

Nominal voltage/nominal current: 24 VDC / 0.5 A

Torque: 25 Nm \pm 2

Part number: See table on previous page

Material Standards

Enclosure: Brass / nickel-plated steel

Seals: NBR (Acrylonitrile butadiene rubber)

Permanent magnet: Nd-Fe-B (neodymium iron boron)

Additional parts: steel, stainless steel, brass, copper, plastic

Terminal Assignment

- Terminal 1: Positive
- Terminal 2: Negative

Figure 1: Dimension Drawing
Inches (mm)

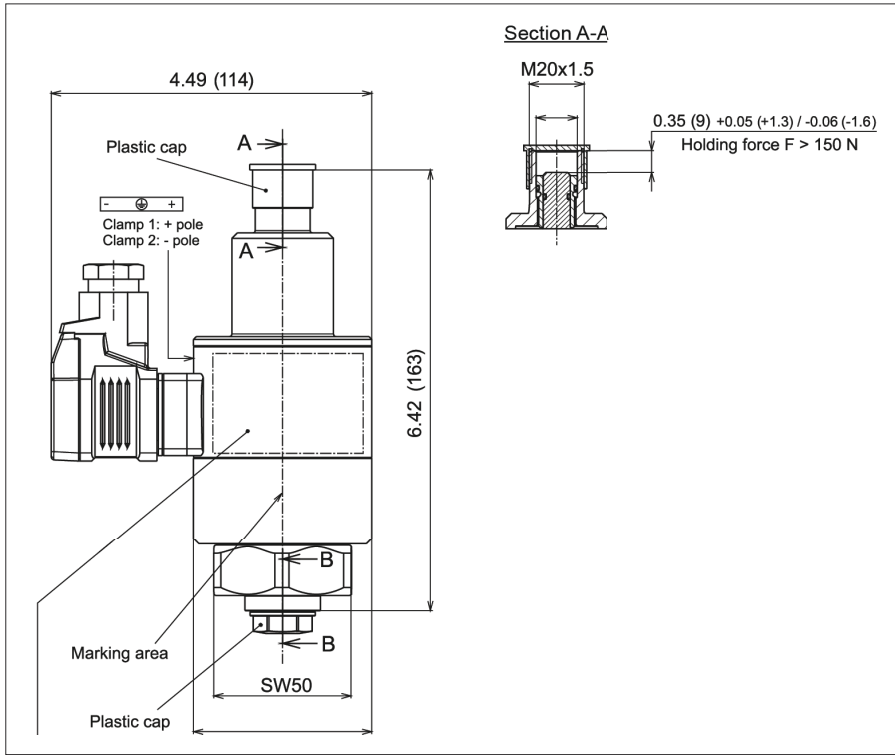

17.20 Reset Tool

1. DESCRIPTION / FUNCTION

The electric release device reset tool functions to reset the electrical actuator after the operation of the release. The reset tool is also to be used during any maintenance, routine or otherwise.

NOTE: There will be an audible "click" when the pin is properly reset into place. If the reset tool becomes too worn and there is no audible "click", the electrical actuator is not fully reset (see Figure 1 for accepted wear limit).

2. LISTINGS AND APPROVALS

Listings and Approvals are in the name of the manufacturer on a component basis. Refer to the manufacturer's documentation for more information.

3. TECHNICAL DATA

Marking

- Manufacturer Logo: Logo
- Part Number: 934652
- Manufacture date: YYYY-MM

Material Standards

- Lever with heat shrink tube: Brass/Rubber
- Screw connection: Brass
- Connecting bolt: Steel



Designation	Part no.	Weight
Reset Tool	934652	0.77 lbs (0.35 kg)

 **WARNING:** Cancer and Reproductive Harm-
www.P65Warnings.ca.gov

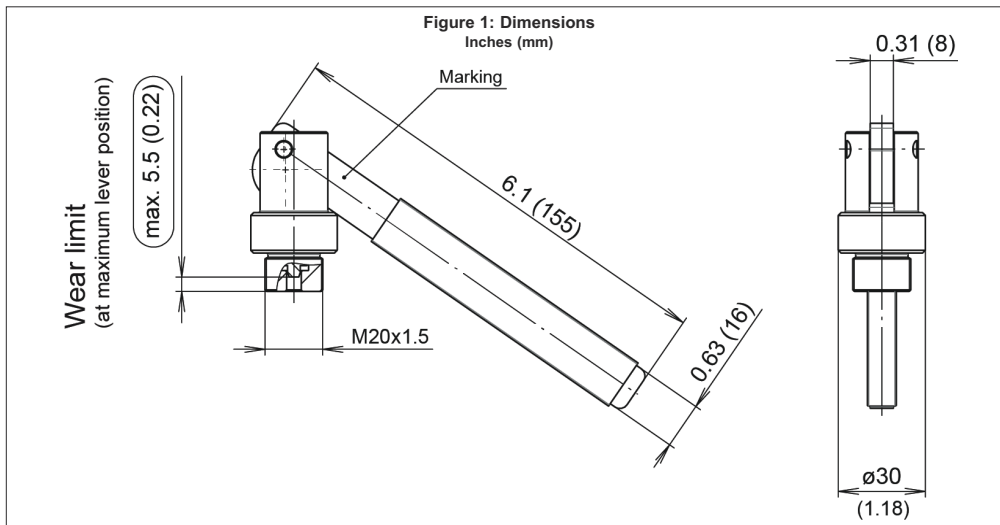

17.21 Release Solenoid Monitor Device

1. DESCRIPTION / FUNCTION

The release solenoid monitoring device makes it possible to monitor the electrical activation device on the valve. If the monitoring device is not properly installed, the limit switch sends a signal to the equipment room of the extinguishing system. As a result, an insufficient or incorrect assembly of the electrical activation device is signaled.

The monitoring device is exclusively used in argon (IG-01) and nitrogen (IG-100) fire extinguishing systems. The monitoring must only be used within the specified parameters and in accordance with the Authorities Having Jurisdiction.



2. LISTINGS AND APPROVALS



cULus Listed - EX5248 (Oxeo PR CF)



FM Approved: Oxeo PR CF

3. TECHNICAL DATA

Specifications

Limit switch type: PS226-Z11-R200

Housing: plastic, glass-fiber-reinforced

Protection class according to DIN 40050: IP66, IP67

according to IEC 60529

Contacts: 1 NC, 1 NO

Ambient temperature: -4 °F to 122 °F (-20 °C to +50 °C)

Switch system: Spring control, actuator type C to DIN EN 50047 (roller plunger R200)

Utilization category:

- AC-15: 240 VAC / 3 A
- DC-13: 24 VDC / 3 A

Dimensions (W x H x D): 3.93" x 4.72" x 3.54" (100 mm x 120 mm x 90 mm)

Tightening torque: 18.44 ± 2.95 ft-lb (25 ± 4 Nm)

Adapter included for 1/2" NPT conduit connections (all components come unassembled)

Designation	Part no.	Weight
Release solenoid monitor device	930865D	0.59 lbs (0.27 kg)



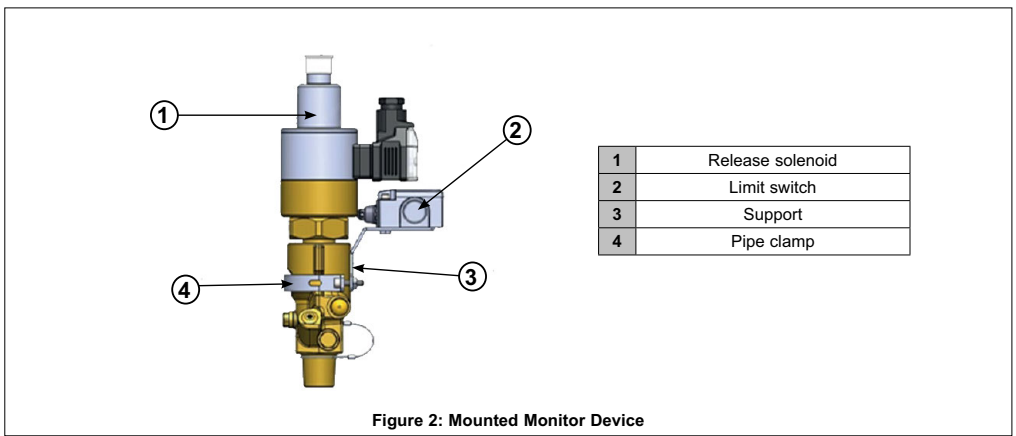
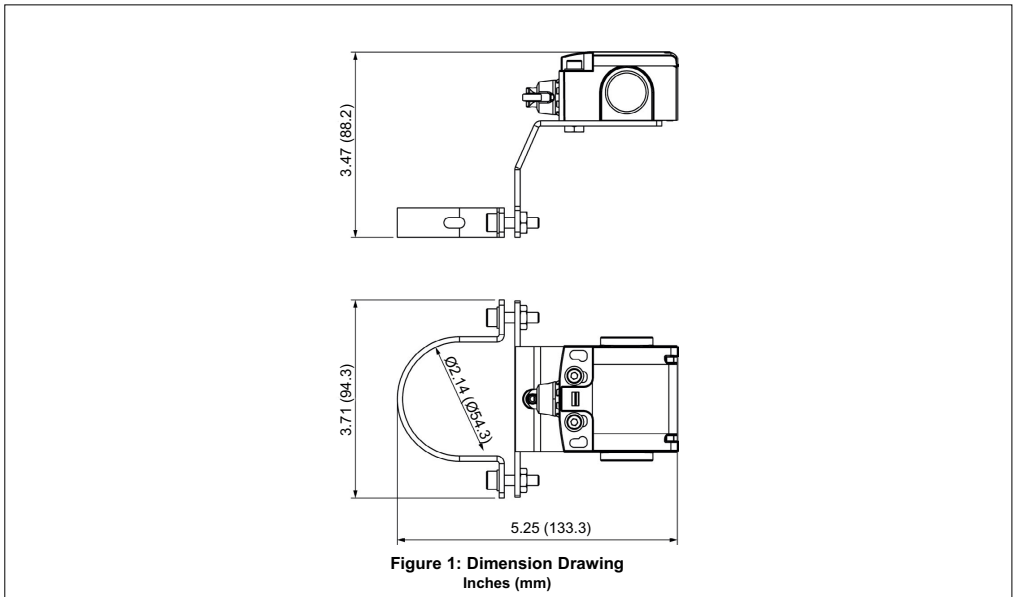

17.22 Manual Release Device

1. DESCRIPTION

The manual release device is used for the manual operation of quick release valves of type QRV. The operation takes place by pressing down the manual lever to the stop, thereby actuating the quick release valve QRV by means of the release pin. The safety pin must be removed prior to manual actuation.

The manual release device can also be fitted to the electrical QRV release device (part number 914027D) as an additional means of release.

NOTE: The manual actuation must take place for at least 5 seconds.

2. LISTINGS AND APPROVALS



cULus Listed - EX5248 (Oxeo PR CF)

FM Approved: Oxeo PR CF

3. TECHNICAL DATA

Specifications

Release force for manual actuation: less than 150 N

Temperature range:

- per VdS and CE: -4 °F to 122 °F (-20 °C to +50 °C)
- During transport and storage: -4 °F to 149 °F (-20 °C to +65 °C)

Tightening torque: 18.44 ±2.95 ft-lb (25 ±4 Nm)

Fastening thread: M20 x 1.5

Marking

Manufacture date: (yyyy-mm)

Viking part no.: 914028

Torque: 18.44 ±2.95 ft-lb (25 ±4 Nm)

Material Standards

Housing: Brass

Further Parts: Stainless steel, steel, brass, plastic



Designation	Part no.	Weight
Manual release device	914028	0.24 lbs (0.11 kg)



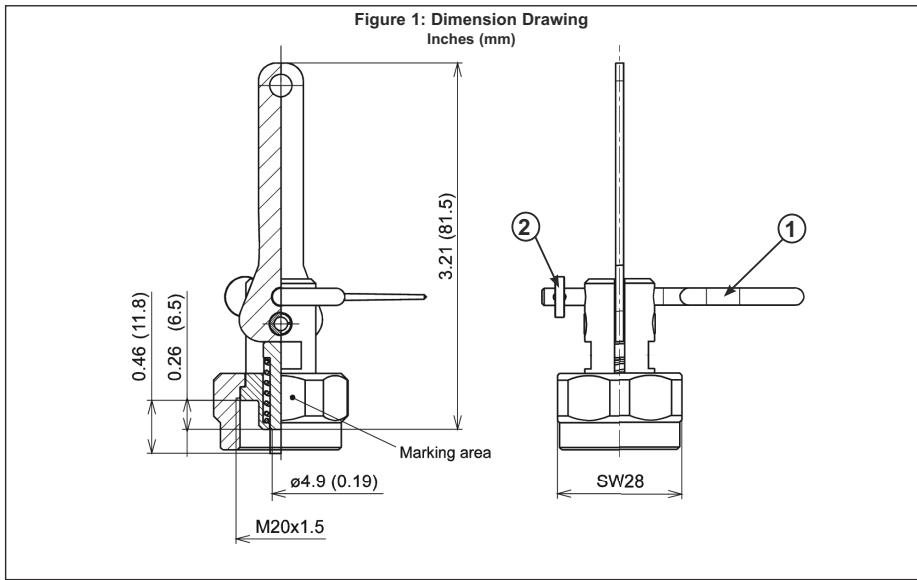

NOTE: Item 1 safety pin (PN 914033) and item 2 pin seal (PN 914034) can be purchased as replacement parts.

17.23 Warning Signs

1. DESCRIPTION

Viking Oxeo Fire Suppression Systems require warning signs to be attached to all access doors to identify the protected enclosure, warning of the existence of an Oxeo fire suppression system and associated components and the risks involved. Three types of signs are required (refer to Figures 1 through 3):

- Outside warning sign
- Inside warning sign
- Cylinder storage warning sign



2. LISTINGS AND APPROVALS

 cULus Listed - EX5248 (Oxeo PR CF)

 FM Approved: Oxeo PR CF

3. TECHNICAL DATA

Specifications

- Sign Types: Refer to Figures 1 through 3.
- Dimensions: 10" (254 mm) W x 10" (254 mm) H

Material Standards

Aluminum Plate

Ordering Information

Type	Part number	Language
Oxeo nitrogen Outside warning sign	24587	English
	24587-S	Spanish
	24587-F	French
Oxeo nitrogen Inside warning sign	24588	English
	24588-S	Spanish
	24588-F	French
Oxeo argon Outside warning sign	24589	English
	24589-S	Spanish
	24589-F	French
Oxeo argon Inside warning sign	24590	English
	24590-S	Spanish
	24590-F	French
Cylinder storage warning sign	26407	English
	26407-S	Spanish
	26407-F	French

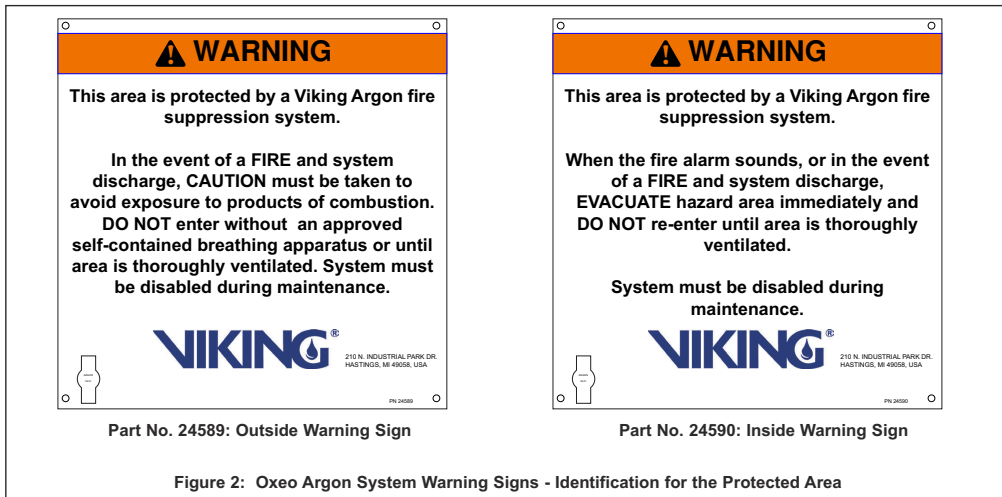
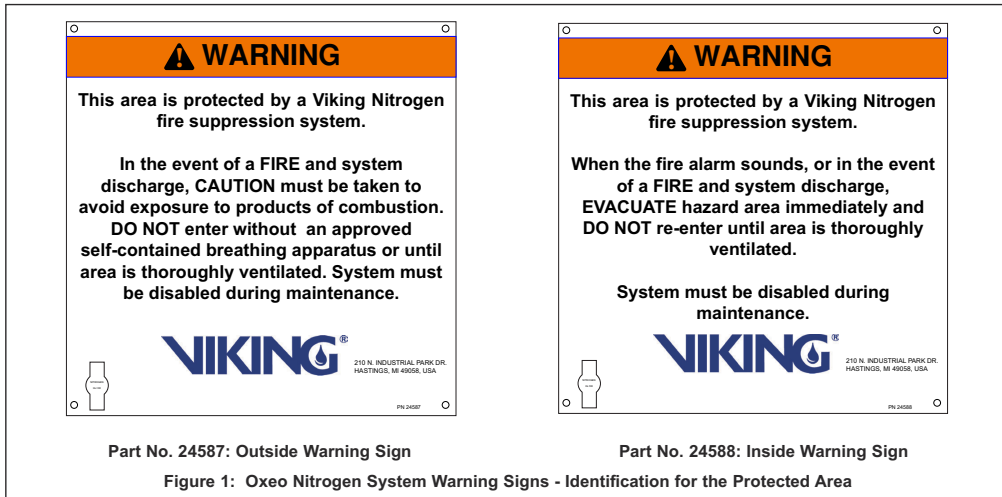

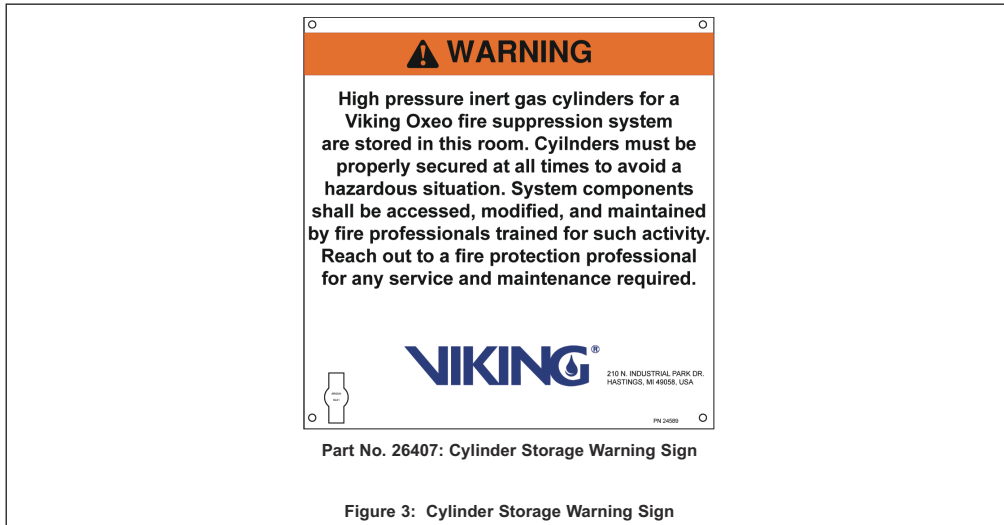

17.24 VN Nozzles

1. DESCRIPTION

The Viking Oxexo VN nozzles may only be used as room protection nozzles in Oxexo Fire Extinguishing Systems utilizing Argon (IG-01) or Nitrogen (IG-100). The Viking Oxexo VN nozzles are installed to distribute the extinguishing agent evenly in the extinguishing zone in the calculated flooding time. During activation, the extinguishing agent flows through the nozzle, expanding once it exits the nozzle bores.

The VN nozzle is comprised of a nozzle body and an orifice plate with a specifically calculated diameter. vInert must be used to determine the orifice diameter specific to the fire extinguishing system. VN nozzles are not permitted for use within corrosive environments.

2. LISTINGS AND APPROVALS



cULus Listed - EX5248 (Oxexo PR CF)



FM Approved: Oxexo PR CF

3. TECHNICAL DATA

Specifications

- Argon (IG-01) or Nitrogen (IG-100)
- Connecting thread: varies; refer to tables 2-11.
- Operational temperature range: -4 °F to 122 °F (-20 °C to +55 °C)
- Storage temperature range: -40 °F to 149 °F (-40 °C to +65 °C)
- Assembly torque: 29.5 ± 3.7 ft-lb (40 ± 5 Nm)

Material Standards

- Nozzle socket / nozzle head: brass
- Orifice: stainless steel

Ordering Information: Refer to tables 1-11.

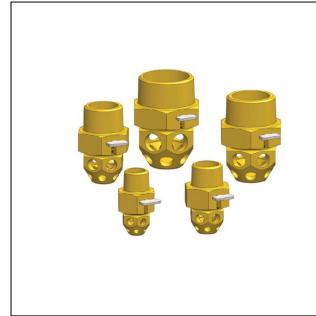

WARNING: Cancer and Reproductive Harm-
www.P65Warnings.ca.gov

4. INSTALLATION

1. Wrap the connection thread on the nozzle socket with a suitable sealant (e.g. PTFE tape).
2. Using a box wrench or a combination wrench on the width flat of the nozzle socket, firmly screw the nozzle into the fitting.
3. Using the correct hex socket wrench (refer to Table 1 for part numbers), tighten the nozzle to a torque of 45 ± 5 ft-lb (61 ± 7 Nm).

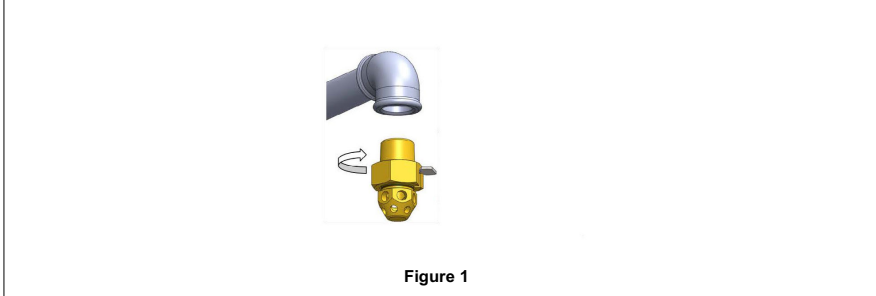

TABLE 1: WRENCH PART NUMBERS		
25099	Socket, 1/2" Drive, 22 mm	1/2" NPT Nozzles
25100	Socket, 1/2" Drive, 27 mm	3/4" NPT Nozzles
25101	Socket, 1/2" Drive, 32 mm	1" NPT Nozzles
25232	Socket, 3/4" Drive, 41 mm	1-1/4" NPT Nozzles
25233	Socket, 3/4" Drive, 46 mm	1-1/2" NPT Nozzles

5. MAINTENANCE

The following must be carried out as part of the extinguishing system’s maintenance intervals, either annually or upon system activation.

- Inspect the nozzles for any external damage, corrosion, contamination or any other visible marring. Check that all components are accounted for and that the nozzle has been installed properly.
- Immediately remove any debris from the nozzle bores. Dismount the nozzle to clean if necessary. Replace any damaged nozzles immediately.
- Spare nozzles should always be stored in their original packaging in dry conditions and protected against damage.

NOTICE

Risk of product damage.
Harsh cleaning agents can damage metals.

- Do not use cleaning agents that are harmful to metals.

Table 2: 1/2" NPT VN Nozzles - 180° Style			
Ordering Number	Nozzle Body	Orifice Diameter Inches (mm)	Orifice Plate Number*
934164D-0118	934164	0.118 (3.0)	918524
934164D-0122		0.122 (3.1)	918525
934164D-0126		0.126 (3.2)	918526
934164D-0134		0.134 (3.4)	918527
934164D-0142		0.142 (3.6)	918528
934164D-0150		0.150 (3.8)	918529
934164D-0157		0.157 (4.0)	918530
934164D-0165		0.165 (4.2)	918531
934164D-0173		0.173 (4.4)	918532
934164D-0181		0.181 (4.6)	918533
934164D-0189		0.189 (4.8)	918534
934164D-0197		0.197 (5.0)	918535
934164D-0209		0.209 (5.3)	918536
934164D-0220		0.220 (5.6)	918537
934164D-0232		0.232 (5.9)	918538
934164D-0244		0.244 (6.2)	918539
934164D-0256		0.256 (6.5)	918540
934164D-0268		0.268 (6.8)	918541
934164D-0283		0.283 (7.2)	918542
934164D-0299		0.299 (7.6)	918543
934164D-0315		0.315 (8.0)	918544
934164D-0331		0.331 (8.4)	918545
934164D-0346		0.346 (8.8)	918546
934164D-0362		0.362 (9.2)	918547
934164D-0378		0.378 (9.6)	918548
934164D-0394		0.394 (10.0)	918549
934164D-0413		0.413 (10.5)	918550
934164D-0433		0.433 (11.0)	918551
934164D-0453	0.453 (11.5)	918552	
934164D-0472	0.472 (12.0)	918553	
934164D-0492	0.492 (12.5)	918554	

*Orifice plates not sold separately.

Form No. F_110321 Rev 04 January 2024

Table 3: 1/2" NPT VN Nozzles - 360° Style			
Ordering Number	Nozzle Body	Orifice Diameter Inches (mm)	Orifice Plate Number*
918745D-0118	918745	0.118 (3.0)	918524
918745D-0122		0.122 (3.1)	918525
918745D-0126		0.126 (3.2)	918526
918745D-0134		0.134 (3.4)	918527
918745D-0142		0.142 (3.6)	918528
918745D-0150		0.150 (3.8)	918529
918745D-0157		0.157 (4.0)	918530
918745D-0165		0.165 (4.2)	918531
918745D-0173		0.173 (4.4)	918532
918745D-0181		0.181 (4.6)	918533
918745D-0189		0.189 (4.8)	918534
918745D-0197		0.197 (5.0)	918535
918745D-0209		0.209 (5.3)	918536
918745D-0220		0.220 (5.6)	918537
918745D-0232		0.232 (5.9)	918538
918745D-0244		0.244 (6.2)	918539
918745D-0256		0.256 (6.5)	918540
918745D-0268		0.268 (6.8)	918541
918745D-0283		0.283 (7.2)	918542
918745D-0299		0.299 (7.6)	918543
918745D-0315		0.315 (8.0)	918544
918745D-0331		0.331 (8.4)	918545
918745D-0346		0.346 (8.8)	918546
918745D-0362		0.362 (9.2)	918547
918745D-0378		0.378 (9.6)	918548
918745D-0394		0.394 (10.0)	918549
918745D-0413		0.413 (10.5)	918550
918745D-0433		0.433 (11.0)	918551
918745D-0453		0.453 (11.5)	918552
918745D-0472		0.472 (12.0)	918553
918745D-0492	0.492 (12.5)	918554	

*Orifice plates not sold separately.

Table 4: 3/4" NPT VN Nozzles - 180° Style			
Ordering Number	Nozzle Body	Orifice Diameter Inches (mm)	Orifice Plate Number*
934165D-0413	934165	0.413 (10.5)	918567
934165D-0433		0.433 (11.0)	918555
934165D-0453		0.453 (11.5)	918556
934165D-0472		0.472 (12.0)	918557
934165D-0492		0.492 (12.5)	918558
934165D-0512		0.512 (13.0)	918559
934165D-0531		0.531 (13.5)	918560
934165D-0551		0.551 (14.0)	918561
934165D-0571		0.571 (14.5)	918562
934165D-0591		0.591 (15.0)	918563
934165D-0610		0.610 (15.5)	918564
934165D-0630		0.630 (16.0)	918565
934165D-0650		0.650 (16.5)	918568
934165D-0669		0.669 (17.0)	916566

*Orifice plates not sold separately.

Table 5: 3/4" NPT VN Nozzles - 360° Style			
Ordering Number	Nozzle Body	Orifice Diameter Inches (mm)	Orifice Plate Number*
918746D-0413	918746	0.413 (10.5)	918567
918746D-0433		0.433 (11.0)	918555
918746D-0453		0.453 (11.5)	918556
918746D-0472		0.472 (12.0)	918557
918746D-0492		0.492 (12.5)	918558
918746D-0512		0.512 (13.0)	918559
918746D-0531		0.531 (13.5)	918560
918746D-0551		0.551 (14.0)	918561
918746D-0571		0.571 (14.5)	918562
918746D-0591		0.591 (15.0)	918563
918746D-0610		0.610 (15.5)	918564
918746D-0630		0.630 (16.0)	918565
918746D-0650		0.650 (16.5)	918568
918746D-0669		0.669 (17.0)	916566

*Orifice plates not sold separately.

Table 6: 1" NPT VN Nozzles - 180° Style			
Ordering Number	Nozzle Body	Orifice Diameter Inches (mm)	Orifice Plate Number*
934166D-0591	934166	0.591 (15.0)	918570
934166D-0610		0.610 (15.5)	918571
934166D-0630		0.630 (16.0)	918572
934166D-0650		0.650 (16.5)	918569
934166D-0669		0.669 (17.0)	918573
934166D-0689		0.689 (17.5)	918578
934166D-0709		0.709 (18.0)	918574
934166D-0748		0.748 (19.0)	918575
934166D-0787		0.787 (20.0)	918576
934166D-0827		0.827 (21.0)	918577

*Orifice plates not sold separately.

Table 7: 1" NPT VN Nozzles - 360° Style			
Ordering Number	Nozzle Body	Orifice Diameter Inches (mm)	Orifice Plate Number*
918747D-0591	918747	0.591 (15.0)	918570
918747D-0610		0.610 (15.5)	918571
918747D-0630		0.630 (16.0)	918572
918747D-0650		0.650 (16.5)	918569
918747D-0669		0.669 (17.0)	918573
918747D-0689		0.689 (17.5)	918578
918747D-0709		0.709 (18.0)	918574
918747D-0748		0.748 (19.0)	918575
918747D-0787		0.787 (20.0)	918576
918747D-0827		0.827 (21.0)	918577

*Orifice plates not sold separately.

Table 8: 1-1/4" NPT VN Nozzles - 180° Style			
Ordering Number	Nozzle Body	Orifice Diameter Inches (mm)	Orifice Plate Number*
934167D-0709	934167	0.709 (18.0)	918579
934167D-0748		0.748 (19.0)	918580
934167D-0787		0.787 (20.0)	918581
934167D-0827		0.827 (21.0)	918582
934167D-0866		0.866 (22.0)	918583
934167D-0906		0.906 (23.0)	918584
934167D-0945		0.945 (24.0)	918585
934167D-0984		0.984 (25.0)	918586
934167D-1024		1.024 (26.0)	918587
934167D-1063		1.063 (27.0)	918588

*Orifice plates not sold separately.

Table 9: 1-1/4" NPT VN Nozzles - 360° Style			
Ordering Number	Nozzle Body	Orifice Diameter Inches (mm)	Orifice Plate Number*
918748D-0709	918748	0.709 (18.0)	918579
918748D-0748		0.748 (19.0)	918580
918748D-0787		0.787 (20.0)	918581
918748D-0827		0.827 (21.0)	918582
918748D-0866		0.866 (22.0)	918583
918748D-0906		0.906 (23.0)	918584
918748D-0945		0.945 (24.0)	918585
918748D-0984		0.984 (25.0)	918586
918748D-1024		1.024 (26.0)	918587
918748D-1063		1.063 (27.0)	918588

*Orifice plates not sold separately.

Table 10: 1-1/2" NPT VN Nozzles - 180° Style			
Ordering Number	Nozzle Body	Orifice Diameter Inches (mm)	Orifice Plate Number*
934168D-0945	934168	0.945 (24.0)	918594
934168D-0984		0.984 (25.0)	918595
934168D-1024		1.024 (26.0)	918596
934168D-1063		1.063 (27.0)	918597
934168D-1102		1.102 (28.0)	918598
934168D-1142		1.142 (29.0)	918599
934168D-1181		1.181 (30.0)	918600
934168D-1220		1.220 (31.0)	918601
934168D-1260		1.260 (32.0)	918602
934168D-1299		1.299 (33.0)	918603

*Orifice plate not sold separately.

Table 11: 1-1/2" NPT VN Nozzles - 360° Style			
Ordering Number	Nozzle Body	Orifice Diameter Inches (mm)	Orifice Plate Number*
918749D-0945	918749	0.945 (24.0)	918594
918749D-0984		0.984 (25.0)	918595
918749D-1024		1.024 (26.0)	918596
918749D-1063		1.063 (27.0)	918597
918749D-1102		1.102 (28.0)	918598
918749D-1142		1.142 (29.0)	918599
918749D-1181		1.181 (30.0)	918600
918749D-1220		1.220 (31.0)	918601
918749D-1260		1.260 (32.0)	918602
918749D-1299		1.299 (33.0)	918603

*Orifice plate not sold separately.

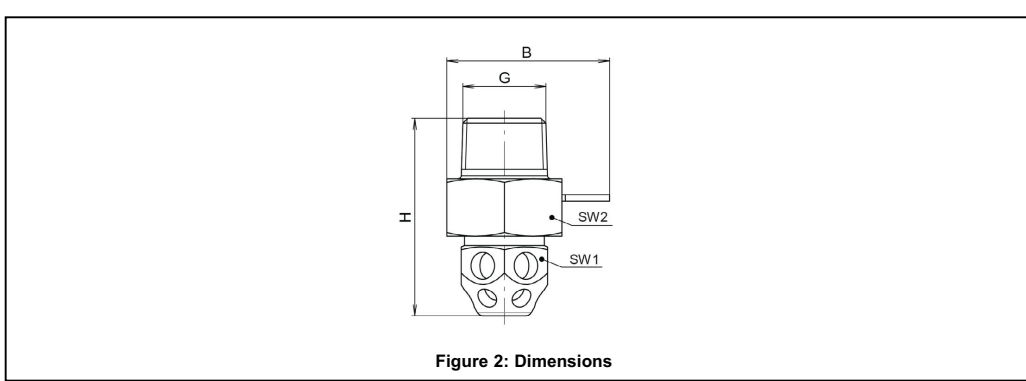

Figure 2: Dimensions

Table 13: Dimensions Inches (mm)				
G	H (approx.)	B (approx.)	SW1	SW2
1/2" NPT	2.32 (59)	1.77 (45)	0.87 (22)	1.18 (30)
3/4" NPT	2.48 (63)	2.0 (51)	1.06 (27)	1.41 (36)
1" NPT	2.76 (70)	2.20 (56)	1.26 (32)	1.61 (41)
1-1/4" NPT	3.07 (78)	2.52 (64)	1.61 (41)	1.97 (50)
1-1/2" NPT	3.27 (83)	3.07 (78)	1.81 (46)	2.16 (55)

CLASS B FUEL MDC VALUES- VN NOZZLES					
FUEL	VN NOZZLE	VN NOZZLE SHORT THROW	VN NOZZLE LONG THROW	CONSTANT FLOW	
	IG-100	IG-01	IG-01	IG-100	IG-01
Acetone	42.4	57.9	64.8	43.0	56.2
Acetonitrile	42.4	57.9	64.8	43.0	56.2
Aviation gas	42.4	57.9	64.8	43.0	56.2
Benzene	42.4	57.9	64.8	43.0	56.2
Diesel no. 2	42.9	58.6	65.6	43.6	56.8
Ethane	42.9	58.6	65.6	43.6	56.8
Ethyl acetate	43.6	59.5	66.6	44.2	57.7
Ethyl alcohol	51.9	70.9	79.4	52.7	68.8
Ethylene glycol	48.6	66.5	74.4	49.4	64.5
Gasoline - no lead	44.2	60.3	67.5	44.9	58.5
Heptane, commercial	42.4	57.9	64.8	43.0	56.2
i-Octane	42.4	57.9	64.8	43.0	56.2
i-Propyl alcohol	48.0	65.5	73.4	48.7	63.6
Kerosene	44.2	60.3	67.5	44.9	58.5
Lube oil at 500 °F	45.5	62.0	69.5	46.2	60.2
Methane	42.4	57.9	64.8	43.0	56.2
Methyl alcohol	62.1	84.8	95.0	63.1	82.3
Methyl isobutyl ketone	44.9	61.2	68.6	45.5	59.4
Morpholine	50.6	69.1	77.4	51.3	67.1
n-Butane	42.4	57.9	64.8	43.0	56.2
n-Heptane	42.4	57.9	64.8	43.0	56.2
n-Hexane	42.9	58.6	65.6	43.6	56.8
n-Octane	43.6	59.5	66.6	44.2	57.7
n-Pentane	42.4	57.9	64.8	43.0	56.2
n-Propyl alcohol	49.3	67.3	75.3	50.0	65.3
Propane	42.9	58.6	65.6	43.6	56.8
Tetrahydrofuran	47.3	64.7	72.5	48.0	62.8
Toluene	42.4	57.9	64.8	43.0	56.2
Transformer oil	44.9	61.2	68.6	45.5	59.4
Xylene	42.4	57.9	64.8	43.0	56.2

17.25 DCM Nozzle

1. DESCRIPTION

The Viking Oxexo DCM nozzle may only be used as room protection nozzles in Oxexo PR Fire Extinguishing Systems utilizing Argon (IG-01) or Nitrogen (IG-100). The Viking Oxexo DCM nozzles are installed to distribute the extinguishing agent evenly in the extinguishing zone in the calculated flooding time. The nozzle is provided with threads on the inlet and outlet side to enable mounting of the nozzle from the outside, for example, in bag houses, dust collectors and machining centers.

2. LISTINGS AND APPROVALS



cULus Listed - EX5248 (Oxexo PR)



FM Approved: Oxexo PR

*Listed as a component of an Oxexo PR Fire Extinguishing System

3. TECHNICAL DATA

Specifications

- Argon (IG-01) or Nitrogen (IG-100)
- Connecting Thread: 1/2" NPT or 3/4" NPT
- Temperature Range: -4 °F to 122 °F
- Minimum Nozzle Pressure:
 - Argon: 448.0 PSI
 - Nitrogen: 367.4 PSI

Material Standards

- Body: Stainless Steel, UNS-S31600

Accessories

Required:

Dust Protection Seal, 1/2" NPT or 3/4" NPT, **FM Approved only**

- **Material:** Aluminum Foil

Optional:

Flange, 1/2" NPT or 3/4" NPT (**Not part of nozzle approval**)

- **Material:** Stainless Steel, 302, Class 150 Fitting

Ordering Information: Refer to Table 1.

4. INSTALLATION

The nozzle must be located 1' from the top of the enclosure in order to achieve proper distribution of agent. The DCM nozzle is provided in either 1/2" NPT or 3/4" NPT thread on the inlet and outlet. With proper installation material, the nozzle can be mounted from the outside in bag houses, dust collectors and machining centers. To prevent obstructions to the nozzle orifice, the foil gasket must be used. The nozzle must be installed in the calculation area and should never be directly over sensitive equipment or devices. Modifications to the DCM nozzles are not allowed.

5. MAINTENANCE

At least once a year, service and maintenance must be performed on the nozzle to ensure its operation.

1. Nozzles must be removed from the piping and the orifice of the nozzle be cleaned of any debris that may have accumulated. This is done by carefully blowing compressed air into the nozzle. Once this is completed, the nozzles may be re-installed.
2. If there are any nozzles that have been damaged, they must be replaced. They cannot be repaired or reconditioned and re-installed.
3. Spare nozzles should always be stored in their original packaging in dry conditions and protected against damage.



WARNING: Cancer and Reproductive Harm-
www.P65Warnings.ca.gov

TABLE 1: ORDERING INFORMATION					
1) SELECT ORIFICE DIAMETER AND THEN 2) SELECT PART NUMBER TO THE LEFT OF ORIFICE DIAMETER					
1/2" DCM Nozzle				3/4" DCM Nozzle	
Part Number ¹	Orifice Dia. (inch)	Part Number ¹	Orifice Dia.(inch)	Part Number ¹	Orifice Dia. (inch)
23379-0118	.118	23379-0256	.256	24245-0413	.413
23379-0122	.122	23379-0268	.268	24245-0433	.433
23379-0126	.126	23379-0283	.283	24245-0453	.453
23379-0134	.134	23379-0299	.299	24245-0472	.472
23379-0142	.142	23379-0315	.315	24245-0492	.492
23379-0150	.150	23379-0331	.331	24245-0512	.512
23379-0157	.157	23379-0346	.346	24245-0531	.531
23379-0165	.165	23379-0362	.362	24245-0551	.551
23379-0173	.173	23379-0378	.378	24245-0571	.571
23379-0181	.181	23379-0394	.394	24245-0591	.591
23379-0189	.189	23379-0413	.413	24245-0610	.610
23379-0197	.197	23379-0433	.433	24245-0630	.630
23379-0209	.209	23379-0453	.453	24245-0650	.650
23379-0220	.220	23379-0472	.472	24245-0669	.669
23379-0232	.232	23379-0492	.492		
23379-0244	.244				
Accessories					
Dust Protection Seal, 1/2": Part Number 24454					
Dust Protection Seal, 3/4": Part Number 24455					
Flange, 1/2" NPT: Part Number 24459 (Optional)					
Flange, 3/4" NPT: Part Number 24460 (Optional)					
Footnote					
¹ In Design Manager, the "-" will not appear in the part number.					

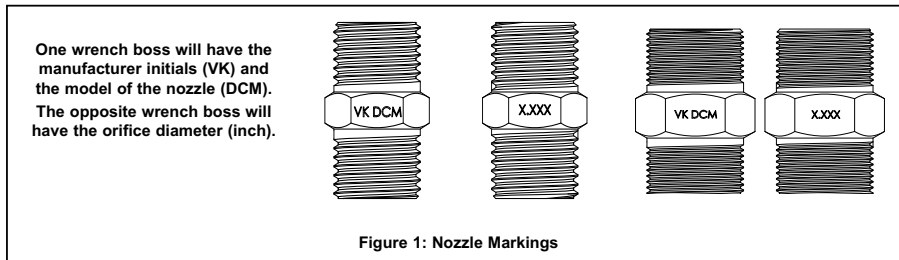

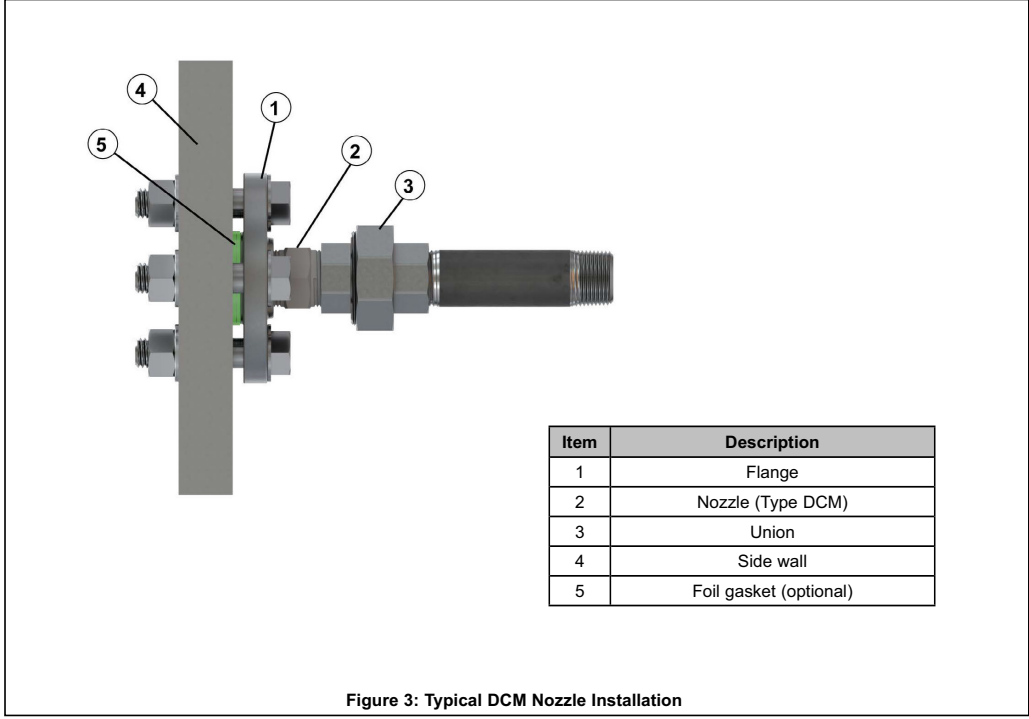
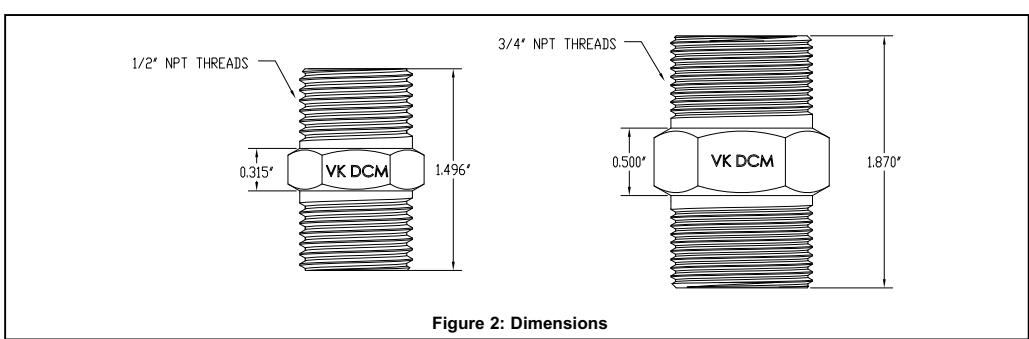

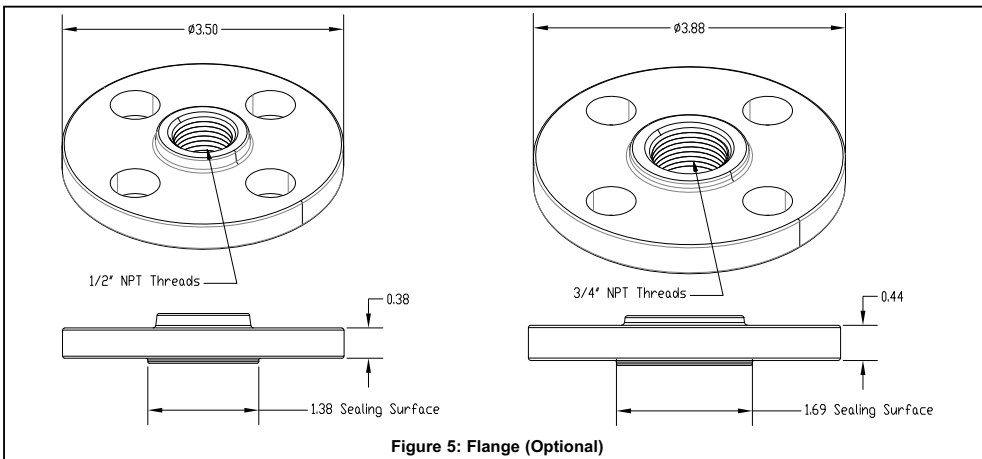
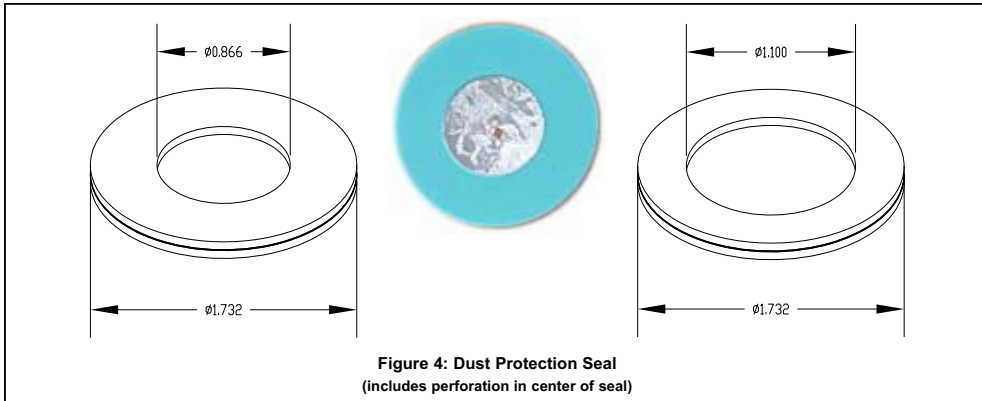

CLASS B FUEL MDC VALUES - DCM NOZZLES		
FUEL	IG-100	IG-01
Acetone	48.9	56.2
Acetonitrile	48.9	56.2
Aviation Gas	48.9	56.2
Benzene	48.9	56.2
Diesel No. 2	49.5	56.8
Ethane	49.5	56.8
Ethyl acetate	50.3	57.7
Ethyl alcohol	59.9	68.8
Ethylene glycol	56.1	64.5
Gasoline-NoLead	51	58.5
Heptane, commercial	48.9	56.2
i-Octane	48.9	56.2
i-Propyl alcohol	55.4	63.6
Kerosene	51.0	58.5
Lube Oil @500F	52.5	60.2
Methane	48.9	56.2
Methyl alcohol	71.7	82.3
Methyl isobutyl ketone	51.8	59.4
Morpholine	58.4	67.1
n-Butane	48.9	56.2
n-Heptane	48.9	56.2
n-Hexane	49.5	56.8
n-Octane	50.3	57.7
n-Pentane	48.9	56.2
n-Propyl alcohol	56.9	65.3
Propane	49.5	56.8
Tetrahydrofuran	54.6	62.8
Toluene	48.9	56.2
Transformer Oil	51.8	59.4
Xylene	48.9	56.2

17.26 Occupiable Space Kit

1. DESCRIPTION

The Oxexo occupiable space protection kit is used for situations where the egress time and concentration levels are exceeded as specified by NFPA 2001. The kit is comprised of several pneumatic safety devices, including the following:

- Oxexo pressure regulator/reducer
- Pneumatic horn (makrofon), NPT kit
- Oxexo pneumatic time delay, 145 psi
- Pilot hoses / adapters for straight pipe*
- Assorted adapters and fittings

*Straight pipe sold separately.

The Oxexo occupiable space protection kit connects the pilot cylinder to the first agent cylinder. The occupiable space kit does not include lock out valves or pilot cylinders.

NOTE: All pneumatic controls must be tested with shop air pressure prior to system commissioning. Use the pneumatic test kit (Figure 2) to convert the pilot lines to 1/4" NPT.

2. LISTINGS AND APPROVALS



cULus Listed - EX5248 (Oxexo PR CF)



FM Approved: Oxexo PR CF



Designation	Part no.
Occupiable space protection kit	25128
Pneumatic test kit	25761



WARNING: Cancer and Reproductive Harm-
www.P65Warnings.ca.gov

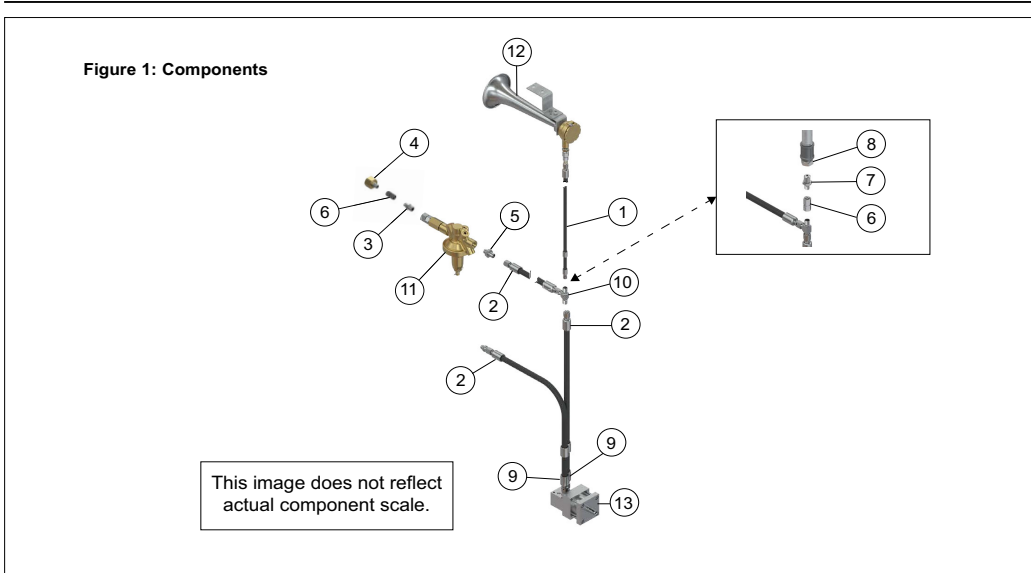

Item	Part Number	Designation	No. Req.
1	24469	Pilot hose, high pressure, 59" length	1
2	24467	Pilot hose, high pressure, 20" length	3
3	N/A	Adapter, M10mm (M16) x M 6mm (M12)	1
4	N/A	Adapter, F W21.8 x M 6mm (M12)	1
5	N/A	Adapter, M 1/4" BSPP x M 6mm (M12)	1
6	N/A	Adapter, F 6mm (M12) x 1/4" NPT	2
7	N/A	Adapter, Male 6mm (M12) x 1/4" NPT	1
8	N/A	Adapter, F 1/4" NPT x M 1/2" NPT	1
9	N/A	Adapter, M G1/8 x F M12x1.5	3
10	N/A	Tee, M 6mm x M 6mm x M 6mm (3 x M12)	1
11	926811	Pressure reducer	1
12	25962	Pneumatic horn (makrafon) NPT kit	1
13	926815	Pneumatic time delay, Oxexo, 145 psi	1

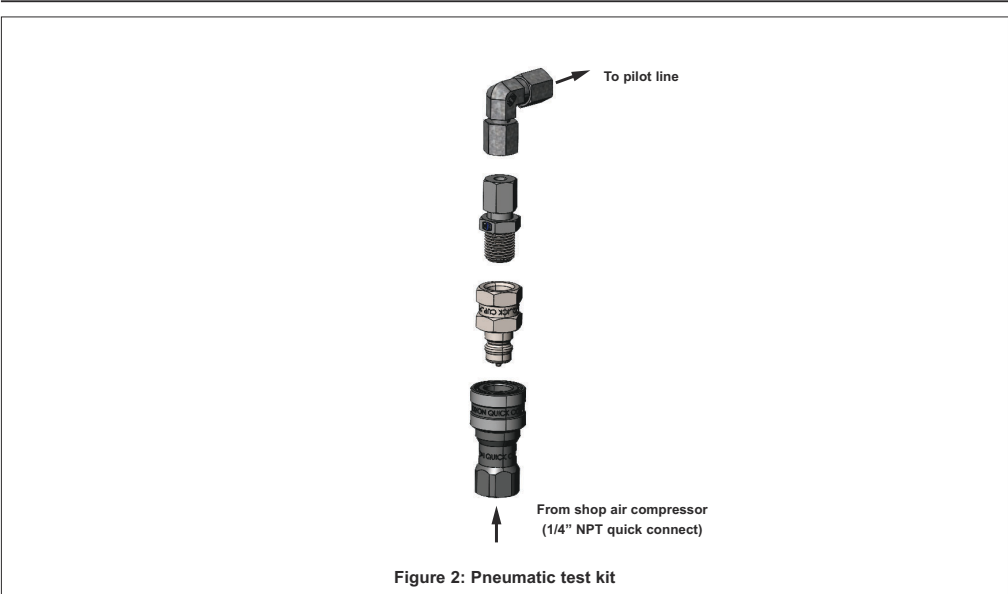

Figure 2: Pneumatic test kit

17.27 Pressure Reducer (PR)

1. DESCRIPTION

The pressure reducer reduces the high pressure of the extinguishing agent in the upstream pipework via an orifice. The diameter of the orifice depends on the flow rate of the extinguishing agent and the pipework. The calculation of the diameter is carried out via the Viking calculation program. See the Viking website for more information.

The pressure reducer may only be used in accordance with system approval in stationary argon and nitrogen fire extinguishing systems. The pressure reducer has maximum working pressure of 235 bar. It is installed between the upstream pipework and the downstream pipework.

The pressure reducer is available in two different variants:

- Pressure reducer with orifice for hole diameter of 3 mm (0.118 in.) to 46 mm (1.811 in.)
- Pressure reducer with orifice and protective screen for hole diameters of 1 mm (0.039 in.) to 2.9 mm (0.114 in.)

The protective screen prevents any debris or scaling from blocking the smaller orifice diameters.

2. LISTINGS AND APPROVALS

 cULus Listed - EX5248 (Oxeo PR)

 FM Approved: Oxeo PR

3. TECHNICAL DATA

Specifications:

Operating medium: Argon (IG-01), Nitrogen (IG-100)
 Working pressure: 5294 psi (365 bar)
 Temperature range: -4 °F to 122 °F (-20 °C to +50 °C)
 Thread Rc: in accordance with ANSI/ASME B1.20.1 - NPT

Material standards:

Material: Steel
 Finish: Galvanized, EN 12329 - FE//Zn12
 Test certificate: EN 10204 - 3.1 (material)



Designation	Part no.
Oxeo pressure reducers	See table 1

 **WARNING:** Cancer and Reproductive Harm-
www.P65Warnings.ca.gov

4. ORDERING PROCEDURE

1. Select a base part number with the required inlet / outlet size and pressure rating.
2. Add the suffix for the desired orifice size

NOTE: Orifice sizes range from 1.0 mm to 35.0 mm. To select the suffix for the correct orifice size, convert the metric diameter to inches and round to three decimal places. This four digit number will be the suffix for the given orifice size.

EXAMPLE: 25013-0118 = Pressure reducer 2" NPT / 2" NPT with protective screen with an orifice of 0.118" (3.0 mm).

Table 1: Ordering table			
Designation	Maximum pressure	Base part number	Orifice diameter range
3/4" BSPT / 3/4" NPT with protective screen*	2901 psi (200 bar)	25011	0.039" (1.0 mm) to 0.114" (2.9 mm)
2" NPT / 2" NPT with protective screen		25013	
2" NPT / 2-1/2" NPT with protective screen		25015	
2" NPT / 3" NPT with protective screen		25017	
3/4" BSPT / 3/4" NPT*	4351 psi (300 bar)	25012	0.118" (3.0 mm) to 1.379" (35.0 mm)
2" NPT / 2" NPT		25014	
2" NPT / 2-1/2" NPT		25016	
2" NPT / 3" NPT		25018	

*Configurations available in single tank systems only.

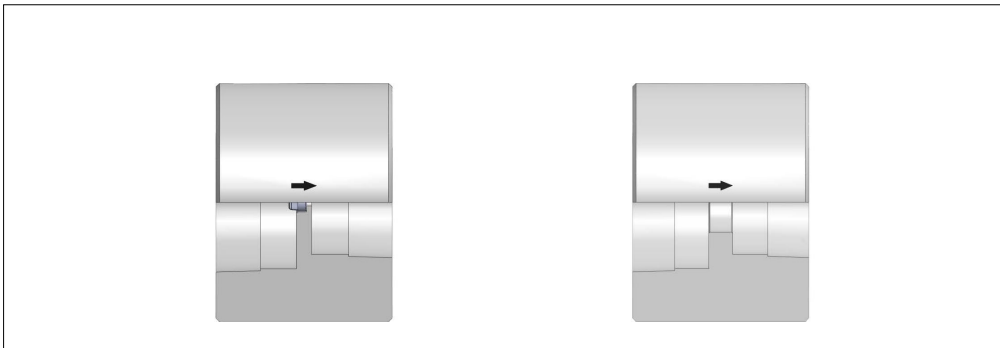

Figure 1: Pressure reducer with and without protective screen

17.28 Pneumatic Time Delay

1. DESCRIPTION

The pneumatic time delay is for use in the Oxexo inert gas fire extinguishing system. The time delay is used to delay the discharge of the extinguishing agent in the event of a fire and create a window for egress from the affected zone. The time delay unit is always used when the employers' liability insurance association demands a safe delay of the control gas for reason of personal safety.

The time delay unit mainly consists of a 3/2-way piston slide valve with a G1/8 internal thread for the pneumatic connections. The time delay can be set between 10 and 60 seconds using a hexagon socket wrench.

In stand-by mode, the input is disabled and the output is vented, no pressure build-up can occur on the cylinder side. After triggering, the pressure chamber is filled via an internal channel with pilot control gas. After the delay time is reached, the piston slide is actuated and the inlet pressure is applied to the outlet. The pneumatic time delay valve closes automatically when the inlet pressure drops.

NOTE: All pneumatic controls must be tested with shop air pressure prior to system commissioning. Use the pneumatic test kit (Figure 2) to convert the pilot lines to 1/4" NPT. Ensure the time delay is installed in the proper position.

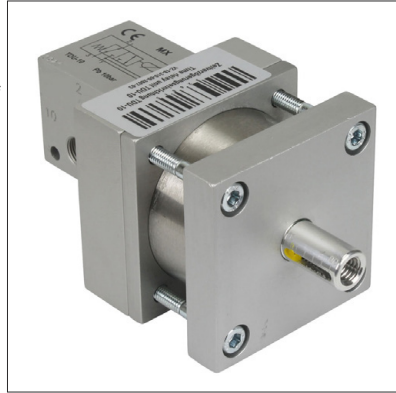

2. LISTINGS AND APPROVALS



cULus Listed - EX5248 (Oxexo PR CF)



FM Approved: Oxexo PR CF

Designation	Part no.	Weight
Pneumatic time delay u*	926815	1.5 lbs (0.66 kg)
Pneumatic test kit	25761	--

* 'u' designates approved universal use in the Americas.



WARNING: Cancer and Reproductive Harm-
www.P65Warnings.ca.gov

3. TECHNICAL DATA

3.1 - Specifications and Ratings	
Parameter	Value
Type	Pneumatic time delay
Valve type	3/2-way piston slide valve, operated with signal connection
Operating medium	Argon
	Nitrogen
Working pressure	10 bar (145 psi)
Time delay	
Factory adjustment	30 seconds, secured with sealing wax
Setting range*	10 seconds to 60 seconds
	Time settings made at 7.5 bar
Flow rate	21.19 cfm (600 L/min)
Temperature range	32 °F to 122 °F (0 °C to +50 °C)
Connection Pneumatic	2x internal thread G 1/8
	Push-in fitting for pneumatic pilot hose PTS-10
Installation	Wall installation
Installation position	See operating instructions
Time delay unit	Complies with EN 12094-2
*In the event of changes to the factory adjustment, the new delay time must be entered smudge-proof on the housing and the sealing wax must be renewed.	

Units:
Inches (mm)

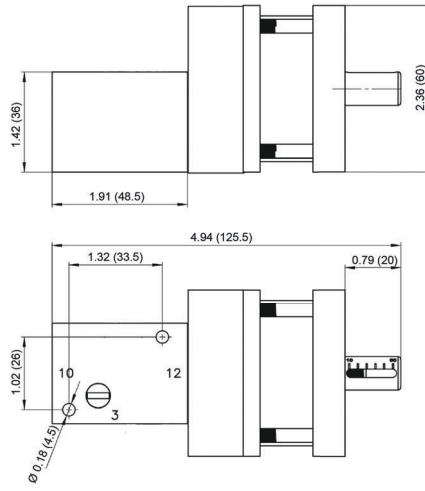

Figure 1: Dimensions



Figure 2: Pneumatic test kit

17.29 Pneumatic Horn

1. DESCRIPTION

The pneumatic horn is a pneumatically operated acoustic alarm device for use in gas extinguishing systems in accordance with the system approval. This alarm device emits a constant loud sound prior to system activation in order to warn personnel present in the application area to evacuate immediately.

The pneumatic horn includes both a NPT conversion kit and brackets. The pneumatic horn complies with EN 12094-12.

2. LISTINGS AND APPROVALS

 cULus Listed - EX5248 (Oxeo PR CF)

 FM Approved: Oxeo PR CF

3. TECHNICAL DATA

Specifications

Operating medium: N₂

Connection: precision drawn steel pipe 6 x 1 with converters for 1/2" OR pilot hoses

Temperature Range:

- Operating: -4 °F to 302 °F (-20 °C to 150 °C)
- Transport and storage: -4 °F to 131 °F (-20 °C to 55 °C)

Working Pressure: 116 psi to 160 psi (8 bar to 11 bar)¹

Consumption rates

At constant 145 psi (10 bar):

- N₂: approx. 0.74 oz/min (21 g/min)

At constant 1015 psi (70 bar):

- N₂: approx. 4.4 oz/min (124 g/min)

Installation Position: sound outlet points downward

Pneumatic horn complies with EN 12094-12

Marking

Part number: 25962

Material Standards

Conversion Kit² (installed hand tight upon shipment, customer assembly required):

- Swivel union, 6 mm drawn tubing (M12x1.5)
- Adapter, male 1/4" NPT stud to 6mm drawn tubing (M12x1.5)
- Steel adapter, female 1/4" NPT to male 1/2" NPT

NOTE: Pneumatic horn intended for indoor use only

¹ Overpressure-proof up to 2030 psi (140 bar)

² All components comprised of zinc plated steel

4. INSTALLATION

The pneumatic horn is to be installed with its sound outlet pointing downward. Connection to be used with precision drawn steel pipe 6 x 1. All components are delivered assembled hand-tight.

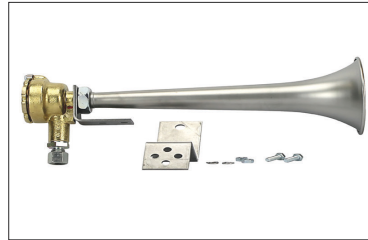

Designation	Part no.	Weight
Pneumatic horn	25962	2.54 lbs (1.15 kg)

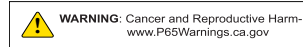
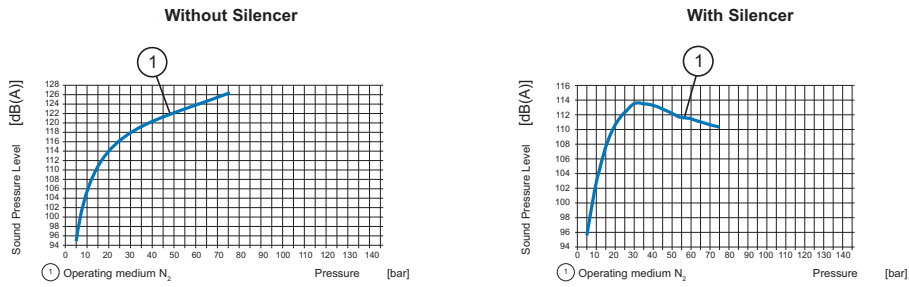

TABLE 1: PNEUMATIC HORN TECHNICAL DATA					
Operating Mediums: N ₂					
Operational Temperature Range			Working Pressure Range*		
Unit	Low	High	Unit	Low	High
°F	-4	572	PSI	116	1015
°C	-20	300	bar	8	70
Operating Medium Consumption Rates					
Description	N ₂				
	oz/min		g/min		
Consumption at constant 145 psi (10 bar)	0.74		21		
Consumption at constant 1015 psi (70 bar)	4.4		124		
Notes					
* Overpressure-proof up to 2030 psi (140 Bar).					



Figure 4: A-Weighted Sound Pressure Levels



Note: The curves shown above were determined in the laboratory. Due to the influencing factors given in situ, the real values may deviate from the curves.

Figure 5: Component Dimensions
Dimensions in inches (mm)

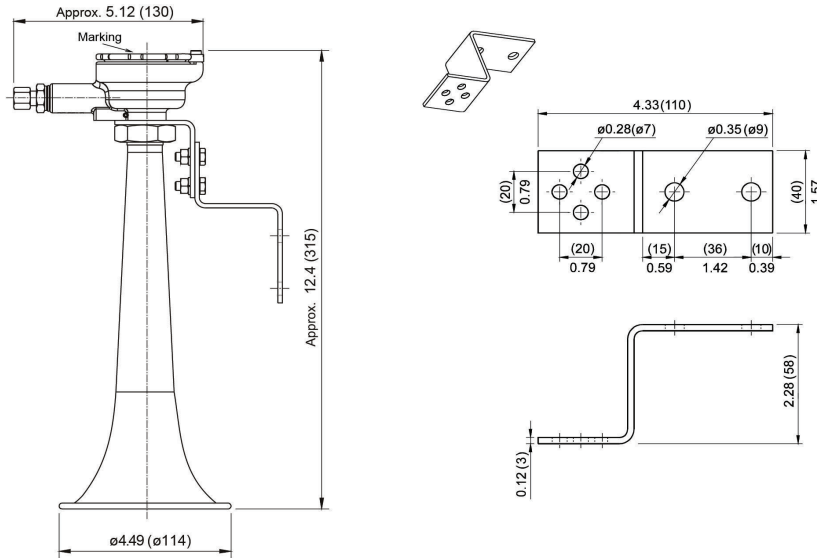
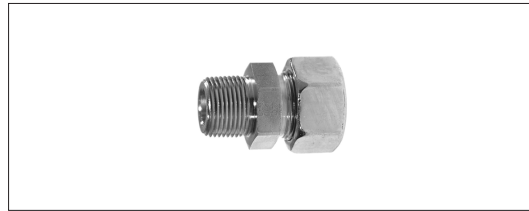

Figure 6: NPT Conversion Kit Components

Swivel union, 6 mm drawn tubing (M12x1.5)



Adapter, male 1/4" NPT stud to 6 mm drawn tubing (M12x1.5)



Steel adapter, female 1/4" NPT to male 1/2" NPT



Union, male 6 mm to male 6 mm



17.30 MZ-1

1. DESCRIPTION

The MZ-1 is the modular control unit within the Oxexo multi-zone system, and is used for ensuring the correct amount of extinguishant is deployed to the correct extinguishing zone. These quantities can be adjusted to fulfill the design requirements of each extinguishing zone. A maximum of 10 zones can be protected with the accompanying 5 extinguishing quantities. The control unit is intended for the use in IG-01 and IG-100 fire extinguishing systems. The MZ-1 controls all pneumatic system components via control gas from a pilot cylinder.

The MZ-1 is available in two versions, one with a changeover device for main and reserve tanks, and one without. Refer to the appropriate ordering table for each version.

2. LISTINGS AND APPROVALS



cULus Listed - EX5248 (Oxexo PR CF)



FM Approved: Oxexo PR CF

3. TECHNICAL DATA

Specifications

Operating medium: Nitrogen (IG-100)
 Working pressure: 145 psi to 363 psi (10 bar to 25 bar)
 Temperature range: -4 °F to 131 °F (-20 °C to +55 °C)
 IP code: IP54

Electrical Data

Nominal voltage for coil: 24 V DC
 Conductor cross-section:
 - Conductor, rigid: 0.2 mm² - 2.5 mm² (AWG 24 - AWG 14)
 - (flexible without wire end ferrule: 0.2 mm² - 2.5 mm²
 - (flexible with wire end ferrule: 0.25 mm² - 2.5 mm²
 - according to UL/CUL: min. AWG 26, max. AWG 12
 Stripping length: 0.39" (10 mm)

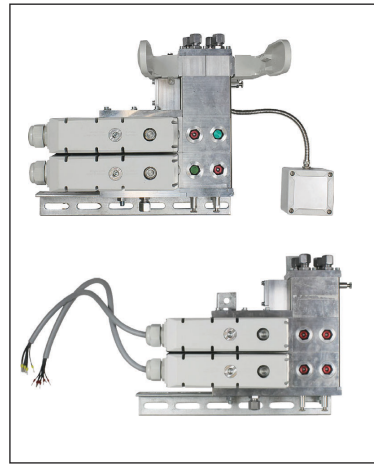

Designation	Part no.*	Weight
MZ-1 with main/ reserve changeover	930284	84.9 lb (38.5 kg)
MZ-1 without main/ reserve changeover	930212	78.5 lb (35.6 kg)

*Part numbers for the 5x5 configuration are given. For custom configurations, refer to tables 1 and 2.

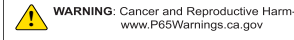

TABLE 1: Ordering information MZ-1 with main/reserve changeover					
NOTE: ONLY THE 5X5 CONFIGURATION (930284) IS AVAILABLE AS A STOCKED ITEM. ALL OTHERS ARE NOT STOCKED AND ADDITIONAL LEAD TIMES MAY APPLY.					
Number of extinguishing zones	Part numbers				Weight lb (kg)
	2 tank divisions	3 tank divisions	4 tank divisions	5 tank divisions	
2	930269*	930270*	930271*	930272*	33.1 (15.0) 38.7 (17.4) 44.3 (20.1) 49.8 (22.6)
3	930273*	930274*	930275*	930276*	41.7 (18.9) 48.3 (21.9) 54.9 (24.9) 61.5 (27.9)
4	930277*	930278*	930279*	930280*	50.0 (22.7) 57.8 (26.2) 65.5 (29.7) 73.2 (33.2)
5	930281*	930282*	930283*	930284**	58.6 (26.6) 67.5 (30.6) 77.4 (35.1) 84.9 (38.5)
6	930285	930286	930287	930288	67.2 (30.5) 76.9 (34.9) 86.9 (39.4) 96.6 (43.8)
7	930289	930290	930291	930292	75.8 (34.4) 86.6 (39.3) 97.4 (44.2) 109 (49.2)
8	930293	930294	930295	930296	84.2 (38.2) 96.1 (43.6) 108 (49.1) 120 (54.5)
9	930297	930298	930299	930300	92.8 (42.1) 106 (47.9) 119 (53.9) 132 (59.8)
10	930301	930302	930303	930304	101 (46.0) 115 (52.3) 129 (58.7) 144 (65.1)
*Not available in the U.S.					
**Stocked item. All others are not stocked.					

TABLE 2: Ordering information MZ-1 without main/reserve changeover					
NOTE: ONLY THE 5X5 CONFIGURATION (930212) IS AVAILABLE AS A STOCKED ITEM. ALL OTHERS ARE NOT STOCKED AND ADDITIONAL LEAD TIMES MAY APPLY.					
Number of extinguishing zones*	Part numbers				Weight lb (kg)
	2 tank divisions	3 tank divisions	4 tank divisions	5 tank divisions	
2	930197*	930198*	930199*	930200*	28.6 (13.0) 33.5 (15.2) 38.5 (17.5) 43.4 (19.7)
3	930201*	930202*	930203*	930204*	37.1 (16.8) 43.1 (19.5) 49.1 (22.3) 55.1 (25.0)
4	930205*	930206*	930207*	930208*	45.6 (20.7) 52.6 (23.9) 59.8 (27.1) 66.8 (30.3)
5	930209*	930210*	930211*	930212**	54.2 (24.6) 62.2 (28.2) 71.5 (32.5) 78.5 (35.6)
6	930213	930214	930215	930216	62.7 (28.4) 71.8 (32.6) 81.1 (36.8) 90.2 (40.9)
7	930217	930218	930219	930220	71.2 (32.3) 81.4 (36.9) 91.7 (41.6) 102 (46.2)
8	930221	930222	930223	930224	79.8 (36.2) 90.9 (41.3) 102 (46.5) 114 (51.5)
9	930225	930226	930227	930228	88.3 (40.1) 101 (45.6) 113 (51.3) 125 (56.8)
10	930229	930230	930231	930232	96.8 (43.9) 110 (49.9) 124 (56.1) 137 (62.1)
*Not available in the U.S.					
**Stocked item. All others are not stocked.					

Figure 1: MZ-1 with main/reserve switchover dimensions

Dimensions in inches (mm)

Example for 5 extinguishing zones and 5 extinguishant quantities

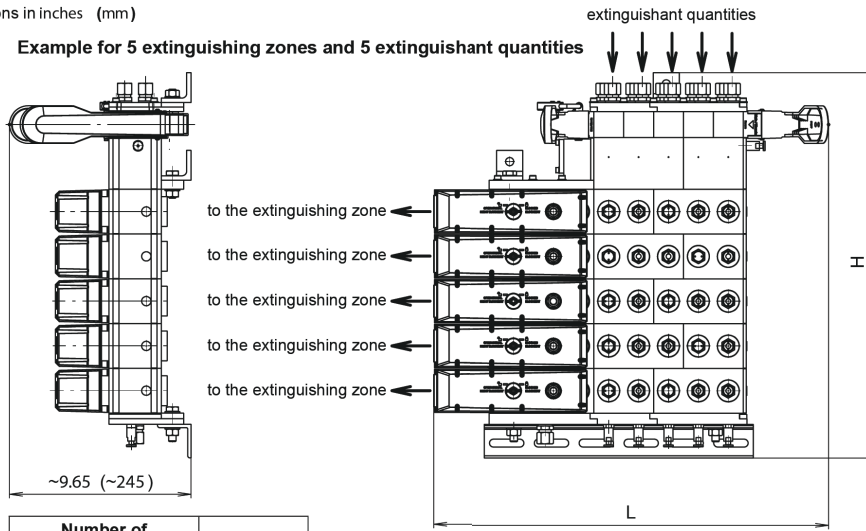

Number of extinguishing zones	H
2	13.23 (336)
3	15.59 (396)
4	17.95 (456)
5	20.31 (516)
6	22.68 (576)
7	25.04 (636)
8	27.40 (696)
9	29.76 (756)
10	32.13 (816)

Number of tank divisions	L
2	16.93 (430)
3	18.50 (470)
4	20.08 (510)
5	21.65 (550)

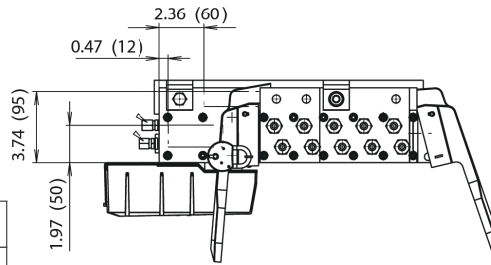
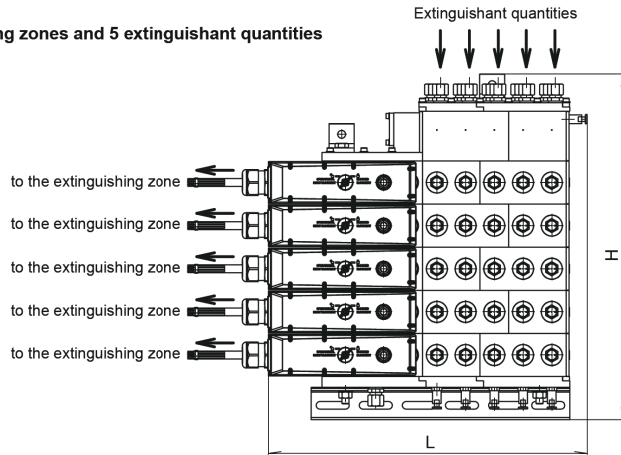
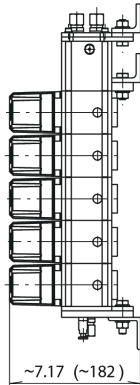

Figure 2: MZ-1 without main/reserve switchover dimensions

Dimensions in inches (mm)

Example for 5 extinguishing zones and 5 extinguishant quantities



Number of extinguishing zones	H
2	11.85 (301)
3	14.21 (361)
4	16.57 (421)
5	18.94 (481)
6	21.30 (541)
7	23.66 (601)
8	26.02 (661)
9	28.39 (721)
10	30.75 (781)

Number of tank divisions	L
2	14.21 (361)
3	15.79 (401)
4	17.36 (441)
5	18.94 (481)

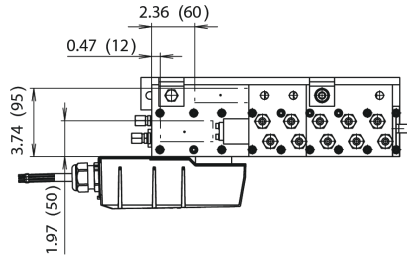

17.31 Selector Valve

1. DESCRIPTION

The Oxexo selector valve is designed for use in inert gas fire extinguishing systems. The selector valve serves as a valve for selectively flooding extinguishing zones in the case of fire.

The selector valve consists primarily of a ball valve and a rotary drive. These two components are connected to each other by a bridging fitting and a shaft adapter. Once a fire is detected in one of the extinguishing zones of a multi zone system, the selector valve associated with the extinguishing zone is opened by the pneumatic rotary drive and the extinguishing agent flows to the nozzle pipework of the relevant extinguishing zone.

2. LISTINGS AND APPROVALS



cULus Listed - EX5248 (Oxexo PR CF)



FM Approved: Oxexo PR CF

Designation	Part number.
Oxexo CF selector valve assembly 1"	934713D
Oxexo CF selector valve assembly 1.5"	934714D
Oxexo CF selector valve assembly 2"	934715D
Oxexo CF selector valve assembly 2.5"	934826D
Oxexo CF selector valve assembly 3"	934827D
Oxexo CF selector valve assembly 4"	934828D
Oxexo PR selector valve assembly	24815

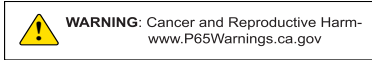

3. TECHNICAL DATA

3.1 - Specifications and Ratings - PR system	
Parameter	Value
Operating medium	Argon
	Nitrogen
Working pressures:	
-Selector valve	5294 psi (365 bar)
-Pneumatic rotary drive	145 psi (10 bar)
Temperature range	-4 °F to 131 °F (-20 °C to 55 °C)
Control pressure	130.5 to 145 psi (9 to 10 bar)
Markings	Flow direction arrow
	CE
	VDS
Pneumatic rotary drive connection	G1/4, ISO 228-1
Type	PS226-Z11-R200
Protection type	Plastic, glass fiber reinforced
Protection type	IP 66, IP 67
Contact material	Silver
Switch system	Snap action contact, NC contact (positive opening)
Switching elements	Normally open (NO) contact, normally closed (NC) contact
Activation	Roller pressure bolt
Connection type	Screw connection
Service life	20 years
Connection cross-section	min. 0.34 mm ²
	max. 1.5 mm ²
Cable entry	2 x M20 x 1.5
U _i	300 V
I _{the}	10 A
Utilization category	AC-15: 230 V / 3 A
Short-circuit protection	6 A gG D fuse

3.2 - Specifications and Ratings - CF system	
Parameter	Value
Operating medium	Argon
	Nitrogen
Working pressures: -Selector valve -Pneumatic rotary drive	2031 psi (140 bar) 145 psi (10 bar)
Temperature range: -Selector valve -Limit switch	-4 °F to 131 °F (-20 °C to 55 °C) -4 °F to 122 °F (-20 °C to 50 °C)
Activation pressure	130.5 to 145 psi (9 to 10 bar)
Test pressure	3045 psi (210 bar)
Limit switch type	PS226-Z11-R200
Housing	Plastic, glass fiber reinforced
IP code	IP 66, IP 67
Contact material	Silver
Switch system	Spring control, actuator type C to DIN EN 50047
Switching elements	Normally open (NO) contact, normally closed (NC) contact
Connection type	Screw connection
Service life	20 years
Conductor cross-section	Minimum: 0.75 mm ² Maximum: 2.5 mm ²
Cable entry	2 x M20 x 1.5
Utilization category	AC-15: 240 VAC / 3 A DC-13: 24 VDC / 3 A
Short-circuit protection	6 A gG D fuse



**The Viking Corporation
210 N. Industrial Park Dr.
Hastings, MI 49058
USA
Phone: 269-945-9501
Fax: 269-818-1680
www.vikinggroupinc.com
www.supplynet.com**

**Document ID: F_021023
Revision: 03
Release date: 08/2024
Language: English (U.S.)**