



TECHNICAL DATA

MAINTENANCE AIR COMPRESSOR MODEL H-1

The Viking Corporation, 5150 Beltway Dr SE, Caledonia, MI 49316

Telephone: 269-945-9501 Technical Services: 877-384-5464 Fax: 269-818-1680 Email: techsvcs@vikingcorp.com

Visit the Viking website for the latest edition of this technical data page www.vikinggroupinc.com

1. DESCRIPTION

The Viking Model H-1 Maintenance Air Compressor is an electric motor-driven, air-cooled, single-stage, oil-less compressor. The unit is equipped with a check valve and provides a regulated (by pressure switch setting) and restricted (60 Cycle - 3.03 SCFM average free air from 0 to 40 psi [0-2.8 bar] gauge) or (50 Cycle - 2.50 SCFM average free air from 0 to 40 psi [0-2.8 bar] gauge) air supply. A pressure relief valve is factory installed to prevent pressurizing the system piping above 125 PSI (8.6 bar). The Model H-1 is for use when system pressures are required to be over 20 PSI (1.4 bar).

The Viking Model H-1 Maintenance Air Compressor may be used to automatically maintain air pressure in a dry system after the system has been filled from a non-continuous air supply. It may be used as a basic air supply for dry systems with a capacity of 250 gallons (946 L-60 Hz) and 206 gallons (780 L-50 Hz) or smaller.

1.1 FEATURES

- Carbon steel mounting bracket with stainless steel adjustable straps (fits pipe sizes of 2" - 6" (50.8 mm - 152.4 mm))
- Adjustable pressure switch
- Check valve factory installed at the compressor outlet.
- Pressure relief valve factory installed at the compressor outlet to prevent pressurizing the system piping above 125 PSI (8.6 bar).
- Permanently lubricated bearings
- Self-lubricating pistons
- Stainless steel valves
- Automatically resetting thermal protection
- Proof-tested to maintain accuracy and withstand occasional maximum pressure of 250 PSI (17.2 bar) to allow hydrostatic testing after installation

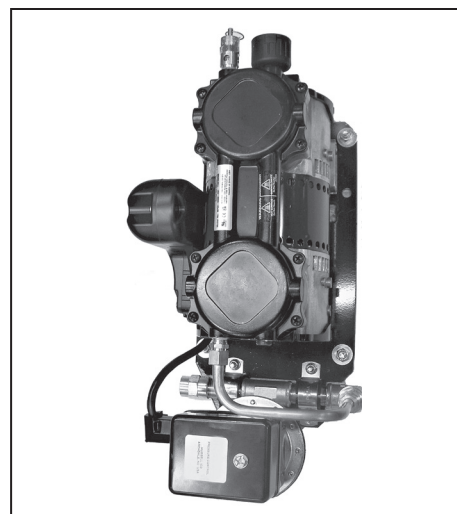

⚠ WARNING

This product can expose you to chemicals including Cumene, which is known to the State of California to cause cancer and birth defects or other reproductive harm. For more information, go to www.P65Warnings.ca.gov

2. LISTINGS AND APPROVALS

 **cULus Listed:** Classes VDUR and VDUR7 - 60 Hz units only

 **FM Approved:** Class 1032 - all units

3. TECHNICAL DATA

TABLE 1: ORDERING INFORMATION AND SPECIFICATIONS

Parameter	Part Number		
	25833	25834	25835
Voltage	115 V, Single phase	208-230 V Single phase	208-230 V Single phase
AC	60 Hz	60 Hz	50 Hz
Service Factor Amperage	6.8	3.4	3.4
Average Free air flow	3.03 SCFM	3.03 SCFM	2.50 SCFM
Pressure Range	15-75 PSI (1.0 to 5.2 bar)		
Pressure Differential	2-8 PSI (0.14 to 0.55 bar)		
Pressure Switch Factory Setting	Cut-in: 30 PSI (2.1 bar) Cut-out: 40 PSI (2.8 bar)		
Horsepower	1/3 hp, Direct drive		
Recommended ambient temperature range	40 °F to 110 °F (4.4 °C to 43 °C)		
Safety Relief valve setting	125 PSI (8.6 bar)		
Shipping weight	37 Lbs. (17 Kg)		
System capacity @ 40 PSI (2.8 bar)	250 gallons (946 L)		



TECHNICAL DATA

MAINTENANCE AIR COMPRESSOR MODEL H-1

The Viking Corporation, 5150 Beltway Dr SE, Caledonia, MI 49316

Telephone: 269-945-9501 Technical Services: 877-384-5464 Fax: 269-818-1680 Email: techsvcs@vikingcorp.com

Visit the Viking website for the latest edition of this technical data page www.vikinggroupinc.com

4. INSTALLATION

4.1 GENERAL SAFETY INFORMATION

This unit is intended for installation indoors for use on dry sprinkler systems in accordance with the latest editions of the Standard for Installation of Sprinkler Systems, NFPA 13, the National Electrical Code (NEC), NFPA 70. The compressor must be installed in an area not exposed to the weather, freezing temperatures, or physical damage. In addition, follow the guidelines listed below:

- Read and understand all manuals included with this product. Thoroughly familiarize yourself with the controls and proper use of the product before performing any work.
- Follow all local electrical and safety codes as well as NEC, Occupational Safety and Health Act (OSHA), and NFPA.
- Only persons familiar with these rules of safe operation should be allowed to use the product.
- Keep visitors away and NEVER allow children in the work area.
- Wear safety glasses and use hearing protection when operating the product.
- Do not stand on, or use the product as a hand-hold.
- Check all fasteners at frequent intervals for tightness.
- Periodic inspection/testing of this product is required. Consult the installer and local codes to ensure all requirements are met.
- The air compressor should be sized to restore and maintain the air pressure in the sprinkler system in accordance with the requirements of NFPA 13.
- When corrosive atmospheres and/or contaminated water supplies are present, it is the owner's responsibility to verify compatibility with the air maintenance compressor and associated equipment.
- The compressor outlet includes a check valve.
- For low volume systems, such as pneumatic release lines, it is recommended to install a receiver tank between the compressor and the system being supplied.

4.2 SAFETY NOTES

⚠ WARNINGS

- **Do not operate this compressor if damaged during shipment, handling, or use. Damage may result in bursting and cause injury or property damage.**
- **This compressor is NOT equipped and should NOT be used "as-is" to supply breathing quality air. Motors, electrical equipment and controls can cause electrical arcs that will ignite a flammable gas or vapor. Never operate or repair in or near a flammable gas or vapor. Never store flammable liquids or gases near the compressor.**
- **These compressors are suitable for pumping only atmospheric air. As defined in Compressed Gas Association Pamphlet G-7, page 3, atmospheric air is a mixture of elements and compounds where nitrogen and oxygen comprise more than 99% with all other trace gases comprising less than 1%. DO NOT USE THIS COMPRESSOR IN CONTAMINATED ENVIRONMENTS OR FOR PUMPING MIXTURES OTHER THAN ATMOSPHERIC AIR.**
- **Compressed air contains liquid water and is saturated with water vapor, which can freeze. Do not connect the compressor outlet to freezer rooms or systems exposed to temperatures below freezing. If the system connects to a freezer room or area exposed to freezing temperatures, a Dry Air Pac™ should be used.**

⚠ WARNING

DO NOT ATTEMPT TO CHANGE THE SAFETY RELIEF VALVE SETTING.



TECHNICAL DATA

MAINTENANCE AIR COMPRESSOR MODEL H-1

The Viking Corporation, 5150 Beltway Dr SE, Caledonia, MI 49316

Telephone: 269-945-9501 Technical Services: 877-384-5464 Fax: 269-818-1680 Email: techsvcs@vikingcorp.com

Visit the Viking website for the latest edition of this technical data page www.vikinggroupinc.com

⚠ CAUTION

- The compressor pressure relief valve is set to open at 125 PSI (8.6 bar). Compressor will run continuously when the switch is set at or above 125 PSI (8.6 bar).
- Cycle the switch to determine actual setting before proceeding with re-adjustment.

NOTICES

- Do not connect the compressor intake to a freezer room.
- Locate the compressor in a clean, well-ventilated area where the air is relatively cool, clean, and dry.
- A 110°F (43°C) maximum and 40°F (4.4°C) minimum temperature for surrounding and inlet air are recommended.
- Provide at least 12 to 18 inches (305 mm to 457 mm) from any wall or other obstruction that will interfere with airflow through the motor's fan. Blocking airflow through the fan may cause the compressor to over heat.
- This compressor is designed for non-lubricated service. Bearings are permanently lubricated. Do not lubricate any part of the compressor or motor.
- Failure to install a separate check valve to prevent water backflow voids the Warranty.
- Single-phase motors include internal thermal overload protection, which has an automatic reset device.
- Do not run two phases of a three phase supply through the pressure switch. Serious damage can result.

4.3 INSTALLATION PROCEDURE

The Model H-1 Maintenance Air Compressor may be installed vertically or horizontally. Recommended installation is vertical with discharge facing down. There must be at least 12" (305 mm) of clearance from sidewalls, floors, and ceilings to ensure that the unit will operate correctly. Firmly mount the unit to a stable, rigid surface by bolting it through the slotted holes in the motor mounting base. To "riser" mount the unit, a vertical mounting kit is available. The kit is provided with stainless steel adjustable straps and hardware that make it suitable for mounting to pipe sizes between 2" and 6" (50.8 mm and 152.4 mm) (refer to Figure 2).

1. Place the "V" notches of the mounting bracket against the riser.
 - a. Place the mounting straps around the riser and through the square slots provided in the mounting base.
 - b. Tighten the mounting straps.
2. Mount the compressor unit to the mounting bracket. Tighten all bolts—four mounting bolt sets are provided.
3. Install the air supply piping from the 1/2" (13 mm) NPT outlet tee of the compressor to the dry system piping.
 - a. When connecting to dry systems equipped with a Viking Model D-2 Accelerator or Model E-1 Accelerator and Model B-1 Anti-flood Device, refer to the appropriate Accelerator trim chart. Connect the compressor outlet to the trim as indicated in the trim chart.
 - b. Apply a small amount of pipe-joint compound or tape to the external threads of all pipe connections required. Take care not to allow any compound, tape, or other foreign matter inside any of the nipples or compressor outlet.
4. Connect the electrical supply from an uninterrupted, dedicated circuit. The field wiring for the unit is made inside the pressure regulating switch. The switch is factory preset and sealed to cutout at 40 PSI (2.8 bar). DO NOT ADJUST ABOVE 60 PSI (4.1 bar).

⚠ CAUTION

Inadequate wiring size can cause insufficient voltage at the compressor during start-up. Overheating and damage to the motor and controls may result.

- a. The compressor motor and pressure switch are factory wired.
- b. Remove the access cover shown in Figure 2 (screw driver is required).
- c. Connect wires as shown in Figure 1 wiring diagram.

NOTE: Comply with all national and local codes and requirements of the Authority Having Jurisdiction.
- d. Reinstall the switch access cover prior to operating the compressor.
- e. DO NOT exceed the electrical ratings shown on the switch or motor nameplates.

5. Test the compressor pressure switch setting. Note the pressure at which the compressor starts and shuts off. Adjust the



TECHNICAL DATA

MAINTENANCE AIR COMPRESSOR MODEL H-1

The Viking Corporation, 5150 Beltway Dr SE, Caledonia, MI 49316

Telephone: 269-945-9501 Technical Services: 877-384-5464 Fax: 269-818-1680 Email: techsvcs@vikingcorp.com
Visit the Viking website for the latest edition of this technical data page www.vikinggroupinc.com

pressure switch to the required setting.

6. Pressure switch adjustment procedure (see to Figure 1):

CAUTION

Failure to use the pressure switch may result in overpressure of the compressor or other components in the system. Overpressure of the compressor may result in blown head gaskets or other damage.

- a. The large metallic screw (A) is used first to adjust the cut-in pressure (the point at which the compressor comes on as system pressure decreases). The small metallic screw (B) is used to adjust the cut-out pressure (the point at which the compressor shuts off on rising pressure).
- b. With no pressure on the system, energize the circuit. The compressor should start immediately.
- c. Allow the compressor to run until it shuts down. Note the pressure reading (cut-out pressure). Bleed air out of the system until the compressor restarts. Note the pressure reading (cut-in pressure).
- d. If the cut-in point is not satisfactory, adjust the large metal screw (A) after the compressor stops (clockwise increases the pressure). Repeat the bleeding and adjusting until the cut-in point is correct. Each time the compressor stops, note the cut-out point, which will change with each adjustment of the large metallic screw.
- e. Adjust the small metallic screw (B) to raise (clock-wise) or lower the cut-out pressure from the last noted reading and repeat the bleeding operation. The cut-in point should remain the same each time.

5. INSPECTIONS, TESTS AND MAINTENANCE

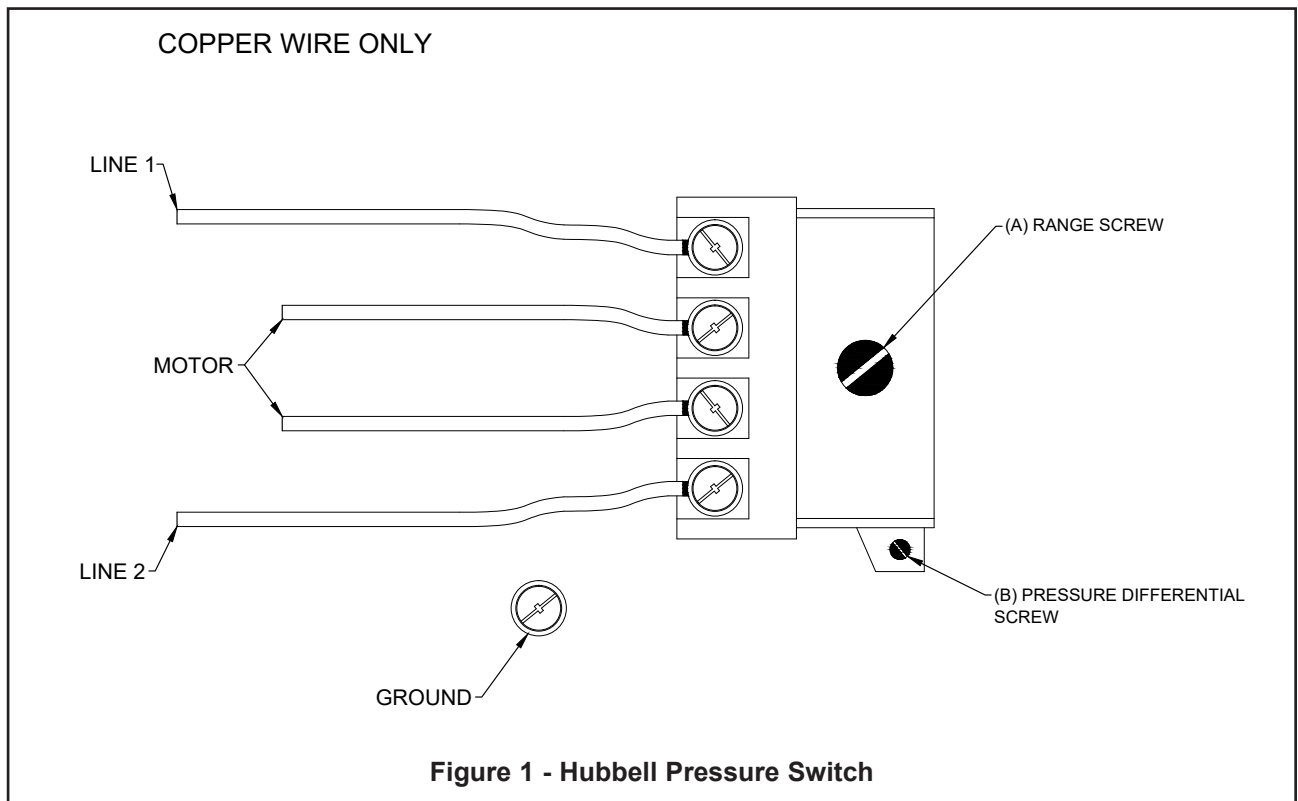



TECHNICAL DATA

MAINTENANCE AIR COMPRESSOR MODEL H-1

The Viking Corporation, 5150 Beltway Dr SE, Caledonia, MI 49316

Telephone: 269-945-9501 Technical Services: 877-384-5464 Fax: 269-818-1680 Email: techsvcs@vikingcorp.com

Visit the Viking website for the latest edition of this technical data page www.vikinggroupinc.com

⚠ WARNING

DISCONNECT, TAG, AND LOCK OUT POWER SOURCE THEN RELEASE ALL PRESSURE FROM THE SYSTEM BEFORE ATTEMPTING TO INSTALL, SERVICE, RELOCATE OR PERFORM ANY SERVICE.

NOTICE

The owner is responsible for maintaining the fire protection system and devices in proper operating condition. For minimum maintenance and inspection requirements, refer to recognized standards such as those produced by NFPA, LPCB, and VdS, which describe care and maintenance of sprinkler systems. In addition, the "Authority Having Jurisdiction" may have additional maintenance, testing, and inspection requirements that must be followed.

5.1 INSPECTIONS

It is imperative that the system is inspected and tested on a regular basis. The frequency of the inspections may vary due to contaminated or corrosive water supplies and corrosive atmospheres. In addition, the alarm devices or other connected equipment may require more frequent inspections. Refer to the technical data, system description, applicable codes, and Authority Having Jurisdiction for minimum requirements.

WEEKLY

- Drain condensate from receiver and traps.
- Check for unusual noise or vibration.
- Clean air filters. – Do not clean filters with petroleum based products.
- Clean all external parts of the compressor and motor.

MONTHLY

- Manually test safety relief valve.
- Inspect air system for leaks and tighten nuts and cap screws as required.

QUARTERLY

- Change filters.

5.2 MAINTENANCE

The compressor motor is equipped with thermal protectors that reset automatically.

⚠ WARNING

Disconnect electrical power before servicing. Thermal protector can automatically start the motor when the device resets.

1. The motor compressor unit should be kept dirt-free.
2. The compressor inlet filter should be cleaned or replaced as required.
 - a. To inspect the inlet filter, pull the plastic cap to remove it from the filter case.
 - b. The filter can be removed for inspection. DO NOT clean filter elements with petroleum-based products.
 - c. Re-install the filter and cap. DO NOT operate the compressor without a filter.
3. DO NOT lubricate the compressor or motor. The bearings are permanently lubricated and sealed.

6. AVAILABILITY

The air compressor is available through a network of domestic and international distributors. See the The Viking Corporation Web site for closest distributor or contact The Viking Corporation.

7. GUARANTEES

For details of warranty, refer to Viking's current list price schedule or contact Viking directly.



TECHNICAL DATA

**MAINTENANCE AIR
COMPRESSOR MODEL H-1**

The Viking Corporation, 5150 Beltway Dr SE, Caledonia, MI 49316
 Telephone: 269-945-9501 Technical Services: 877-384-5464 Fax: 269-818-1680 Email: techsvcs@vikingcorp.com
 Visit the Viking website for the latest edition of this technical data page www.vikinggroupinc.com

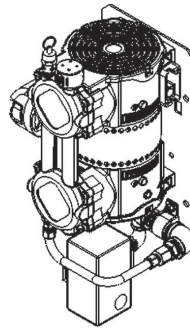
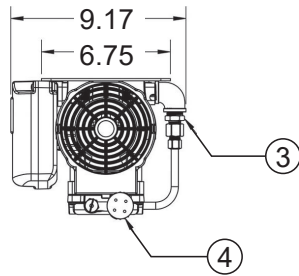

ITEM	PART NUMBER	DESCRIPTION	NO. REQ'D
1	25903	Relief Valve	1
2	19312	Pressure Switch	1
3	19311	Check Valve	1
4	25904	Air Filter	1
5	19309	Mounting Bracket Kit	1

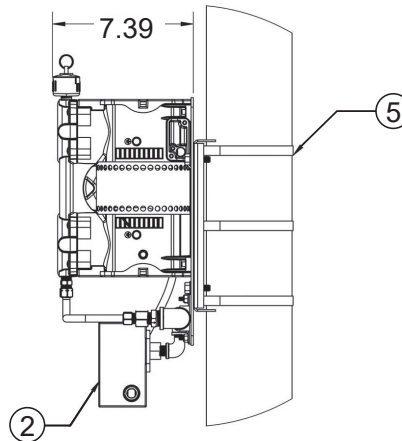
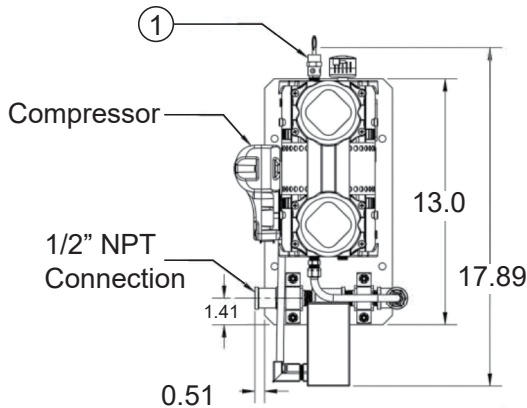

Figure 2 - Replacement Parts

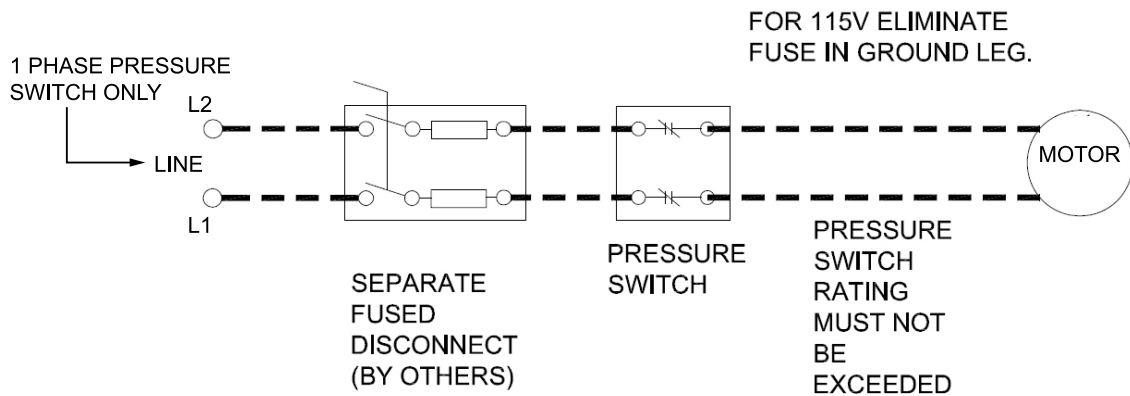

Figure 3 - Pressure Switch Wiring Diagram