



TECHNICAL DATA

RESIDENTIAL SPRINKLER EXTENSIONS

1. DESCRIPTION

Viking residential sprinkler extensions are designed to provide the system designer and installer with a degree of flexibility in pipe placement and sprinkler installation. Available in 1", 1-1/8" and 1-1/4" lengths, the sprinkler extension makes up small amounts of space between the sprinkler and the pipe fitting helping to prevent unnecessary pipe fabrication and ensuring proper sprinkler placement as it relates to the finished ceiling.

2. LISTINGS AND APPROVALS



UL Listed: Category VNTW

For use with listed residential sprinklers with a nominal K-Factor of 5.5 U.S. (79.3 bar) or less only.

For retrofit only. Refer to the residential sprinkler technical data pages for sprinkler listings and approvals.

3. TECHNICAL DATA

Specifications:

Inlet & Outlet - 1/2" NPT

Material Standards:

Brass UNS-C84400

Length of Extension	Part Number
1" (25.4 mm)	14959
1-1/8" (28.6 mm)	14960
1-1/4" (31.8 mm)	14961

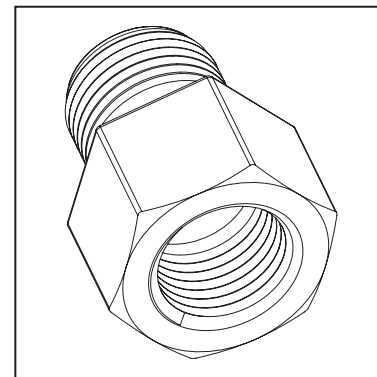

WARNING: Cancer and Reproductive Harm-
www.P65Warnings.ca.gov

Viking Technical Data may be found on
The Viking Corporation's Web site at
<http://www.vikinggroupinc.com>.
The Web site may include a more recent
edition of this Technical Data Page.

Ordering Information: (Also refer to the current Viking price list.)

NOTE: Sprinklers and sprinkler extensions must be ordered separately.

4. INSTALLATION

The extensions come standard with 1/2" threads for connection to the pipe fitting. When installing the extension, apply a small amount of pipe-joint compound or tape to the external threads of the extension only, taking care not to allow a buildup of compound in the extension inlet. Thread the extension into the fitting hand tight. Using a pipe wrench, fully tighten the extension an additional one turn to one and a half turns. Use extreme caution and do not over-tighten into pipe fitting. Carefully review the fitting manufacturer's installation recommendations to ensure compliance. Following the specific sprinkler instructions found on the sprinkler technical data sheet and/or care and handling guides, install the sprinkler into the extension.

5. OPERATION

Refer to the residential sprinkler technical data pages.

6. INSPECTIONS, TESTS AND MAINTENANCE

Refer to NFPA 25 for Inspection, Testing and Maintenance requirements.

7. AVAILABILITY

Viking products are available through a network of domestic and international distributors. See The Viking Corporation web site for the closest distributor or contact The Viking Corporation.

8. GUARANTEE / LIMITED WARRANTY

For details of warranty, refer to Viking's current list price schedule or contact Viking directly.