



TECHNICAL DATA

MODEL VXD SINGLE-INTERLOCKED PREACTION SYSTEM WITH ELECTRIC RELEASE

The Viking Corporation, 210 N Industrial Park Drive, Hastings MI 49058
 Telephone: 269-945-9501 Technical Services: 877-384-5464 Fax: 269-818-1680 Email: techsvcs@vikingcorp.com
 Visit the Viking website for the latest edition of this technical data page www.vikinggroupinc.com

1. INTRODUCTION

Viking supervised VXD Single-Interlocked Preaction Systems utilize a Viking Model VXD Deluge Valve and a pneumatically pressurized automatic sprinkler system. This feature helps prevent undetected leaks. Single-Interlocked Preaction Systems are commonly used where the sprinkler system piping and/or sprinkler may be subject to damage. If the system piping or a sprinkler is damaged, supervisory pressure is reduced and a "low air" supervisory is activated. The electrically controlled preaction systems include an electric solenoid valve controlled by an approved release control panel (sold separately) with compatible detection system (sold separately). In fire conditions, when the detection system operates, the system release control panel energizes the solenoid valve open, causing the deluge valve to open. The sprinkler system fills with water. If any sprinklers have opened, water will flow from the system. If sprinklers have not opened, water will be in the sprinkler system piping when the sprinkler operates. A sprinkler must open before water flows from the system.

2. LISTINGS AND APPROVALS



cULus Listed - Categories VLFT and VLFT7



FM Approved

3. ORDERING INFORMATION

The Model VXD Single Interlock Preaction System with Electric Release is available in Pre-Trimmed Riser (PTR) assembly, Pre-trimmed (PT), or loose configurations with optional accessories to complete the system.

Pre-Trimmed Riser (PTR)

Pre-trimmed riser packages come completely assembled and ready to install. These packages include the Model VXD deluge valve with trim, a riser check valve, additional components as shown below, and come with galvanized pipe and groove/groove connections only.

The Pre-Trimmed Riser packages include the following components:

- Model VXD valve
- Riser check valve
- completely assembled trim
- electric release solenoid
- water supply control valve
- pressure gauges for air and water
- grooved couplings
- water flow and air supervisory pressure switches
- complete drain manifold with hoses and drain cup

**Table 1: Pre-Trimmed Riser (PTR)
 Model VXD Single Interlock Preaction System
 with Electric Release (Vertical)**

Nominal Size (inch)	Part Number	Notes
1½	24887	Pre-Trimmed Riser assemblies include galvanized trim components and grooved pipe connections.
2	24897	
2½	25466	
3	25398	
4	25413	
6	25439	
8	25499	
10	Not available	



WARNING: Cancer and Reproductive Harm-
www.P65Warnings.ca.gov

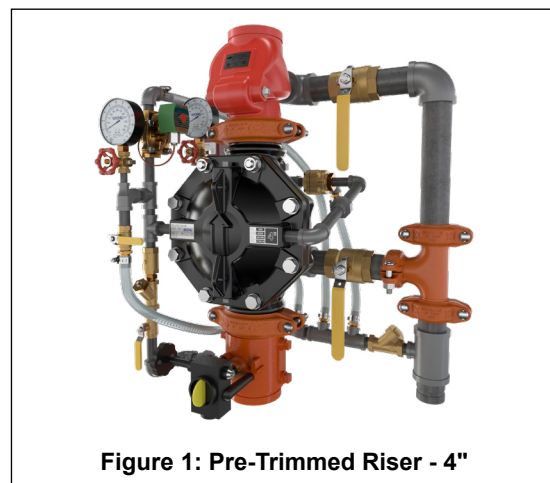

Figure 1: Pre-Trimmed Riser - 4"



TECHNICAL DATA

MODEL VXD SINGLE-INTERLOCKED PREACTION SYSTEM WITH ELECTRIC RELEASE

The Viking Corporation, 210 N Industrial Park Drive, Hastings MI 49058
 Telephone: 269-945-9501 Technical Services: 877-384-5464 Fax: 269-818-1680 Email: techsvcs@vikingcorp.com
 Visit the Viking website for the latest edition of this technical data page www.vikinggroupinc.com

Pre-trimmed (PT) Assemblies

Pre-trimmed packages come completely assembled and ready to install. These packages include the Model VXD valve with trim as shown below, a riser check valve, and come with galvanized pipe and groove/groove connections only.

The Pre-trimmed packages include the following components:

- Model VXD valve
- riser check valve
- completely assembled trim
- electric release solenoid
- pressure gauges for air and water
- loose drain cup

Refer to Table 2 for ordering information.

Loose Trim Packages

NOTICE: The Model VXD valve must be trimmed as shown on the trim diagrams. Any deviation from trim size or arrangement may affect the proper operation of the valve. Refer to the appropriate trim diagram for the system size and type to be used.

Loose trim packages come loose in a box and assembly is required. These packages do NOT include the Model VXD deluge valve or a riser check valve, which must be ordered separately. The Model VXD deluge valve can be ordered with flange/flange or groove/groove connections (refer to the Model VXD deluge valve technical data). The loose trim packages can be ordered with galvanized or brass trim, refer to table 2 below.

These packages include the following components:

- all required trim components
- electric release solenoid
- pressure gauges for air and water
- loose drain cup

Refer to the "System Components" for more information.

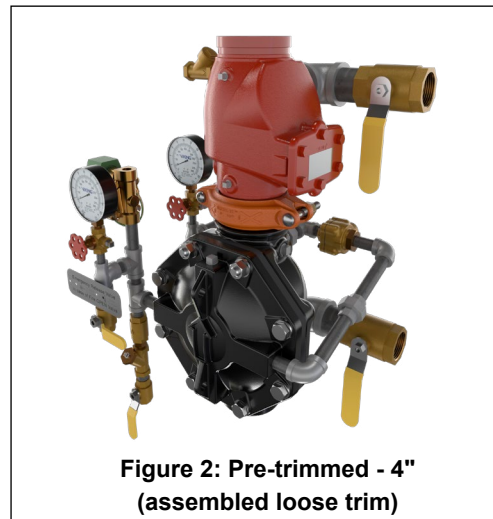

Figure 2: Pre-trimmed - 4"
(assembled loose trim)

Table 2: Pre-trimmed (PT) and Loose trim Model VXD Single Interlock Preaction System with Electric Release (Vertical)

Nominal Size	Ordering Information				Notes
	Pre-trimmed	Loose trim			
	Galvanized	Galvanized	Brass		
1-½	23563	23562-1	23562-2	Loose trim packages do NOT include the VXD valve or the riser check valve. Refer to the Model VXD Deluge valve technical data sheet for more information.	
2	23584	23583-1	23583-2		
2½	23605	23604-1	23604-2		
3	23626	23625-1	23625-2		
4	23647	23646-1	23646-2		
6	23669	23668-1	23668-2		
8	23690	23689-1	23689-2		
10	23751	23750-1	23750-2		



TECHNICAL DATA

MODEL VXD SINGLE-INTERLOCKED PREACTION SYSTEM WITH ELECTRIC RELEASE

The Viking Corporation, 210 N Industrial Park Drive, Hastings MI 49058
 Telephone: 269-945-9501 Technical Services: 877-384-5464 Fax: 269-818-1680 Email: techsvcs@vikingcorp.com
 Visit the Viking website for the latest edition of this technical data page www.vikinggroupinc.com

4. SYSTEM COMPONENTS

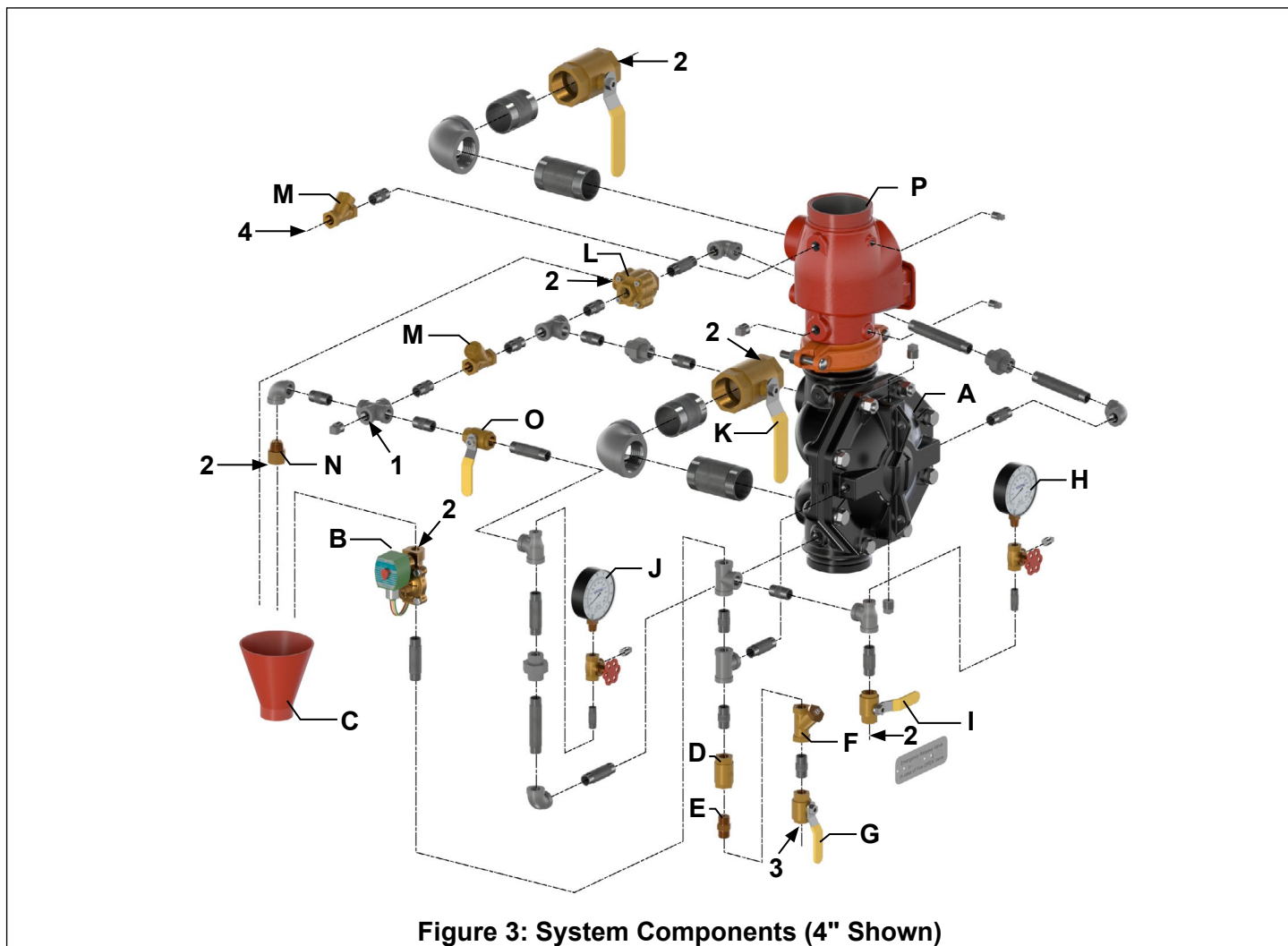

Figure 3: System Components (4" Shown)

Item	Description	Item	Description	Item	Description
A	Deluge valve	I	Emergency release valve (normally closed)	1	Water flow alarm (example: PS-10) connection point (device purchased separately)
B	Solenoid valve	J	Water supply pressure gauge		
C	Drain cup	K	Flow test valve (normally closed)	2	Drain connection point (piping not provided)
D	In-line check valve	L	Pressure Operated Relief Valve (P.O.R.V.)		
E	1/8" Restricted orifice	M	Swing check valve	3	Prime supply connection point (must be piped to upstream of main water supply valve; piping not provided)
F	Y-strainer	N	1/8" Restricted orifice		
G	Priming valve (normally open)	O	Alarm test valve (normally closed)	4	Air supply or Low Air switch (example: PS-40) connection point (devices purchased separately)
H	Prime pressure gauge	P	Riser check valve (with drain trim)		

NOTE: Piping shown for reference only.



TECHNICAL DATA

MODEL VXD SINGLE-INTERLOCKED PREACTION SYSTEM WITH ELECTRIC RELEASE

The Viking Corporation, 210 N Industrial Park Drive, Hastings MI 49058
 Telephone: 269-945-9501 Technical Services: 877-384-5464 Fax: 269-818-1680 Email: techsvcs@vikingcorp.com
 Visit the Viking website for the latest edition of this technical data page www.vikinggroupinc.com

5. SYSTEM OPERATION

5.1 In the SET condition:

System water supply pressure enters the priming chamber of the deluge valve through the priming line, which includes a normally open priming valve (A), strainer (B), restricted orifice (not shown), check valve (C) and also stops at the inlet of the normally closed PORV (D). In the SET condition, water supply pressure is trapped in the priming chamber by check valve (C), normally closed solenoid valve (E), and the emergency release (F). The pressure in the priming chamber holds the Deluge Valve diaphragm closed, keeping the outlet chamber and system piping dry.

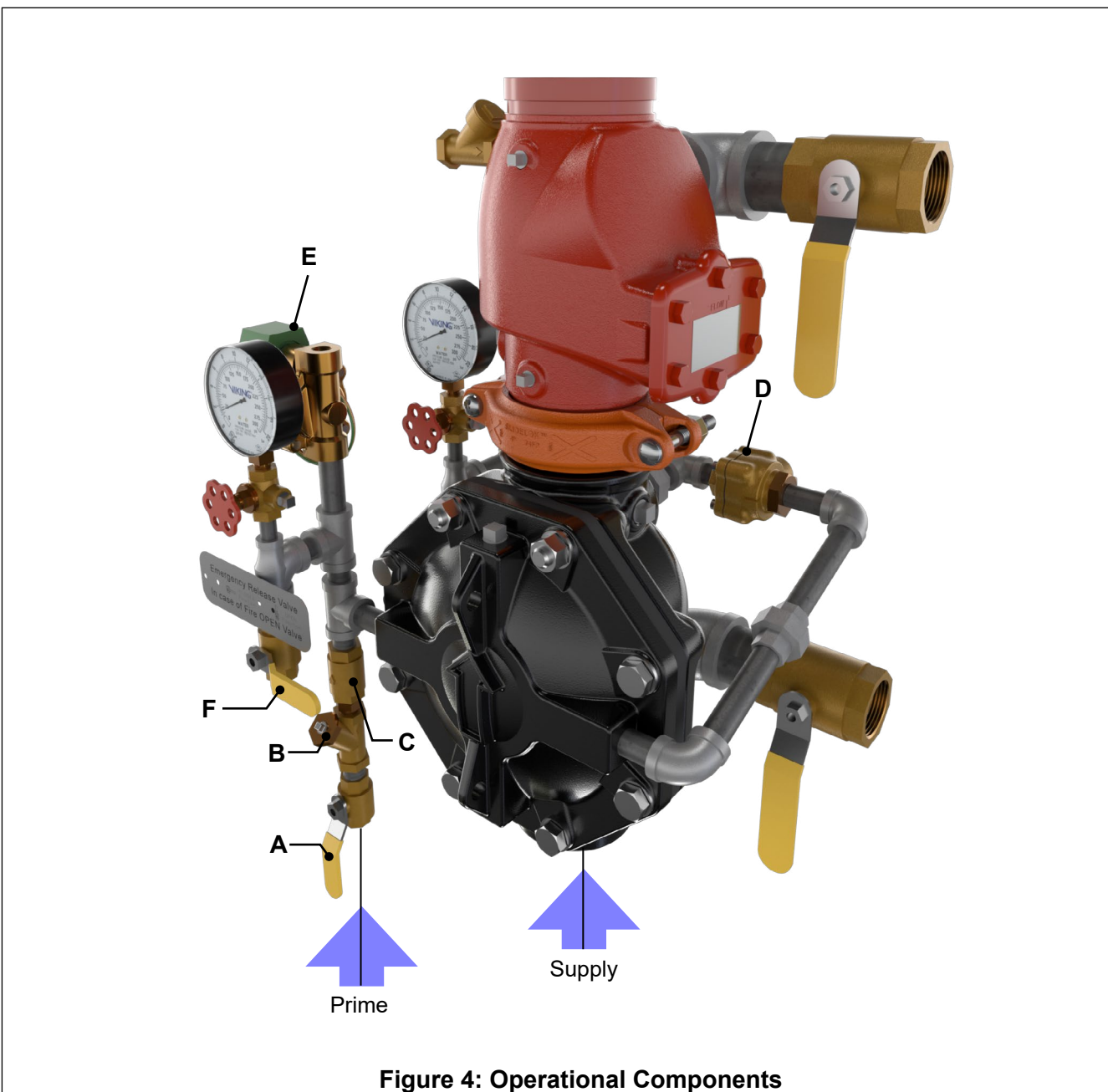

Figure 4: Operational Components



TECHNICAL DATA

MODEL VXD SINGLE-INTERLOCKED PREACTION SYSTEM WITH ELECTRIC RELEASE

The Viking Corporation, 210 N Industrial Park Drive, Hastings MI 49058
 Telephone: 269-945-9501 Technical Services: 877-384-5464 Fax: 269-818-1680 Email: techsvcs@vikingcorp.com
 Visit the Viking website for the latest edition of this technical data page www.vikinggroupinc.com

5.2 In fire conditions:

When the detection system operates, the system release control panel activates an alarm and energizes the normally closed solenoid valve (E) open. Pressure is released from the priming chamber faster than it is supplied through the restricted orifice. The Deluge Valve diaphragm opens to allow water to flow into the system piping and alarm devices, causing the water motor alarm and/or water flow alarms connected to the alarm pressure switch (not shown) to activate. Water will flow from any open sprinklers and/or spray nozzles on the system. When the deluge valve operates, water is drained from the PORV inlet. When the 10:1 differential is overcome, the push rod opens, allowing the prime water to drain. If a release resets, priming water will continue to escape through the PORV, allowing the deluge valve to continue to operate until the system is reset. The Deluge Valve can only be reset after the system is taken out of service, and the outlet chamber of the deluge valve and associated trim piping are de-pressurized and drained.

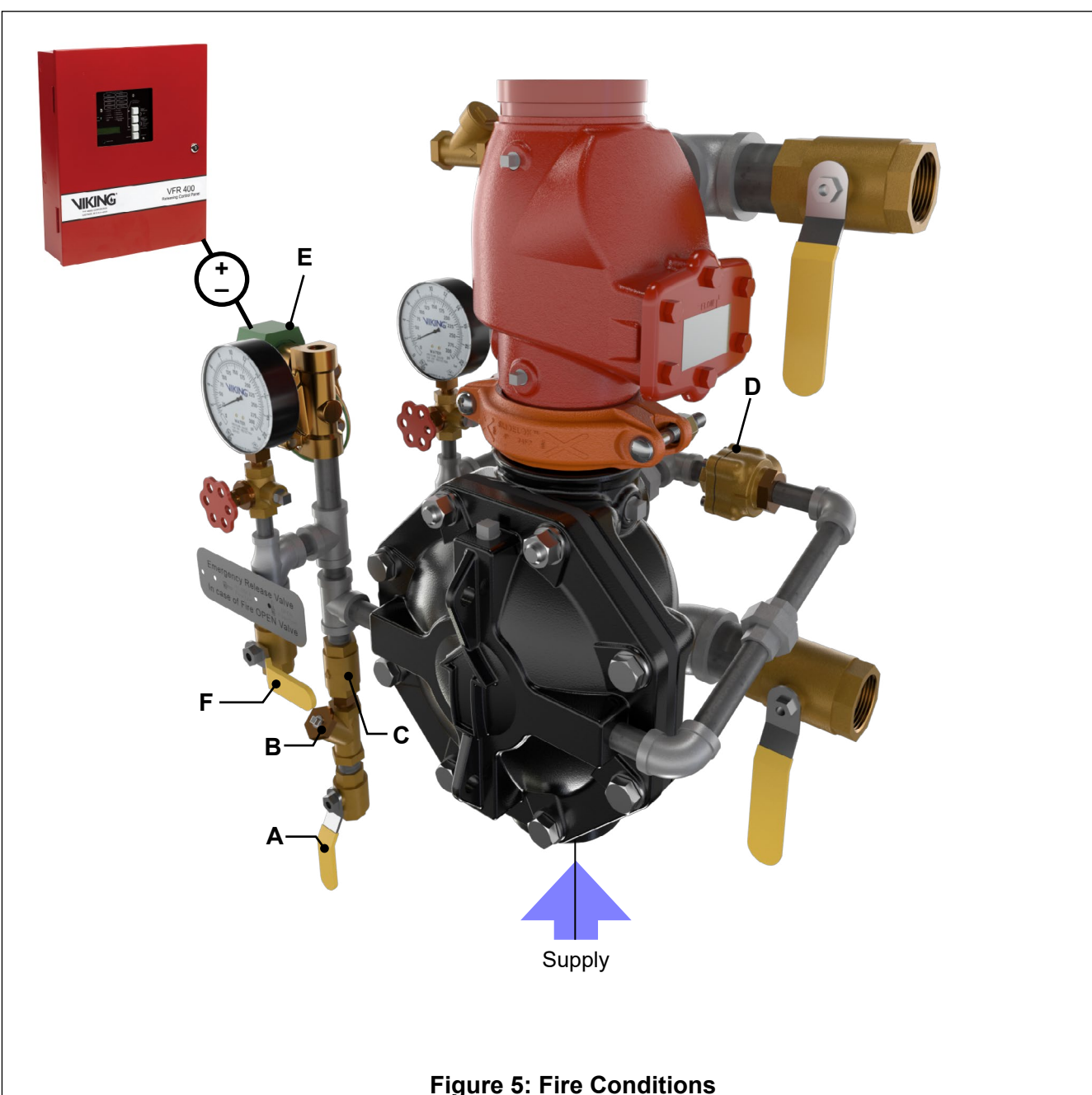

Figure 5: Fire Conditions



TECHNICAL DATA

MODEL VXD SINGLE- INTERLOCKED PREACTION SYSTEM WITH ELECTRIC RELEASE

The Viking Corporation, 210 N Industrial Park Drive, Hastings MI 49058
 Telephone: 269-945-9501 Technical Services: 877-384-5464 Fax: 269-818-1680 Email: techsvcs@vikingcorp.com
 Visit the Viking website for the latest edition of this technical data page www.vikinggroupinc.com

5.3 In trouble conditions:

If a sprinkler opens prior to operation of the detection system, or any time supervisory pressure in the sprinkler piping is lost, the air supervisory switch will signal a low air pressure condition, but the deluge valve will NOT open. If the detection system operates due to mechanical damage or malfunction, the deluge valve will open, but the water will be contained in the sprinkler piping. The water motor alarm and alarms connected to the alarm pressure switch will activate.

5.4 Manual operation:

Anytime the emergency release is pulled, pressure is released from the priming chamber and the deluge valve will open. Water will flow into the system piping and alarm devices. Water will flow from any open sprinklers and/or spray nozzles on the system.

6. INSTALLATION

Refer to current Viking Technical Data describing individual components of the Viking VXD Deluge System. Also, refer to applicable installation standards, codes, and Authorities Having Jurisdiction.

6.1 Important Settings

1. Recommended supervisory pressure in the closed sprinkler piping is 20 PSI (1.4 bar):
 - a. Where supervisory pressure is maintained at 20 PSI (1.4 bar), set the air supervisory switch to activate at 15 PSI (1.03 bar) on pressure drop.
 - b. The air supervisory switch should be wired to activate a supervisory alarm to signal a "low air" pressure condition. Activation of an alarm to signal a high pressure condition may be required. Refer to applicable installation standards and the Authority Having Jurisdiction.

NOTE: Installation Standards may allow supervisory pressures lower than those recommended above. When using supervisory pressures lower than the recommended setting noted above, verify that the air regulation equipment and air supervisory switches used are compatible with the supervisory pressure setting used.

2. Alarm pressure switch should activate when pressurized to 4 to 8 PSI (.3 to .6 bar) on pressure rise. Alarm pressure switch should be wired to activate the water flow alarm.

6.2 Air Supply Design

The air supply compressor should be sized to establish total required air pressure in 30 minutes. The air supply must be regulated, restricted, and maintained automatically. The air maintenance device is used to regulate and restrict the flow of supervisory air into the sprinkler system piping.

The air supply must be regulated to maintain the pressure desired in the release system. Pressure settings other than those recommended in section 6.1 above may affect operation of the system. The air supply must be restricted to ensure that the automatic air supply cannot replace air as fast as it escapes when a releasing device operates.

Riser Mounted Air Compressors:

A riser mounted air compressor may be suitable for small electrically operated single-interlocked preaction systems; however, placement of a dehydrator and/or an air maintenance device in the outlet piping of a riser mounted air compressor may affect operation of the compressor.



TECHNICAL DATA

MODEL VXD SINGLE-INTERLOCKED PREACTION SYSTEM WITH ELECTRIC RELEASE

The Viking Corporation, 210 N Industrial Park Drive, Hastings MI 49058
 Telephone: 269-945-9501 Technical Services: 877-384-5464 Fax: 269-818-1680 Email: techsvcs@vikingcorp.com
 Visit the Viking website for the latest edition of this technical data page www.vikinggroupinc.com

7. PLACING THE SYSTEM IN SERVICE

Placing the Valve in Service:

1. Verify the following:
 - The system main water supply control valve (not shown) is closed.
 - The system has been properly drained and main drain (J) is open.
 - The emergency release (F) is closed.
2. Close the system main drain (J).
3. Restore supervisory pressure to the sprinkler piping. Verify that the 1/2" valve in the air maintenance device by-pass trim is closed and that both the 1/4" valves are open.
4. Establish a normal condition on the release control panel.
5. Open the priming valve (A).
6. Open flow test valve (G).
7. Slowly and partially open main water supply control valve (not shown).

NOTE: Opening the main water supply valve too quickly can create excessive pressure causing the valve to trip.
8. When full flow develops from the flow test valve (G), close the valve. Verify that there is no flow from the open orifice.
9. Fully open and secure the main water supply control valve.
10. Verify that all valves are in their normal operating position.
11. Verify that no water is discharging into the drain cup.
12. Check for, and repair all leaks.
13. On new installations, those systems that have been placed out of service, or where new equipment has been installed, trip test the system to verify that all equipment functions properly. Refer to Annual Trip Tests, section 9.2.C.
14. After completing a trip test, perform semi-annual maintenance. Refer to section 9.3.B.

CAUTION

Performing a trip test results in operation of the Deluge Valve. Water will flow into the sprinkler piping. Take necessary precautions to prevent damage.

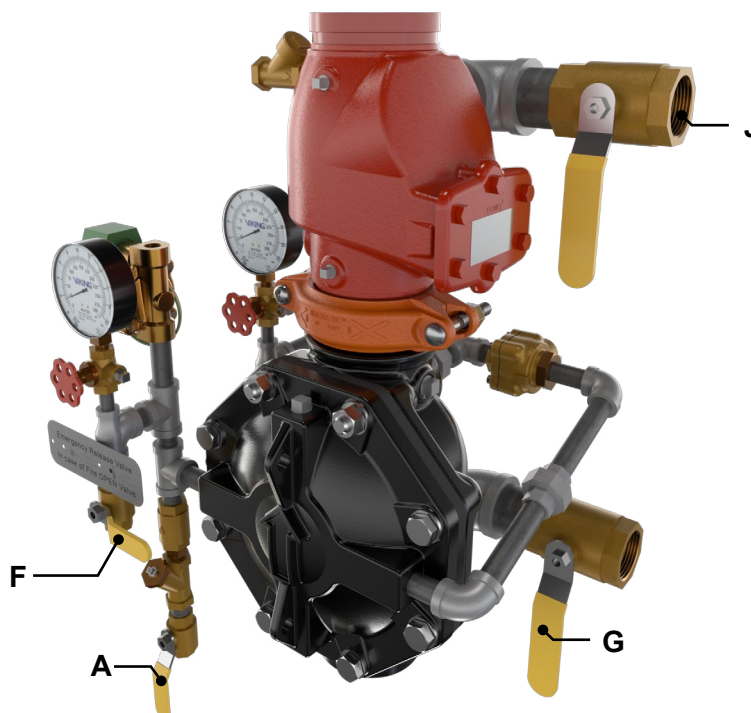

Figure 6: Placing the System in Service



TECHNICAL DATA

MODEL VXD SINGLE- INTERLOCKED PREACTION SYSTEM WITH ELECTRIC RELEASE

The Viking Corporation, 210 N Industrial Park Drive, Hastings MI 49058
 Telephone: 269-945-9501 Technical Services: 877-384-5464 Fax: 269-818-1680 Email: techsvcs@vikingcorp.com
 Visit the Viking website for the latest edition of this technical data page www.vikinggroupinc.com

8. EMERGENCY INSTRUCTIONS

⚠ WARNING

WARNING: Placing a control valve or detection system out of service may eliminate the fire protection capabilities of the system. Prior to proceeding, notify all Authorities Having Jurisdiction (AHJ). Consideration should be given to employment of a fire patrol in the affected areas.

Refer to the appropriate technical data page and NFPA standards for complete care, handling, installation, and maintenance instructions. For additional product and system information, Viking data pages and installation instructions are available on the Viking Web site at www.vikinggroupinc.com.

To take system out of service (Refer to Figure 6):

After a fire, verify that the fire is OUT and that placing the system out of service has been authorized by the appropriate Authority Having Jurisdiction.

1. Close the water supply control valve (not shown).
NOTE: Sprinkler systems that have been subjected to a fire must be returned to service as soon as possible. The entire system must be inspected for damage, and repaired or replaced as necessary.
2. Close the priming valve (A).
3. Replace any release devices, sprinklers and/or spray nozzles that have been damaged or have been exposed to fire conditions.
4. Perform all maintenance procedures recommended in Technical Data describing individual components of the system that have operated.
5. Return the system to service as soon as possible. Refer to section 7: Placing the System In Service.

9. INSPECTIONS, TESTS, AND MAINTENANCE

⚠ WARNING

Any system maintenance that involves placing a control valve or detection system out of service may eliminate the fire protection capabilities of that system. Prior to proceeding, notify all Authorities Having Jurisdiction. Consideration should be given to employment of a fire patrol in the affected areas.

NOTICE

The owner is responsible for maintaining the fire protection system and devices in proper operating condition.

It is imperative that the system be inspected and tested on a regular basis in accordance with NFPA 25. Refer to current Viking Technical Data describing individual components.

The frequency of the inspections may vary due to contaminated water supplies, corrosive water supplies, corrosive atmospheres, as well as the condition of the air supply to the system. For minimum maintenance and inspection requirements, refer to NFPA 25. In addition, the Authority Having Jurisdiction may have additional maintenance, testing, and inspection requirements that must be followed.

9.1 Inspection

Weekly - Viking recommends a weekly visual inspection; check the following items.

- Verify that the main water supply control valve is open and that all other valves are in their normal operating position and appropriately secured. (refer to Figure 3)
- Check for signs of mechanical damage, leakage, and/or corrosive activity. If detected, perform maintenance as required. If necessary, replace the device.
- Verify that the valve and trim are adequately heated and protected from freezing and physical damage.

NOTE: For normal operating position, refer to Figure 3.



TECHNICAL DATA

MODEL VXD SINGLE- INTERLOCKED PREACTION SYSTEM WITH ELECTRIC RELEASE

The Viking Corporation, 210 N Industrial Park Drive, Hastings MI 49058
 Telephone: 269-945-9501 Technical Services: 877-384-5464 Fax: 269-818-1680 Email: techsvcs@vikingcorp.com
 Visit the Viking website for the latest edition of this technical data page www.vikinggroupinc.com

9.2 Periodic System Tests

A. Quarterly Water Flow Alarm Test

1. Notify the Authority Having Jurisdiction and those in the area affected by the test.
2. To test the local electric alarm (if provided) and/or mechanical water motor alarm (if provided), OPEN the alarm test valve in the Deluge Valve trim.
 - a. Electric alarm pressure switches (if provided) should activate.
 - b. Electric local alarms should be audible.
 - c. The local water motor gong should be audible.
 - d. If equipped with remote station alarm signaling devices, verify that alarm signals were received.
3. When testing is complete, CLOSE the Alarm Test Valve.
4. Verify the following:
 - a. All local alarms stop sounding and alarm panels (if provided) reset.
 - b. All remote station alarms reset.
 - c. Supply piping to water motor alarm properly drains.
5. Verify that the Alarm Test Valve is CLOSED.
6. Verify that the outlet chamber is free of water. No water should flow from the alarm drain line.
7. Notify the Authority Having Jurisdiction and those in the affected area that testing is complete.

B. Quarterly Main Drain Test

1. Notify the Authority Having Jurisdiction and those in the area affected by the test.
2. Record pressure reading from the water supply pressure gauge.
3. Verify that the outlet chamber of the Deluge Valve is free of water. No water should flow from the alarm drain line.
4. Fully OPEN the Flow Test Valve.
5. When a full flow is developed from the Flow Test Valve, record the residual pressure from the water supply pressure gauge.
6. When the test is complete, SLOWLY CLOSE the Flow Test Valve.
7. Compare test results with previous flow information. If deterioration of the water supply is detected, take appropriate steps to restore adequate water supply.
8. Verify:
 - a. Normal water supply pressure has been restored to the inlet chamber, the priming chamber, and the release system. The pressure on the priming chamber water pressure gauge should equal the system water supply pressure.
 - b. All alarm devices and valves are secured in normal operating position (refer to Figure 3).
9. Notify the Authority Having Jurisdiction that the test is complete. Record and/or provide notification of test results as required by the Authority Having Jurisdiction.

C. Annual Trip Test

CAUTION

Performing this test results in operation of the Deluge Valve. Water will flow into the sprinkler piping and from any open sprinklers and/or nozzles. Take necessary precautions to prevent damage.

1. Notify the Authority Having Jurisdiction and those in the area affected by the test.
2. Fully open the Flow Test Valve to flush away any accumulation of foreign material.
3. Close the Flow Test Valve.
4. Trip the system by operating a detector. Allow a full flow to pass through the Deluge Valve. Water flow alarms should operate.
5. When test is complete:
 - a. Close the Main Water Supply Control Valve.
 - b. Close the Priming Valve.
 - c. Open all system main drains. Allow the system to drain completely.
6. Perform semi-annual maintenance. Refer to section 9.3.B: Semi-Annual Maintenance.
7. Place the system in service. Refer to section: "7. Placing the System in Service".
8. Notify the Authority Having Jurisdiction that the test is complete. Record and/or provide notification of test results as required by the Authority Having Jurisdiction.



TECHNICAL DATA

MODEL VXD SINGLE- INTERLOCKED PREACTION SYSTEM WITH ELECTRIC RELEASE

The Viking Corporation, 210 N Industrial Park Drive, Hastings MI 49058
 Telephone: 269-945-9501 Technical Services: 877-384-5464 Fax: 269-818-1680 Email: techsvcs@vikingcorp.com
 Visit the Viking website for the latest edition of this technical data page www.vikinggroupinc.com

D. Quarterly "Low Air" Pressure Alarm Test

IMPORTANT

Do not operate the electric detection system during this test.

1. Notify the Authority Having Jurisdiction and those in the area affected by the test.
2. Close the main water supply valve.
NOTE: Closing the main water supply valve prevents operation of the deluge valve during the test.
3. Fully open the sprinkler system's test connection.
4. Verify that the low air alarms operate within an acceptable time period and continue without interruption.
5. Establish recommended pneumatic supervisory pressure to be maintained. Refer to section "6.1 Important Settings".
6. Reset the system release control panel to stop the alarms.
7. Return the system to service. Refer to section: "7. Placing the System in Service".

9.3 Maintenance

A. After Each Operation:

1. Sprinkler systems that have been subjected to a fire must be returned to service as soon as possible. The entire system must be inspected for damage, and repaired or replaced as necessary.
2. Deluge Valves and trim that have been subjected to brackish water, salt water, foam/water solution, or any other corrosive water supply, should be flushed with good quality fresh water before being returned to service.
3. Perform semi-annual maintenance after every operation.

B. Semi-Annually:

1. Remove the system from service.
2. Close the Main Water Supply Control Valve and Priming Valve.
3. Relieve pressure in the priming chamber by opening the emergency release Valve.
4. Inspect all trim for signs of corrosion and/or blockage. Clean and/or replace as required.
5. Clean and/or replace all strainer screens.
6. Refer to section: "7. Placing the System in Service".

C. Every Fifth Year:

1. Internal inspection of Deluge Valves is recommended every five years unless inspections and tests indicate more frequent internal inspections are required. Refer to the Model VXD Valve Technical Data Page.
2. Internal inspection of strainers, and restricted orifices is recommended every five years unless inspections and tests indicate more frequent internal inspections are required.
3. Record and provide notification of inspection results as required by the Authority Having Jurisdiction.



TECHNICAL DATA

MODEL VXD SINGLE-INTERLOCKED PREACTION SYSTEM WITH ELECTRIC RELEASE

The Viking Corporation, 210 N Industrial Park Drive, Hastings MI 49058
 Telephone: 269-945-9501 Technical Services: 877-384-5464 Fax: 269-818-1680 Email: techsvcs@vikingcorp.com
 Visit the Viking website for the latest edition of this technical data page www.vikinggroupinc.com

10. DIMENSIONS

10.1 Dimensions - Pre-Trimmed and Assembled Loose Packages

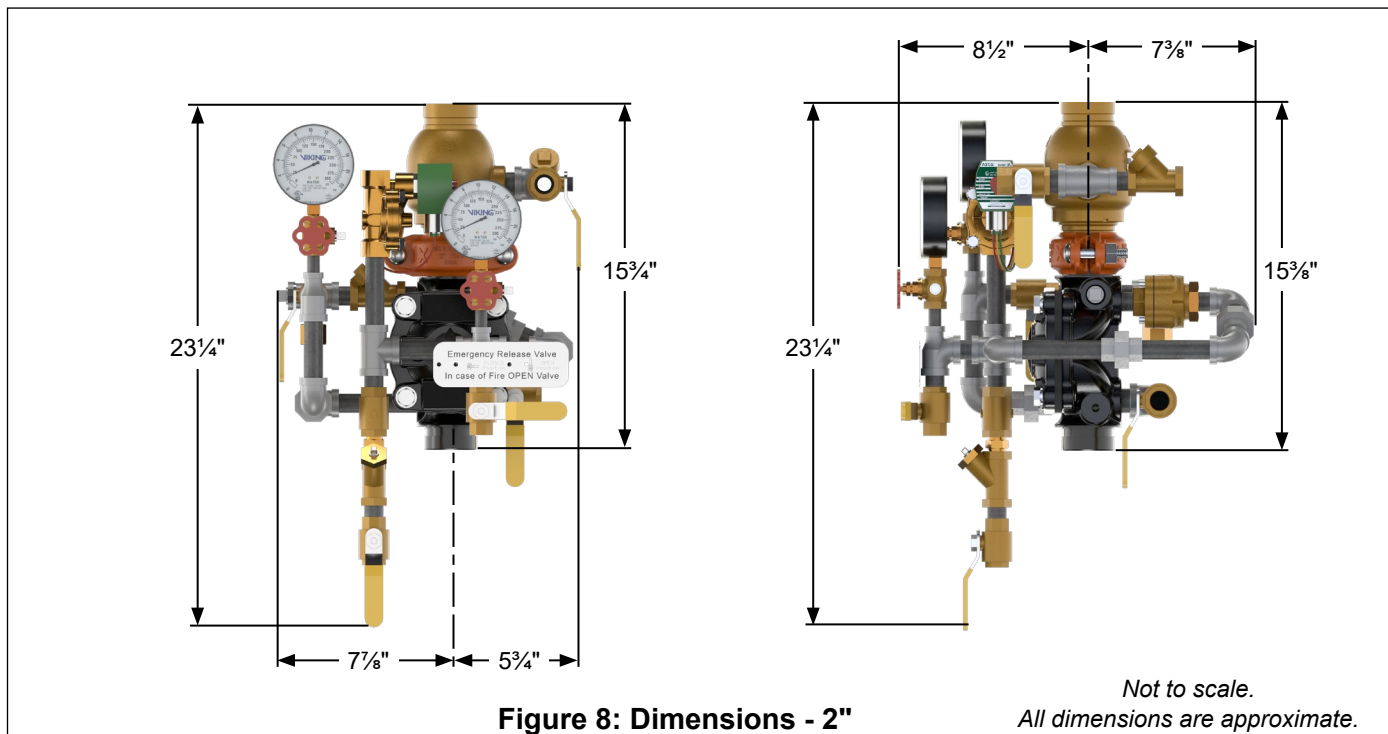
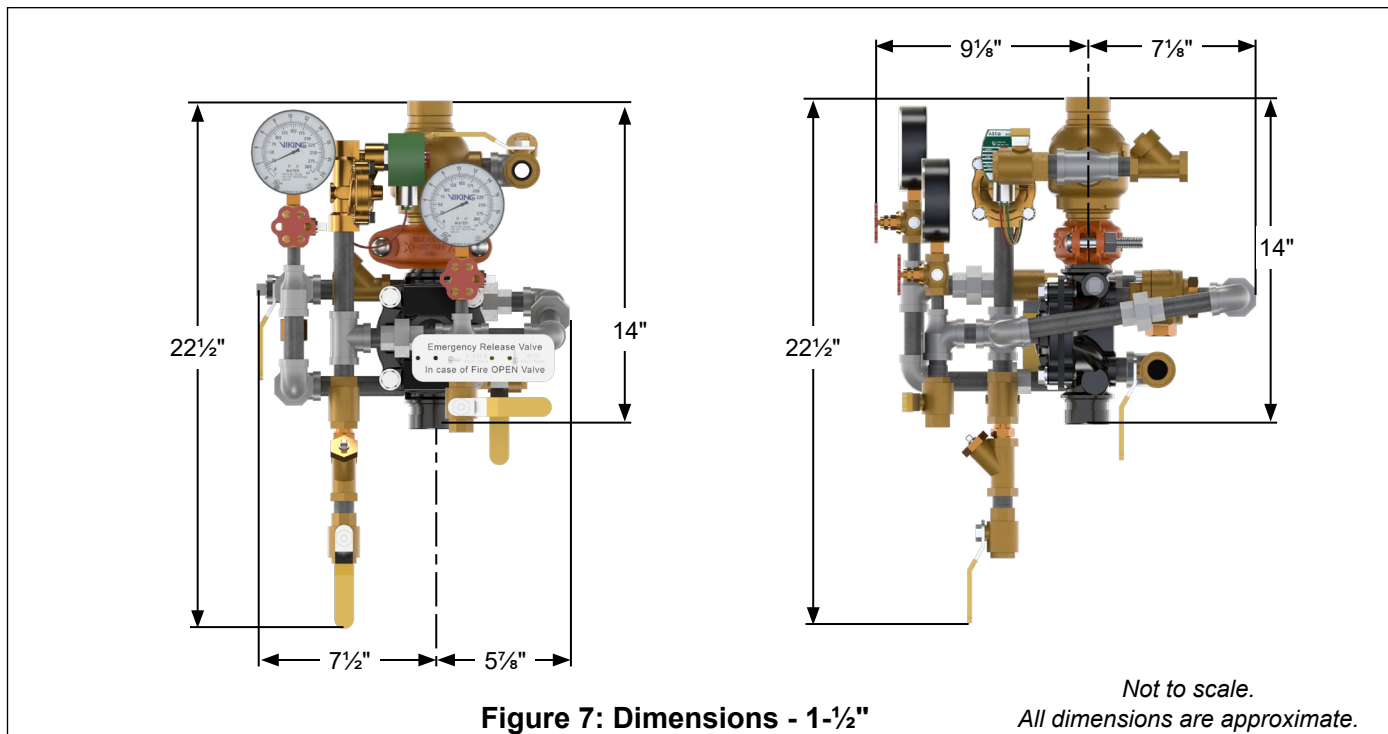



TECHNICAL DATA

MODEL VXD SINGLE-INTERLOCKED PREACTION SYSTEM WITH ELECTRIC RELEASE

The Viking Corporation, 210 N Industrial Park Drive, Hastings MI 49058
 Telephone: 269-945-9501 Technical Services: 877-384-5464 Fax: 269-818-1680 Email: techsvcs@vikingcorp.com
 Visit the Viking website for the latest edition of this technical data page www.vikinggroupinc.com

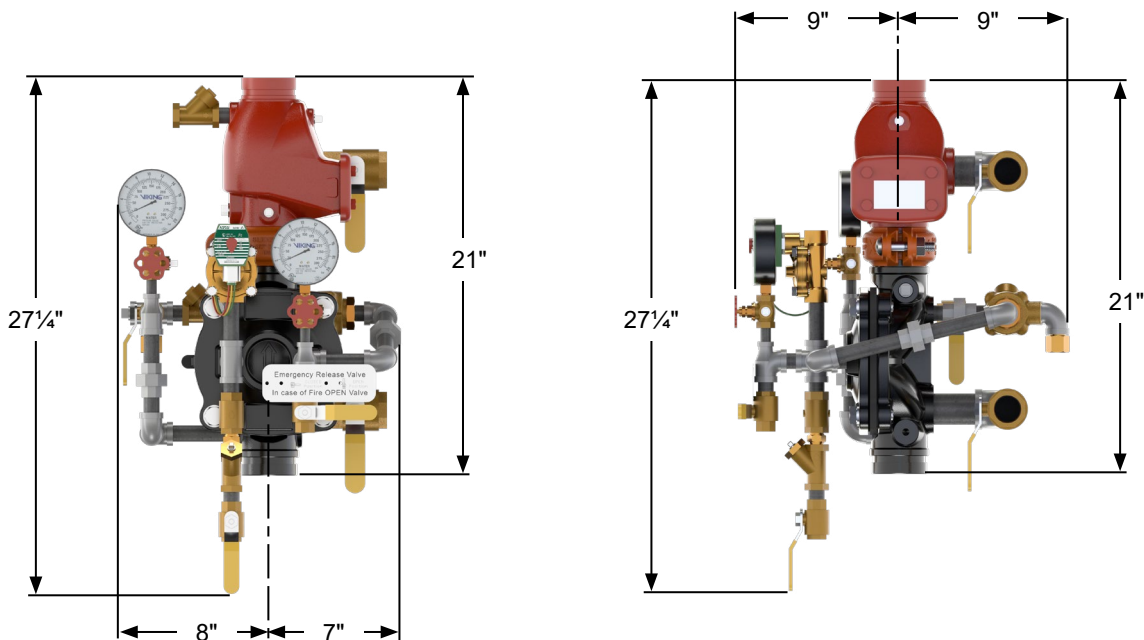

Figure 9: Dimensions - 2 1/2"

*Not to scale.
 All dimensions are approximate.*

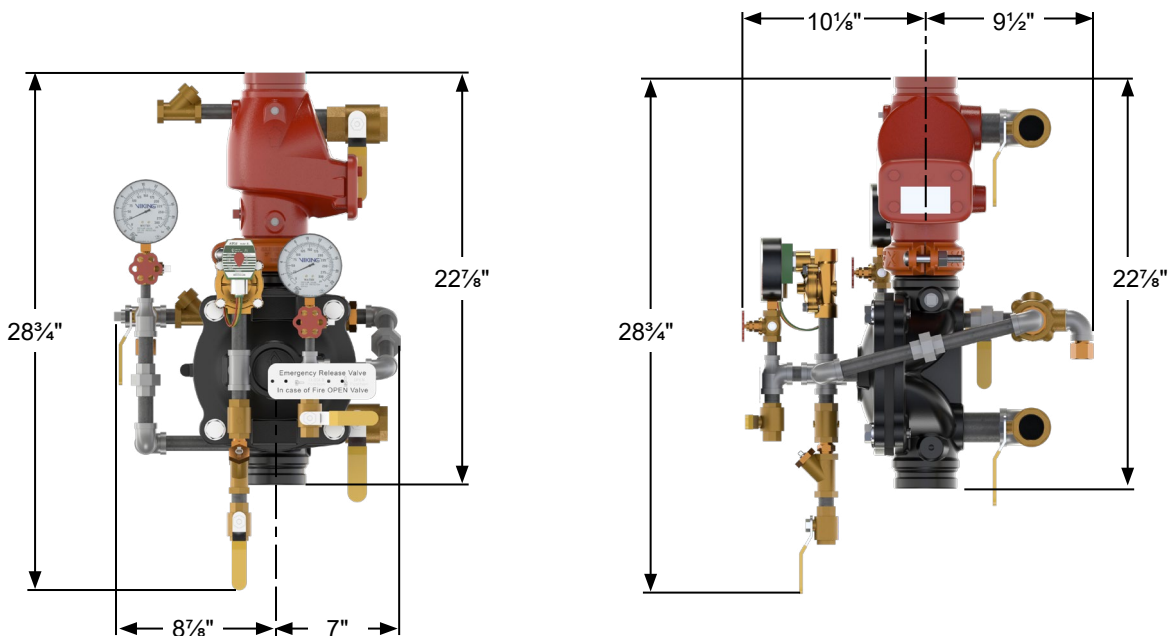

Figure 10: Dimensions - 3"

*Not to scale.
 All dimensions are approximate.*



TECHNICAL DATA

MODEL VXD SINGLE-INTERLOCKED PREACTION SYSTEM WITH ELECTRIC RELEASE

The Viking Corporation, 210 N Industrial Park Drive, Hastings MI 49058
 Telephone: 269-945-9501 Technical Services: 877-384-5464 Fax: 269-818-1680 Email: techsvcs@vikingcorp.com
 Visit the Viking website for the latest edition of this technical data page www.vikinggroupinc.com

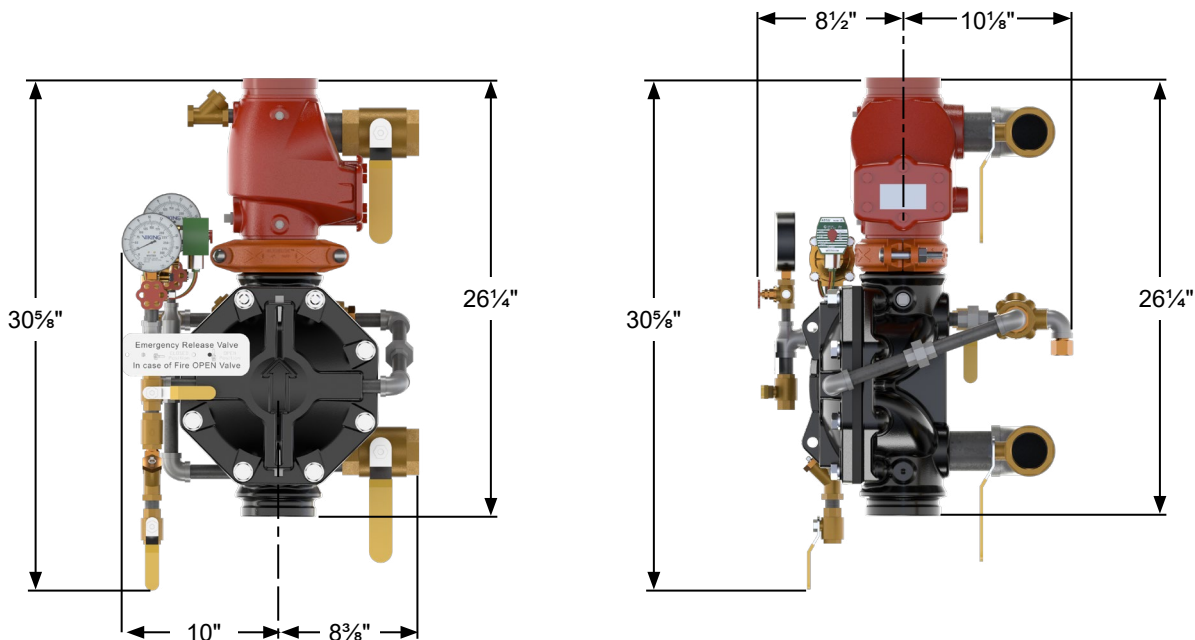

Figure 11: Dimensions - 4"

*Not to scale.
 All dimensions are approximate.*

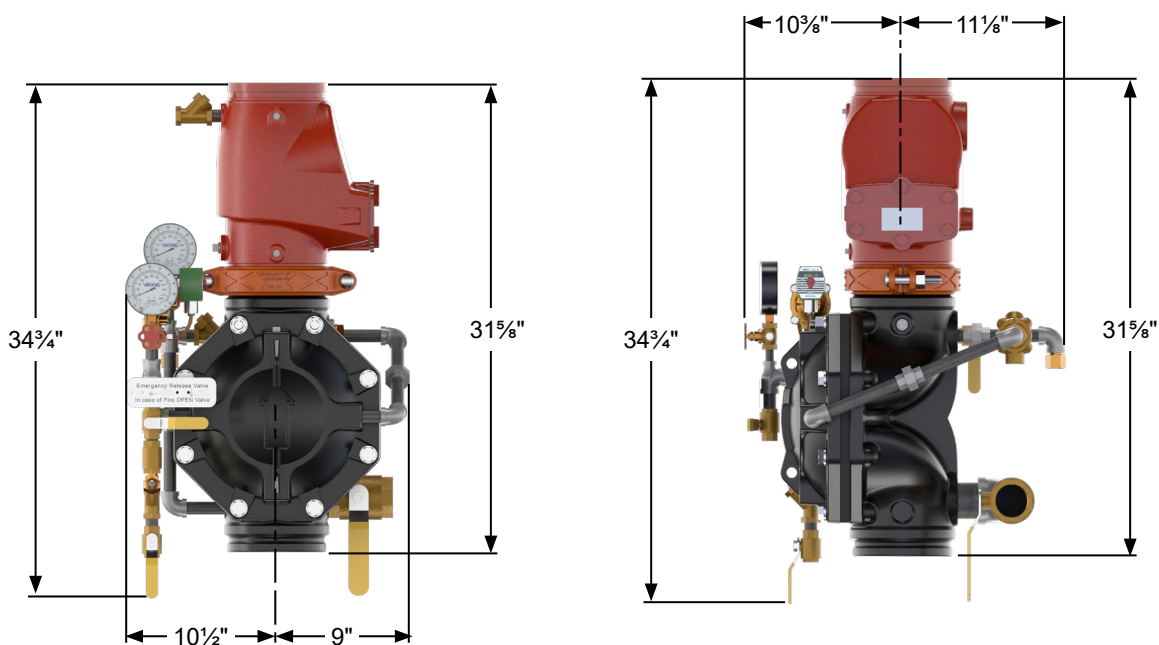

Figure 12: Dimensions - 6"

*Not to scale.
 All dimensions are approximate.*



TECHNICAL DATA

MODEL VXD SINGLE-INTERLOCKED PREACTION SYSTEM WITH ELECTRIC RELEASE

The Viking Corporation, 210 N Industrial Park Drive, Hastings MI 49058
 Telephone: 269-945-9501 Technical Services: 877-384-5464 Fax: 269-818-1680 Email: techsvcs@vikingcorp.com
 Visit the Viking website for the latest edition of this technical data page www.vikinggroupinc.com

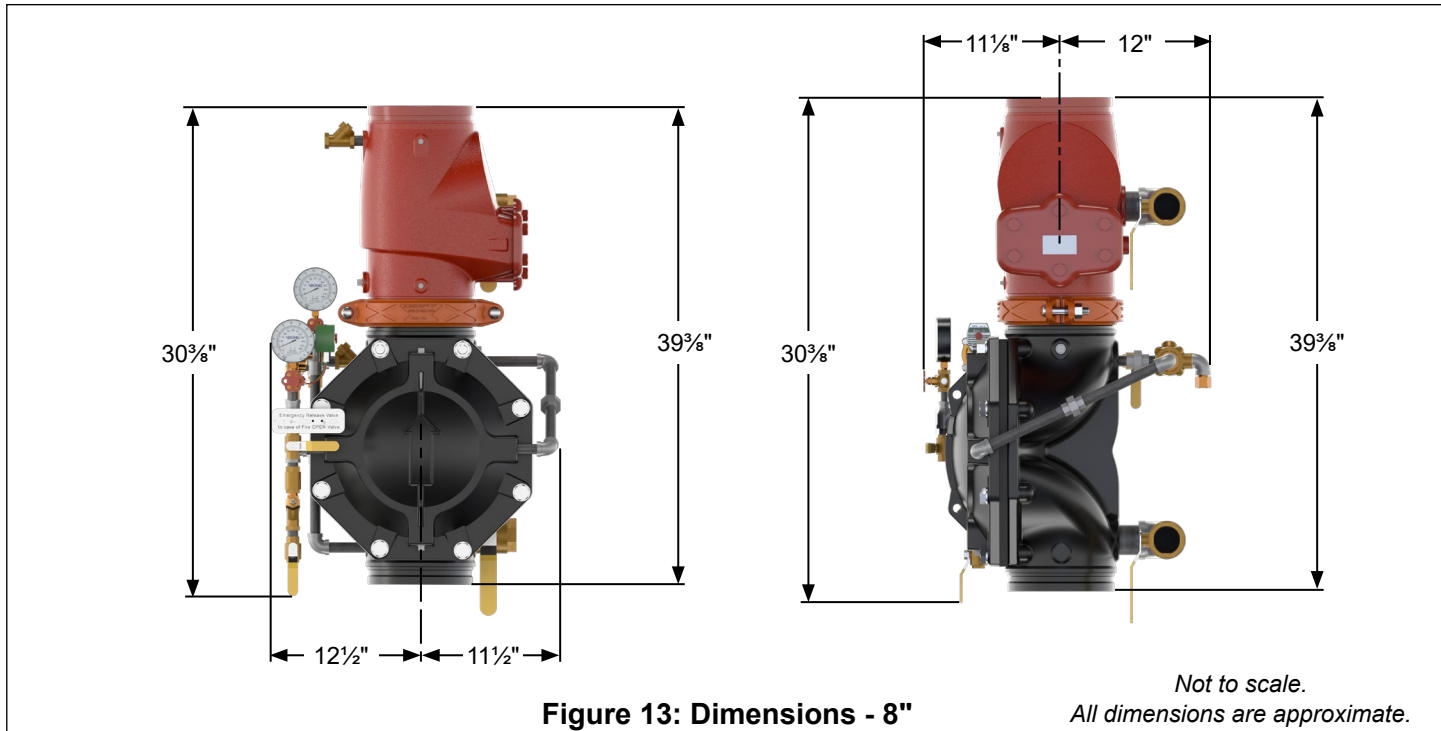

Figure 13: Dimensions - 8"

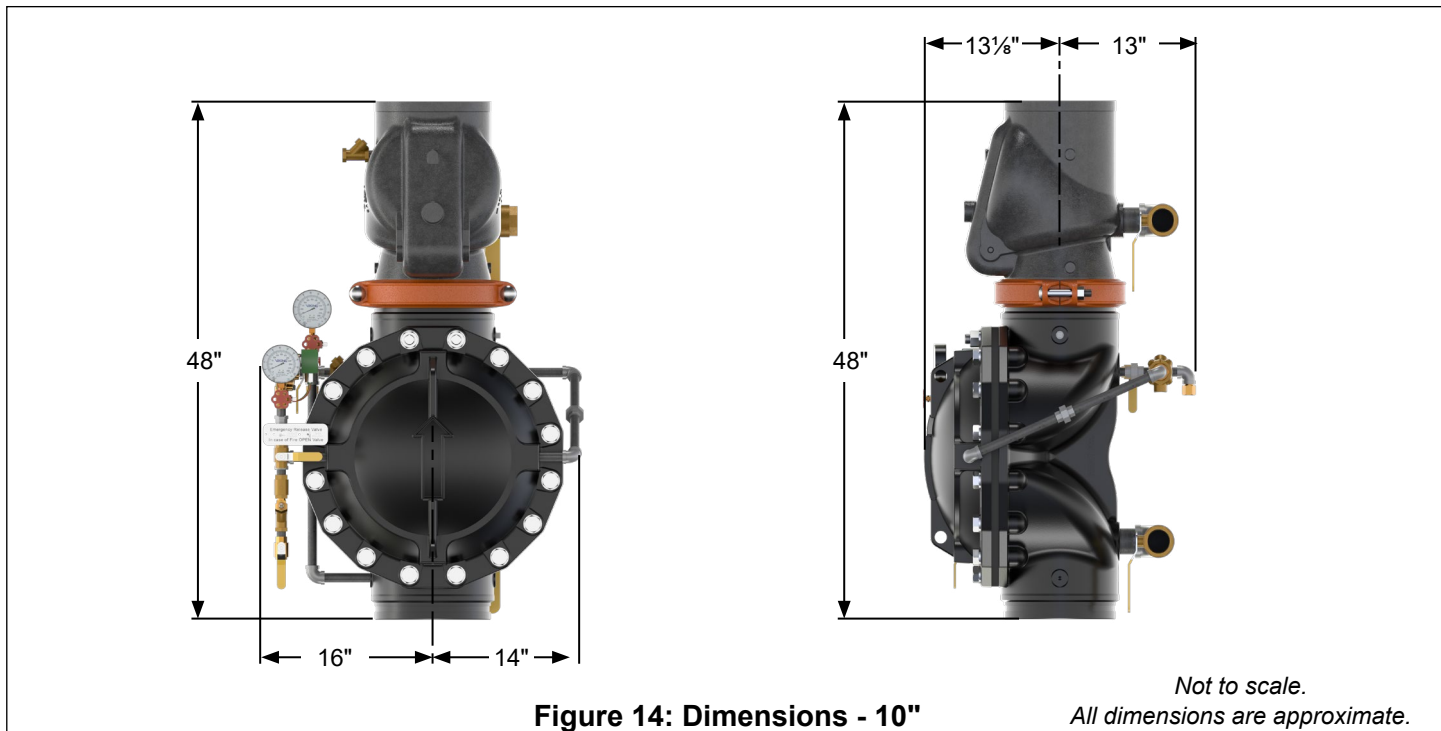

Figure 14: Dimensions - 10"