



TECHNICAL DATA

FREEDOM® RESIDENTIAL UPRIGHT LEAD FREE SPRINKLER VK4670 (K4.9)

The Viking Corporation, 210 N Industrial Park Drive, Hastings MI 49058
 Telephone: 269-945-9501 Technical Services: 877-384-5464 Fax: 269-818-1680 Email: techsvcs@vikingcorp.com
 Visit the Viking website for the latest edition of this technical data page: www.vikinggroupinc.com

1. DESCRIPTION

Viking Freedom® Residential Upright Lead Free* Sprinkler VK4670 is a small, thermosensitive, glass-bulb residential sprinkler available in several different finishes and temperature ratings to meet varying design requirements. The orifice design, with a K-Factor of 4.9 (70.6 metric†), allows efficient use of available water supplies for the hydraulically designed fire-protection system. The glass bulb operating element and special deflector characteristics meet the challenges of residential sprinkler standards.

* Lead content complies with the definition of 'Lead Free' established in the Reduction of Lead in Drinking Water Act (S.3874) endorsed by AWWA's Water Utility Council, and California Assembly Bill #1953.

2. LISTINGS AND APPROVALS



UL Listed (C-UL-US-EU): Category VKKW

UL Classified to: NSF/ANSI/CAN Standard 61, Drinking Water System Components and NSF/ANSI 372 (MH48034). Refer to the Approval Chart Design Criteria for C-UL-US-EU Listing requirements that must be followed.



WARNING: Cancer and Reproductive Harm-
www.P65Warnings.ca.gov

3. TECHNICAL DATA

Specifications:

Minimum Operating Pressure: Refer to the Approval Chart.

Maximum Working Pressure: 175 psi (12 bar). Factory tested hydrostatically to 500 psi (34.5 bar).

Thread size: 1/2" (15 mm) NPT

Nominal K-Factor: 4.9 U.S. (70.6 metric†)

†Metric K-factor measurement shown is in Bar. When pressure is measured in kPa, divide the metric K-factor shown by 10.0.

Glass-bulb fluid temperature rated to -65 °F (-55 °C)

Overall Length: 2-1/4" (58 mm)

Material Standards:

Frame Casting: Brass UNS-C89833

Deflector: Brass UNS-C23000 or Bronze UNS-C22000

Bulb: Glass, nominal 3 mm diameter

Belleville Spring Sealing Assembly: Nickel Alloy, coated on both sides with Polytetrafluoroethylene (PTFE) Tape

Pip Cap and Insert Assembly: Copper UNS-C11000 and Stainless Steel UNS-S30400

Compression Screw: Brass UNS-C36000

Ordering Information: (Refer to the current Viking price list.)

4. INSTALLATION

Refer to appropriate NFPA Installation Standards.

5. OPERATION

During fire conditions, the heat-sensitive liquid in the glass bulb expands, causing the glass to shatter, releasing the pip cap and sealing spring assembly. Water flowing through the sprinkler orifice strikes the sprinkler deflector, forming a uniform spray pattern to extinguish or control the fire.

6. INSPECTIONS, TESTS AND MAINTENANCE

Refer to NFPA 25 for Inspection, Testing and Maintenance requirements.

7. AVAILABILITY

The Viking Freedom® Residential Upright Lead Free Sprinkler VK4670 is available through a network of domestic and international distributors. See The Viking Corporation web site for the closest distributor or contact The Viking Corporation.

8. GUARANTEE

For details of warranty, refer to Viking's current list price schedule or contact Viking directly.



TECHNICAL DATA

FREEDOM® RESIDENTIAL UPRIGHT LEAD FREE SPRINKLER VK4670 (K4.9)

The Viking Corporation, 210 N Industrial Park Drive, Hastings MI 49058
 Telephone: 269-945-9501 Technical Services: 877-384-5464 Fax: 269-818-1680 Email: techsvcs@vikingcorp.com
 Visit the Viking website for the latest edition of this technical data page: www.vikinggroupinc.com

TABLE 1: ORDERING INFORMATION

Instructions: Using the sprinkler base part number,
 (1) add the suffix for the desired Finish
 (2) add the suffix for the desired Temperature Rating.

Sprinkler Base Part No.	Size		1: Finishes		2: Temperature Ratings			
	NPT Inch	BSP mm	Description	Suffix ¹	Nominal Rating	Bulb Color	Max. Ambient Ceiling Temperature ³	Suffix
19442	1/2	--	Brass	A	155 °F (68 °C)	Red	100 °F (38 °C)	B
			Chrome	F	175 °F (79 °C)	Yellow	150 °F (65 °C)	D
			White Polyester ^{4,5}	M-/W				
			Black Polyester ^{4,5}	M-/B				

Example: 19442AB = VK4670 with Brass Finish and 155 °F (68 °C) Nominal temperature rating. This sprinkler is to be installed into an area with a maximum ambient temperature of 100 °F (38 °C) meaning if the area will experience temperatures above the maximum ambient rating, you shall use a higher temperature-rated sprinkler.

Accessories

Sprinkler Wrenches (see Figure 1):

A. Standard Wrench: Part No. 21475M/B (available since 2017).

Sprinkler Cabinet:

A. Up to 6 sprinklers: Part number 01724A (available since 1971).

B. 6-12 Sprinklers: Part number 01725A (available since 1971).

Footnotes

- Where a dash (-) is shown in the Finish suffix designation, insert the desired Temperature Rating suffix. See example above.
- Requires a 1/2" ratchet which is not available from Viking.
- Based on NFPA 13, NFPA 13R, and NFPA 13D. Other limits may apply, depending on fire loading, sprinkler location, and other requirements of the Authority Having Jurisdiction. Refer to specific installation standards.
- UL Listed as corrosion resistant.
- The corrosion resistant coatings have passed the standard corrosion test required by the approving agencies indicated in the Approval Chart. These tests cannot and do not represent all possible corrosive environments. Prior to installation, verify through the end-user that the coatings are compatible with or suitable for the proposed environment.
- Allows installation from the floor by attaching a length of 1" diameter CPVC tubing to the tool. Ideal for sprinkler cabinets. Refer to Bulletin F_051808.

	TECHNICAL DATA	FREEDOM® RESIDENTIAL UPRIGHT LEAD FREE SPRINKLER VK4670 (K4.9)
---	-----------------------	---

The Viking Corporation, 210 N Industrial Park Drive, Hastings MI 49058
 Telephone: 269-945-9501 Technical Services: 877-384-5464 Fax: 269-818-1680 Email: techsvcs@vikingcorp.com
 Visit the Viking website for the latest edition of this technical data page: www.vikinggroupinc.com

TABLE 2: AVAILABLE SPRINKLER TEMPERATURE RATINGS AND FINISHES			
Sprinkler Temperature Classification	Sprinkler Nominal Temperature Rating ¹	Maximum Ambient Ceiling Temperature ²	Bulb Color
Ordinary	155 °F (68 °C)	100 °F (38 °C)	Red
Intermediate	175 °F (79 °C)	150 °F (65 °C)	Yellow
Sprinkler Finishes: Brass, Chrome, White Polyester, and Black Polyester			
Footnotes			
¹ The sprinkler temperature rating is stamped on the deflector. ² Based on NFPA-13. Other limits may apply, depending on fire loading, sprinkler location, and other requirements of the Authority Having Jurisdiction. Refer to specific installation standards.			

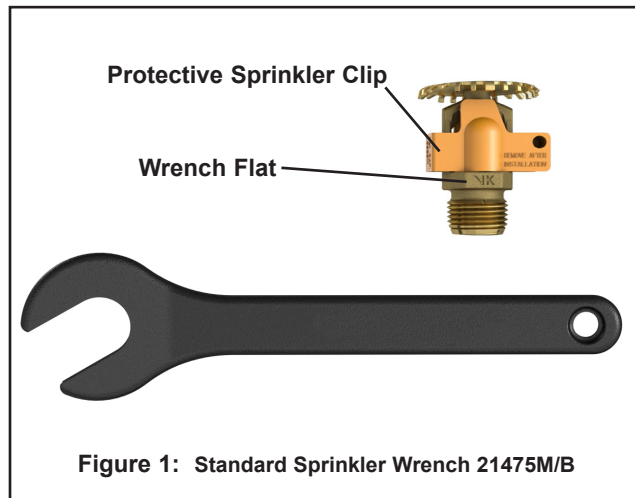



TECHNICAL DATA

FREEDOM® RESIDENTIAL UPRIGHT LEAD FREE SPRINKLER VK4670 (K4.9)

The Viking Corporation, 210 N Industrial Park Drive, Hastings MI 49058
 Telephone: 269-945-9501 Technical Services: 877-384-5464 Fax: 269-818-1680 Email: techsvcs@vikingcorp.com
 Visit the Viking website for the latest edition of this technical data page: www.vikinggroupinc.com

Approval Chart Viking VK4670, 4.9 K-Factor Residential Upright Sprinkler

For systems designed to NFPA 13D or NFPA 13R. For systems designed to NFPA 13, refer to the design criteria. For Ceiling types refer to the most current Edition of NFPA 13, 13R or 13D

Sprinkler Base Part Number ¹	SIN	NPT Thread Size		Nominal K-Factor		Maximum Water Working Pressure	Overall Length			
		Inches	mm	U.S.	metric ²		Inches	mm		
19442	VK4670	1/2	15	4.9	70.6	175 psi (12 bar)	2-1/4	58		
Max. Coverage Area ⁴ Ft.X Ft. (m X m)	Ordinary Temp Rating (155 °F/68 °C)		Intermediate Temp Rating (175 °F/79 °C)		Deflector to Ceiling	Installation Type	Listings and Approvals ³			Minimum Spacing Ft. (m)
	Flow ⁴ GPM (L/min)	Pressure ⁴ PSI (bar)	Flow ⁴ GPM (L/min)	Pressure ⁴ PSI (bar)			 ⁵	NYC	NSF ⁸	
12 X 12 (3.7 X 3.7)	14 (53.0)	8.16 (0.56)	14 (53.0)	8.16 (0.56)	3 - 5 inches	Upright	See Foot-note 7.	See Foot-note 6.	See Foot-note 7.	9 (2.74)
14 X 14 (4.3 X 4.3)	14 (53.0)	8.16 (0.56)	14 (53.0)	8.16 (0.56)						
16 X 16 (4.9 X 4.9)	16 (60.6)	10.66 (0.73)	16 (60.6)	10.66 (0.73)						
12 X 12 (3.7 X 3.7)	15 (56.8)	9.37 (0.65)	15 (56.8)	9.37 (0.65)	5 - 10 inches					
14 X 14 (4.3 X 4.3)	15 (56.8)	9.37 (0.65)	15 (56.8)	9.37 (0.65)						
16 X 16 (4.9 X 4.9)	18 (68.1)	13.49 (0.93)	18 (68.1)	13.49 (0.93)						
12 X 12 (3.7 X 3.7)	15 (56.8)	9.37 (0.65)	--	--	1 to 3 inches below 14 inch beams					
14 X 14 (4.3 X 4.3)	15 (56.8)	9.37 (0.65)	--	--						
16 X 16 (4.9 X 4.9)	18 (68.1)	13.49 (0.93)	--	--						

Footnotes

- ¹ Part number shown is the base part number. For complete part number, refer to Viking's current price schedule.
- ² Metric K-factor measurement shown is when pressure is measured in Bar. When pressure is measured in kPa, divide the metric K-factor shown by 10.0.
- ³ This chart shows the listings and approvals available at the time of printing. Other approvals may be in process. Check with the manufacturer for any additional approvals. Refer also to Design Criteria.
- ⁴ For areas of coverage smaller than shown, use the "Flow" and "Pressure" for the next larger area listed. Flows and pressures listed are per sprinkler. The distance from sprinklers to walls shall not exceed one-half the sprinkler spacing indicated for the minimum "Flow" and "Pressure" used.
- ⁵ Listed by Underwriter's Laboratories, Inc. for use in the U.S., Canada, and European Union.
- ⁶ Meets New York City requirements, effective July 1, 2008.
- ⁷ Approved Finishes are: Brass, Chrome, White Polyester, and Black Polyester⁹
- ⁸ UL Classified to: NSF/ANSI/CAN Standard 61, Drinking Water System Components and NSF/ANSI 372 (MH48034).
- ⁹ Other paint colors are available on request with the same C-UL-US-EU listings as the standard finish colors.



TECHNICAL DATA

FREEDOM® RESIDENTIAL UPRIGHT LEAD FREE SPRINKLER VK4670 (K4.9)

The Viking Corporation, 210 N Industrial Park Drive, Hastings MI 49058
 Telephone: 269-945-9501 Technical Services: 877-384-5464 Fax: 269-818-1680 Email: techsvcs@vikingcorp.com
 Visit the Viking website for the latest edition of this technical data page: www.vikinggroupinc.com

DESIGN CRITERIA

(Also refer to the Approval Chart.)

UL Listing Requirements (C-UL-US-EU):

When using Viking Freedom® Residential Upright Lead Free Sprinkler VK4670 for systems designed to NFPA 13D or NFPA 13R, apply the listed areas of coverage and minimum water supply requirements shown in the Approval Chart.

For systems designed to NFPA 13: The number of design sprinklers is to be the four contiguous most hydraulically demanding sprinklers. The minimum required discharge from each of the four sprinklers is to be the greater of the following:

- The flow rates given in the Approval Chart for NFPA 13D and NFPA13R applications for each listed area of coverage, or
- Calculated based on a minimum discharge of 0.1 gpm/sq. ft. over the “design area;” refer to the latest edition of NFPA 13.
- Minimum distance between residential sprinklers: 9 ft. (2.74 m).

BEAM CEILING GUIDELINES

C-UL-US-EU Listed for installation in residential occupancies with beam ceilings (with horizontal ceilings only).

Refer to the Approval Chart for sprinkler areas of coverage and hydraulic design.

Sprinkler Location: Locate sprinklers on the underside of the beams (not in the bays or pockets formed by the beams). Refer to Figure 2. The vertical distance from the sprinkler deflector to the bottom of the primary beam must be between 1” and 3” (25 to 76 mm). The horizontal distance from the centerline of the sprinkler to the primary beam cannot be more than 2” (51 mm) (Figure 2).

Beam Position: Directly attached to the underside of a combustible or non-combustible smooth ceiling of any height.

Beam Size and Shape (Cross section):

- Depth: Maximum 14” (356 mm) for primary beams. Secondary beam depth cannot be greater than the primary beam.
- Width: Unlimited.
- Beam Shape: Rectangular to circular.

Beam Types: Combustible or non-combustible, solid surface, solid or hollow core.

Beam Spacing:

- A. For primary beams, the distance from the wall to the center of the nearest primary beam must be at least 3'-4" (1.0 m), and not more than one-half the listed sprinkler spacing. **Note:** Sprinklers may not be required to be located in the first beam nearest the wall. Center-to-center distance between primary beams is to be a maximum of 16 ft (4.9 m). Refer to Figure 3A.
- B. When beam pockets created by the primary beams exceed 20 ft (6.1 m) in length, secondary beams are required as follows (also refer to Figure 3B):
 1. Secondary beam depth must be equal to primary beam depth.
 2. Secondary beams must be placed so that the bays formed by the primary beams do not exceed 20 ft (6.1 m) in length.
- C. When primary beam spans do not exceed 20 ft (6.1 m), secondary beams (not required) may have any distance from wall to nearest secondary beam and any distance center to center between secondary beams. Refer to Figure 3C.

Also:

When primary beam spans exceed 20ft (6.1m) an alternate protection scheme for the compartment would be to calculate all the sprinklers in the compartment. Refer to Figure 5.

- More stringent design requirement.
- Secondary beams or baffles would not be required for a compartment space design.
- The minimum required discharge from each sprinkler would utilize flow rates given in the Approval Chart for NFPA 13D and NFPA13R applications

Lintels: Must be present over doorways exiting the compartment. Lintel height must be at least 8” (203 mm), or at least the depth of the primary beams, whichever is greater.

Beam and Soffit Arrangements: If a soffit is installed, beams may be arranged within the soffit. The cross section of the soffit may be any size, provided it does not create an obstruction to water distribution per the obstruction rules of NFPA 13 for residential sprinklers. Where there is a soffit, beam spacing from the wall is to be measured from the face of the soffit rather than the wall. Refer to Figure 3D. **NOTE:** The sprinkler area of coverage is to be measured from the wall.

Definitions:

- Primary beams: The main beams that run primarily in one direction.
- Secondary beams: The beams that run perpendicular to the main beams.

IMPORTANT: Always refer to Bulletin Form No. F_091699 - Care and Handling of Sprinklers. Also refer to Form No.s F_080190, F_080814, and F_080415 for general care, installation, and maintenance information. Viking sprinklers are to be installed in accordance with the latest edition of Viking technical data, the appropriate standards of NFPA and any other similar Authorities Having Jurisdiction, and also with the provisions of governmental codes, ordinances, and standards, whenever applicable. Final approval and acceptance of all residential sprinkler installations must be obtained from the Authorities Having Jurisdiction.



TECHNICAL DATA

**FREEDOM® RESIDENTIAL
UPRIGHT LEAD FREE
SPRINKLER
VK4670 (K4.9)**

The Viking Corporation, 210 N Industrial Park Drive, Hastings MI 49058
Telephone: 269-945-9501 Technical Services: 877-384-5464 Fax: 269-818-1680 Email: techsvcs@vikingcorp.com
Visit the Viking website for the latest edition of this technical data page: www.vikinggroupinc.com

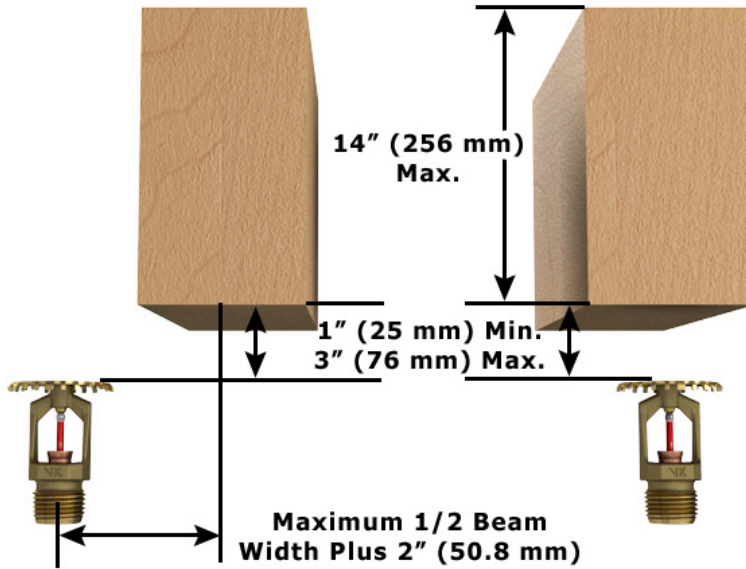

Figure 2: Sprinkler Positioning Under Primary Beams

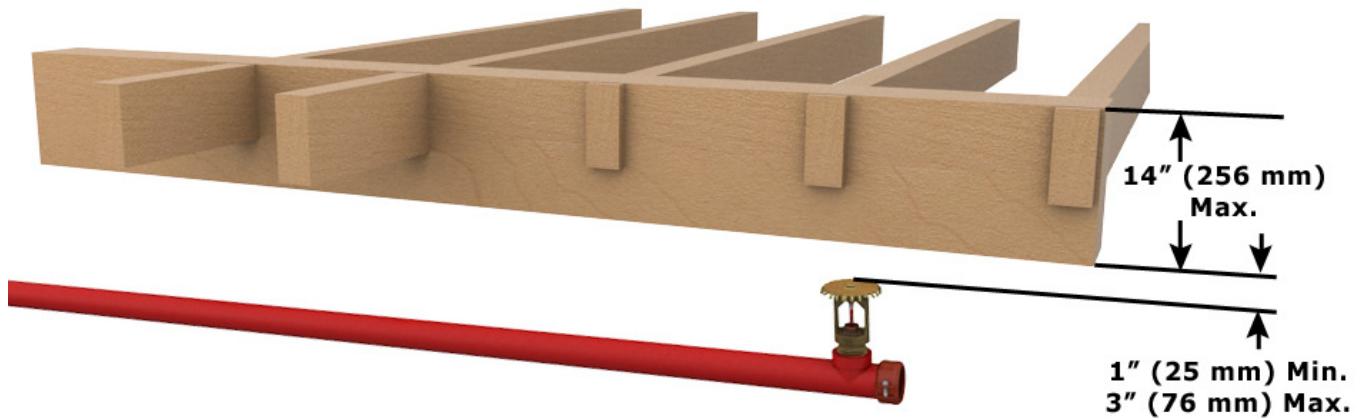

Figure 3: Sprinkler Positioning Under Primary Beams



TECHNICAL DATA

FREEDOM® RESIDENTIAL UPRIGHT LEAD FREE SPRINKLER VK4670 (K4.9)

The Viking Corporation, 210 N Industrial Park Drive, Hastings MI 49058
 Telephone: 269-945-9501 Technical Services: 877-384-5464 Fax: 269-818-1680 Email: techsvcs@vikingcorp.com
 Visit the Viking website for the latest edition of this technical data page: www.vikinggroupinc.com

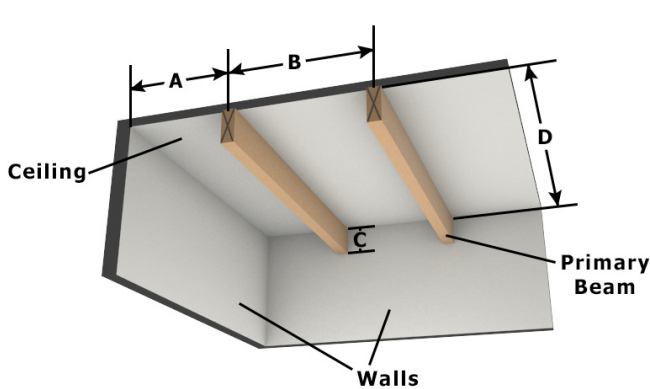

All dimensions are measured to wall faces and to centerlines of beams.

- A = Distance from wall to nearest primary beam:
 Minimum: 3 ft 4 in (1.0 m).
 Maximum: No more than 1/2 listed sprinkler spacing.
- B = Spacing between primary beams: 16 ft (4.9 m) maximum
- C = Beam depth: 14" (356 mm) maximum
- D = Beam span: 20 ft (6.1 m) maximum

Figure 4A: Primary Beam Spans up to 20 ft (6.1 m)

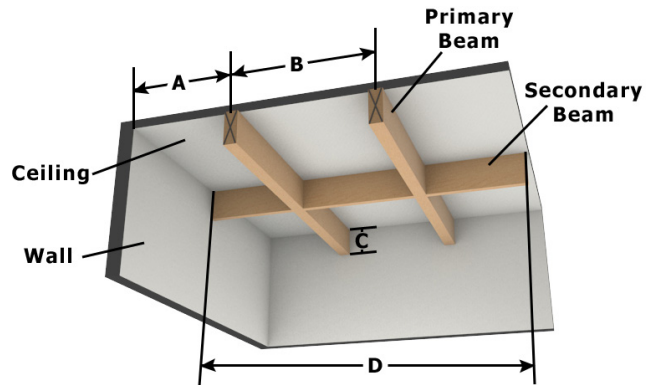

All dimensions are measured to wall faces and to centerlines of beams.

- A = Distance from wall to nearest primary beam:
 Minimum: 3 ft 4 in (1.0 m).
 Maximum: No more than 1/2 listed sprinkler spacing.
- B = Spacing between primary beams: 16 ft (4.9 m) maximum
- C = Beam depth: 14" (356 mm) maximum
- D = 20 ft (6.1 m) maximum for secondary beams that are to be equal in depth for primary beams and that are required so that primary beam pockets do not exceed 20 ft (6.1 m).

Figure 4B: Primary Beam Spans over 20 ft (6.1 m)

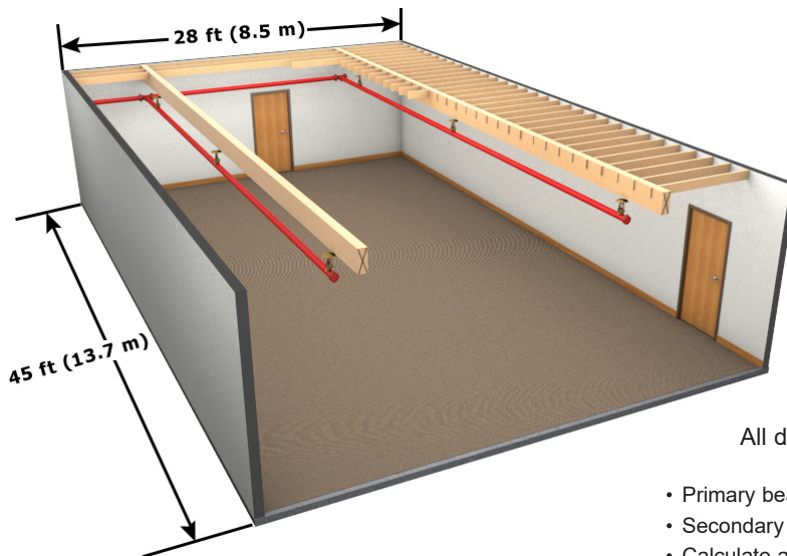

EXAMPLE

All dimensions are measured to wall faces and to centerlines of beams.

- Primary beam spans exceeding 20 ft (6.1 m)
- Secondary beams or baffles not required
- Calculate all sprinklers in compartment
 (Above example 6 sprinklers)

Figure 5: Alternate Entire Compartment Protection Scheme Example



BULLETIN

CARE AND HANDLING
OF SPRINKLERS

The Viking Corporation, 210 N Industrial Park Drive, Hastings MI 49058
 Telephone: 269-945-9501 Technical Services: 877-384-5464 Fax: 269-818-1680 Email: techsvcs@vikingcorp.com

SPRINKLERS ARE FRAGILE - HANDLE WITH CARE!

General Handling and Storage:

- Store sprinklers in a cool, dry place.
- Protect sprinklers during storage, transport, handling, and after installation.
- Use the original shipping containers. DO NOT place sprinklers loose in boxes, bins, or buckets.
- Keep sprinklers separated at all times. DO NOT allow metal parts to contact sprinkler operating elements.

For Pre-Assembled Drops:

- Protect sprinklers during handling and after installation.
- For recessed assemblies, use the protective sprinkler cap (Viking Part Number 10364).

Sprinklers with Protective Shields or Caps:

- DO NOT remove shields or caps until after sprinkler installation and there no longer is potential for mechanical damage to the sprinkler operating elements.
- **Sprinkler shields or caps MUST be removed BEFORE placing the system in service!**
- Remove the sprinkler shield by carefully pulling it apart where it is snapped together.
- Remove the cap by turning it slightly and pulling it off the sprinkler.

Sprinkler Installation:

- DO NOT use the sprinkler deflector or operating element to start or thread the sprinkler into a fitting.
- **Use only the designated sprinkler head wrench!** Refer to the current sprinkler technical data page to determine the correct wrench for the model of sprinkler used.
- DO NOT install sprinklers onto piping at the floor level.
- Install sprinklers after the piping is in place to prevent mechanical damage.
- DO NOT allow impacts such as hammer blows directly to sprinklers or to fittings, pipe, or couplings in close proximity to sprinklers. Sprinklers can be damaged from direct or indirect impacts.
- DO NOT attempt to remove drywall, paint, etc., from sprinklers.
- **Take care not to over-tighten the sprinkler and/or damage its operating parts!**

Maximum Torque:

1/2" NPT: 14 ft-lbs. (19.0 N-m)

3/4" NPT: 20 ft-lbs. (27.1 N-m)

1" NPT: 30 ft-lbs. (40.7 N-m)



CORRECT
(Original container used)

INCORRECT
(Placed loose in box)

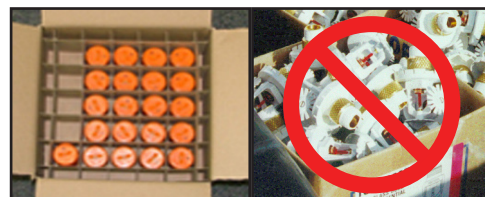

CORRECT
(Protected with caps)

INCORRECT
(Protective caps not used)



CORRECT
(Piping is in place at the ceiling)

INCORRECT
(Sprinkler at floor level)



CORRECT
(Special installation wrenches)

INCORRECT
(Designated wrench not used)



WARNING: Cancer and Reproductive Harm-
www.P65Warnings.ca.gov

! WARNING

Any sprinkler with a loss of liquid from the glass bulb or damage to the fusible element should be destroyed. Never install sprinklers that have been dropped, damaged, or exposed to temperatures exceeding the maximum ambient temperature allowed. Sprinklers that have been painted in the field must be replaced per NFPA 13. Protect sprinklers from paint and paint overspray in accordance with the installation standards. Do not clean sprinklers with soap and water, ammonia, or any other cleaning fluid. Do not use adhesives or solvents on sprinklers or their operating elements.

Refer to the appropriate technical data page and NFPA standards for complete care, handling, installation, and maintenance instructions. For additional product and system information Viking data pages and installation instructions are available on the Viking Web site at www.vikinggroupinc.com.



BULLETIN

CARE AND HANDLING
OF SPRINKLERS

The Viking Corporation, 210 N Industrial Park Drive, Hastings MI 49058
 Telephone: 269-945-9501 Technical Services: 877-384-5464 Fax: 269-818-1680 Email: techsvcs@vikingcorp.com

PROTECTIVE SPRINKLER SHIELDS AND CAPS

General Handling and Storage:

Many Viking sprinklers are available with a plastic protective cap or shield temporarily covering the operating elements. The snap-on shields and caps are factory installed and are intended to help protect the operating elements from mechanical damage during shipping, storage, and installation. NOTE: It is still necessary to follow the care and handling instructions on the appropriate sprinkler technical data sheets* when installing sprinklers with bulb shields or caps.

WHEN TO REMOVE THE SHIELDS AND CAPS:

NOTE: SHIELDS AND CAPS MUST BE REMOVED FROM SPRINKLERS BEFORE PLACING THE SYSTEM IN SERVICE!

Remove the shield or cap from the sprinkler only after checking all of the following:

- The sprinkler has been installed*.
- The wall or ceiling finish work is completed where the sprinkler is installed and there no longer is a potential for mechanical damage to the sprinkler operating elements.

SHIELDS AND CAPS MUST BE REMOVED FROM SPRINKLERS BEFORE PLACING THE SYSTEM IN SERVICE!

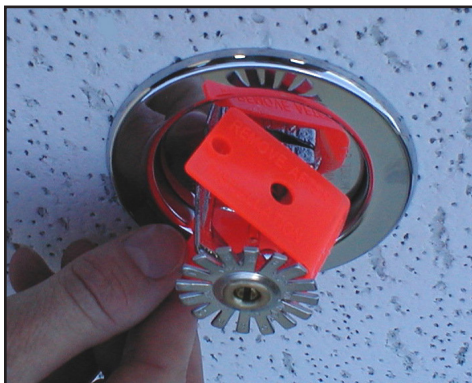

Figure 1: Sprinkler shield being removed from a pendent sprinkler.



Figure 2: Sprinkler cap being removed from a pendent sprinkler.



Figure 3: Sprinkler cap being removed from an upright sprinkler.

HOW TO REMOVE SHIELDS AND CAPS:

No tools are necessary to remove the shields or caps from sprinklers. DO NOT use any sharp objects to remove them! **Take care not to cause mechanical damage to sprinklers when removing the shields or caps.** When removing caps from fusible element sprinklers, use care to prevent dislodging ejector springs or damaging fusible elements. NOTE: Squeezing the sprinkler cap excessively could damage sprinkler fusible elements.

- To remove the shield, simply pull the ends of the shield apart where it is snapped together. Refer to Figure 1.
- To remove the cap, turn it slightly and pull it off the sprinkler. Refer to Figures 2 and 3.

NOTICE

Refer to the current sprinkler technical data page to determine the correct sprinkler wrench for the model of sprinkler used.

WARNING

Never install sprinklers that have been dropped, damaged, or exposed to temperatures in excess of the maximum ambient temperature allowed.

* Refer to the appropriate current technical data pages for complete care, handling, and installation instructions. Data pages are included with each shipment from Viking or Viking distributors. They can also be found on the Web site at www.vikinggroupinc.com.



BULLETIN

CARE AND HANDLING
OF SPRINKLERS

The Viking Corporation, 210 N Industrial Park Drive, Hastings MI 49058
 Telephone: 269-945-9501 Technical Services: 877-384-5464 Fax: 269-818-1680 Email: techsvcs@vikingcorp.com



CONCEALED COVER ASSEMBLIES ARE FRAGILE!
TO ASSURE SATISFACTORY PERFORMANCE OF THE PRODUCT, HANDLE WITH CARE.

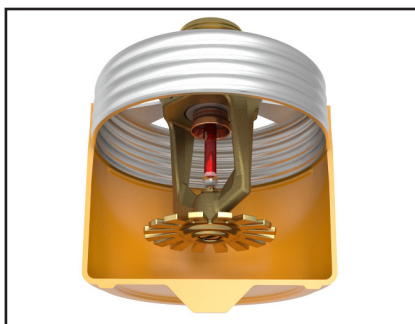

Concealed Sprinkler and Adapter
 Assembly with Protective Cap

Concealed Sprinkler and Adapter
 Assembly (Protective Cap Removed)



Cover Plate Assembly
 (Pendent Cover 12381 shown)



GENERAL HANDLING AND STORAGE INSTRUCTIONS:

- Do not store in temperatures exceeding 100 °F (38 °C). Avoid direct sunlight and confined areas subject to heat.
- Protect sprinklers and cover assemblies during storage, transport, handling, and after installation.
 - Use original shipping containers.
 - Do not place sprinklers or cover assemblies loose in boxes, bins, or buckets.
- Keep the sprinkler bodies covered with the protective sprinkler cap any time the sprinklers are shipped or handled, during testing of the system, and while ceiling finish work is being completed.
- Use only the designated Viking recessed sprinkler wrench (refer to the appropriate sprinkler data page) to install these sprinklers. **NOTE:** The protective cap is temporarily removed during installation and then placed back on the sprinkler for protection until finish work is completed.
- Do not over-tighten the sprinklers into fittings during installation.
- Do not use the sprinkler deflector to start or thread the sprinklers into fittings during installation.
- Do not attempt to remove drywall, paint, etc., from the sprinklers.
- Remove the plastic protective cap from the sprinkler before attaching the cover plate assembly. **PROTECTIVE CAPS MUST BE REMOVED FROM SPRINKLERS BEFORE PLACING THE SYSTEM IN SERVICE!**

Refer to the appropriate current technical data pages for complete care, handling, and installation instructions. Data pages are included with each shipment from Viking or Viking distributors. They can also be found on the Web site at www.vikinggroupinc.com.



BULLETIN

CARE AND HANDLING
OF SPRINKLERS

The Viking Corporation, 210 N Industrial Park Drive, Hastings MI 49058

Telephone: 269-945-9501 Technical Services: 877-384-5464 Fax: 269-818-1680 Email: techsvcs@vikingcorp.com

USE THE FOLLOWING PRECAUTIONS WHEN HANDLING WAX-COATED SPRINKLERS

Many of Viking's sprinklers are available with factory-applied wax coating for corrosion resistance. These sprinklers MUST receive appropriate care and handling to avoid damaging the wax coating and to assure satisfactory performance of the product.

General Handling and Storage of Wax-Coated Sprinklers:

- Store the sprinklers in a cool, dry place (in temperatures below the maximum ambient temperature allowed for the sprinkler temperature rating. Refer to Table 1 below.)
- Store containers of wax-coated sprinklers separate from other sprinklers.
- Protect the sprinklers during storage, transport, handling, and after installation.
- Use original shipping containers.
- Do not place sprinklers in loose boxes, bins, or buckets.

Installation of Wax-Coated Sprinklers:

Use only the special sprinkler head wrench designed for installing wax-coated Viking sprinklers (any other wrench may damage the unit).

- Take care not to crack the wax coating on the units.
- For touching up the wax coating after installation, wax is available from Viking in bar form. Refer to Table 1 below. The coating MUST be repaired after sprinkler installation to protect the corrosion-resistant properties of the sprinkler.
- Use care when locating sprinklers near fixtures that can generate heat. Do not install sprinklers where they would be exposed to temperatures exceeding the maximum recommended ambient temperature for the temperature rating used.
- Inspect the coated sprinklers frequently soon after installation to verify the integrity of the corrosion resistant coating. Thereafter, inspect representative samples of the coated sprinklers in accordance with NFPA 25. Close up visual inspections are necessary to determine whether the sprinklers are being affected by corrosive conditions.

TABLE 1

Sprinkler Temperature Rating (Fusing Point)	Wax Part Number	Wax Melting Point	Maximum Ambient Ceiling Temperature ¹	Wax Color
155 °F (68 °C) / 165 °F (74 °C)	02568A	148 °F (64 °C)	100 °F (38 °C)	Light Brown
175 °F (79 °C)	04146A	161 °F (71 °C)	150 °F (65 °C)	Brown
200 °F (93 °C)	04146A	161 °F (71 °C)	150 °F (65 °C)	Brown
220 °F (104 °C)	02569A	170 °F (76 °C)	150 °F (65 °C)	Dark Brown
286 °F (141 °C)	02569A	170 °F (76 °C)	150 °F (65 °C)	Dark Brown

¹ Based on NFPA-13. Other limits may apply, depending on fire loading, sprinkler location, and other requirements of the Authority Having Jurisdiction. Refer to specific installation standards.



Never install sprinklers that have been dropped, damaged, or exposed to temperatures in excess of the maximum ambient temperature allowed.

Refer to the appropriate current technical data pages for complete care, handling, and installation instructions. Data pages are included with each shipment from Viking or Viking distributors. They can also be found on the Web site at www.vikinggroupinc.com.

**BULLETIN****REGULATORY AND HEALTH
WARNINGS**

The Viking Corporation, 210 N Industrial Park Drive, Hastings MI 49058

Telephone: 269-945-9501 Technical Services: 877-384-5464 Fax: 269-818-1680 Email: techsvcs@vikingcorp.com

Visit the Viking website for the latest edition of this technical data page www.vikinggroupinc.com

1. DESCRIPTION

Regulatory and Health Warnings applying to materials used in the manufacture and construction of fire protection products are provided herein as they relate to legally mandated jurisdictional regions.

⚠ WARNING**STATE OF CALIFORNIA, USA**

Installing or servicing fire protection products such as sprinklers, valves, piping etc. can expose you to chemicals including, but not limited to, lead, nickel, butadiene, titanium dioxide, chromium, carbon black, and acrylonitrile which are known to the State of California to cause cancer or birth defects or other reproductive harm.

For more information, go to www.P65Warnings.ca.gov

2. WARRANTY TERMS AND CONDITIONS

For details of warranty, refer to Viking's current list price schedule at www.vikinggroupinc.com or contact Viking directly.