



**TECHNICAL DATA**

**MODEL EG-100  
ESFR SPRINKLER GUARD**

The Viking Corporation, 210 N Industrial Park Drive, Hastings MI 49058  
 Telephone: 269-945-9501 Technical Services: 877-384-5464 Fax: 269-818-1680 Email: techsvcs@vikingcorp.com  
 Visit the Viking website for the latest edition of this technical data page www.vikinggroupinc.com

**1. DESCRIPTION**

Viking ESFR Sprinkler Guards are used in conjunction with ESFR style sprinklers where allowed by the approvals. (Refer to the Approval Charts) The guards are hard-wire cages designed to surround the sprinklers and protect them from mechanical damage. They are recommended for areas where sprinklers are installed at a low elevation and/or near a high degree of human or mechanical activity.



**2. LISTINGS AND APPROVALS**



**FM Approved: Class 2091**

The Model EG-100 Sprinkler Guard is ONLY Approved for use with the following sprinklers: VK506, VK510, and VK514  
 Also FM approved for intermediate-level use, such as in-rack, under conveyors, mezzanines, or other similar obstructions. Refer to the Approval Chart.

**3. TECHNICAL DATA**

**Material Standards:**

**Guard (flat steel):** Carbon Steel

**Guard (wire):** Cold Drawn Steel Wire

**Screw:** 6-32 x 3/8 (R.H. Phillips-Slotted Combination Drive): Steel

**Screw Finish:** Zinc Plate

**Rivet:** Carbon Steel

**Pins:** Carbon Steel

**Ordering Information:**

**TABLE 1: ORDERING INFORMATION AND DIMENSIONS**

Part Number	Description	Size
		NPT
24988F	Guard, ESFR, Chrome	1"
24988M/R	Guard, ESFR, Painted (red)	1"

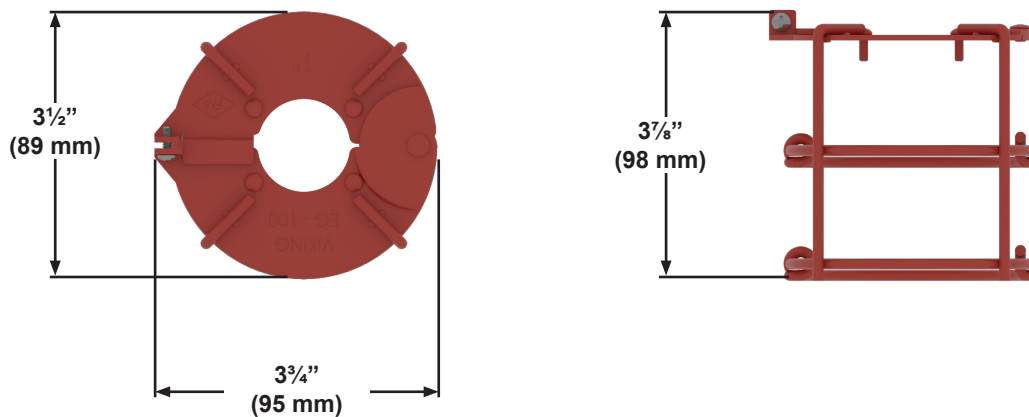
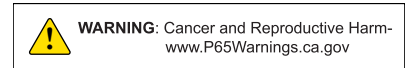

**Figure 1: Dimensions**  
 All dimensions are approximate.



## TECHNICAL DATA

## MODEL EG-100 ESFR SPRINKLER GUARD

The Viking Corporation, 210 N Industrial Park Drive, Hastings MI 49058  
 Telephone: 269-945-9501 Technical Services: 877-384-5464 Fax: 269-818-1680 Email: techsvcs@vikingcorp.com  
 Visit the Viking website for the latest edition of this technical data page [www.vikinggroupinc.com](http://www.vikinggroupinc.com)

### 4. INSTALLATION

#### NOTICE

Improper installation can impede the sprinkler operation.  
 ► Follow the procedures in this document to properly install the sprinkler guard.

#### Installing the ESFR Sprinkler Guard on the Sprinkler

Tool needed:

#2 R.H. Phillips or Flat Head screwdriver (not available from Viking.)

Procedure:

1. Loosen the screw and open the guard.
2. Place the guard around the sprinkler as shown. Be sure the pins line up with the sprinkler frame as shown.

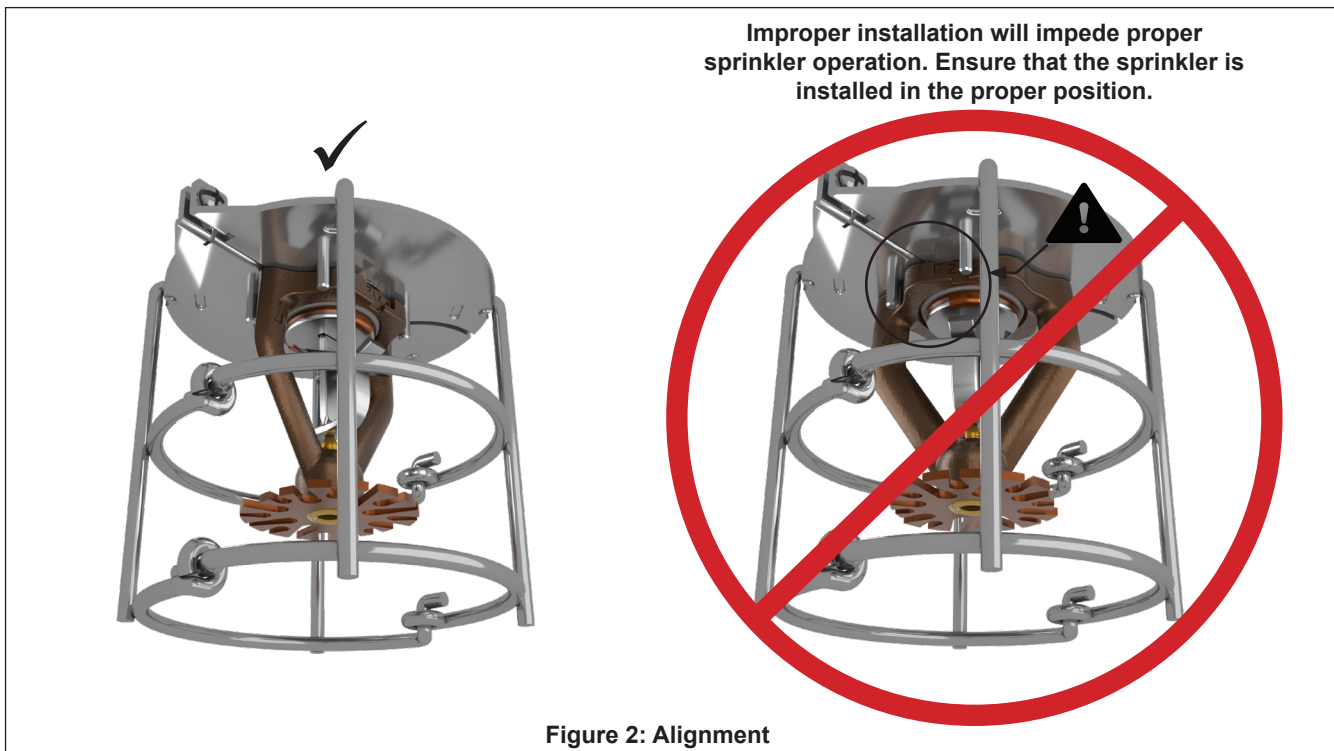

	<b>TECHNICAL DATA</b>	<b>MODEL EG-100 ESFR SPRINKLER GUARD</b>
---	-----------------------	--

The Viking Corporation, 210 N Industrial Park Drive, Hastings MI 49058  
 Telephone: 269-945-9501 Technical Services: 877-384-5464 Fax: 269-818-1680 Email: techsvcs@vikingcorp.com  
 Visit the Viking website for the latest edition of this technical data page [www.vikinggroupinc.com](http://www.vikinggroupinc.com)

3. Close the guard and tighten the screw.

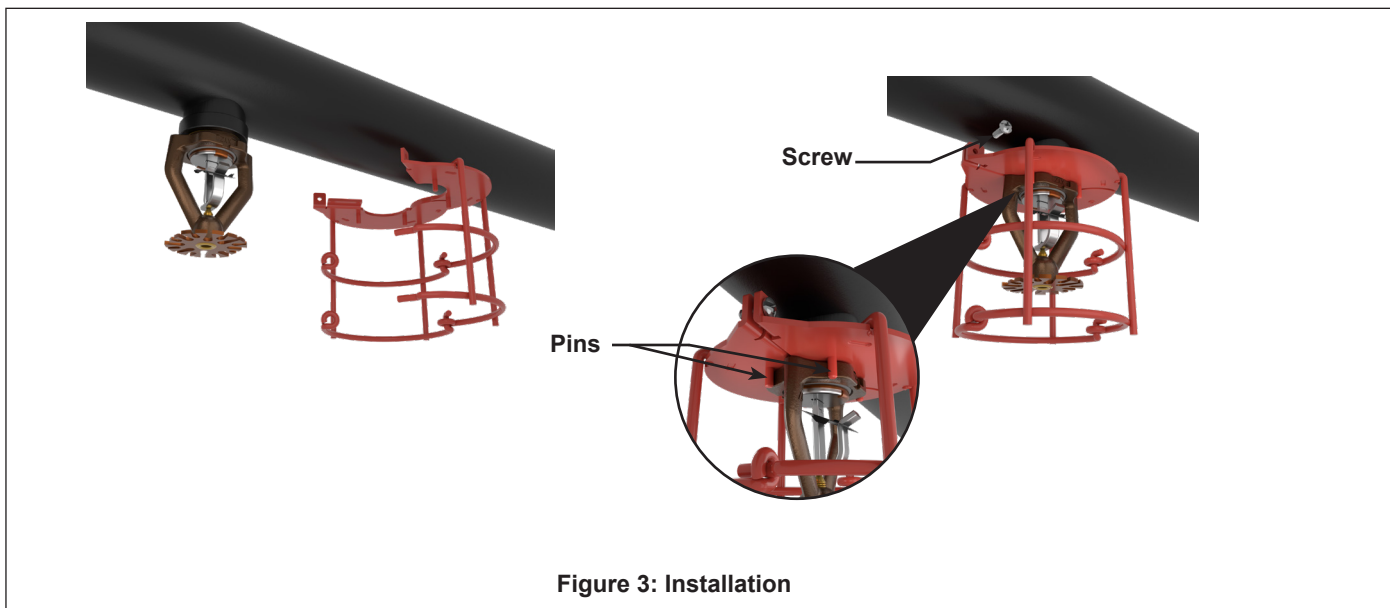

**5. OPERATION**

Refer to the sprinkler technical data page for the sprinkler model used. The ESFR Sprinkler Guard is a hard-wire cage designed to surround the sprinkler and protect it from mechanical damage.

**6. INSPECTIONS, TESTS, AND MAINTENANCE**

Refer to NFPA 25 for Inspection, Testing and Maintenance requirements.

**7. AVAILABILITY**

Viking ESFR Sprinkler Guards are available through a network of domestic and international distributors. See the Viking website for the closest distributor or contact Viking.

**8. GUARANTEE**

For details of warranty, refer to the current list price schedule or contact us directly.

Approval Chart						
Model EG-100 Sprinkler Guard with VK506, VK510, and VK514						
SIN	Type	Available Thread Sizes		Nominal K-Factor		Approvals
		NPT	BSPT	U.S.	metric	FM <sup>1</sup>
VK506	ESFR Pendent	1"	25mm	22.4	320	✓
VK510	ESFR Pendent	1"	25mm	25.2	363	✓
VK514	ESFR Pendent	1"	25mm	28.0	404	✓

1. FM approved for intermediate-level use, such as in-rack, under conveyors, mezzanines, or other similar obstructions.