



Viking Residential Sprinkler Installation Guide

October 25, 2018



WARNING: Cancer and Reproductive Harm-
www.P65Warnings.ca.gov

Trusted Above All™

www.vikinggroupinc.com



TECHNICAL DATA

FREEDOM® RESIDENTIAL SPRINKLER INSTALLATION GUIDE

The Viking Corporation, 210 N Industrial Park Drive, Hastings MI 49058

Telephone: 269-945-9501 Technical Services: 877-384-5464 Fax: 269-818-1680 Email: techsvcs@vikingcorp.com

1. DESCRIPTION

Viking residential automatic sprinklers are equipped with a “fast response” heat-sensitive operating element designed to respond individually and quickly to a specific high temperature. Viking residential sprinklers are designed to combine speed of operation with water distribution characteristics to help in the control of residential fires and to improve life safety by prolonging the time available for occupants to escape or be evacuated.

2. LISTINGS AND APPROVALS

Refer to the Approval Charts on the appropriate sprinkler technical data page(s) and/or approval agency listings.

- A. Viking residential sprinklers are intended for use in the following occupancies: one- and two-family dwellings and mobile homes with the fire protection sprinkler system installed in accordance with NFPA 13D; residential occupancies up to four stories in height with the fire protection system installed in accordance with NFPA 13R; or residential portions of any occupancy with the fire protection system installed in accordance with NFPA 13. Information contained in this guide is based on NFPA 13, “Standard for the Installation of Sprinkler Systems”.
- B. The design criteria for residential sprinklers contained in the NFPA installation standards must be followed except as modified by the individual UL 1626 listing information provided in the technical data pages and this Residential Sprinkler Installation Guide. For listed areas of coverage, technical data, and specific design and installation instructions, refer to the appropriate Viking technical data page for the sprinkler model used.
- C. Viking residential sprinklers listed by Underwriters Laboratories, Inc. (UL) have passed fire tests designed to represent fire conditions for the sprinkler’s listed area of coverage. The standards for residential sprinkler performance and spray patterns are printed in Underwriters Laboratories Publication UL 1626, “Standard for Residential Sprinklers for Fire Protection Service”. All listed Viking residential sprinklers meet or exceed UL 1626 performance requirements and spray pattern criteria for their listed areas of coverage.
- D. NFPA standards allow use of residential sprinklers with rates, design areas, areas of coverage, and minimum design pressures other than those specified in the standards when they have been listed for such specific residential installation conditions.

3. TECHNICAL DATA

Specifications:

Refer to the appropriate sprinkler technical data sheet.

Material Standards:

Refer to the appropriate sprinkler technical data sheet.

Viking Technical Data may be found on
The Viking Corporation’s Web site at
<http://www.vikinggroupinc.com>.
The Web site may include a more recent
edition of this Technical Data Page.

4. INSTALLATION

NOTE: Take care not to over-tighten the sprinkler and/or damage its operating parts!

Maximum Torque: 1/2” NPT: 14 ft-lbs. (19.0 N-m) 3/4” NPT: 20 ft-lbs. (27.1 N-m)

A. Care and Handling (also refer to Bulletin - Care and Handling of Sprinklers, Form No. F_091699.)

Sprinklers must be handled with care and protected from mechanical damage during storage, transport, handling, and after installation.

Store sprinklers in a cool, dry place in their original container.

Use care when locating sprinklers near fixtures that can generate heat.

Never install sprinklers that have been dropped, damaged in any way, or exposed to temperatures exceeding the maximum ambient temperature allowed (refer to Table 1.)

Never install any glass-bulb sprinkler if the bulb is cracked or if there is a loss of liquid from the bulb. A small air bubble should be present in the glass bulb. Any sprinkler with a loss of liquid from the glass bulb or damage to the fusible element should be destroyed immediately. (Note: Installing glass bulb sprinklers in direct sunlight (ultraviolet light) may affect the color of the dye used to color code the bulb. This color change does not affect the integrity of the bulb.)

Viking residential sprinklers are intended for use on wet pipe residential systems only. Adequate heat must be provided for wet-pipe systems. DO NOT use Viking residential sprinklers on dry systems unless specifically allowed by recognized installation standards or the Authority Having Jurisdiction.

Residential concealed sprinklers must be installed in neutral or negative pressure plenums only!

Corrosion-resistant sprinklers must be installed when subject to corrosive atmospheres. **NOTE:** Viking residential sprinklers are not intended for use in corrosive environments.

Replaces pages 1-17, dated December 1, 2016.

(Added P65 Warning.)



TECHNICAL DATA

FREEDOM® RESIDENTIAL SPRINKLER INSTALLATION GUIDE

The Viking Corporation, 210 N Industrial Park Drive, Hastings MI 49058
 Telephone: 269-945-9501 Technical Services: 877-384-5464 Fax: 269-818-1680 Email: techsvcs@vikingcorp.com

TABLE 1: RESIDENTIAL SPRINKLER TEMPERATURE RATINGS

Sprinkler Temperature Classification	Sprinkler Nominal Temperature Rating ¹	Maximum Ambient Ceiling Temperature ³	Bulb Color
Residential Glass Bulb Style Sprinklers			
Ordinary	155 °F (68 °C)	100 °F (38 °C)	Red
Intermediate	175 °F (79 °C)	150 °F (65 °C)	Yellow
Sprinkler Temperature Classification	Sprinkler Nominal Temperature Rating (Fusing Point) ¹	Maximum Ambient Ceiling Temperature ³	
Residential Fusible Element Style Sprinklers			
Ordinary	165 °F (74 °C)	100 °F (38 °C)	
Sprinkler Temperature Classification	Sprinkler Nominal Temperature Rating (Fusing Point)	Maximum Ambient Ceiling Temperature ³	Temperature Identification Stamp
Residential Flush Style Sprinklers			
Ordinary	165 °F (74 °C)	100 °F (38 °C)	On Cover or Sprinkler Inlet (VK476)
Intermediate	220 °F (104 °C)	150 °F (65 °C)	On Cover
Sprinkler Temperature Classification	Sprinkler Nominal Temperature Rating (Fusing Point)	Maximum Ambient Ceiling Temperature ³	Cover Plate Temperature Rating
Residential Concealed Style Sprinklers			
Ordinary	135 °F (57 °C) ¹ , 140 °F (60 °C) ² , 155 °F (68 °C) ¹ , or 165 °F (74 °C) ¹	100 °F (38 °C)	135 °F (57 °C)

Footnotes

¹ The sprinkler temperature rating is stamped on the deflector or flow shaper.

² The temperature rating is stamped on the sprinkler.

³ Based on NFPA-13. Other limits may apply, depending on fire loading, sprinkler location, and other requirements of the Authority Having Jurisdiction. Refer to specific installation standards.

B. Installation Instructions

Viking sprinklers are manufactured and tested to meet the rigid requirements of approving agencies. They are designed to be installed in accordance with recognized installation standards NFPA 13, NFPA 13R, and NFPA 13D, and any associated TIAs.

Deviation from the standards or any alteration to the sprinklers or cover plate assemblies after they leave the factory including, but not limited to: painting, plating, coating, or modification, may render the sprinklers inoperative and will automatically nullify the approval and any guarantee made by Viking.

The use of residential sprinklers may be limited due to occupancy and hazard. Residential fire protection systems must be designed and installed only by those who are completely familiar with the appropriate standards and codes, and thoroughly experienced in fire protection design, hydraulic calculations, and sprinkler system installation.

Before installation, be sure to have the appropriate sprinkler model and style, with the correct K-Factor, temperature rating, and response characteristics. Viking residential sprinklers must be installed after the piping is in place to prevent mechanical damage. Keep sprinklers with protective caps or bulb shields contained within the caps or shields during installation and testing, and any time the sprinkler is shipped or handled.

1a. For frame-style sprinklers, install escutcheon (if used), which is designed to thread onto the external threads of the sprinkler*.

*Refer to the appropriate sprinkler technical data page to determine approved escutcheons for use with specific sprinkler models.

1b. For flush and concealed style sprinklers: Cut the sprinkler nipple so that the ½" or ¾" (15 mm or 20 mm) NPT** outlet of the reducing coupling is at the desired location and centered in the opening** in the ceiling or wall.

**Size depends on the sprinkler model used. Refer to appropriate sprinkler data page.



TECHNICAL DATA

FREEDOM® RESIDENTIAL SPRINKLER INSTALLATION GUIDE

The Viking Corporation, 210 N Industrial Park Drive, Hastings MI 49058

Telephone: 269-945-9501 Technical Services: 877-384-5464 Fax: 269-818-1680 Email: techsvcs@vikingcorp.com

DESIGN CRITERIA

For Systems Designed to NFPA 13D or NFPA 13R: Apply the listed areas of coverage and minimum water supply requirements shown in the approval charts on the residential sprinkler data pages. The sprinkler flow rate is the minimum required discharge from each of the total number of design sprinklers as specified in NFPA 13D or NFPA 13R.

For Systems Designed to the latest edition of NFPA 13: The number of design sprinklers is to be the four most hydraulically demanding sprinklers. The minimum required discharge from each of the four sprinklers is to be the greater of the following:

- The flow rates given in the approval charts on the data pages for NFPA 13D and NFPA13R for each area of coverage listed, or
- Calculated based on a minimum discharge of 0.1 gpm/sq. ft. over the “design area” in accordance with sections 8.5.2.1 or 8.6.2.1.2 of NFPA 13. The greatest dimension of the coverage area cannot be any greater than the maximum areas of coverage shown on the data pages.

Flow Rates

All residential sprinklers manufactured on or after July 12, 2002 are listed with a single minimum flow rate. Where rooms have more than one sprinkler, multiple-sprinkler calculations are still required, but the first sprinkler and any additional sprinkler or sprinklers must be calculated flowing at identical minimum flow rates, based on the area of sprinkler coverage, using the minimum flow and pressure listed for the sprinkler model used.

Consult the appropriate standards and the Authorities Having Jurisdiction to determine the number of sprinklers to hydraulically calculate to verify adequate water supply for multiple-sprinkler operation.

Operating Pressure: The minimum operating pressure of any sprinkler shall be the minimum operating pressure specified by the listing, or 7 psi (0.5 bar), whichever is greater. The maximum allowable operating pressure is 175 psi (12 bar).

Areas of Coverage

If the actual area of coverage is less than the listed area of coverage, use the minimum water supply for the next larger area of coverage listed. DO NOT interpolate. Residential sprinkler systems must be hydraulically calculated according to NFPA standards to verify that the water supply is adequate for proper operation of the sprinklers. Hydraulic calculations are required to verify adequate water supply at the hydraulically most remote single sprinkler when it is operating at the minimum gpm and psi listed for single-sprinkler operation for the sprinkler model used.

Viking residential sprinklers may be listed for more than one area of coverage. Suggested practice in selecting area of coverage is to select the one that can be adequately supplied by the available water supply and still allow for the installation of as few sprinklers in a compartment as possible while observing all guidelines pertaining to obstructions and spacing. This maximizes the use of the available water supply, which is often limited on residential fire protection systems. After selecting an appropriate area of coverage, sprinklers must be spaced according to guidelines set forth in the installation standards.

Definition of “COMPARTMENT”: A space completely enclosed by walls and a ceiling. Openings to an adjoining space are allowed, provided the openings have a minimum lintel depth of 8 in. (203.2 mm) from the ceiling.

Spacing Guidelines

For guidelines concerning spacing of Viking residential sprinklers near beams, obstructions, heat sources, and sloped ceilings [slopes more than a 2/12 (9.5°) pitch], refer to the Viking residential sprinkler data pages and installation guide, the appropriate NFPA standard, and the Authority Having Jurisdiction. NOTE: Sloped, beamed, and pitched ceilings could require special design features such as larger flow, or a design for more sprinklers to operate in the compartment, or both.

Distance from Walls: Install not more than one-half the listed sprinkler spacing nor less than 4” (102 mm) from walls, partitions, or obstructions as defined in the standards.

Minimum Sprinkler Spacing: The minimum distance between residential sprinklers to prevent cold soldering (i.e., the spray from one operating sprinkler onto an adjacent sprinkler that could prevent its proper activation) is 8 ft. (2.4 m).

Maximum Sprinkler Spacing: Locate adjacent sprinklers no farther apart than the listed spacing.

Deflector Position: Install frame style residential *pendent* sprinklers with the deflector between 1” and 4” (25.4 mm to 102 mm) below smooth ceilings, unless the sprinkler data page indicates otherwise. Install pendent sprinklers in the pendent position only, with the deflector oriented parallel with the ceiling or roof.

Refer to the individual listings in the residential sprinkler data pages for horizontal sidewall sprinkler deflector or sprinkler centerline distance below the ceiling. Install horizontal sidewall sprinklers in the horizontal position only below smooth ceilings, with the leading edge of the deflector or element assembly oriented parallel with the ceiling.

IMPORTANT: Always refer to Bulletin Form No. F_091699 - Care and Handling of Sprinklers. Also refer to the appropriate sprinkler data page. Viking sprinklers are to be installed in accordance with the latest edition of Viking technical data, the appropriate standards of NFPA and any other similar Authorities Having Jurisdiction, and also with the provisions of governmental codes, ordinances, and standards, whenever applicable. Final approval and acceptance of all residential sprinkler installations must be obtained from the Authorities Having Jurisdiction.



TECHNICAL DATA

FREEDOM® RESIDENTIAL SPRINKLER INSTALLATION GUIDE

The Viking Corporation, 210 N Industrial Park Drive, Hastings MI 49058

Telephone: 269-945-9501 Technical Services: 877-384-5464 Fax: 269-818-1680 Email: techsvcs@vikingcorp.com

2. Apply a small amount of pipe-joint compound or tape to the external threads of the sprinkler only, taking care not to allow a build-up of compound in the sprinkler inlet. **NOTE:** Sprinklers with protective caps or bulb shields must be contained within the caps or shields before applying pipe-joint compound or tape. *Exception: For concealed sprinklers (i.e., VK457, VK458, VK468, VK474, and VK4570) the protective cap is removed for installation.*
3. Care must be taken when installing sprinklers on CPVC and copper piping systems. Never install the sprinkler into the reducing fitting before attaching the reducing fitting to the piping. Sprinklers must be installed on CPVC systems after the reducing fitting has been installed and the primer and/or cement manufacturer's recommended curing time has elapsed. When installing sprinklers on copper piping systems, take care to brush the inside of the sprinkler supply piping and reducing fitting to ensure that no flux accumulates in the sprinkler orifice. Excess flux can cause corrosion and may impair the ability of the sprinkler to operate properly.
4. Refer to the appropriate sprinkler technical data page to determine the correct sprinkler wrench for the model of sprinkler used. DO NOT use the sprinkler deflector or fusible element to start or thread the sprinkler into a fitting.
 - a. Install the sprinkler onto the piping using the special sprinkler wrench only, while taking care not to over-tighten or damage the sprinkler operating parts.
 - b. Thread the flush or concealed sprinkler into the 1/2" or 3/4" (15 mm or 20 mm) NPT** outlet of the coupling by turning it clockwise with the special sprinkler wrench. *NOTE: For flush and concealed sprinklers with protective shells, the internal diameter of the special flush and concealed sprinkler installation wrench is designed for use with the sprinkler contained within the shell. Exception: For concealed sprinklers VK457, VK458, VK468, VK474, and VK4570 the protective cap is removed for installation, and then placed back on the sprinkler temporarily.*
5. After installation, the entire sprinkler system must be tested. The test must be conducted to comply with the installation standards.
 - a. Make sure the sprinkler has been properly tightened. If a thread leak occurs, normally the unit must be removed, new pipe-joint compound or tape applied, and then reinstalled. This is due to the fact that when the joint seal leaks, the sealing compound is washed out of the joint.
 - b. **Remove plastic protective sprinkler caps or bulb shields AFTER the wall or ceiling finish work is completed where the sprinkler is installed and there no longer is a potential for mechanical damage to the sprinkler operating elements.** To remove the bulb shields, simply pull the ends of the shields apart where they are snapped together. To remove caps from frame style sprinklers, turn the caps slightly and pull them off the sprinklers. **SPRINKLER CAPS OR BULB SHIELDS MUST BE REMOVED FROM SPRINKLERS BEFORE PLACING THE SYSTEM IN SERVICE!** Retain a protective cap or shield in the spare sprinkler cabinet.
6. For residential flush sprinklers, the ceiling ring can now be installed onto the sprinkler body. Align the ceiling ring with the sprinkler body and thread on or push it on until the flange touches the ceiling. Note the maximum vertical adjustment is 1/2" (12,7 mm) for sprinkler VK420 and 5/8" for VK476. DO NOT MODIFY THE UNIT. If necessary, re-cut the sprinkler drop nipples as required.
7. For residential concealed sprinklers, the cover plate assembly can now be attached.
 - a. Remove the cover plate assembly from the protective box, taking care not to damage the assembly.
 - b. From below the ceiling, gently place the base of the cover plate assembly over the sprinkler protruding through the opening in the ceiling or wall.
 - c. Carefully push the cover plate assembly onto the sprinkler, using even pressure with the palm of the hand, until the unfinished brass flange of the cover plate base touches the ceiling or wall.
 - d. The maximum adjustment available for residential concealed sprinklers is 1/2" (12.7 mm) [1/4" (6.4 mm) for sprinkler VK480]. DO NOT MODIFY THE UNIT. If necessary, re-cut the sprinkler nipples.

NOTE: If it is necessary to remove the entire sprinkler unit, the system must be taken out of service. See Maintenance instructions below and follow all warnings and instructions.

5. OPERATION

During fire conditions, the operating element fuses or shatters (depending on the type of sprinkler), releasing the pip cap and sealing assembly. Water flowing through the sprinkler orifice strikes the sprinkler deflector or flow shaper, forming a uniform, high-wall wetting spray pattern to extinguish or control the fire.



TECHNICAL DATA

FREEDOM® RESIDENTIAL SPRINKLER INSTALLATION GUIDE

The Viking Corporation, 210 N Industrial Park Drive, Hastings MI 49058

Telephone: 269-945-9501 Technical Services: 877-384-5464 Fax: 269-818-1680 Email: techsvcs@vikingcorp.com

6. INSPECTIONS, TESTS AND MAINTENANCE

Refer to NFPA 25 for Inspection, Testing and Maintenance requirements. **NOTICE:** The owner is responsible for having the fire-protection system and devices inspected, tested, and maintained in proper operating condition in accordance with this guide, and applicable NFPA standards. In addition, the Authority Having Jurisdiction may have additional maintenance, testing, and inspection requirements that must be followed.

- A. Sprinklers must be inspected on a regular basis for signs of corrosion, mechanical damage, obstructions, paint, etc. Frequency of the inspections may vary due to corrosive atmospheres, water supplies, and activity around the device.
- B. Sprinklers or cover plate assemblies that have been field painted, caulked, or mechanically damaged must be replaced immediately. Sprinklers showing signs of corrosion shall be tested and/or replaced immediately as required. Installation standards require sprinklers to be tested and, if necessary, replaced immediately after a specified term of service. Refer to NFPA 25 and the Authorities Having Jurisdiction for the specified period of time after which testing and/or replacement of residential sprinklers is required. Never attempt to repair or reassemble a sprinkler. Sprinklers and cover assemblies that have operated cannot be reassembled or re-used, but must be replaced. When replacement is necessary, use only new sprinklers and cover assemblies with identical performance characteristics.
- C. The sprinkler discharge pattern is critical for proper fire protection. Nothing should be hung from, attached to, or otherwise obstruct the discharge pattern of the sprinkler. All obstructions must be immediately removed or, if necessary, additional sprinklers installed.
- D. When replacing existing sprinklers, the system must be removed from service. Refer to the appropriate system description and/or valve instructions. Prior to removing the system from service, notify all Authorities Having Jurisdiction. Consideration should be given to employment of a fire patrol in the effected area.
 1. Remove the system from service, drain all water, and relieve all pressure on the piping.
 - 2a. For frame-style sprinklers, use the special sprinkler wrench and remove the old sprinkler by turning it counterclockwise to unthread it from the piping.
 - 2b. *For residential flush pendent and concealed style sprinklers: Remove the ceiling ring or cover plate assembly before unthreading the sprinkler body from the piping. To remove a ceiling ring, grasp it from below the ceiling and gently turn it counterclockwise. Cover plates can be removed either by gently unthreading them or pulling them off the sprinkler body (depends on the sprinkler model used). After the ceiling ring or cover plate assembly has been removed from the sprinkler, use the sprinkler wrench to unthread the sprinkler from the piping. NOTE: For flush and concealed sprinklers with protective shells, the internal diameter of the special flush and concealed sprinkler installation wrench is designed for use with the sprinkler contained within the shell. Place a plastic protective shell (from the spare sprinkler cabinet) over the sprinkler to be removed and then fit the sprinkler wrench over the shell. Exception: Concealed sprinklers VK457, VK458, VK468, VK474, and VK4570 are removed without the plastic cap.*
 3. Follow instructions in section 4B. Installation Instructions to install the new unit. Be sure the replacement sprinkler is the correct model and style, with the appropriate K-Factor, temperature rating, and response characteristics. A fully stocked sprinkler cabinet should be provided for this purpose. *(For flush or concealed style sprinklers, stock of spare ceiling rings or cover plates should also be available in the spare sprinkler cabinet.)*
 4. Place the system back in service and secure all valves. Check for and repair all leaks.
- E. Sprinkler systems that have been subjected to a fire must be returned to service as soon as possible. The entire system must be inspected for damage, and repaired or replaced as necessary. Sprinklers that have been exposed to corrosive products of combustion or high ambient temperatures, but have not operated, should be replaced. Refer to the Authority Having Jurisdiction for minimum replacement requirements.

7. AVAILABILITY

Viking Residential Sprinklers are available through a network of domestic and international distributors. See The Viking Corporation web site for the closest distributor or contact The Viking Corporation.

8. GUARANTEE

For details of warranty, refer to Viking's current list price schedule or contact Viking directly.

	TECHNICAL DATA	FREEDOM® RESIDENTIAL SPRINKLER INSTALLATION GUIDE
---	-----------------------	--

The Viking Corporation, 210 N Industrial Park Drive, Hastings MI 49058
 Telephone: 269-945-9501 Technical Services: 877-384-5464 Fax: 269-818-1680 Email: techsvcs@vikingcorp.com

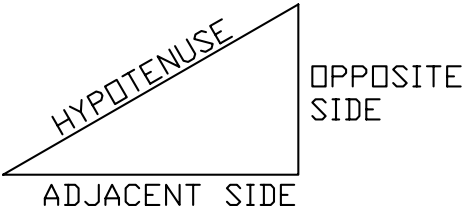

TANGENT =
 OPPOSITE SIDE (RISE)
 ADJACENT SIDE (RUN)

$$\frac{\text{RISE}}{\text{RUN}} = \text{TANGENT}$$

$$\text{ANGLE} = \text{TAN}^{-1} \left(\frac{\text{RISE}}{\text{RUN}} \right)$$

$$\text{SLOPE DISTANCE} = \sqrt{\langle \text{RISE} \rangle^2 + \langle \text{RUN} \rangle^2}$$

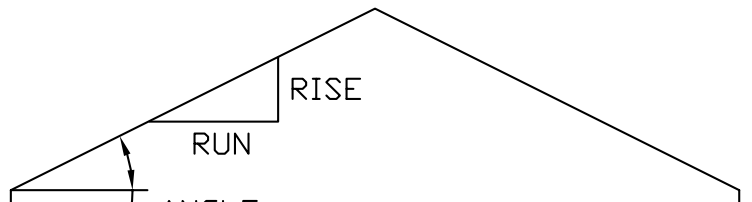

RISE	RUN	TANGENT	ANGLE	SLOPE DISTANCE
2	12	.1666	9.45°	12.1
3	12	.2500	14°	12.3
4	12	.3333	18.4°	12.6
5	12	.4166	22.6°	13
6	12	.5000	26.5°	13.4
7	12	.5833	30.2°	13.8
8	12	.6666	33.6°	14.4
9	12	.7500	36.8°	15
10	12	.8333	39.8°	15.6
11	12	.9166	42.5°	16.2
12	12	1	45°	16.97

Table 2
 Rise Over Run Conversion to Degrees of Slope

	TECHNICAL DATA	FREEDOM® RESIDENTIAL SPRINKLER INSTALLATION GUIDE
---	-----------------------	--

The Viking Corporation, 210 N Industrial Park Drive, Hastings MI 49058
 Telephone: 269-945-9501 Technical Services: 877-384-5464 Fax: 269-818-1680 Email: techsvcs@vikingcorp.com

**SPACING OF RESIDENTIAL SPRINKLERS LISTED FOR USE
BELOW SLOPED CEILINGS UP TO AN 8/12 (33.7°) PITCH**
 (Refer to the appropriate residential sprinkler technical data page for listings.)

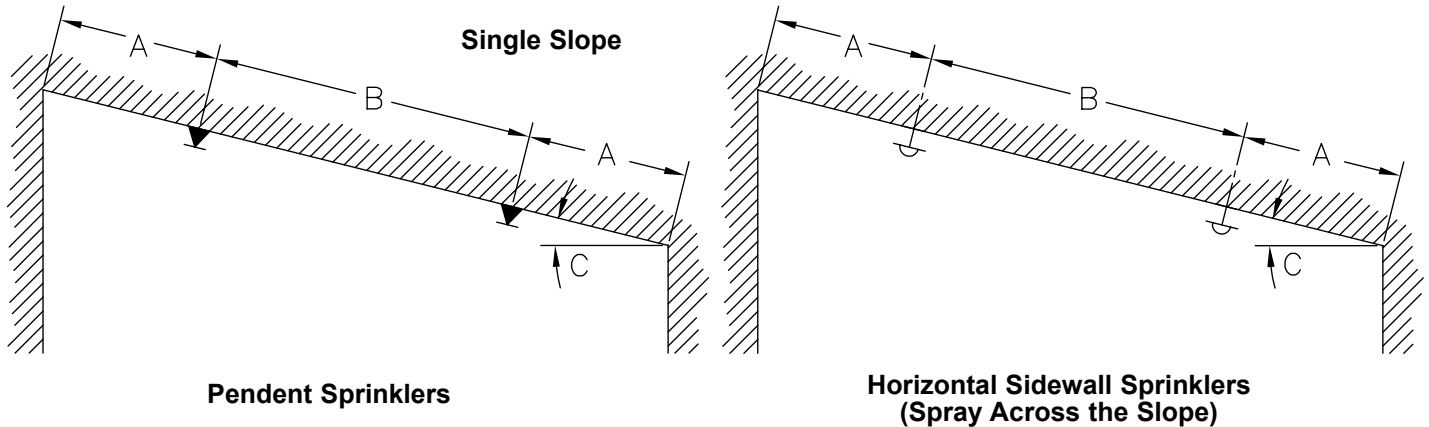

Figure 1

- (A) One-half listed spacing of sprinkler maximum, 0'-4" (0-102 mm) minimum.
- (B) Listed spacing of sprinkler, maximum, 8'-0" (2.4 m) minimum.
- (C) Where angle "C" is greater than an 8/12 (33.7°) pitch, see Figure 2 below.

**SPACING OF RESIDENTIAL SPRINKLERS BELOW SLOPED
CEILINGS WITH GREATER THAN 8/12 (33.7°) PITCH**
 (NOTE: Refer to NFPA 13D or NFPA 13R, and the Authority Having Jurisdiction.)

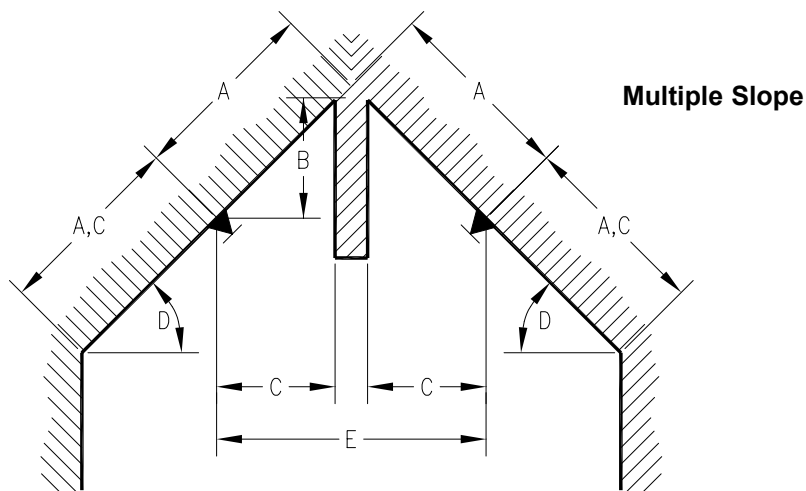

Figure 2

- (A) One-half listed spacing of sprinkler, maximum.
- (B) 3'-0" (.91 m) maximum.
- (C) 0'-4" (0-102 mm) minimum.
- (D) Slopes greater than an 8/12 (33.7°) pitch.
- (E) For distance less than 8'-0" (2.4 m), baffle required.



TECHNICAL DATA

**FREEDOM® RESIDENTIAL
SPRINKLER
INSTALLATION GUIDE**

The Viking Corporation, 210 N Industrial Park Drive, Hastings MI 49058
 Telephone: 269-945-9501 Technical Services: 877-384-5464 Fax: 269-818-1680 Email: techsvcs@vikingcorp.com

**SPACING OF RESIDENTIAL SPRINKLERS LISTED FOR USE
BELOW SLOPED CEILINGS UP TO AN 8/12 (33.7°) PITCH**
 (Refer to the appropriate residential sprinkler technical data page for listings.)

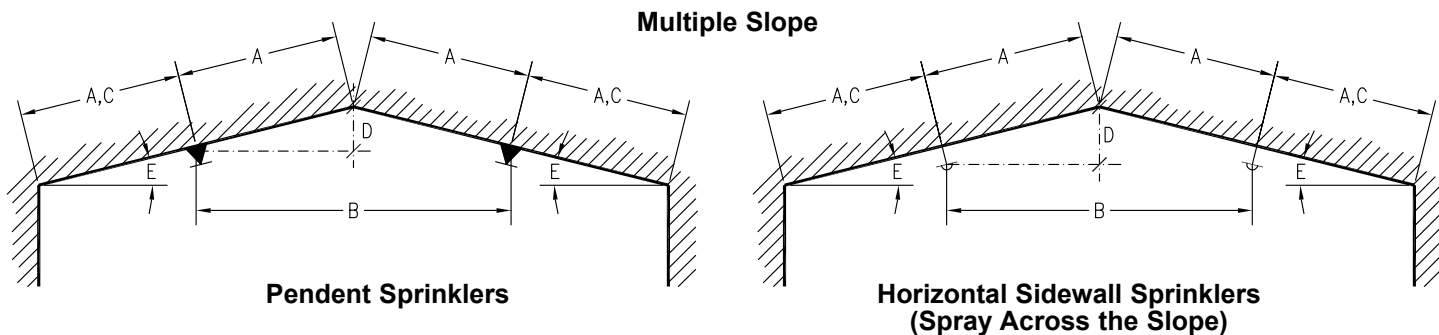

Figure 3

- (A) One-half listed spacing of sprinkler, maximum.
- (B) 8'-0" (2.4 m) minimum.
- (C) 0'-4" (0-102 mm) minimum.
- (D) 3'-0" (.91 m) maximum.
- (E) Acceptable for slopes of 0/12 to 8/12 (0° to 33.7°) pitch.

**SPACING OF RESIDENTIAL PENDENT SPRINKLERS AT PEAK OF SLOPED
CEILINGS WITH PITCH LESS THAN 8/12 (33.7°)**
 (Refer to the appropriate residential sprinkler technical data page for listings.)

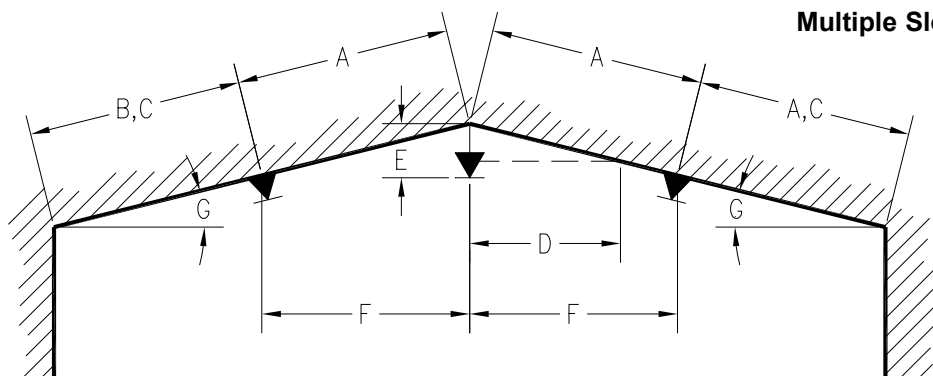

Figure 4

- (A) Listed spacing of sprinkler, maximum.
- (B) One-half listed spacing of sprinkler, maximum.
- (C) 0'-4" minimum.
- (D) Refer to page 10 for minimum distance between sprinkler and intersecting sloped ceiling.
- (E) Refer to the appropriate residential sprinkler technical data page for deflector distance below ceiling.
- (F) 8'-0" minimum.
- (G) Reference: 4/12 (18.0°) pitch maximum for 12' (3.7 m) spacing.
 2.5/12 (12.0°) pitch maximum for 14' (4.3 m) spacing.
 2/12 (10.0°) pitch maximum for 16' (4.9 m) spacing.
 2/12 (10.0°) pitch maximum for 18' (5.5 m) spacing.
 1.9/12 (9.0°) pitch maximum for 20' (6.1 m) spacing.
 Angles based on sprinklers installed 0'-4" (0-102 mm) from peak.

NOTE: Whenever possible, utilize design as shown in Figure 3 above.



TECHNICAL DATA

**FREEDOM® RESIDENTIAL
SPRINKLER
INSTALLATION GUIDE**

The Viking Corporation, 210 N Industrial Park Drive, Hastings MI 49058

Telephone: 269-945-9501 Technical Services: 877-384-5464 Fax: 269-818-1680 Email: techsvcs@vikingcorp.com

SPACING OF RESIDENTIAL SPRINKLERS BELOW SLOPED CEILINGS WITH GREATER THAN 8/12 (33.7°) PITCH WITH NO BAFFLE AND A MAXIMUM OF 2 SPRINKLERS IN THE ROOM
(NOTE: Refer to NFPA 13D or NFPA 13R, and the Authority Having Jurisdiction.)

Multiple Slope

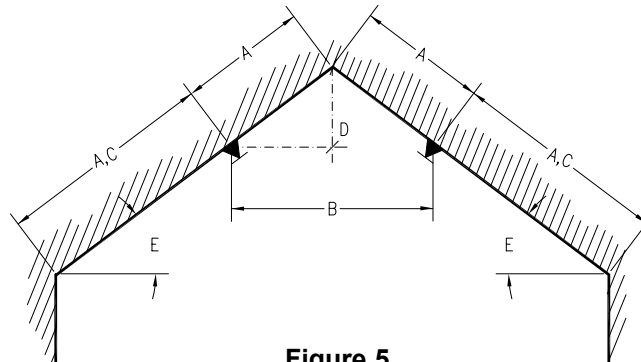

Figure 5

- (A) One-half listed spacing of sprinkler, maximum.
- (B) 8'-0" (2.4 m) minimum.
- (C) 0'-4" (0-102 mm) minimum.
- (D) 3'-0" (.91 m) maximum.
- (E) Acceptable for slopes greater than an 8/12 (33.7°) pitch.
- (F) When this design is used, refer to the appendices of NFPA 13D or NFPA 13R, and the Authority Having Jurisdiction regarding the number of design sprinklers to hydraulically calculate.

SPACING OF RESIDENTIAL SPRINKLERS BELOW CEILINGS WITH SLOPES EXCEEDING 8/12 (33.7°) PITCH WITH NO BAFFLE AND A MAXIMUM OF 3 SPRINKLERS IN THE ROOM
(NOTE: Refer to NFPA 13D or NFPA 13R, and the Authority Having Jurisdiction.)

Multiple Slope

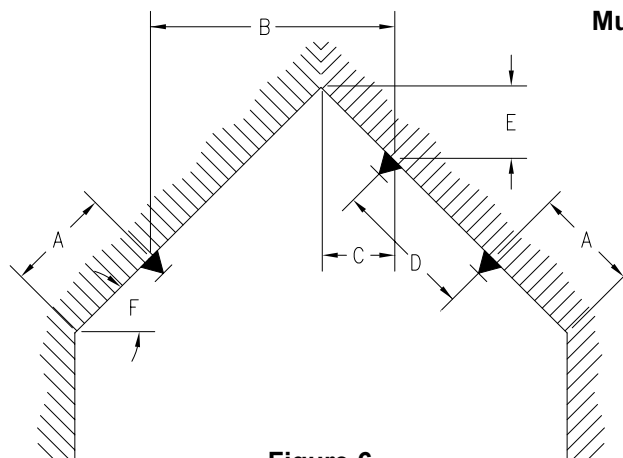

Figure 6

- (A) 0'-4" (0-102 mm) minimum, to one-half listed spacing, maximum.
- (B) One-half listed spacing, maximum, 8'-0" (2.4 m) minimum.
- (C) 0'-4" (0-102 mm) minimum.
- (D) Listed spacing maximum, 8'-0" (2.4 m) minimum.
- (E) 3'-0" (.91 m) maximum.
- (F) Slopes greater than 8/12 up to a 21/12 (33.7° up to 60°) pitch.

NOTES: In addition to the above limits, rooms requiring this type of installation must be hydraulically calculated to supply a minimum of three operating sprinklers. Layout similar for horizontal sidewall sprinklers with throw across slope. Refer to the appropriate residential sprinkler technical data sheets.



TECHNICAL DATA

FREEDOM® RESIDENTIAL
SPRINKLER
INSTALLATION GUIDE

The Viking Corporation, 210 N Industrial Park Drive, Hastings MI 49058
Telephone: 269-945-9501 Technical Services: 877-384-5464 Fax: 269-818-1680 Email: techsvcs@vikingcorp.com

SPACING OF RESIDENTIAL SPRINKLERS BELOW CEILINGS WITH SLOPES EXCEEDING 8/12 (33.7°) PITCH WITH NO BAFFLE AND A MAXIMUM OF 2 SPRINKLERS IN THE ROOM
(NOTE: Refer to NFPA 13D or NFPA 13R, and the Authority Having Jurisdiction.)

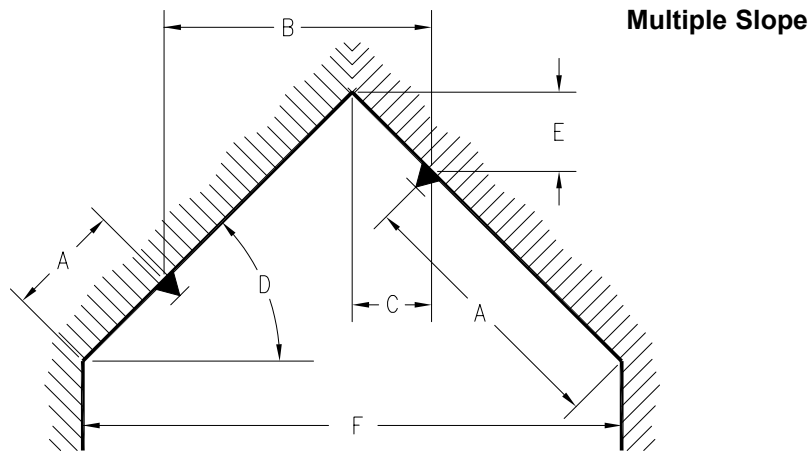

Figure 7

- (A) 0'-4" (0-102 mm) minimum, to one-half listed spacing, maximum.
- (B) One-half listed spacing, maximum, 8'-0" (2.4 m) minimum.
- (C) 0'-4" (0-102 mm) minimum.
- (D) Slopes greater than 8/12 pitch up to a 21/12 (33.7° up to a 60°) pitch.
- (E) 3'-0" (.91 m) maximum.
- (F) When dimension "F" exceeds 16' (4.9 m), utilize design configuration shown in Figure 6.

NOTES: Layout similar for horizontal sidewall sprinklers with throw across slope. Refer to the appropriate residential sprinkler technical data sheets.

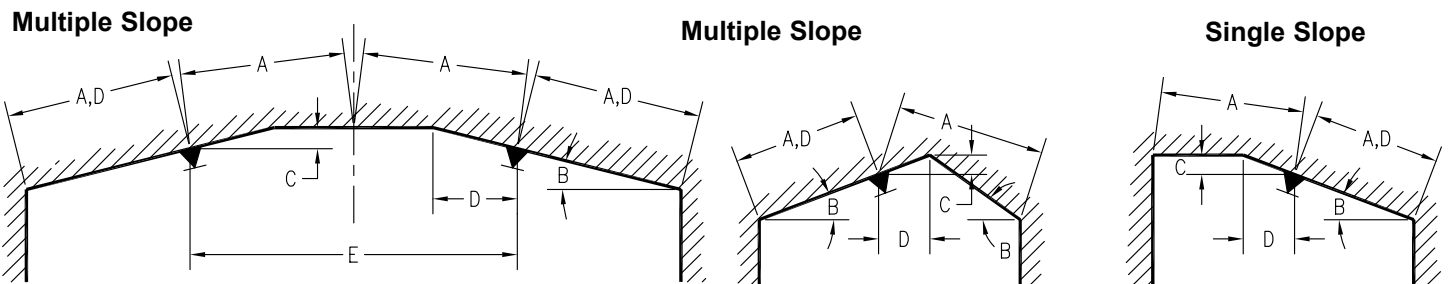

Figure 8

- (A) One-half listed spacing, maximum.
- (B) Refer to the appropriate residential sprinkler technical data pages for listings of sprinklers for use below slopes up to and including a 8/12 (33.7°) pitch.
- (C) 3'-0" (.91 m) maximum.
- (D) 0'-4" (0-102 mm) minimum.
- (E) 8'-0" (2.4 m) minimum without baffle.

NOTES: Layout similar for horizontal sidewall sprinklers with throw across slope. Refer to the appropriate residential sprinkler technical data sheets.



TECHNICAL DATA

**FREEDOM® RESIDENTIAL
SPRINKLER
INSTALLATION GUIDE**

The Viking Corporation, 210 N Industrial Park Drive, Hastings MI 49058
 Telephone: 269-945-9501 Technical Services: 877-384-5464 Fax: 269-818-1680 Email: techsvcs@vikingcorp.com

MINIMUM DISTANCE BETWEEN SPRINKLER AND INTERSECTING SLOPED CEILINGS

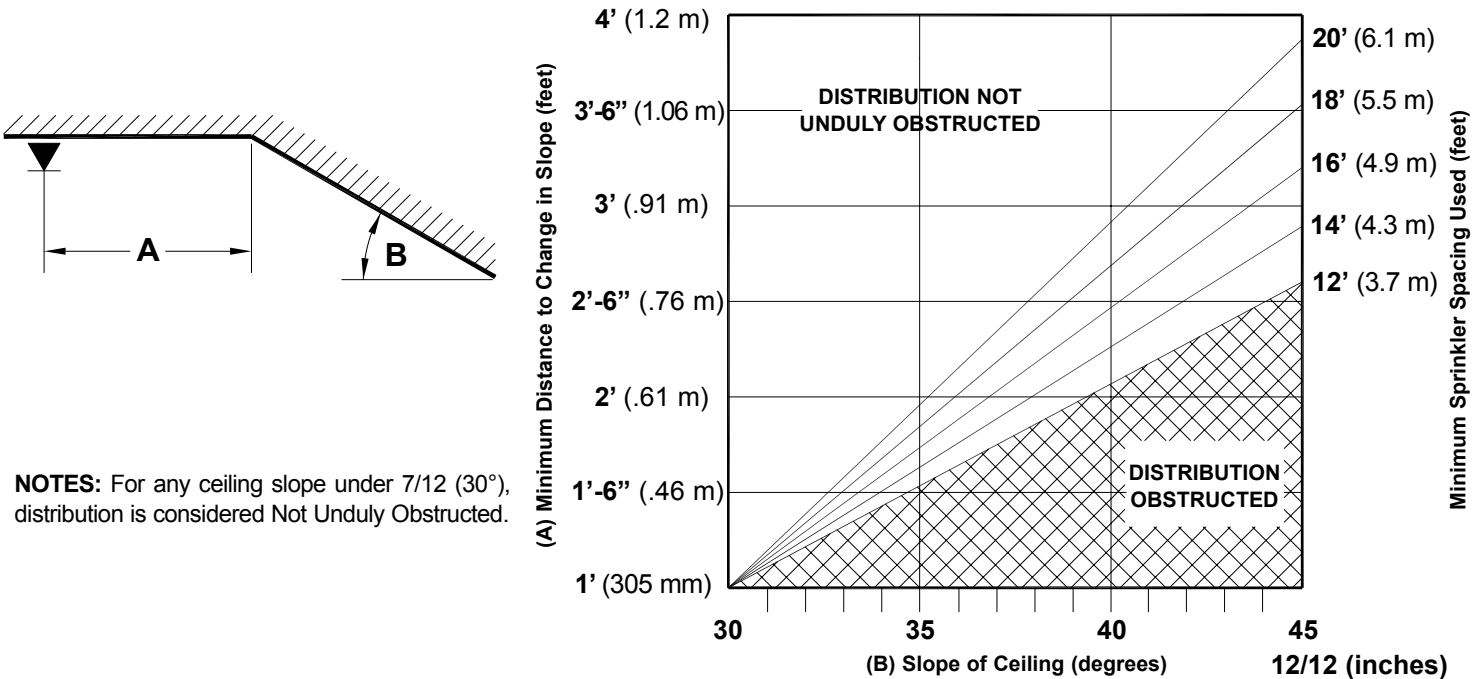

NOTES: For any ceiling slope under 7/12 (30°), distribution is considered Not Unduly Obstructed.

MAXIMUM DISTANCE DOWN SLOPE TO AVOID OBSTRUCTION TO SPRINKLER DISCHARGE

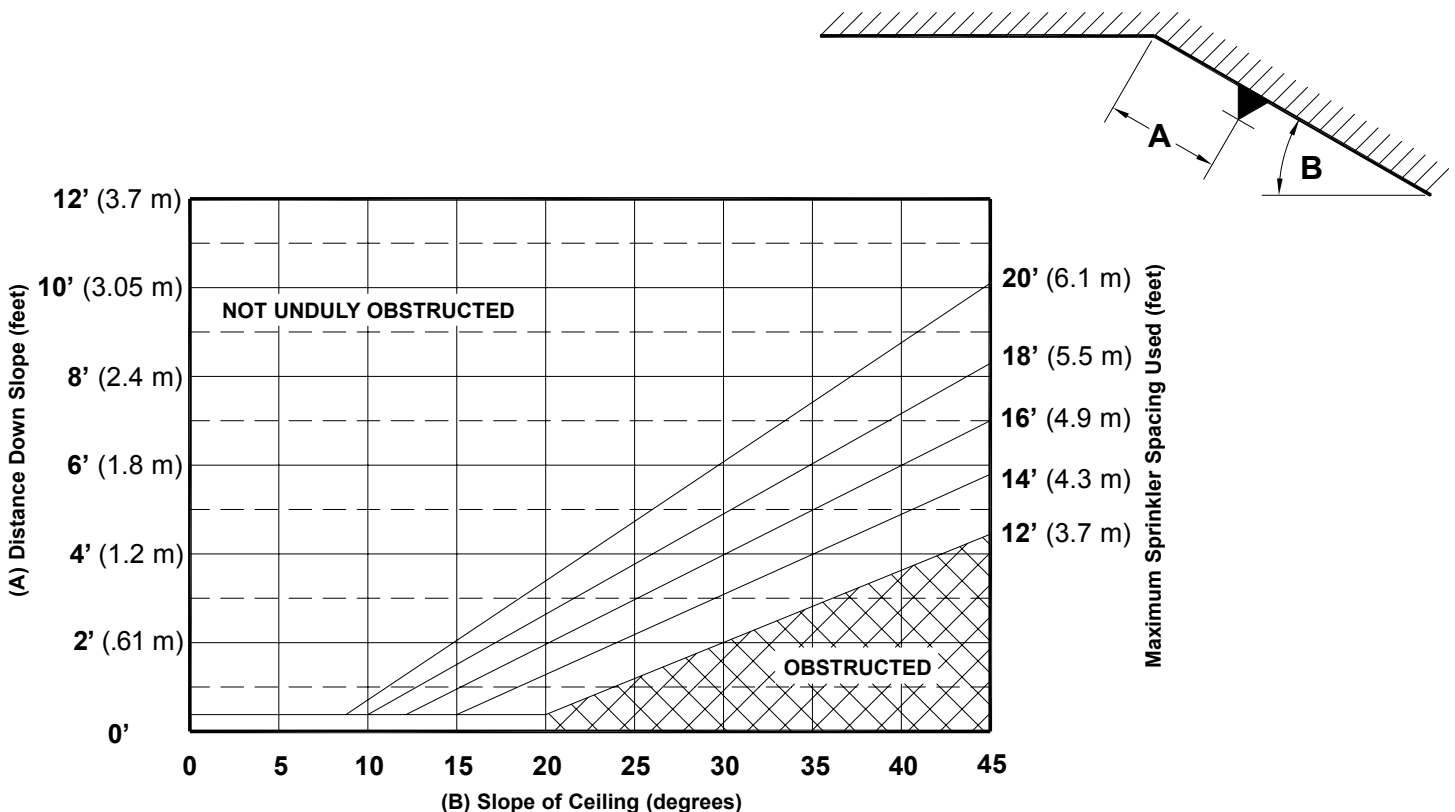



TECHNICAL DATA

**FREEDOM® RESIDENTIAL
SPRINKLER
INSTALLATION GUIDE**

The Viking Corporation, 210 N Industrial Park Drive, Hastings MI 49058
 Telephone: 269-945-9501 Technical Services: 877-384-5464 Fax: 269-818-1680 Email: techsvcs@vikingcorp.com

AVOIDING OBSTRUCTIONS TO SPRINKLER DISCHARGE

(Obstruction rules for residential sprinklers are found in section 8.10 of the 2010 edition of NFPA 13.)

Positioning Residential Pendent Sprinklers - Obstructions at the Ceiling

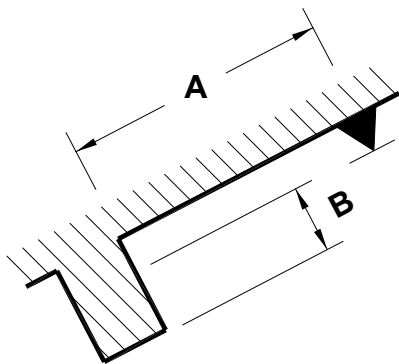
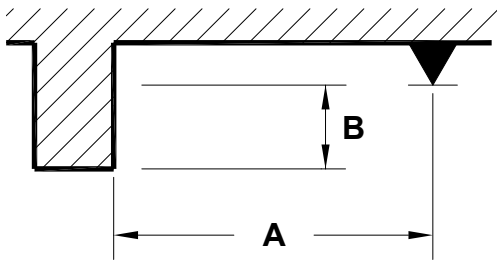

Distance from Sprinkler to Side of Ceiling Obstruction (Dimension A)	Maximum Distance from Deflector to Bottom of Ceiling Obstruction (Dimension B)	
	Inches	mm
Less than 1 ft. 6 in. (Less than 457 mm)	0	0
1 ft. 6 in. to less than 3 ft. (457 mm to less than .94 m)	1	25.4
3 ft. to less than 4 ft. (.91 m to less than 1.2 m)	3	76
4 ft. to less than 4 ft. 6 in. (1.2 m to less than 1.37 m)	5	127
4 ft. 6 in. to less than 6 ft. (1.37 m to less than 1.8 m)	7	178
6 ft. to less than 6 ft. 6 in. (1.8 m to less than 2 m)	9	229
6 ft. 6 in. to less than 7 ft. (2 m to less than 2.1 m)	11	279
7 ft. or greater (2.1 m or greater)	14	356

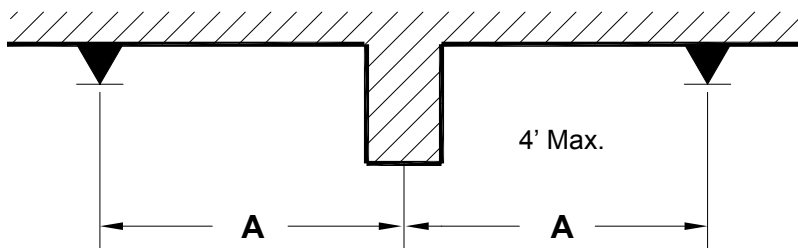

Residential pendent sprinklers may be located on opposite sides of continuous obstructions up to 4 ft. (1.2 m) wide at the ceiling, as long as the distance from the centerline of the obstruction to the sprinklers (A) does not exceed one-half the maximum spacing allowed between sprinklers.

Positioning Residential Pendent Sprinklers - Obstructions Along Walls

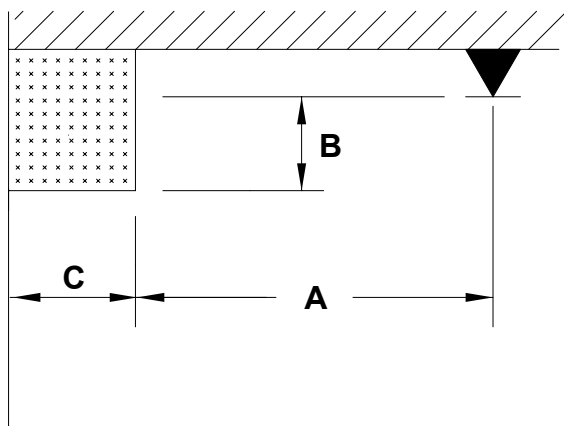

- (A) Distance from centerline of sprinkler to side of obstruction.
- (B) Distance from deflector to bottom of obstruction.
- (C) Width of the obstruction.

Obstructions up to 30 in. (.8 m) wide (C) located against the wall are permitted to be protected when (A) is greater than or equal to (C) minus 8 in. (.2 m) plus (B).

$$C \leq 30 \text{ in.} \quad \text{for metric } C \leq .8 \text{ m}$$

$$A \geq (C - 8 \text{ in.}) + B \quad A \geq (C - .2 \text{ m}) + B$$

	TECHNICAL DATA	FREEDOM® RESIDENTIAL SPRINKLER INSTALLATION GUIDE
---	-----------------------	--

The Viking Corporation, 210 N Industrial Park Drive, Hastings MI 49058
 Telephone: 269-945-9501 Technical Services: 877-384-5464 Fax: 269-818-1680 Email: techsvcs@vikingcorp.com

AVOIDING OBSTRUCTIONS TO SPRINKLER DISCHARGE

(Obstruction rules for residential sprinklers are found in section 8.10 of the 2010 edition of NFPA 13.)

Positioning Residential Horizontal Sidewall Sprinklers - Obstructions at the Ceiling

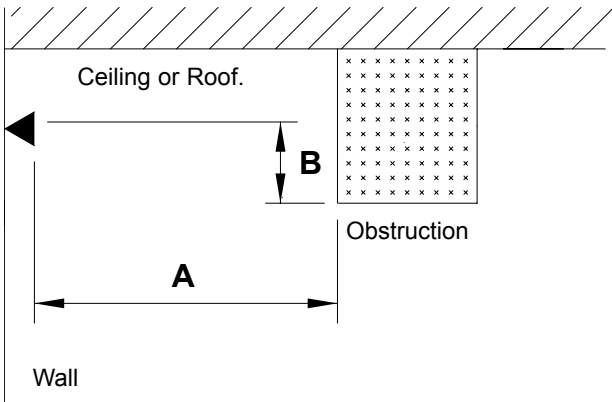

(A) Distance from sprinkler to side of obstruction.
 (B) Distance from deflector to bottom of obstruction.

Distance from Sprinkler to Side of Ceiling Obstruction (Dimension A)	Maximum Distance from Deflector to Bottom of Ceiling Obstruction (Dimension B)	
	Inches	mm
Less than 8 ft. (Less than 2.4 m)	No Obstructions Allowed	
8 ft. to less than 10 ft. (2.4 m to less than 3.05 m)	1	25.4
10 ft. to less than 11 ft. (3.05 m to less than 3.35 m)	2	50.8
11 ft. to less than 12 ft. (3.35 m to less than 3.7 m)	3	76
12 ft. to less than 13 ft. (3.7 m to less than 4 m)	4	102
13 ft. to less than 14 ft. (4 m to less than 4.3 m)	6	152
14 ft. to less than 15 ft. (4.3 m to less than 4.6 m)	7	178
15 ft. to less than 16 ft. (4.6 m to less than 4.9 m)	9	229
16 ft. to less than 17 ft. (4.9 m to less than 5.2 m)	11	279
17 ft. or greater (5.2 m or greater)	14	356

Positioning Residential Horizontal Sidewall Sprinklers - Obstructions Along Walls

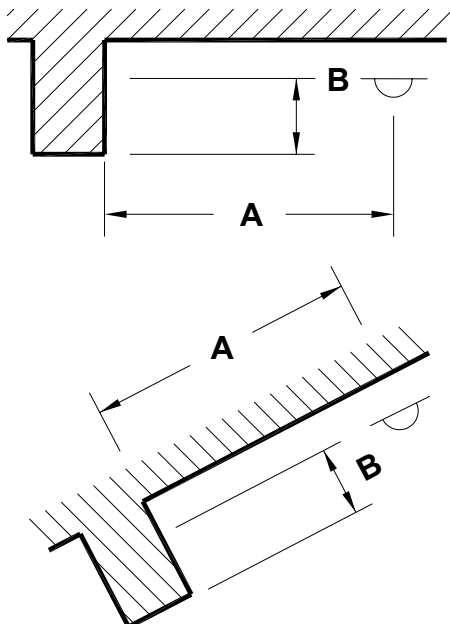

Distance from Sprinkler to Side of Obstruction Along Wall (Dimension A)	Maximum Distance from Deflector to Bottom of Obstruction (Dimension B)	
	Inches	mm
Less than 1 ft. 6 in. (Less than 457 mm)	0	0
1 ft. 6 in. to less than 3 ft. (457 mm to less than .94 m)	1	25.4
3 ft. to less than 4 ft. (.91 m to less than 1.2 m)	3	76
4 ft. to less than 4 ft. 6 in. (1.2 m to less than 1.37 m)	5	127
4 ft. 6 in. to less than 6 ft. (1.37 m to less than 1.8 m)	7	178
6 ft. to less than 6 ft. 6 in. (1.8 m to less than 2 m)	9	229
6 ft. 6 in. to less than 7 ft. (2 m to less than 2.1 m)	11	279
7 ft. or greater (2.1 m or greater)	14	356

(A) Distance from sprinkler to side of obstruction.
 (B) Distance from deflector to bottom of obstruction.



TECHNICAL DATA

FREEDOM® RESIDENTIAL SPRINKLER INSTALLATION GUIDE

The Viking Corporation, 210 N Industrial Park Drive, Hastings MI 49058

Telephone: 269-945-9501 Technical Services: 877-384-5464 Fax: 269-818-1680 Email: techsvcs@vikingcorp.com

LOCATING RESIDENTIAL SPRINKLERS NEAR HEAT SOURCES

Ordinary temperature rated residential sprinklers (135 °F to 170 °F rated) are only to be installed where the maximum ambient ceiling temperature will not exceed 100 °F. Where the maximum ambient ceiling temperature will be from 101 °F to 150 °F, use intermediate temperature rated residential sprinklers (175 °F to 225 °F rated).

Residential sprinklers must be positioned a sufficient distance away from heat sources that include fireplaces, stoves, kitchen ranges, wall ovens, hot water pipes, water heaters, furnaces and associated flues and ducts, and light fixtures. The following minimum distances must be maintained for both ordinary and intermediate temperature rated residential sprinklers as indicated.

Heat Source	Minimum Distance from Edge of Source to Ordinary Temperature Rated Sprinkler		Minimum Distance from Edge of Source to Intermediate Temperature Rated Sprinkler	
	Inches	metric	Inches	metric
Side of open or recessed fireplace	36	.91 m	12	305 mm
Front of recessed fire place	60	1.5 m	36	.91 m
Coal- or wood-burning stove	42	1.1 m	12	305 mm
Kitchen range	18	457 mm	9	229 mm
Wall oven	18	457 mm	9	229 mm
Hot air flues	18	457 mm	9	229 mm
Uninsulated heat ducts	18	457 mm	9	229 mm
Uninsulated hot water pipes	12	305 mm	6	152 mm
Side of ceiling- or wall-mounted hot air diffusers	24	.61 m	12	305 mm
Front of wall-mounted hot air diffusers	36	.91 m	18	457 mm
Hot water heater or furnace	6	152 mm	3	76 mm
Light fixture less than 250W	6	152 mm	3	76 mm
Light fixture 250W to 499W	12	305 mm	6	152 mm
Where residential sprinklers will be exposed to the rays of the sun passing through glass or plastic skylights, use intermediate temperature rated sprinklers.				
When locating residential sprinklers in an unventilated concealed compartment, under an unventilated attic or uninsulated roof, where the maximum ambient temperature does not exceed 150 °F, use intermediate temperature rated sprinklers.				



TECHNICAL DATA

**FREEDOM® RESIDENTIAL
SPRINKLER
INSTALLATION GUIDE**

The Viking Corporation, 210 N Industrial Park Drive, Hastings MI 49058

Telephone: 269-945-9501 Technical Services: 877-384-5464 Fax: 269-818-1680 Email: techsvcs@vikingcorp.com

NOTE: The dimensions shown are intended to apply to residential sprinklers installed in ceilings above fireplaces used to burn products that cause elevated temperatures at or near the ceiling in areas surrounding the fireplace. The recommendations should not be construed to apply to decorative non-opening fireplaces such as gas fire units that will not cause elevated temperatures at the ceiling.

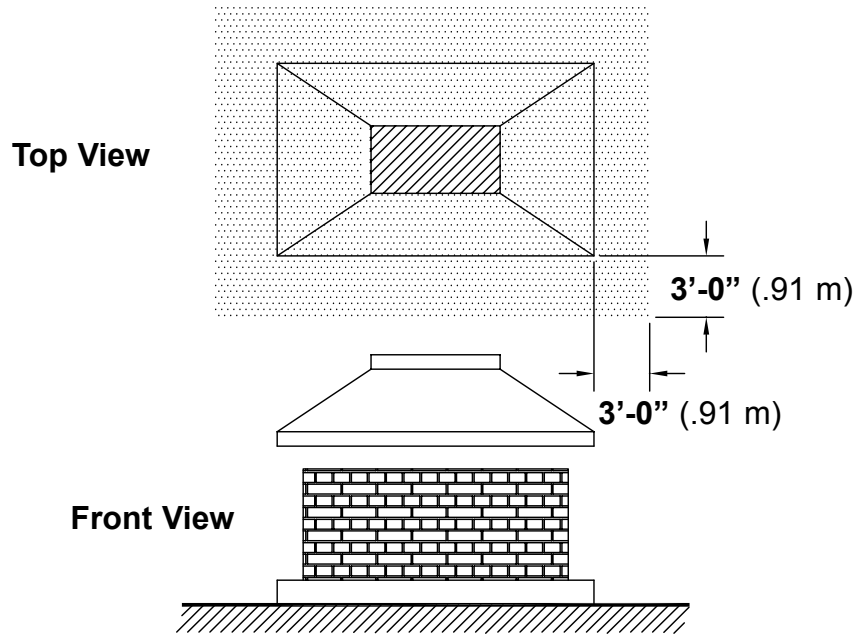

Sprinklers near an open hearth fireplace must be located outside of the shaded area or be intermediate degree rated.

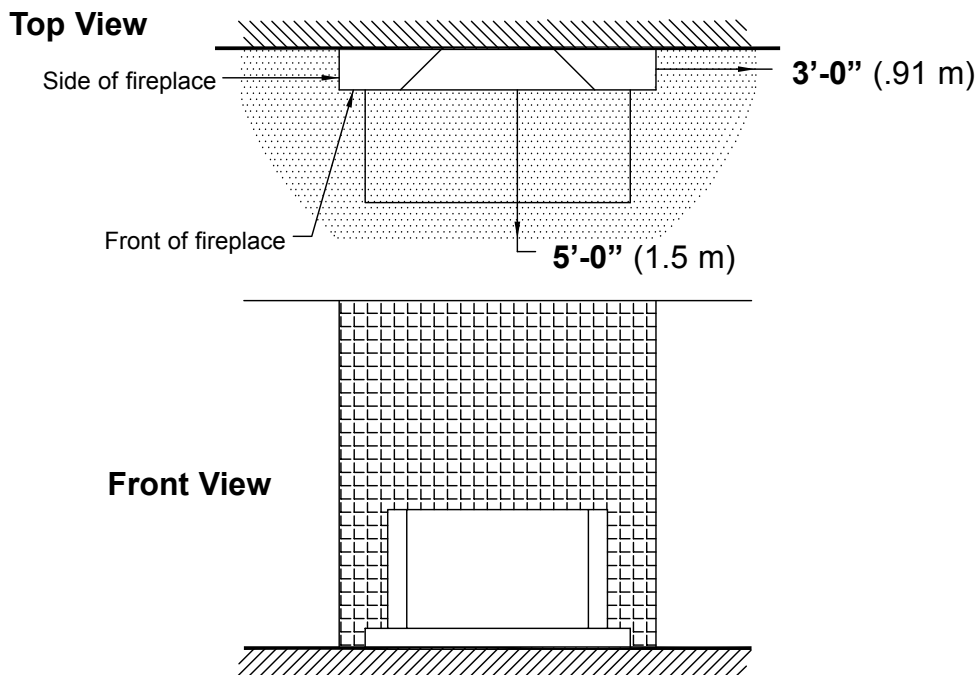

Sprinklers near a recessed hearth fireplace must be located outside of the shaded area [at least 3'-0" (.91 m) from the side of a recessed fireplace and at least 5'-0" (1.5 m) from the front] or be intermediate degree rated.



TECHNICAL DATA

**FREEDOM® RESIDENTIAL
SPRINKLER
INSTALLATION GUIDE**

The Viking Corporation, 210 N Industrial Park Drive, Hastings MI 49058
 Telephone: 269-945-9501 Technical Services: 877-384-5464 Fax: 269-818-1680 Email: techsvcs@vikingcorp.com

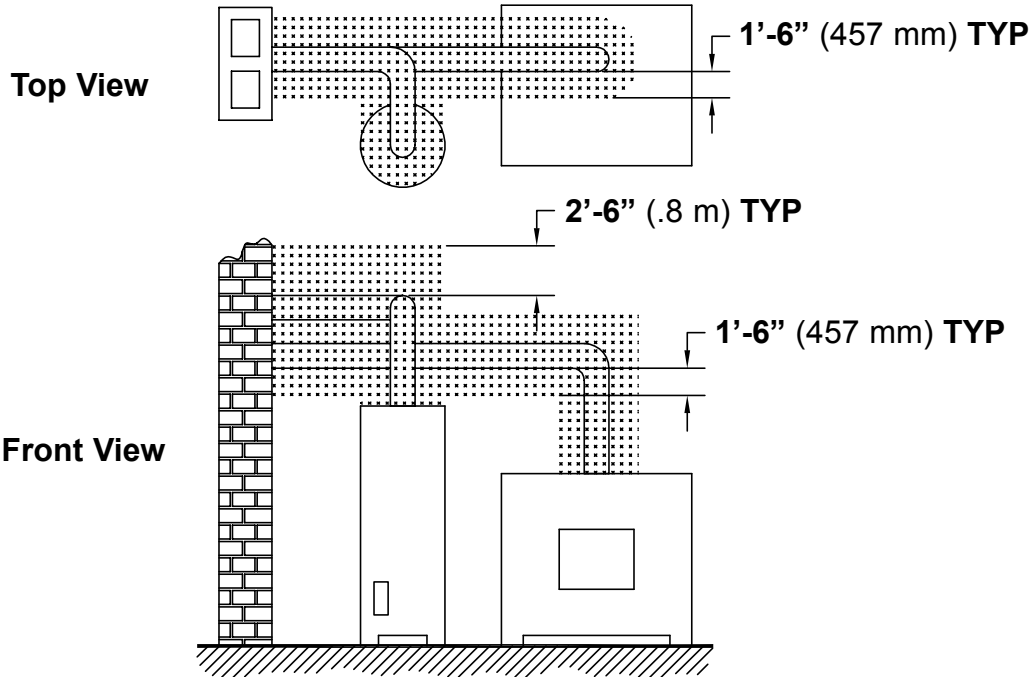

Sprinklers near a furnace or water heater must be located outside of the shaded area or be intermediate degree rated.

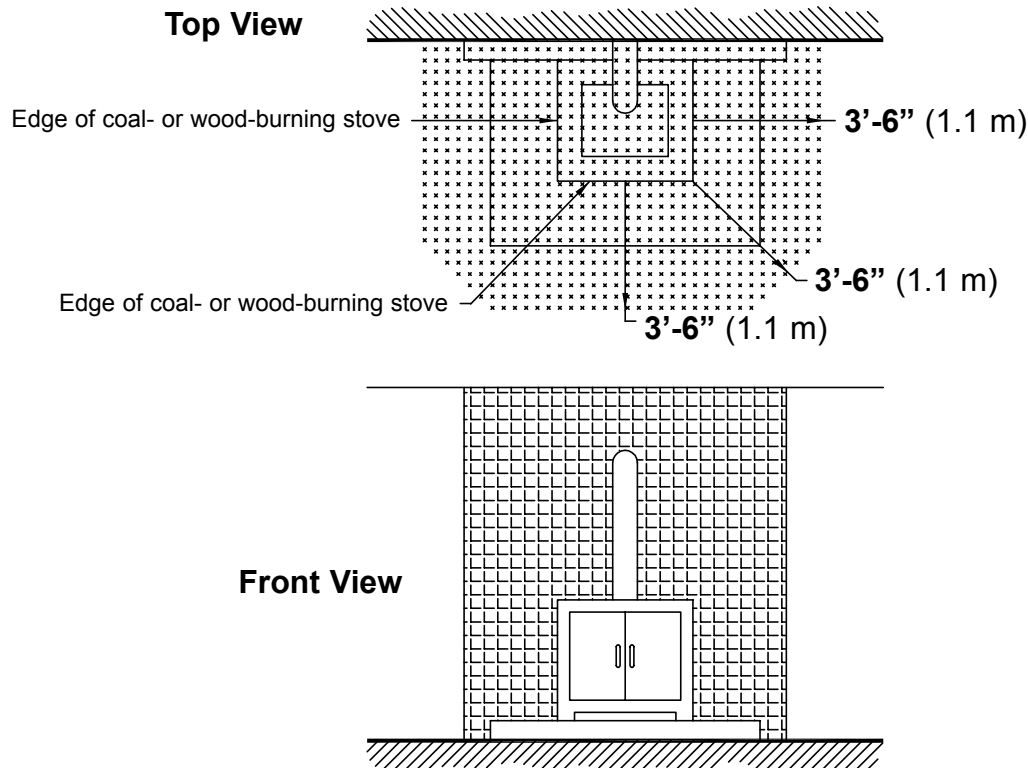

Sprinklers near a coal- or wood-burning stove must be located outside of shaded area or be intermediate degree rated.



TECHNICAL DATA

FREEDOM® RESIDENTIAL
SPRINKLER
INSTALLATION GUIDE

The Viking Corporation, 210 N Industrial Park Drive, Hastings MI 49058
Telephone: 269-945-9501 Technical Services: 877-384-5464 Fax: 269-818-1680 Email: techsvcs@vikingcorp.com

Top View

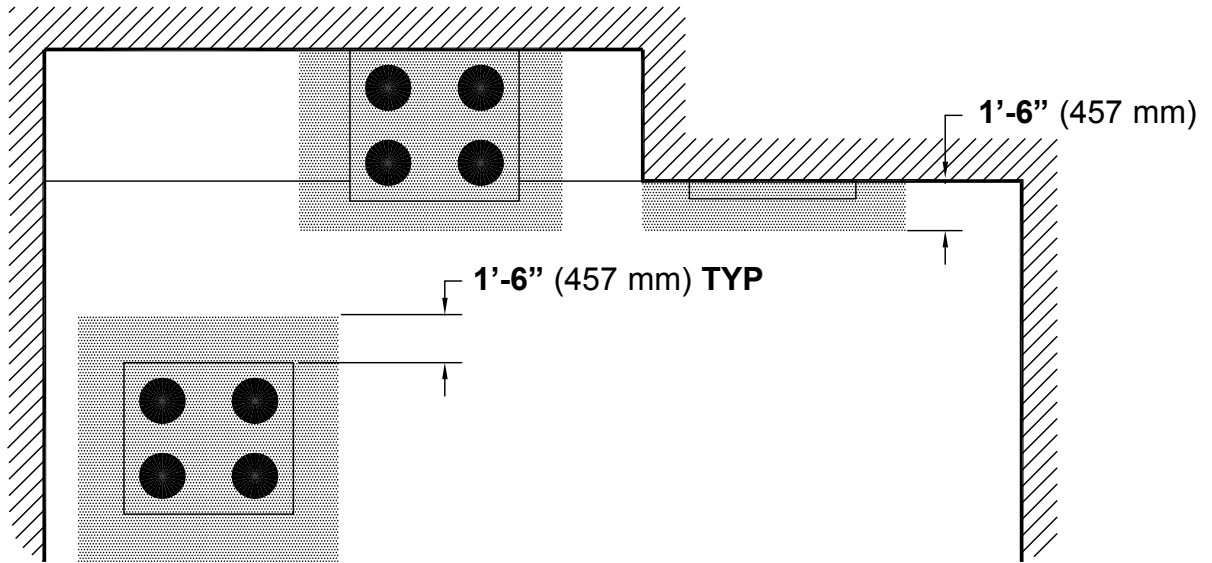

Front View

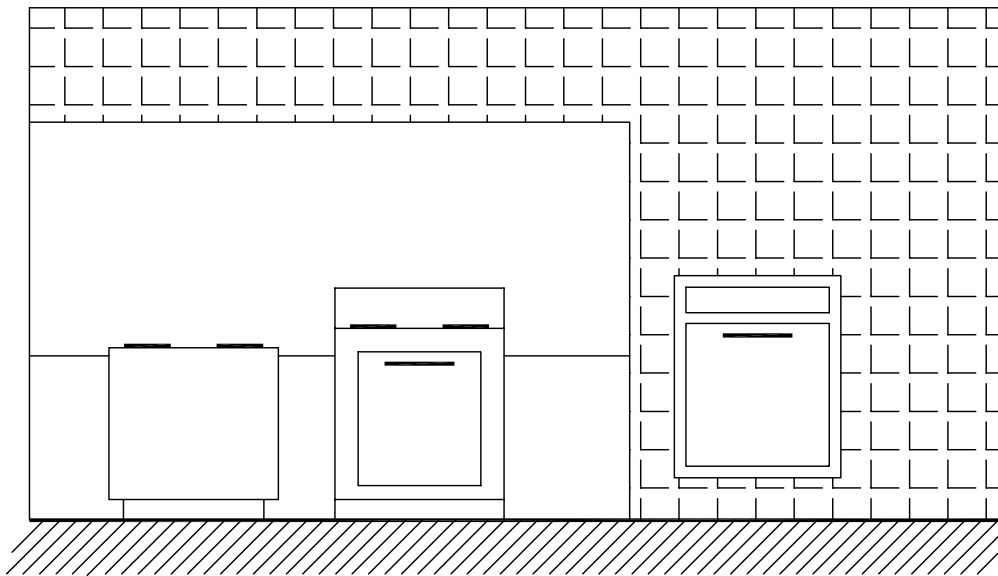

Sprinklers near a range or wall oven must be located outside of shaded areas or be intermediate degree rated.