



## TECHNICAL DATA

### CONCENTRATE CONTROL VALVE APPLICATIONS, PRIMING CONNECTIONS, AND TRIMS

The Viking Corporation, 210 N Industrial Park Drive, Hastings MI 49058

Telephone: 269-945-9501 Technical Services: 877-384-5464 Fax: 269-818-1680 Email: techsvcs@vikingcorp.com

Visit the Viking website for the latest edition of this technical data page [www.vikinggroupinc.com](http://www.vikinggroupinc.com)

## 1. GENERAL DESCRIPTION

The Halar® Coated Concentrate Control Valve (CCV) is utilized in Viking foam systems as a positive shut-off valve for the foam concentrate supplied either from a bladder tank or a foam pump. The CCV valve opens automatically when there is a water flow in the sprinkler system. This allows concentrate to flow through the proportioning device to create foam solution.

### A. Standard Foam Deluge, Foam Preaction, and Foam Flow Control Systems (See Figure 4)

The CCV valve is a straight through Halar® coated deluge. The priming connection can be part of the riser control valve trim, (conventional deluge or flow control trim). When the priming connection to the CCV is located on the primary riser valve trim, the priming supply connection to the CCV is located prior to the release trim. The actual supply inlet to the CCV should be connected to an open connection port on the cover of the deluge or flow control valve. The 1/2" pipe plugs installed in the cover of the deluge or flow control valve may be removed and piping from the valve cover can be connected to the priming chamber of the CCV or an outlet can be created prior to the release device (solenoid or pneumatic actuator) on the valve trim. When the deluge or flow control valve activates, the priming water in the deluge or flow control valve and the CCV are released simultaneously allowing both valves to open. Priming water pressure will be drained through the deluge or flow control valve trim. The valves will remain open until the system is reset. Refer to design data pages for re-setting instructions.

### B. Wet Foam Systems (See Figure 3)

The CCV valve is a straight through Halar® coated deluge or flow control valve. Where the CCV is used in conjunction with a wet foam system a separate primary priming connection is required. The separate priming connection will consist of a 1/2" ball valve, 1/2" "Y" strainer, 1/8" restricted orifice, 1/2" spring loaded check valve, and Pressure Operated Relief Valve (PORV). The priming water supply to the CCV is taken upstream of the riser control valve. The priming supply feeds through the system to the priming chamber of the CCV. The sensing side of the PORV is connected to the alarm connection of the Alarm Valve. When water flow is present through the sprinkler riser, water flows from the alarm connection to the sensing side of the PORV, the PORV opens which drains the CCV priming chamber allowing it to open. Foam concentrate will discharge from the CCV to the proportioning device until water pressure is removed from the sensing side of the PORV. Note that the PORV 1/2" drain will operate when the system is activated. The PORV must be piped to an open drain.

## 2. LISTINGS AND APPROVALS

UL Listed - Deluge Valve EX2006

FM Approved - FM5130, 1020

LPCB

Refer to the individual technical data sheets for the components within the system.

## 3. TECHNICAL DATA

### 3.1 Specifications:

Refer to individual component technical data pages for PORV, Pressure Switch, Solenoid Valve, and Deluge Valves.

### 3.2 Material Standards:

Refer to individual component technical data page.

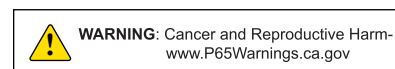



# TECHNICAL DATA

## CONCENTRATE CONTROL VALVE APPLICATIONS, PRIMING CONNECTIONS, AND TRIMS

The Viking Corporation, 210 N Industrial Park Drive, Hastings MI 49058  
 Telephone: 269-945-9501 Technical Services: 877-384-5464 Fax: 269-818-1680 Email: techsvcs@vikingcorp.com  
 Visit the Viking website for the latest edition of this technical data page www.vikinggroupinc.com

### 3.3 Ordering Information:

**Table 3.3.1: Ordering Information**

HALAR® COATED CONCENTRATE CONTROL VALVES											TRIM KIT PART NUMBERS	
Valve Style	Valve Model	Deluge Part No.	Valve Size Nominal	Inlet Type	Outlet Type	Pipe O.D. Actual	Flange Drilling	Friction Loss*	Cv Factor	Shipping Weight	Galvanized & Brass	Brass only
Straight Through	F-2	12127Q/B	1½" (DN40)	Grooved	Grooved	1 <sup>29</sup> / <sub>32</sub> " (48.3 mm)	--	7 ft. (2.1 m)	66	36 lbs. (16.3 kg)	12848-1	12848-2
	F-2	12058Q/B	2" (DN50)	Grooved	Grooved	2 <sup>3</sup> / <sub>8</sub> " (60.3 mm)	--	13 ft. (3.9 m)	93	36.5 (16.5 kg)	12848-1	12848-2
	F-2	12404Q/B	2½" (DN65)	Grooved	Grooved	2 <sup>7</sup> / <sub>8</sub> " (73 mm)	--	12 ft. (3.6 m)	155	66 lbs. (30 kg)	12929-1	12929-2
	F-2	12730Q/B	DN65	Grooved	Grooved	76 mm	--	12 ft. (3.6 m)	155	66 lbs. (30 kg)		
	F-2	12015Q/B	3" (DN80)	Flanged	Flanged	3½" (88.9 mm)	ANSI B16.42 Class 150	12 ft. (3.6 m)	228	82 lbs. (37 kg)		
	F-2	12019Q/B	3" (DN80)	Flanged	Grooved	3½" (88.9 mm)	ANSI B16.42 Class 150	12 ft. (3.6 m)	228	73 lbs. (33.1 kg)		
	F-2	12023Q/B	3" (DN80)	Grooved	Grooved	88.9 mm		12 ft. (3.6 m)	228	64 lbs. (29 kg)		

\* Expressed in equivalent length of pipe based on Hazen & Williams Formula C=120.

## 4. INSTALLATION

Refer to specific technical data sheets, acceptable installation standards, codes and Authority Having Jurisdiction for additional installation, operation and maintenance instructions.

## 5. OPERATION

Refer to individual component technical data page.

## 6. INSPECTIONS, TESTS AND MAINTENANCE

### NOTICE

The owner is responsible for maintaining the fire protection system and devices in proper operating condition. For minimum maintenance and inspection requirements, refer to recognized standards such as those produced by NFPA, LPC, and VdS which describe care and maintenance of sprinkler systems. In addition, the Authority Having Jurisdiction may have additional maintenance, testing and inspection requirements which must be followed.

### ⚠ WARNING

Any system maintenance or testing that involves placing a control valve or detection system out of service may eliminate the fire protection of that system. Prior to proceeding, notify all Authorities Having Jurisdiction. Consideration should be given to employment of a fire patrol in the affected area.

It is imperative that the system is inspected and tested on a regular basis. The frequency of the inspections may vary due to contaminated or corrosive water supplies and corrosive atmospheres. In addition, the alarm devices or other connected equipment may require more frequent inspections. Refer to the technical data, system description, applicable codes and Authority Having



## TECHNICAL DATA

### CONCENTRATE CONTROL VALVE APPLICATIONS, PRIMING CONNECTIONS, AND TRIMS

The Viking Corporation, 210 N Industrial Park Drive, Hastings MI 49058

Telephone: 269-945-9501 Technical Services: 877-384-5464 Fax: 269-818-1680 Email: techsvcs@vikingcorp.com

Visit the Viking website for the latest edition of this technical data page [www.vikinggroupinc.com](http://www.vikinggroupinc.com)

Jurisdiction for minimum requirements.

## 7. AVAILABILITY

The product is available directly from Viking and official distributors only.

### Americas:

The Viking Corporation  
5150 Beltway SE  
Caledonia, MI 49316  
Tel.: (800) 968-9501  
Fax: 269-818-1680  
Technical Services: 1-877-384-5464  
[techsvcs@vikingcorp.com](mailto:techsvcs@vikingcorp.com)

### EU:

Viking S.A.  
21, Z.I. Haneboesch  
L-4562 Differdange / Nieder Korn  
Tel.: +352 58 37 37 - 1  
Fax: +352 58 37 36  
[vikinglux@viking-emea.com](mailto:vikinglux@viking-emea.com)

### Asia Pacific (APAC) Main Office:

The Viking Corporation (Far East) Pte. Ltd.  
69 Tuas View Square  
Westlink Techpark, Singapore 637621  
Tel: (+65) 6 278 4061  
Fax: (+65) 6 278 4609  
[vikingAPAC@vikingcorp.com](mailto:vikingAPAC@vikingcorp.com)

## 8. GUARANTEE

For details of warranty, refer to Viking's current list price schedule or contact Viking directly.

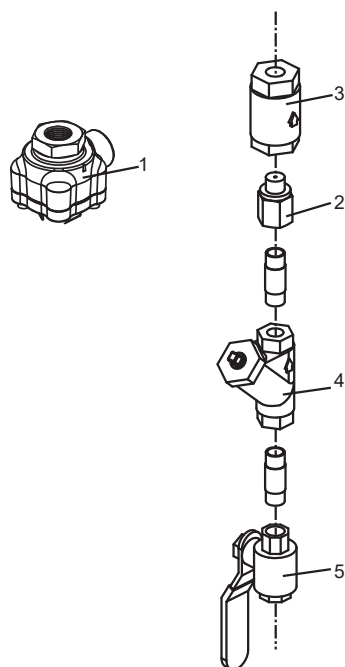

**Table 2: Priming Line Connection Package (PN 10985) Components**

REF.	DESCRIPTION
1	1/2" Pressure Operated Relief Valve (PORV)
2	1/8" Restricted Orifice
3	1/2" Swing Check Valve
4	1/2" Y-Strainer
5	1/2" Ball Valve

**Figure 1 - Priming Connection Package Components**

**NOTE:** All components shown here are included with the Priming Connection Package (PN 10985)



# TECHNICAL DATA

## CONCENTRATE CONTROL VALVE APPLICATIONS, PRIMING CONNECTIONS, AND TRIMS

The Viking Corporation, 210 N Industrial Park Drive, Hastings MI 49058  
 Telephone: 269-945-9501 Technical Services: 877-384-5464 Fax: 269-818-1680 Email: techsvcs@vikingcorp.com  
 Visit the Viking website for the latest edition of this technical data page www.vikinggroupinc.com

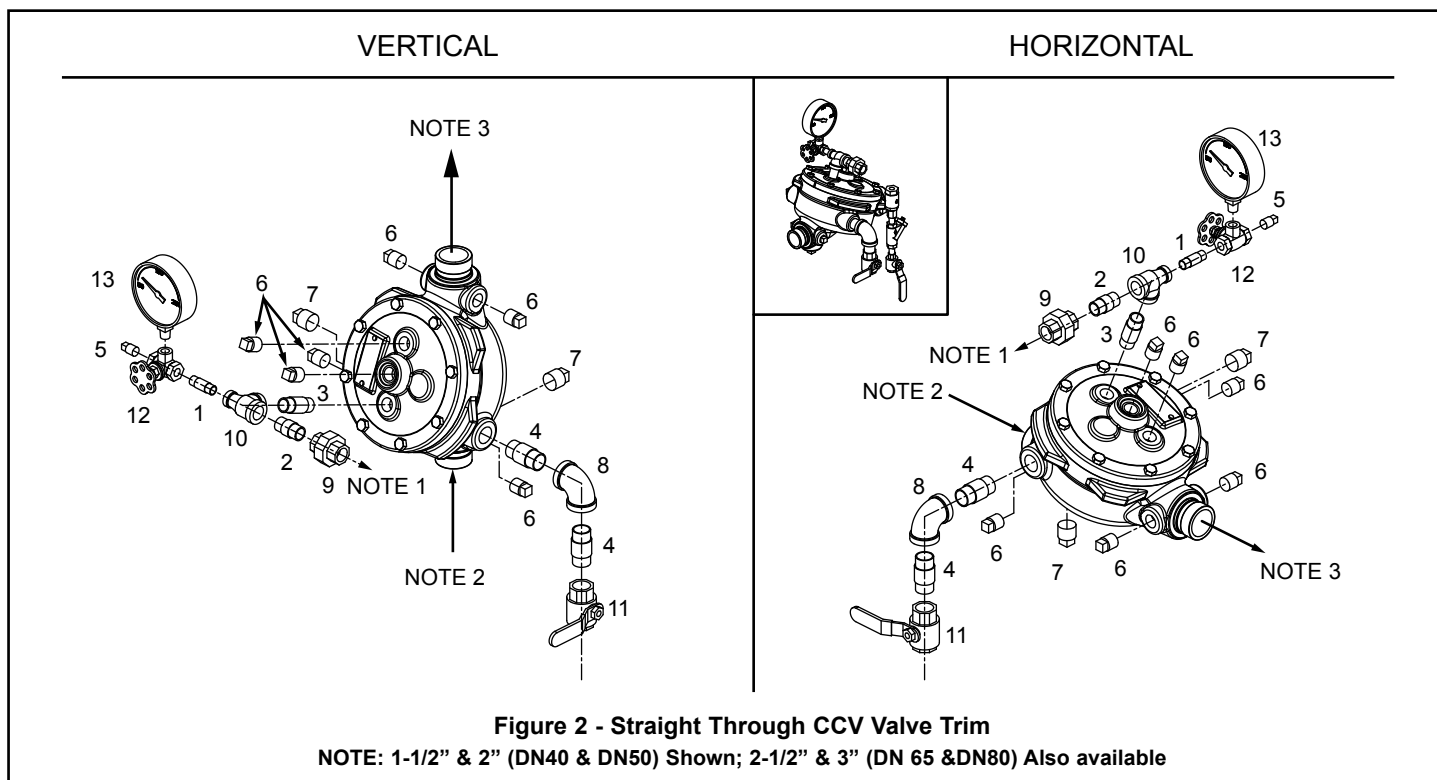

**Table 1: CCV and Trim Components and Material Identification**

REF.	SIZE (INCH)	DESCRIPTION	MATERIAL	
			G = Galvanized, B = Brass, ST = Stainless steel	
			On Galvanized Trim	On Brass Trim
1	1/4 X 1-1/2	NIPPLE	G	B
2	1/2 X 1-1/2	NIPPLE	G	B
3	1/2 X 2	NIPPLE	G	B
4	3/4 X 2	NIPPLE	B	B
5	1/4	PLUG	G	B
6	1/2	1/2 PLUG	ST	B
7	3/4	3/4 PLUG	B	B
8	3/4	3/4 ELBOW	B	B
9	1/2	1/2 UNION	G	B
10	1/2 X 1/4 X 1/2	TEE	G	B
11	3/4	SHUTOFF VALVE	-	-
12	1/4	SIDE OUTLET VALVE	-	-
13	1/4-	WATER GAUGE	-	-

Note 1: Field pipe to hydraulic release of system control valve or PORV as determined by system type.

Note 2: Foam concentrate inlet from bladder tank.

Note 3: To foam proportioner device.



# TECHNICAL DATA

## CONCENTRATE CONTROL VALVE APPLICATIONS, PRIMING CONNECTIONS, AND TRIMS

The Viking Corporation, 210 N Industrial Park Drive, Hastings MI 49058  
 Telephone: 269-945-9501 Technical Services: 877-384-5464 Fax: 269-818-1680 Email: techsvcs@vikingcorp.com  
 Visit the Viking website for the latest edition of this technical data page www.vikinggroupinc.com

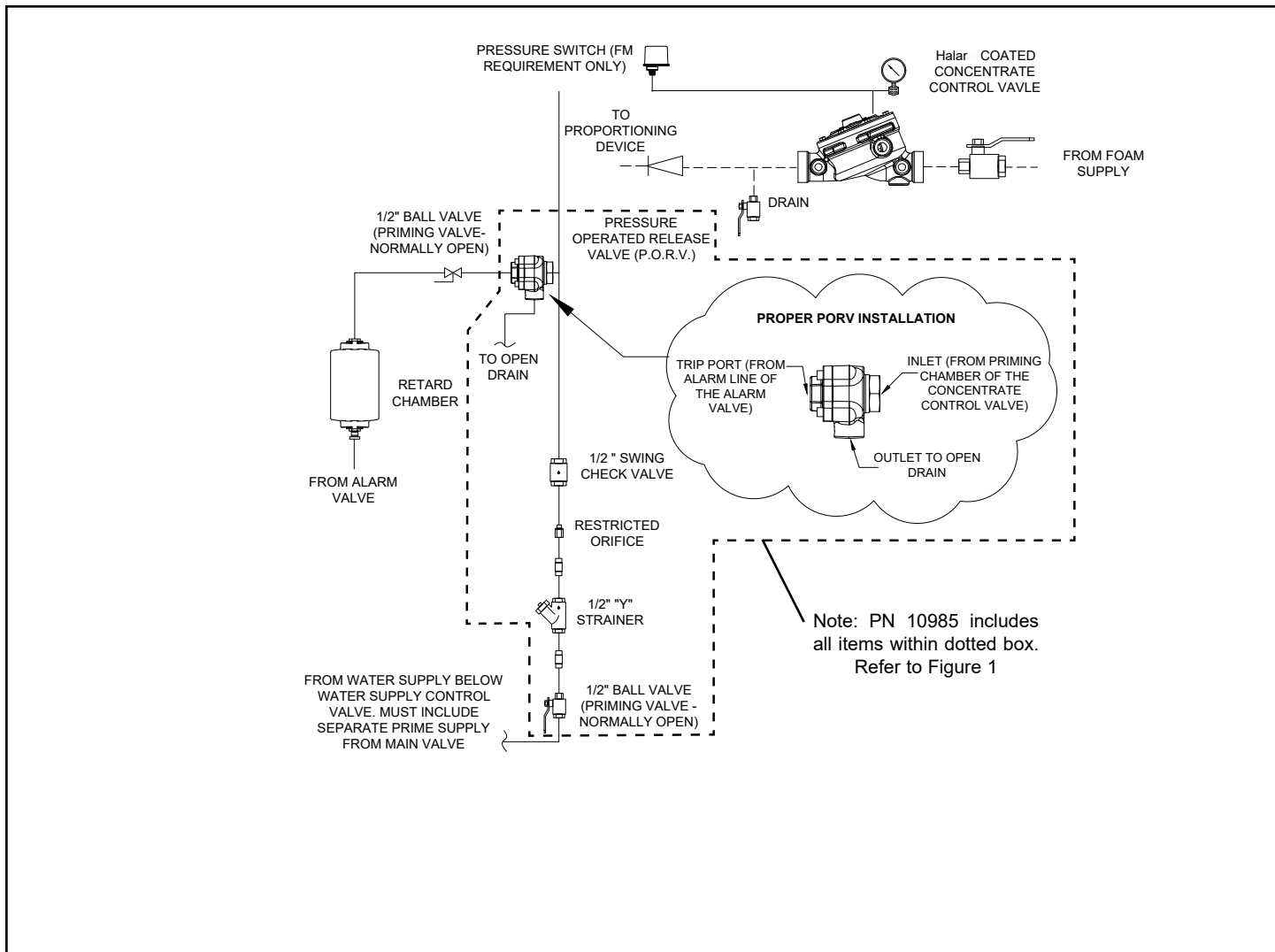

Figure 3 - Wet Pipe Foam Systems



# TECHNICAL DATA

## CONCENTRATE CONTROL VALVE APPLICATIONS, PRIMING CONNECTIONS, AND TRIMS

The Viking Corporation, 210 N Industrial Park Drive, Hastings MI 49058  
 Telephone: 269-945-9501 Technical Services: 877-384-5464 Fax: 269-818-1680 Email: techsvcs@vikingcorp.com  
 Visit the Viking website for the latest edition of this technical data page [www.vikinggroupinc.com](http://www.vikinggroupinc.com)

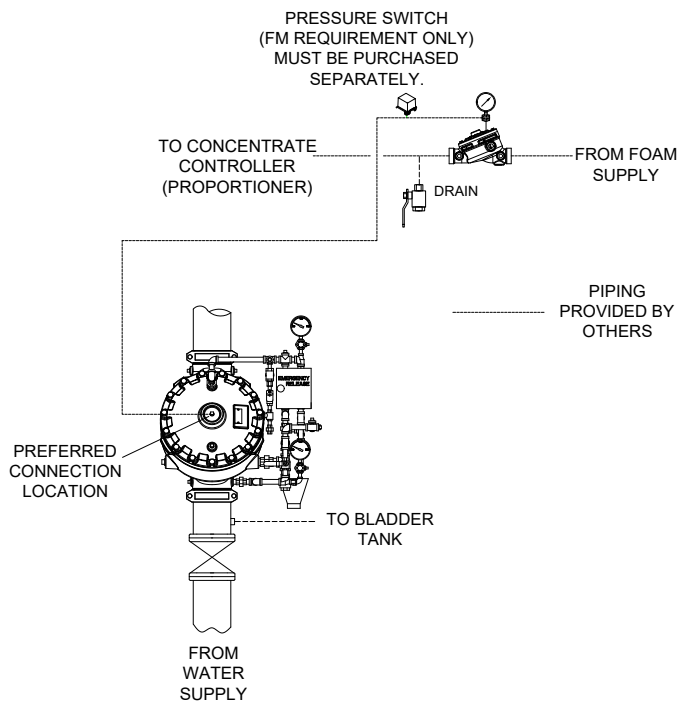

Figure 4 - Deluge and Preaction Systems