

# VFR-500 Conventional Releasing Panel

## Program Templates





## Programming

---

### VFR-500 Standard Program Information

The VFR-500 has 30 standard program templates which are detailed on the following pages. Selecting one of these programs will automatically program every function of the panel except custom zone and banner messages.

NOTE:

The release soak time defaults to continuous for all programs.

In the Agent suppression programs, the pre-discharge timer for detectors defaults to 60 seconds. The pre-discharge timer for manual stations defaults to 30 seconds. The abort mode defaults to UL.

Default programming allows the activation of a zone programmed as, Manual Release, to override any cross zoning and abort to activate the release output it is mapped to. Abort override can be changed in the panel programming by allowing manual release zones to be aborted.

Default programming does not allow zones programmed as Manual Release to be aborted. This can be changed in the panel programming.

### VFR-500 Standard Program Information

Press ENT to enter program mode.

Scroll down to see the various menu options. A blinking arrow  $\longrightarrow$  indicates the current option.

Users can also simply enter the option number. See the Menu Tree for a complete list and location of options

Follow the on-screen instructions

NOTE: Some options have YES/NO selections. Use the up/down arrows to change selection.

To enter one of the standard programs:

1. Press ENT
2. Enter 6 or scroll down to PROGRAMMING, indicated by a flashing  $\longrightarrow$  and press ENT.
3. Enter the password. Factory default password is, 1111.
4. Press 1 OR ENT to select PRORGAM NUMBER.
5. Enter the desired program number
6. Press ENT
7. Press 1 to accept the new program
8. Press ENT to accept the change and update the panel

All zones and outputs are now programmed and all mapping of zones to correlating outputs is complete.

For abort functionality (available in Agent Release Mode only), pre-discharge or soak timers are required, repeat steps 1-3. Then select the desired option and follow the on-screen instructions.

Modifications to standard programs can be easily accomplished using the Viking programming tool.

The following is an explanation of how the various programs operate and information about the types of devices that are to be connected to the input (Initiating) zones and output (NAC) circuits.

If none of the standard programs are acceptable for the operation required, selecting program 0 allows the user to create a custom program. Standard programs can also be modified to create custom programs. Simply select the standard program that is closest to the operation needed. Then selecting program 0 allows the user to make changes to the previously selected program as necessary.

If zone characteristics need to be modified, including latching, output patterns, manual/auto silence behavior. Repeat steps 1-6 above and select program 0. After the panel restarts to edit zone characteristics repeat steps 1-3 and select 6 ZONES.

The water based extinguishing programs are numbered 1-19 and 30-35. The agent extinguishing programs are numbered 20-24.

To enable Class A on zones 3 or 4:

1. Install IDC-6 with address 16 as described on pg. 3-23
2. Press ENT
3. Enter 8 or scroll down to PANEL SETUP, indicated by a flashing → and press ENT
4. Enter the password. Factory default is 1111.
5. Enter 2 or scroll down to LEARN MENU, indicated by a flashing → and press ENT
6. Press 1 OR ENT to select LEARN ALL

The panel will search for connected devices

7. Press 1 or ENT to select P-LINK FOUND to review devices

Addr 16 (IDC-6)

8. Press ESC to exit learn all menu
9. Press 1 to Accept the new devices
10. Press ENT to accept the change and update the panel
11. Press ENT
12. Enter 8 or scroll down to PANEL SETUP, indicated by a flashing → and press ENT
13. Enter the password. Factory default is 1111.
14. Enter 7 or scroll down to IDC6 F/CA ZONE 3, indicated by a flashing → and press ENT
15. Press any key to accept
16. Press ESC to exit PANEL SETUP menu
17. Press 1 to Accept
18. Press ENT to accept the change and update the panel

Repeat steps 11 – 18 using 8 or scroll down to IDC6 F/CA ZONE 4 to enable class A for zone 4. Zone 3 class A wiring to INPUT 3 / INPUT 4 on IDC-6 address 16 as shown on page 3-24. Zone 4 class A wiring to INPUT 5 / INPUT 6 on IDC-6 address 16. When using standard program templets IDC-6 address 16 INPUTS 1 and INPUT 2 are unused.

**Menu Tree**

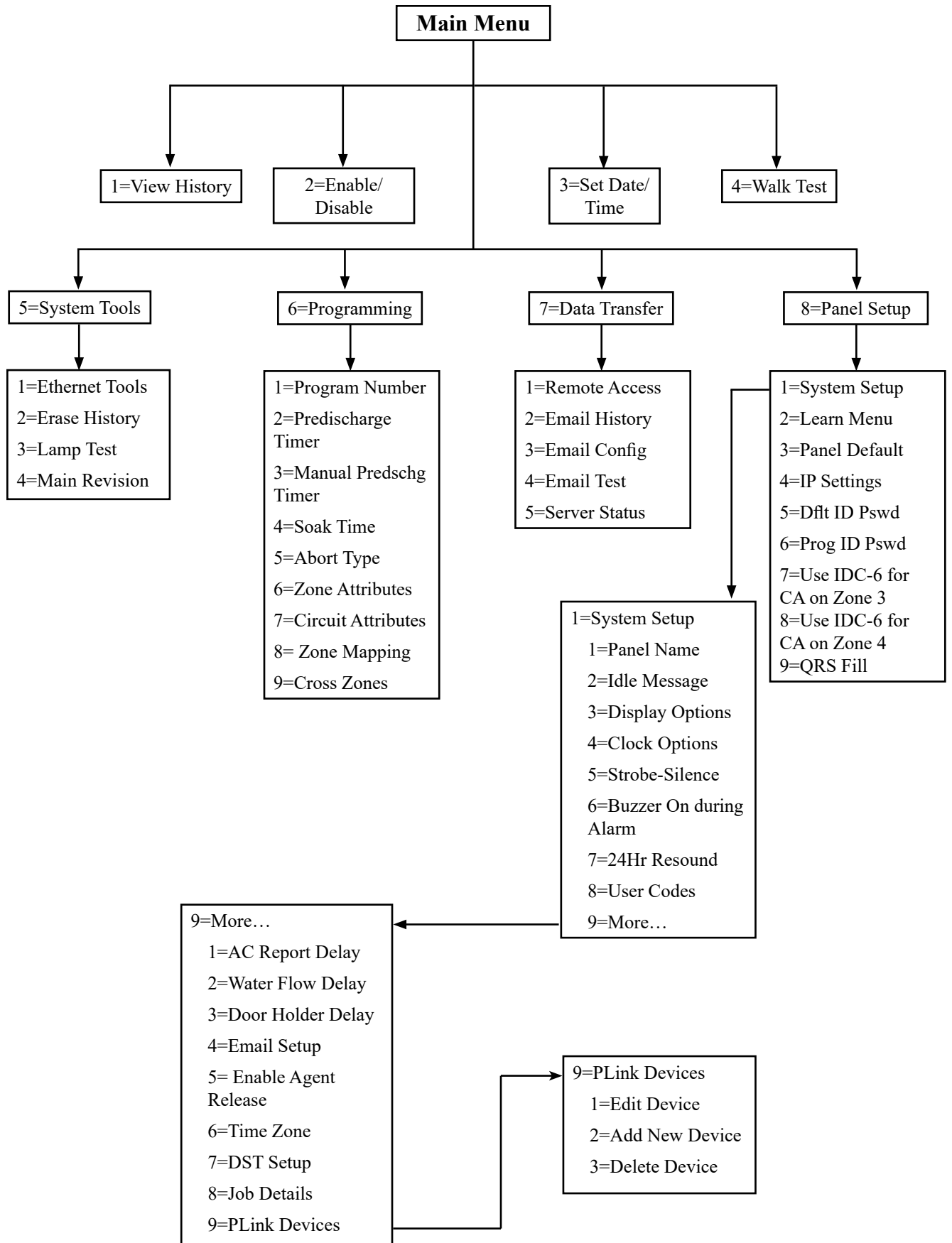

# Wiring Diagram Programs

## PROGRAM #1

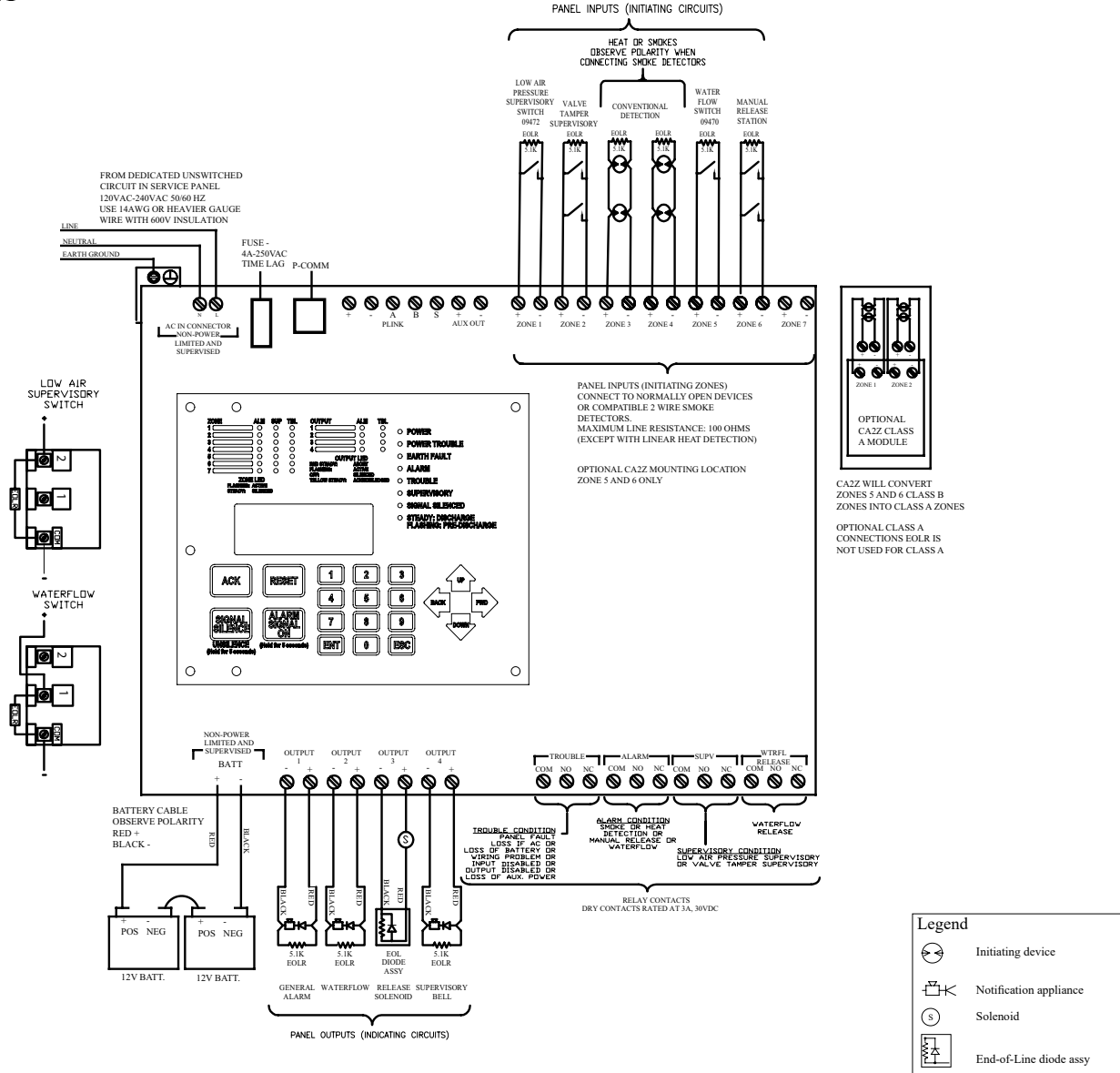

### NOTES:

1. Run field wiring and ensure connections are proper by metering wires. Resistance reading should be 5.1K ohms with end-offline resistor (EOLR) at last device. The end-of-line resistor are supplied with the panel. Install EOLR on all unused circuits.
2. Connect one circuit at a time and apply AC power.
3. Connect batteries to the panel
4. Press ENT to enter PROGRAM mode
5. Press 6 or scroll down to #6 and press ENT, (The selection is indicated by a flashing arrow next to the number.
6. Enter the password. (Factory default is 1111)
7. Press 1 or press ENT. (1 should be the highlighted selection)
8. The display shows the current program number. Press 1 to change to program 1. Press ENT.
9. Press 1 to accept the change.
10. Press ENT to accept the change

| PROGRAM #1                       |   |  |                             |                             |                |                     |        |
|----------------------------------|---|--|-----------------------------|-----------------------------|----------------|---------------------|--------|
| For One Sprinkler System         |   |  |                             |                             |                |                     |        |
| Viking Sprinkler System Types    | 2 Release Zones, Waterflow Zone, & Manual Release Zone  | 1. Single Interlocked Preaction System with Electric Release           |                             |                             |                |                     |        |
|                                  |   | 2. Deluge System with Electric Release                                 |                             |                             |                |                     |        |
|                                  |   | 3. Non-Interlocked Preaction System with Electric Release              |                             |                             |                |                     |        |
|                                  |   | 4. Double Interlocked Preaction System with Electric/Pneumatic Release |                             |                             |                |                     |        |
| OUTPUTS<br>(Indicating Circuits) | ZONES (Initiating Circuits)   |  |                             |                             |                |                     |        |
|                                  | #1  | #2   | #3                          | #4                          | #5             | #6                  | #7     |
|                                  | Low Air Supervisory Zone  | Valve Tamper Supervisory Zone  | Conventional Detection Zone | Conventional Detection Zone | Waterflow Zone | Manual Release Zone | Unused |
| #1 General Alarm                 |   |  | X                           | X                           | X              | X                   |        |
| #2 Waterflow                     |   |  |                             |                             | X              |                     |        |
| #3 Release Solenoid              |   |  | X                           | X                           |                | X                   |        |
| #4 Supervisory Bell              | X   | X  |                             |                             |                |                     |        |
| OPERATION DESCRIPTION            |   |  |                             |                             |                |                     |        |
| Inputs:                          | 2 Conventional Detection zones, 1 Waterflow zone, 1 Manual Release zone, 2 Supervisory zones  |  |                             |                             |                |                     |        |
| Outputs:                         | 1 General Alarm, 1 Waterflow Alarm, 1 Solenoid Release, 1 Supervisory Bell  |  |                             |                             |                |                     |        |
| Operation:                       | Activation of Conventional Detection zone #3 or #4 or Manual Release zone #6 will activate output #3 (Release Solenoid) and output #1 (General Alarm) |  |                             |                             |                |                     |        |
|                                  | Activation of Waterflow zone #5 will activate output #2 (Waterflow) and output #1 (General Alarm)   |  |                             |                             |                |                     |        |
|                                  | Activation of Low Air Supervisory zone #1 or Valve Tamper Supervisory zone #2 will operate output #4 (Supervisory Bell).                              |  |                             |                             |                |                     |        |

**NOTES:**

1. Connect EOL Diode assembly IN SERIES as shown with Solenoid on output #3 (Release Solenoid). Black wire to negative terminal on panel and Red wire through Solenoid to positive terminal on panel.
2. Polarity is shown on indicating circuits in an activated (in alarm) condition.
3. Install EOLR (provided) on all unused circuits.
4. See the instruction manual for circuit information, panel limits, and battery sizing.
5. For wire routing instructions through the releasing panel, see Fig 1 on page 2-7 of the instruction manual.
6. See instruction manual for proper programming.
7. See instruction manual for list of compatible smoke detectors.
8. See specific system type data page for proper pressure switch settings.

**PROGRAM #2**

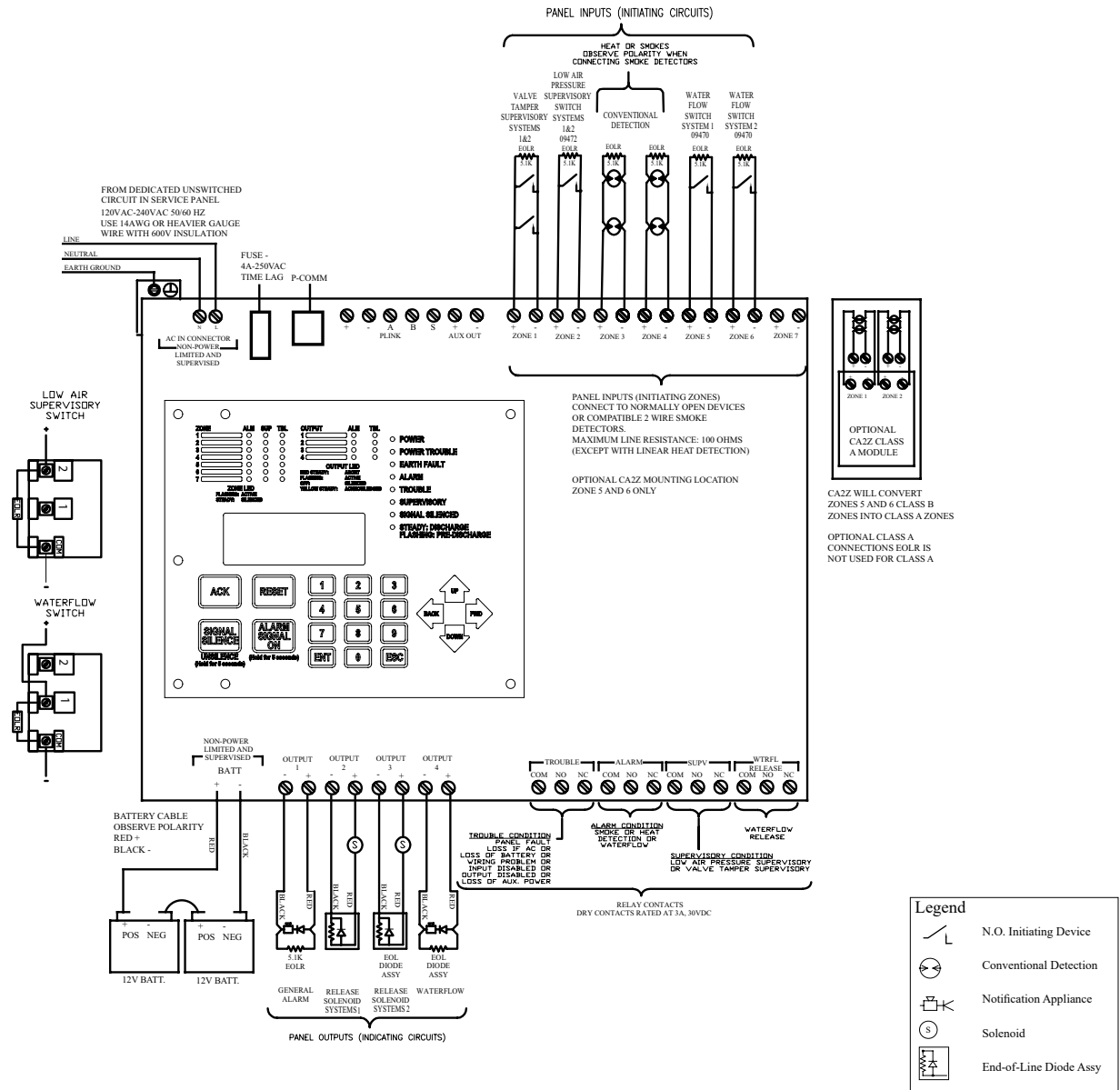

**NOTES:**

1. Run field wiring and ensure connections are proper by metering wires. Resistance reading should be 5.1K ohms with end-offline resistor (EOLR) at last device. The end-of-line resistor are supplied with the panel. Install EOLR on all unused circuits.
2. Connect one circuit at a time and apply AC power.
3. Connect batteries to the panel
4. Press ENT to enter PROGRAM mode
5. Press 6 or scroll down to #6 and press ENT, (The selection is indicated by a flashing arrow next to the number.
6. Enter the password. (Factory default is 1111)
7. Press 1 or press ENT. (1 should be the highlighted selection)
8. The display shows the current program number. Press 2 to change to program 2. Press ENT.
9. Press 1 to accept the change.
10. Press ENT to accept the change



| PROGRAM #2  |  |  |  |  |                             |                             |        |
|---|--|--|--|--|-----------------------------|-----------------------------|--------|
| For Two Sprinkler Systems Operating Independantly From Each Other |  |  |  |  |                             |                             |        |
| Viking Sprinkler System Types                                     | 2 Split Release Zones and 2 Waterflow Zones  | 1. Single Interlocked Preaction System with Electric Release           |  |  |                             |                             |        |
|   |  | 2. Deluge System with Electric Release                                 |  |  |                             |                             |        |
|   |  | 3. Non-Interlocked Preaction System with Electric Release              |  |  |                             |                             |        |
|   |  | 4. Double Interlocked Preaction System with Electric/Pneumatic Release |  |  |                             |                             |        |
| OUTPUTS<br>(Indicating Circuits)                                  | ZONES (Initiating Circuits)  |  |  |  |                             |                             |        |
|   | #1   | #2   | #3                                       | #4                                       | #5                          | #6                          | #7     |
|   | Valve Tamper Supervisory Zone for Systems 1 & 2  | Low Air Supervisory Zone for Systems 1 & 2                             | Conventional Detection Zone for System 1 | Conventional Detection Zone for System 2 | Waterflow Zone for System 1 | Waterflow Zone for System 2 | Unused |
|   | #1 General Alarm   |  | X  | X  | X                           | X                           |        |
|   | #2 Release Solenoid #1   |  | X  |  |                             |                             |        |
| #3 Release Solenoid #2  |  |  |  | X  |                             |                             |        |
| #4 Waterflow  |  |  |  |  | X                           | X                           |        |
| OPERATION DESCRIPTION   |  |  |  |  |                             |                             |        |
| Inputs:   | 2 Conventional Detection zones, 2 Waterflow zones, 2 Supervisory zones   |  |  |  |                             |                             |        |
| Outputs:  | 1 General Alarm, 1 Waterflow Alarm, 2 Solenoid Release   |  |  |  |                             |                             |        |
| Operation:  | Activation of Conventional Detection zone #3 will activate output #2 (Release Solenoid #1) and output #1 (General Alarm) |  |  |  |                             |                             |        |
|   | Activation of Conventional Detection zone #4 will activate output #3 (Release Solenoid #2) and output #1 (General Alarm) |  |  |  |                             |                             |        |
|   | Activation of Waterflow zone #5 or #6 will activate output #1 (General Alarm) and output #4 (Waterflow)                  |  |  |  |                             |                             |        |
|   | Activation of Valve Tamper Supervisory zone #1 or Low Air Supervisory zone #2 will operate supervisory trouble relay.    |  |  |  |                             |                             |        |

**NOTES:**

1. Connect EOL Diode assembly IN SERIES as shown with Solenoid on output #2 (Release Solenoid) and output #3 (Release Solenoid). Black wire to negative terminal on panel and Red wire through Solenoid to positive terminal on panel.
2. Polarity is shown on indicating circuits in an activated (in alarm) condition.
3. Install EOLR (provided) on all unused circuits.
4. See the instruction manual for circuit information, panel limits, and battery sizing.
5. For wire routing instructions through the releasing panel, see Fig 1 on page 2-7 of the instruction manual.
6. See instruction manual for proper programming.
7. See instruction manual for list of compatible smoke detectors.
8. See specific system type data page for proper pressure switch settings.

PROGRAM #3

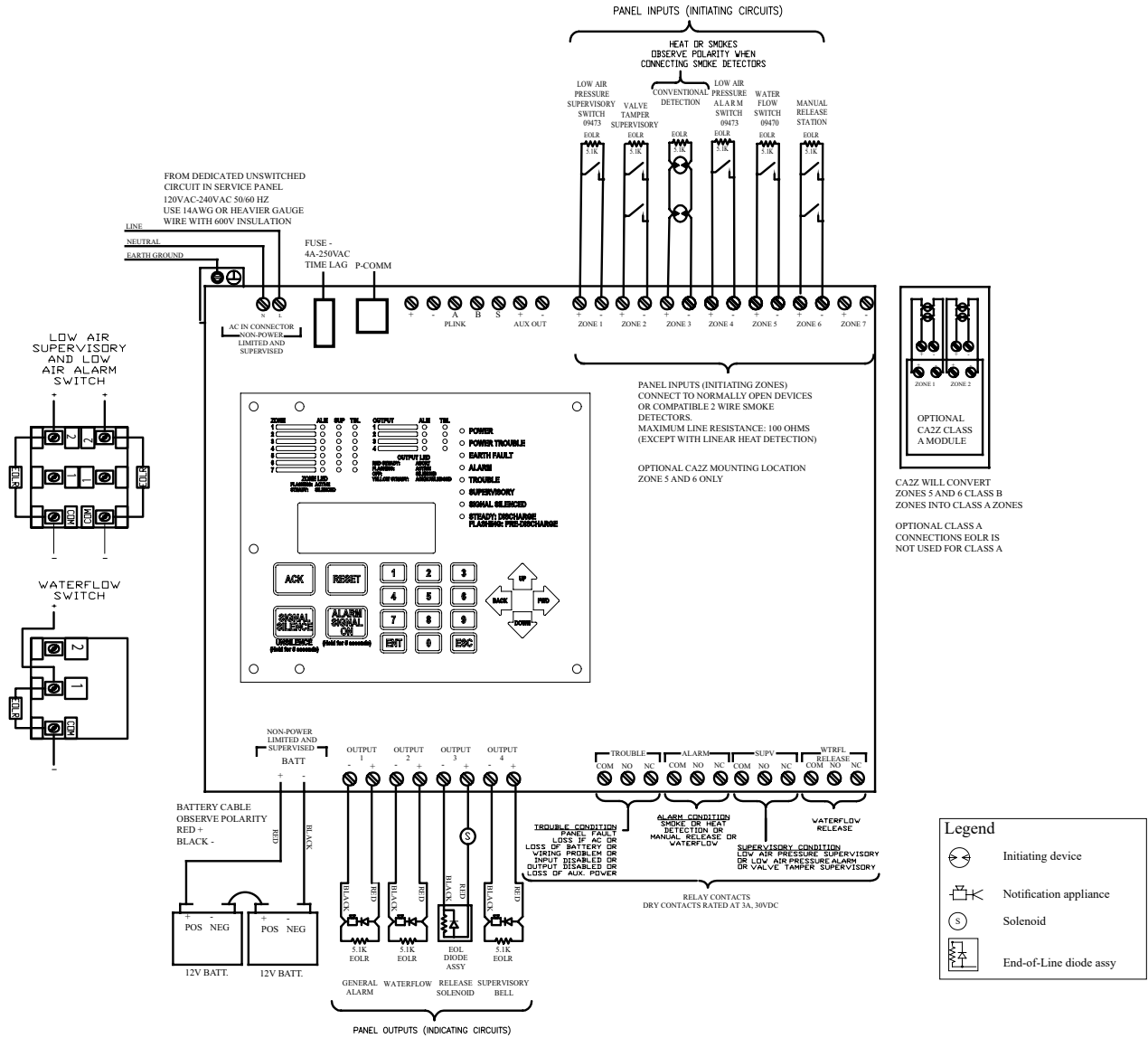

NOTES:

1. Run field wiring and ensure connections are proper by metering wires. Resistance reading should be 5.1K ohms with end-offline resistor (EOLR) at last device. The end-of-line resistor are supplied with the panel. Install EOLR on all unused circuits.
2. Connect one circuit at a time and apply AC power.
3. Connect batteries to the panel
4. Press ENT to enter PROGRAM mode
5. Press 6 or scroll down to #6 and press ENT, (The selection is indicated by a flashing arrow next to the number.)
6. Enter the password. (Factory default is 1111)
7. Press 1 or press ENT. (1 should be the highlighted selection)
8. The display shows the current program number. Press 3 to change to program 3. Press ENT.
9. Press 1 to accept the change.
10. Press ENT to accept the change

| PROGRAM #3  |  |   |                             |                    |                |                     |        |                   |  |
|---|--|---|-----------------------------|--------------------|----------------|---------------------|--------|-------------------|--|
| For One Sprinkler System  |  |   |                             |                    |                |                     |        |                   |  |
| Viking Sprinkler System Types   | 2 Cross Release zones, Waterflow zone, and Manual Release zone   | 1. Double Interlocked Preaction System with Electric/Pneu-Lectric Release |                             |                    |                |                     |        |                   |  |
| OUTPUTS<br>(Indicating Circuits)  | ZONES (Initiating Circuits)  |   |                             |                    |                |                     |        | Software Zone     |  |
|   | #1   | #2  | #3                          | #4                 | #5             | #6                  | #7     | #8                |  |
|   | Low Air Supervisory Zone   | Valve Tamper Supervisory Zone   | Conventional Detection Zone | Low Air Alarm Zone | Waterflow Zone | Manual Release Zone | Unused | Release Type Zone |  |
| #1 General Alarm  |  |   | X                           |                    | X              | X                   |        | X                 |  |
| #2 Waterflow  |  |   |                             |                    | X              |                     |        |                   |  |
| #3 Release Solenoid   |  |   | XX                          | XX                 |                | X                   |        | XX*               |  |
| #4 Supervisory Bell   | X  | X   |                             | X                  |                |                     |        |                   |  |
| OPERATION DESCRIPTION   |  |   |                             |                    |                |                     |        |                   |  |
| Inputs:   | 1 Conventional Detection zone cross zoned with 1 Low Air Alarm zone, 1 Waterflow zone, 1 Manual Release zone, 2 Supervisory zones  |   |                             |                    |                |                     |        |                   |  |
| Outputs:  | 1 General Alarm, 1 Waterflow, 1 Release Solenoid, 1 Supervisory Bell   |   |                             |                    |                |                     |        |                   |  |
| Operation:  | Simultaneous activation of both the Conventional Detection zone #3 and the Low Air Alarm zone #4 will activate output #3 (Release solenoid), output #1 (General alarm), and output #4 (Supervisory Bell) |   |                             |                    |                |                     |        |                   |  |
|   | Activation of Conventional Detection zone #3 will activate output #1 (General Alarm)   |   |                             |                    |                |                     |        |                   |  |
|   | Activation of Low Air Alarm zone #4 will activate output #4 (Supervisory Bell)   |   |                             |                    |                |                     |        |                   |  |
|   | Activation of Waterflow zone #5 will activate output #2 (Waterflow) and output #1 (General Alarm)  |   |                             |                    |                |                     |        |                   |  |
|   | Activation of Manual Release zone #6 will activate output #3 (Release Solenoid) and output #1 (General Alarm)  |   |                             |                    |                |                     |        |                   |  |
| Activation of Low Air Supervisory zone #1 or Valve Tamper Supervisory zone #2 will operate output #4 (Supervisory Bell) |  |   |                             |                    |                |                     |        |                   |  |

\* Release Outputs which are Cross-Zoned need a Software Zone in order to work properly. The Software Zone Number will be displayed upon a release.

XX = Cross-Zoned

**NOTES:**

1. Connect EOL Diode assembly IN SERIES as shown with Solenoid on output #3 (Release Solenoid). Black wire to negative terminal on panel and Red wire through Solenoid to positive terminal on panel.
2. Polarity is shown on indicating circuits in an activated (in alarm) condition.
3. Install EOLR (provided) on all unused circuits.
4. See the instruction manual for circuit information, panel limits, and battery sizing.
5. For wire routing instructions through the releasing panel, see Fig 1 on page 2-7 of the instruction manual.
6. See instruction manual for proper programming.
7. See instruction manual for list of compatible smoke detectors.
8. See specific system type data page for proper pressure switch settings.

**PROGRAM #4**

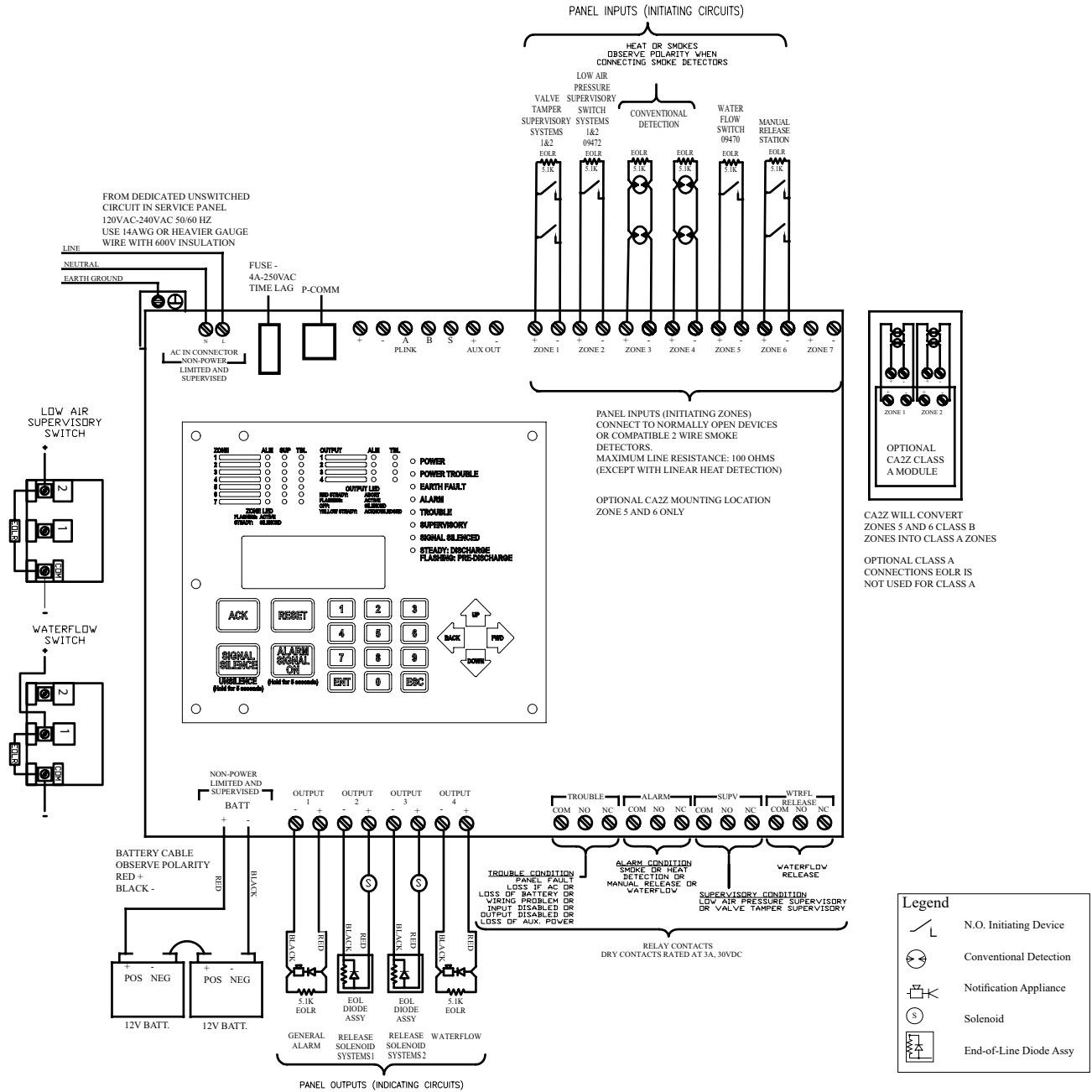

**NOTES:**

1. Run field wiring and ensure connections are proper by metering wires. Resistance reading should be 5.1K ohms with end-offline resistor (EOLR) at last device. The end-of-line resistor are supplied with the panel Install EOLR on all unused circuits.
2. Connect one circuit at a time and apply AC power.
3. Connect batteries to the panel
4. Press ENT to enter PROGRAM mode
5. Press 6 or scroll down to #6 and press ENT, (The selection is indicated by a flashing arrow next to the number.
6. Enter the password. (Factory default is 1111)
7. Press 1 or press ENT. (1 should be the highlighted selection)
8. The display shows the current program number. Press 4 to change to program 4. Press ENT.
9. Press 1 to accept the change.
10. Press ENT to accept the change

| PROGRAM #4   |  |  |  |  |                |                     |        |
|--|--|--|--|--|----------------|---------------------|--------|
| For Two Sprinkler Systems - Operating Simultaneously |  |  |  |  |                |                     |        |
| Viking Sprinkler System Types                        | 2 Dual Release Zones, Waterflow Zone, and Dual Manual Release Zone   | 1. Single Interlocked Preaction System with Electric Release           |  |  |                |                     |        |
|  |  | 2. Deluge System with Electric Release                                 |  |  |                |                     |        |
|  |  | 3. Non-Interlocked Preaction System with Electric Release              |  |  |                |                     |        |
|  |  | 4. Double Interlocked Preaction System with Electric/Pneumatic Release |  |  |                |                     |        |
| OUTPUTS (Indicating Circuits)                        | ZONES (Initiating Circuits)  |  |  |  |                |                     |        |
|  | #1   | #2   | #3                                       | #4                                       | #5             | #6                  | #7     |
|  | Valve Tamper Supervisory Zone for Systems 1 & 2  | Low Air Supervisory Zone for Systems 1 & 2                             | Conventional Detection Zone for System 1 | Conventional Detection Zone for System 2 | Waterflow Zone | Manual Release Zone | Unused |
| #1 General Alarm                                     |  |  | X  | X  | X              | X                   |        |
| #2 Release Solenoid #1                               |  |  | X  | X  |                | X                   |        |
| #3 Release Solenoid #2                               |  |  | X  | X  |                | X                   |        |
| #4 Waterflow   |  |  |  |  | X              |                     |        |
| OPERATION DESCRIPTION                                |  |  |  |  |                |                     |        |
| Inputs:  | 2 Conventional Detection zones, 1 Waterflow zone, 1 Manual Release zone, 2 Supervisory zones   |  |  |  |                |                     |        |
| Outputs:   | 1 General Alarm, 1 Waterflow, 2 Release Solenoids  |  |  |  |                |                     |        |
| Operation:   | Activation of Conventional Detection zone #3 or #4 or Manual Release zone #6 will activate output #2 (Release Solenoid #1) and output #3 (Release Solenoid #2) and output #1 (General Alarm) |  |  |  |                |                     |        |
|  | Activation of Waterflow zone #5 will activate output #4 (Waterflow) and output #1 (General Alarm)  |  |  |  |                |                     |        |
|  | Activation of Valve Tamper Supervisory zone #1 or Low Air Supervisory zone #2 will operate supervisory trouble relay   |  |  |  |                |                     |        |

**NOTES:**

1. Connect EOL Diode assembly IN SERIES as shown with Solenoid on output #2 (Release Solenoid) and output #3 (Release Solenoid). Black wire to negative terminal on panel and Red wire through Solenoid to positive terminal on panel.
2. Polarity is shown on indicating circuits in an activated (in alarm) condition.
3. Install EOLR (provided) on all unused circuits.
4. See the instruction manual for circuit information, panel limits, and battery sizing.
5. For wire routing instructions through the releasing panel, see Fig 1 on page 2-7 of the instruction manual.
6. See instruction manual for proper programming.
7. See instruction manual for list of compatible smoke detectors.
8. See specific system type data page for proper pressure switch settings.

PROGRAM #5

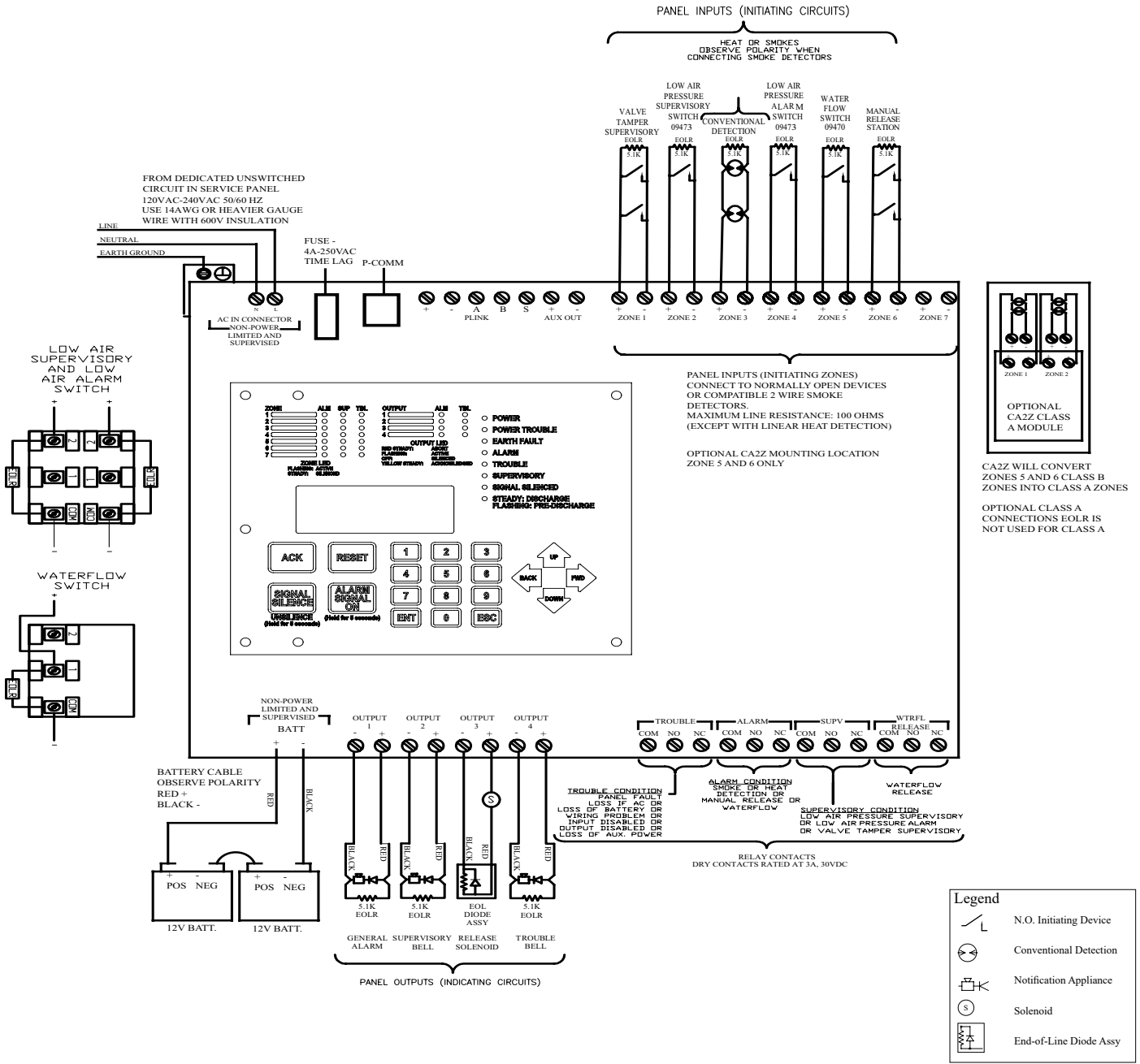

NOTES:

1. Run field wiring and ensure connections are proper by metering wires. Resistance reading should be 5.1K ohms with end-offline resistor (EOLR) at last device. The end-of-line resistor are supplied with the panel Install EOLR on all unused circuits.
2. Connect one circuit at a time and apply AC power.
3. Connect batteries to the panel
4. Press ENT to enter PROGRAM mode
5. Press 6 or scroll down to #6 and press ENT, (The selection is indicated by a flashing arrow next to the number.
6. Enter the password. (Factory default is 1111)
7. Press 1 or press ENT. (1 should be the highlighted selection)
8. The display shows the current program number. Press 5 to change to program 5. Press ENT.
9. Press 1 to accept the change.
10. Press ENT to accept the change

| PROGRAM #5                            |   |  |                             |                    |                |                     |        |
|---------------------------------------|---|--|-----------------------------|--------------------|----------------|---------------------|--------|
| For One Sprinkler System- NYC Special |   |  |                             |                    |                |                     |        |
| Viking Sprinkler System Types         | Release Zone and Manual Release Zone  | 1. Single Interlocked Preaction System with Electric Release           |                             |                    |                |                     |        |
|                                       |   | 2. Deluge System with Electric Release                                 |                             |                    |                |                     |        |
|                                       |   | 3. Non-Interlocked Preaction with Electric Release                     |                             |                    |                |                     |        |
|                                       |   | 4. Double Interlocked Preaction System with Electric/Pneumatic Release |                             |                    |                |                     |        |
| OUTPUTS<br>(Indicating Circuits)      | ZONES (Initiating Circuits)   |  |                             |                    |                |                     |        |
|                                       | #1  | #2   | #3                          | #4                 | #5             | #6                  | #7     |
|                                       | Valve Tamper Supervisory Zone   | Low Air Supervisory Zone   | Conventional Detection Zone | Low Air Alarm Zone | Waterflow Zone | Manual Release Zone | Unused |
| #1 General Alarm                      |   |  | X                           |                    | X              | X                   |        |
| #2 Supervisory Bell                   | X   | X  |                             | X                  |                |                     |        |
| #3 Release Solenoid                   |   |  | X                           |                    |                | X                   |        |
| #4 Trouble Bell                       |   |  |                             |                    |                |                     |        |
| OPERATION DESCRIPTION                 |   |  |                             |                    |                |                     |        |
| Inputs:                               | 1 Conventional Detection zone, 1 Waterflow zone, 1 Low Air Alarm zone, 1 Manual Release zone, 2 Supervisory zones                               |  |                             |                    |                |                     |        |
| Outputs:                              | 1 General Alarm, 1 Trouble Bell, 1 Release Solenoid, 1 Supervisory Bell   |  |                             |                    |                |                     |        |
| Operation:                            | Activation of Conventional Detection zone #4 or Manual Release zone #6 will activate output #3 (Release Solenoid) and output #1 (General Alarm) |  |                             |                    |                |                     |        |
|                                       | Activation of Waterflow zone #5 will activate output #1 (General Alarm)   |  |                             |                    |                |                     |        |
|                                       | Activation of Low Air Alarm zone #2 or Low Air Supervisory zone or Valve Tamper Supervisory zone #1 will activate output #2 (Supervisory Bell)  |  |                             |                    |                |                     |        |
|                                       | A trouble condition, (low battery, wire short in outputs, loss AC, panel problem) will activate output #4 (Trouble Bell) and trouble relay      |  |                             |                    |                |                     |        |

**NOTES:**

1. Connect EOL Diode assembly IN SERIES as shown with Solenoid on output #2 (Release Solenoid) and output #3 (Release Solenoid). Black wire to negative terminal on panel and Red wire through Solenoid to positive terminal on panel.
2. Polarity is shown on indicating circuits in an activated (in alarm) condition.
3. Install EOLR (provided) on all unused circuits.
4. See the instruction manual for circuit information, panel limits, and battery sizing.
5. For wire routing instructions through the releasing panel, see Fig 1 on page 2-7 of the instruction manual.
6. See instruction manual for proper programming.
7. See instruction manual for list of compatible smoke detectors.
8. See specific system type data page for proper pressure switch settings.

**PROGRAM #6**

| WATER SUPPLY (psig) | RECOMMENDED AIR PRESSURE SETTINGS |  |
|---------------------|-----------------------------------|--|
|                     | LOW AIR ALARM ZONE #2 (psig)      | LOW AIR SUPERVISORY SUP ZONE #1 (psig) |
| 0 - 175             | 30                                | 30                                     |
| 175 - 250           | 50                                | 50                                     |

| EXTRA HAZARD APPLICATIONS   |          |                          |          | ORDINARY & LIGHT HAZARD APP.   |          |                 |          |
|-----------------------------|----------|--------------------------|----------|--------------------------------|----------|-----------------|----------|
| FIRECYCLE DETECTORS MODEL B |          |                          |          | FIRECYCLE OH DETECTORS MODEL C |          |                 |          |
| WITH 04632A CABLE           |          | WITH FPL WIRE IN CONDUIT |          | FLUSH MOUNTED                  |          | SURFACE MOUNTED |          |
| TEMP. F°                    | PART NO. | TEMP. F°                 | PART NO. | TEMP. F°                       | PART NO. | TEMP. F°        | PART NO. |
| 140                         | 04711A   | 140                      | 08288    | 140                            | 11723    | 140             | 11727    |
| 160                         | 04717A   | 160                      | 08289    | 160                            | 11724    | 160             | 11728    |
| 190                         | 04718A   | 190                      | 08290    | 190                            | 11725    | 190             | 11729    |
| 225                         | 04719A   | 225                      | 08291    | 225                            | 11726    | 225             | 11730    |

**PANEL INPUTS (INITIATING CIRCUITS)**

**EOLR REQUIRED AFTER LAST DETECTOR FOR SUPERVISION**

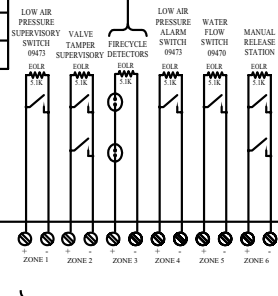

PANEL INPUTS (INITIATING ZONES) CONNECT TO NORMALLY OPEN DEVICES OR COMPATIBLE 2 WIRE SMOKE DETECTORS. MAXIMUM LINE RESISTANCE: 100 OHMS (EXCEPT WITH LINEAR HEAT DETECTION).  
OPTIONAL CAZZ MOUNTING LOCATION ZONE 5 AND 6 ONLY

RELAY CONTACTS DRY CONTACTS RATED AT 3A, 30VDC

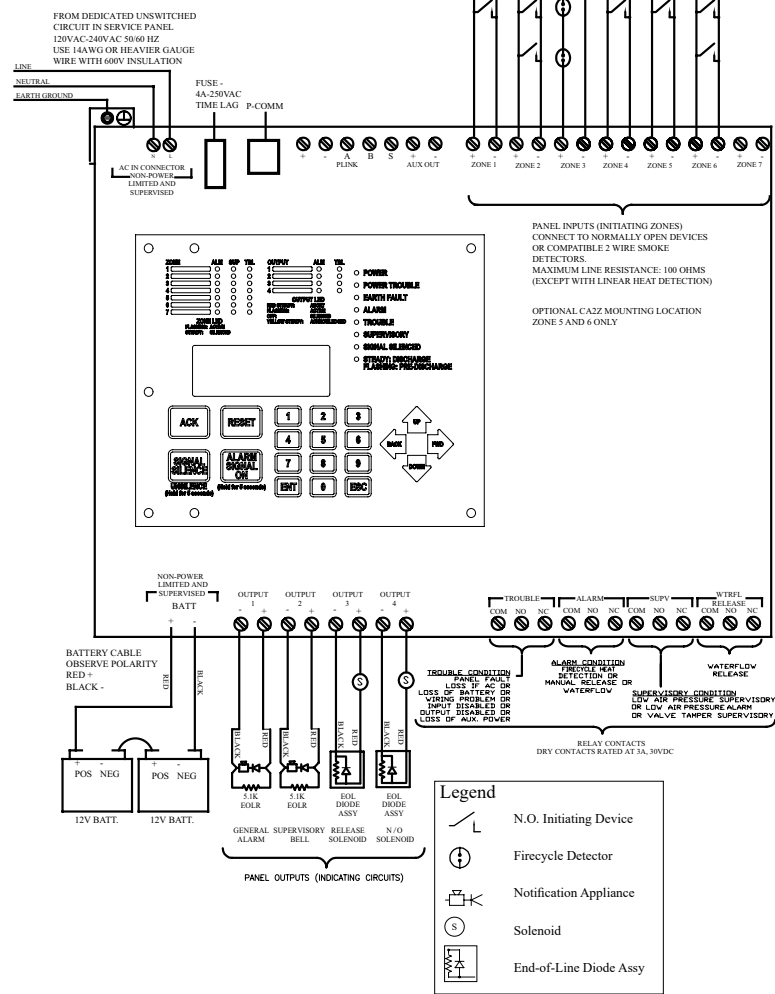
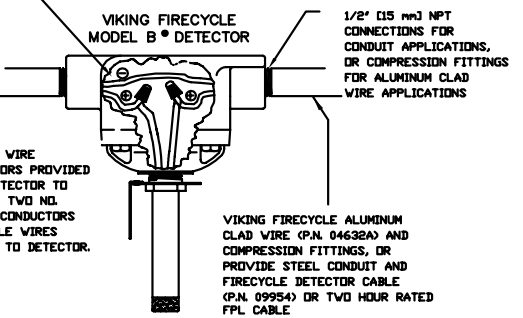
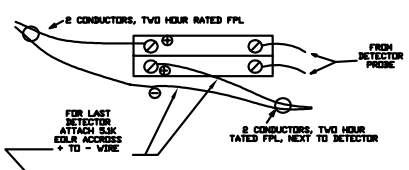
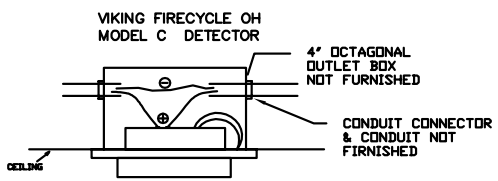
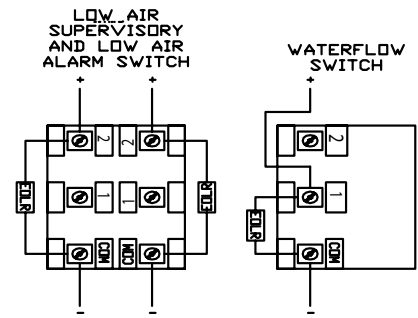

**NOTES:**

1. Run field wiring and ensure connections are proper by metering wires. Resistance reading should be 5.1K ohms with end-offline resistor (EOLR) at last device. The end-of-line resistor are supplied with the panel Install EOLR on all unused circuits.
2. Connect one circuit at a time and apply AC power.
3. Connect batteries to the panel
4. Press ENT to enter PROGRAM mode
5. Press 6 or scroll down to #6 and press ENT, (The selection is indicated by a flashing arrow next to the number.)
6. Enter the password. (Factory default is 1111)
7. Press 1 or press ENT. (1 should be the highlighted selection)
8. The display shows the current program number. Press 6 to change to program 6. Press ENT.
9. Press 1 to accept the change.
10. Press ENT to accept the changer



| PROGRAM #6                       |  |   |                         |                    |                |                     |        |
|----------------------------------|--|---|-------------------------|--------------------|----------------|---------------------|--------|
| For One Sprinkler System         |  |   |                         |                    |                |                     |        |
| Viking Sprinkler System Types    | Release Zone and Manual Release Zone   | 1. FIRECYCLE III Single Interlocked Preaction Multicycle System               |                         |                    |                |                     |        |
|                                  |  | 2. FIRECYCLE III Single Interlocked Preaction Multicycle System - NYC Special |                         |                    |                |                     |        |
| OUTPUTS<br>(Indicating Circuits) | ZONES (Initiating Circuits)  |   |                         |                    |                |                     |        |
|                                  | #1   | #2  | #3                      | #                  | #5             | #6                  | #7     |
|                                  | Low Air Supervisory Zone   | Valve Tamper Supervisory Zone   | FIRECYCLE Detector Zone | Low Air Alarm Zone | Waterflow Zone | Manual Release Zone | Unused |
| #1 General Alarm                 |  |   | X                       |                    | X              | X                   |        |
| #2 Supervisory Bell              | X  | X   |                         | X                  |                |                     |        |
| #3 Release Solenoid              |  |   | X                       |                    |                | X                   |        |
| #4 N/O Solenoid                  |  |   | X                       | X                  | X              |                     |        |
| OPERATION DESCRIPTION            |  |   |                         |                    |                |                     |        |
| Inputs:                          | FIRECYCLE Detector zone, Low Air Alarm zone, 1 Waterflow zone, 1 Manual Release zone, 2 Supervisory zones                                    |   |                         |                    |                |                     |        |
| Outputs:                         | 1 General Alarm, 1 Supervisory Alarm, 1 Release Solenoid, and 1 N/O Solenoid   |   |                         |                    |                |                     |        |
| Operation:                       | Activation of FIRECYCLE Detector zone #3 will activate output #1 (General Alarm), output #3 (Release Solenoid), and output #4 (N/O Solenoid) |   |                         |                    |                |                     |        |
|                                  | Activation of Low Air Alarm zone #4 will activate output #2 (Supervisory Bell) and output #4 (N/O Solenoid)                                  |   |                         |                    |                |                     |        |
|                                  | Activation of Waterflow zone #5 will activate output #1 (General Alarm) and output #4 (N/O Solenoid)   |   |                         |                    |                |                     |        |
|                                  | Activation of Manual Release zone #6 will activate output #1 (General Alarm) and output #3 (Release Solenoid)                                |   |                         |                    |                |                     |        |
|                                  | Deactivation of FIRECYCLE Detector zone #3 will start soak timer, when timer cycle is complete output #3 (Release Solenoid) is deactivated   |   |                         |                    |                |                     |        |
|                                  | Activation of Low Air Supervisory Zone #1 or Valve Tamper Supervisory zone #2 will activate output #2 (Supervisory Bell)                     |   |                         |                    |                |                     |        |

**NOTES:**

1. Connect EOL Diode assembly IN SERIES as shown with Solenoid on output #3 (Release Solenoid) and output #4 (N/O Solenoid). Black wire to negative terminal on panel and Red wire through Solenoid to positive terminal on panel.
2. Polarity is shown on indicating circuits in an activated (in alarm) condition.
3. Install EOLR (provided) on all unused circuits.
4. See the instruction manual for circuit information, panel limits, and battery sizing.
5. For wire routing instructions through the releasing panel, see Fig 1 on page 2-7 of the instruction manual.
6. See instruction manual for proper programming.
7. See specific system type data page for proper pressure switch settings.
8. Connect EOL resistor after last FIRECYCLE detector on return line to common terminal in FIRECYCLE Detector zone #1.
9. Set the soak timer to desired duration period. Factory setting is continuous. Recommend 60 seconds minimum.
10. Loss of DC power below 20 volt causes output #3 (Release Solenoid) and output #4 (N/O Solenoid) to drop out.
11. Use only Viking FIRECYCLE detectors on FIRECYCLE Detector zone #1.
12. Refer to Viking technical data sheet F\_051304 for Firecycle single interlock multi-cycle operation.
13. For UL864 Approved Programming Options, see page 6-102.

PROGRAM #7

| RECOMMENDED AIR PRESSURE SETTINGS |                              |  |
|-----------------------------------|------------------------------|--|
| WATER SUPPLY (psig)               | LOW AIR ALARM ZONE #2 (psig) | LOW AIR SUPERVISORY SUP ZONE #1 (psig) |
| 0 - 175                           | 30                           | 30                                     |
| 175 - 250                         | 50                           | 50                                     |

| EXTRA HAZARD APPLICATIONS   |          |                          |          | ORDINARY & LIGHT HAZARD APP.   |          |                 |          |
|-----------------------------|----------|--------------------------|----------|--------------------------------|----------|-----------------|----------|
| FIRECYCLE DETECTORS MODEL B |          |                          |          | FIRECYCLE OH DETECTORS MODEL C |          |                 |          |
| WITH 04632A CABLE           |          | WITH FPL WIRE IN CONDUIT |          | FLUSH MOUNTED                  |          | SURFACE MOUNTED |          |
| TEMP. F°                    | PART NO. | TEMP. F°                 | PART NO. | TEMP. F°                       | PART NO. | TEMP. F°        | PART NO. |
| 140                         | 04711A   | 140                      | 08288    | 140                            | 11723    | 140             | 11727    |
| 160                         | 04717A   | 160                      | 08289    | 160                            | 11724    | 160             | 11728    |
| 190                         | 04718A   | 190                      | 08290    | 190                            | 11725    | 190             | 11729    |
| 225                         | 04719A   | 225                      | 08291    | 225                            | 11726    | 225             | 11730    |

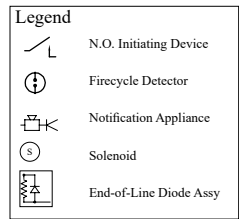
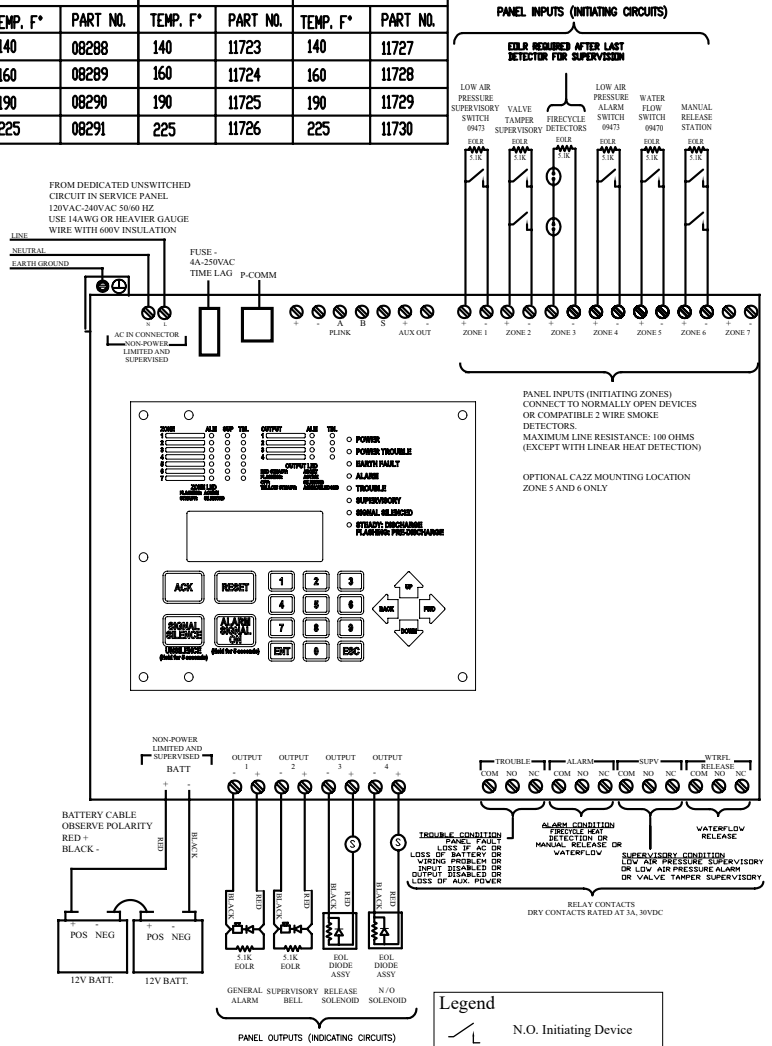
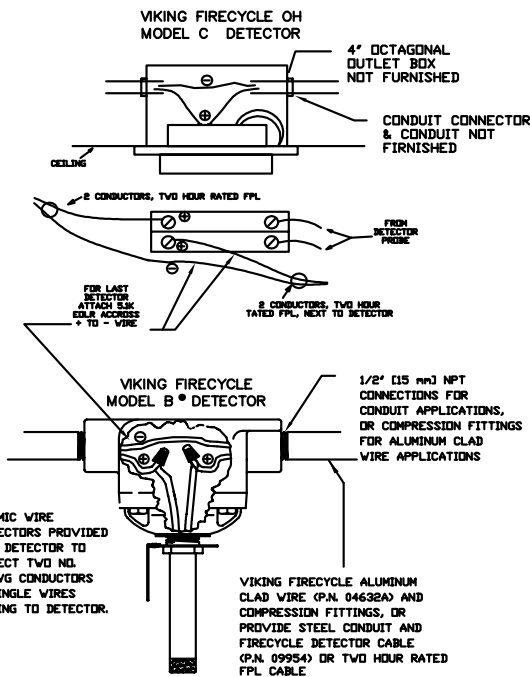
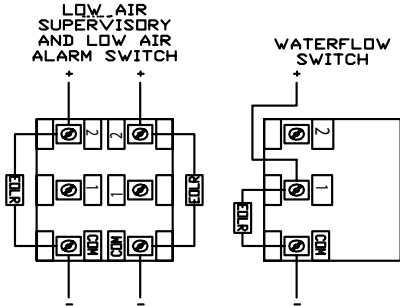

NOTES:

1. Run field wiring and ensure connections are proper by metering wires. Resistance reading should be 5.1K ohms with end-offline resistor (EOLR) at last device. The end-of-line resistor are supplied with the panel Install EOLR on all unused circuits.
2. Connect one circuit at a time and apply AC power.
3. Connect batteries to the panel
4. Press ENT to enter PROGRAM mode
5. Press 6 or scroll down to #6 and press ENT, (The selection is indicated by a flashing arrow next to the number.
6. Enter the password. (Factory default is 1111)
7. Press 1 or press ENT. (1 should be the highlighted selection)
8. The display shows the current program number. Press 7 to change to program 7. Press ENT.
9. Press 1 to accept the change.
10. Press ENT to accept the change

| PROGRAM #7   |   |   |                          |                    |                |                     |        |                   |
|--|---|---|--------------------------|--------------------|----------------|---------------------|--------|-------------------|
| For One Sprinkler System   |   |   |                          |                    |                |                     |        |                   |
| Viking Sprinkler System Types  | Release Zone and Manual Release Zone  | 1. FIRECYCLE III Double Interlocked Preaction Multicycle System               |                          |                    |                |                     |        |                   |
|  |   | 2. FIRECYCLE III Double Interlocked Preaction Multicycle System - NYC Special |                          |                    |                |                     |        |                   |
| OUTPUTS<br>(Indicating Circuits)   | ZONES (Initiating Circuits)   |   |                          |                    |                |                     |        | Software Zone     |
|  | #1  | #2  | #3                       | #4                 | #5             | #6                  | #7     | #8                |
|  | Low Air Supervisory Zone  | Valve Tamper Supervisory Zone   | FIRECYCLE Detection Zone | Low Air Alarm Zone | Waterflow Zone | Manual Release Zone | Unused | Release Type Zone |
| #1 General Alarm   |   |   | X                        |                    | X              | X                   |        | X                 |
| #2 Supervisory Bell  | X   | X   |                          | X                  |                |                     |        |                   |
| #3 Release Solenoid  |   |   | X X                      | X X                |                | X                   |        | XX*               |
| #4 N/O Solenoid  |   |   |                          | X                  | X              |                     |        |                   |
| OPERATION DESCRIPTION  |   |   |                          |                    |                |                     |        |                   |
| Inputs:  | 1 FIRECYCLE Detector zone, 1 Low Air Alarm zone, 1 Waterflow zone, 1 Manual Release zone, 2 Supervisory zones   |   |                          |                    |                |                     |        |                   |
| Outputs:   | 1 General Alarm, 1 Supervisory Bell, 1 Release Solenoid, and 1 N/O Solenoid   |   |                          |                    |                |                     |        |                   |
| Operation:   | Simultaneous activation of both the FIRECYCLE Detector zone #3 and the Low Air alarm zone #4 will activate output #1 (General Alarm), output #2 (Supervisory Bell), output #3 (Release Solenoid), and output #4 (N/O Solenoid). |   |                          |                    |                |                     |        |                   |
|  | Activation of FIRECYCLE Detector zone #3 will activate output #1 (General Alarm)  |   |                          |                    |                |                     |        |                   |
|  | Activation of Low Air Alarm zone #4 alone will activate output #2 (Supervisory Bell) and output #4 (N/O Solenoid)   |   |                          |                    |                |                     |        |                   |
|  | Activation of Waterflow zone #5 will activate output #1 (General Alarm) and output #4 (N/O solenoid)  |   |                          |                    |                |                     |        |                   |
|  | Activation of Manual Release zone #6 will activate output #1 (General Alarm) and output #3 (Release Solenoid)   |   |                          |                    |                |                     |        |                   |
|  | Deactivation of FIRECYCLE Detector zone #3 will start soak timer, when timer cycle is complete the output #3 (Release Solenoid) is deactivated.   |   |                          |                    |                |                     |        |                   |
| Activation of Low Air Supervisory zone #1 or Valve Tamper Supervisory zone #2 will activate output #2 (Supervisory Bell) |   |   |                          |                    |                |                     |        |                   |

\* Release Outputs which are Cross-Zoned need a Software Zone in order to work properly. The Software Zone Number will be displayed upon a release.

XX = Cross-Zoned

**NOTES:**

1. Connect EOL Diode assembly IN SERIES as shown with Solenoid on output #3 (Release Solenoid) and output #4 (N/O Solenoid). Black wire to negative terminal on panel and Red wire through Solenoid to positive terminal on panel.
2. Polarity is shown on indicating circuits in an activated (in alarm) condition.
3. Install EOLR (provided) on all unused circuits.
4. See the instruction manual for circuit information, panel limits, and battery sizing.
5. For wire routing instructions through the releasing panel, see Fig 1 on page 2-7 of the instruction manual.
6. See instruction manual for proper programming.
7. See specific system type data page for proper pressure switch settings.
8. Connect EOL resistor after last FIRECYCLE detector on return line to common terminal in FIRECYCLE Detector zone #1.
9. Set the soak timer to desired duration period. Factory setting is continuous. Recommend 60 seconds minimum.
10. Loss of DC power below 20 volt causes output #3 (Release Solenoid) to drop out.
11. Use only Viking FIRECYCLE detectors on FIRECYCLE Detector zone #1.
12. Refer to Viking technical data sheet F\_051304 for Firecycle double interlock multi-cycle operation.
13. For UL864 Approved Programming Options, see page 6-102.

PROGRAM #8

| EXTRA HAZARD APPLICATIONS   |          |          |          | ORDINARY & LIGHT HAZARD APP.   |          |          |          |
|-----------------------------|----------|----------|----------|--------------------------------|----------|----------|----------|
| FIRECYCLE DETECTORS MODEL B |          |          |          | FIRECYCLE OH DETECTORS MODEL C |          |          |          |
| WITH 04632A CABLE           |          |          |          | WITH FPL WIRE IN CONDUIT       |          |          |          |
| TEMP. F°                    | PART NO. | TEMP. F° | PART NO. | TEMP. F°                       | PART NO. | TEMP. F° | PART NO. |
| 140                         | 0471A    | 140      | 08288    | 140                            | 11723    | 140      | 11727    |
| 160                         | 0471A    | 160      | 08289    | 160                            | 11724    | 160      | 11728    |
| 190                         | 0471A    | 190      | 08290    | 190                            | 11725    | 190      | 11729    |
| 225                         | 0471A    | 225      | 08291    | 225                            | 11726    | 225      | 11730    |

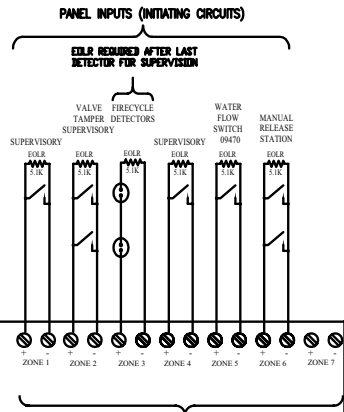

FROM DEDICATED UNSWITCHED CIRCUIT IN SERVICE PANEL  
120VAC-240V AC 50/60 HZ  
USE 14AWG OR HEAVIER GAUGE WIRE WITH 600V INSULATION

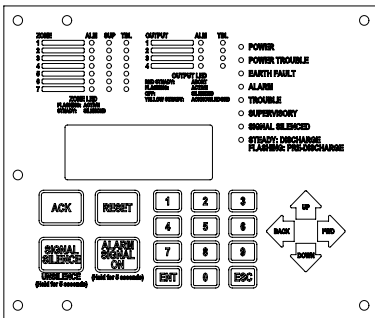
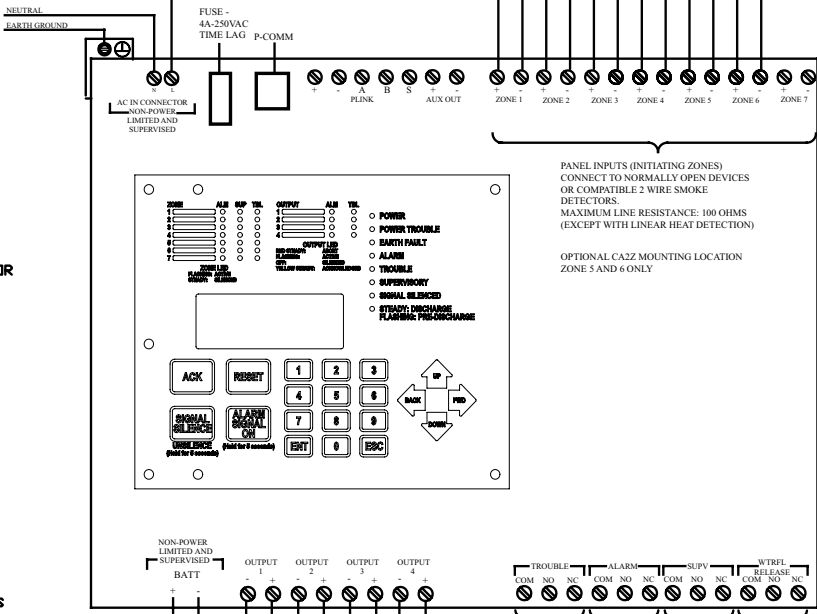

PANEL INPUTS (INITIATING ZONES)  
CONNECT TO NORMALLY OPEN DEVICES OR COMPATIBLE 2 WIRE SMOKE DETECTORS.  
MAXIMUM LINE RESISTANCE: 100 OHMS (EXCEPT WITH LINEAR HEAT DETECTORS)  
OPTIONAL CAZZ MOUNTING LOCATION ZONE 5 AND 6 ONLY

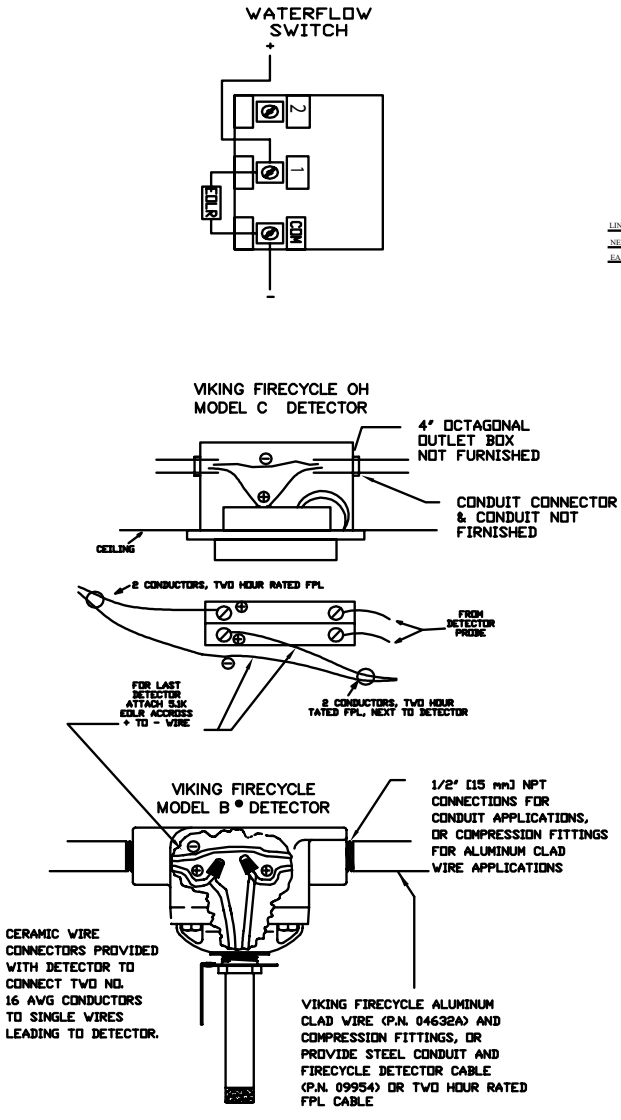
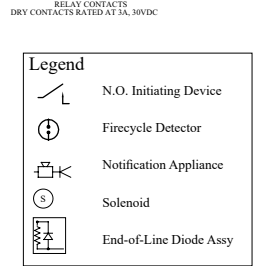

NOTES:

1. Run field wiring and ensure connections are proper by metering wires. Resistance reading should be 5.1K ohms with end-of-line resistor (EOLR) at last device. The end-of-line resistor are supplied with the panel. Install EOLR on all unused circuits.
2. Connect one circuit at a time and apply AC power.
3. Connect batteries to the panel
4. Press ENT to enter PROGRAM mode
5. Press 6 or scroll down to #6 and press ENT, (The selection is indicated by a flashing arrow next to the number.
6. Enter the password. (Factory default is 1111)
7. Press 1 or press ENT. (1 should be the highlighted selection)
8. The display shows the current program number. Press 8 to change to program 8. Press ENT.
9. Press 1 to accept the change.
10. Press ENT to accept the change

| PROGRAM #8                       |   |   |                         |                  |                |                     |        |
|----------------------------------|---|---|-------------------------|------------------|----------------|---------------------|--------|
| For One Sprinkler System         |   |   |                         |                  |                |                     |        |
| Viking Sprinkler System Types    | 1 Release Zone and Manual Release   | 1. FIRECYCLE III Deluge Multicycle System |                         |                  |                |                     |        |
|                                  |   |   |                         |                  |                |                     |        |
| OUTPUTS<br>(Indicating Circuits) | ZONES (Initiating Circuits)   |   |                         |                  |                |                     |        |
|                                  | #1  | #2  | #3                      | #4               | #5             | #6                  | #7     |
|                                  | Supervisory Zone  | Valve Tamper Supervisory Zone             | FIRECYCLE Detector Zone | Supervisory Zone | Waterflow Zone | Manual Release Zone | Unused |
| #1 General Alarm                 |   |   | X                       |                  | X              | X                   |        |
| #2 Supervisory Bell              | X   | X   |                         | X                |                |                     |        |
| #3 Release Solenoid              |   |   | X                       |                  |                | X                   |        |
| #4 N/O Solenoid                  |   |   | X                       |                  | X              |                     |        |
| OPERATION DESCRIPTION            |   |   |                         |                  |                |                     |        |
| Inputs:                          | 1 FIRECYCLE Detection zone, 1 Waterflow zone, 1 Manual Release zone, 3 Supervisory zones  |   |                         |                  |                |                     |        |
| Outputs:                         | 1 General Alarm, 1 Supervisory Bell, 1 Release Solenoid, and 1 N/O Solenoid   |   |                         |                  |                |                     |        |
| Operation:                       | Activation of FIRECYCLE Detector zone #3 will activate output #1 (General Alarm), output #3 (Release Solenoid) and output #4 (N/O Solenoid)     |   |                         |                  |                |                     |        |
|                                  | Activation of Supervisory zone #4 will activate output #2 (Supervisory Bell)  |   |                         |                  |                |                     |        |
|                                  | Activation of Waterflow Alarm zone #5 will activate output #1 (General Alarm) and output #4 (N/O Solenoid)                                      |   |                         |                  |                |                     |        |
|                                  | Activation of Manual Release zone #6 will activate output #1 (General Alarm) and output #3 (Release Solenoid)                                   |   |                         |                  |                |                     |        |
|                                  | Deactivation of FIRECYCLE Detector zone #3 will start soak timer, when timer cycle is complete the output #3 (Release Solenoid) is deactivated. |   |                         |                  |                |                     |        |
|                                  | Activation of Supervisory zone #1 or Valve Tamper Supervisory Zone #2 will activate output #2 (Supervisory Bell)                                |   |                         |                  |                |                     |        |

**NOTES:**

1. Connect EOL Diode assembly IN SERIES as shown with Solenoid on output #3 (Release Solenoid) and output #4 (N/O Solenoid). Black wire to negative terminal on panel and Red wire through Solenoid to positive terminal on panel.
2. Polarity is shown on indicating circuits in an activated (in alarm) condition.
3. Install EOLR (provided) on all unused circuits.
4. See the instruction manual for circuit information, panel limits, and battery sizing.
5. For wire routing instructions through the releasing panel, see Fig 1 on page 2-7 of the instruction manual.
6. See instruction manual for proper programming.
7. See specific system type data page for proper pressure switch settings.
8. Connect EOL resistor after last FIRECYCLE detector on return line to common terminal in FIRECYCLE Detector zone #1.
9. Set the soak timer to desired duration period. Factory setting is continuous. Recommend 60 seconds minimum.
10. Loss of DC power below 20 volt causes output #3 (Release Solenoid) and output #4 (N/O Solenoid) to drop out.
11. Use only Viking FIRECYCLE detectors on FIRECYCLE Detector zone #1.
12. Refer to Viking technical data sheet F\_051404 for Firecycle deluge multi-cycle operation.
13. For UL864 Approved Programming Options, see page 6-102.

PROGRAM #9

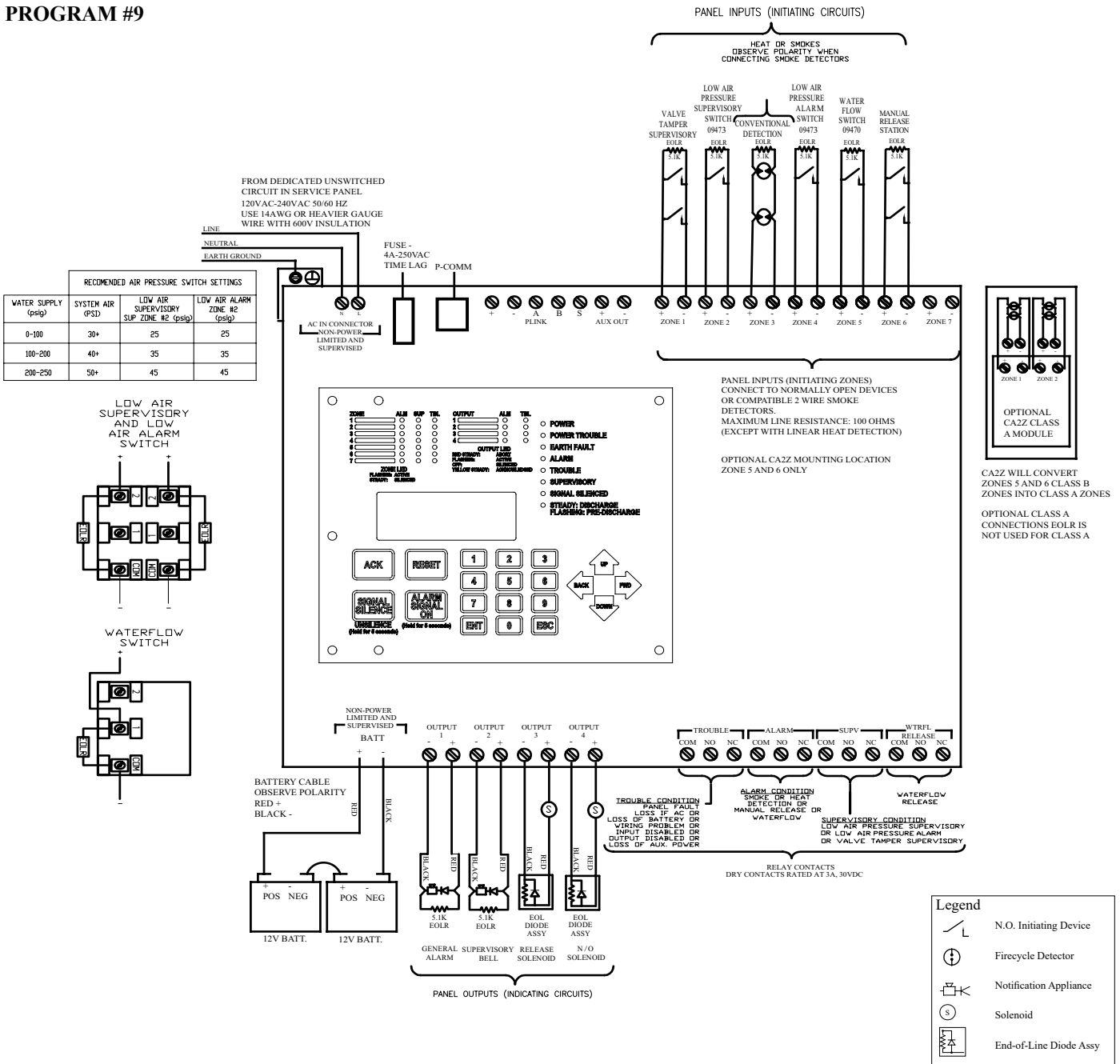

NOTES:

1. Run field wiring and ensure connections are proper by metering wires. Resistance reading should be 5.1K ohms with end-of-line resistor (EOLR) at last device. The end-of-line resistor are supplied with the panel. Install EOLR on all unused circuits.
2. Connect one circuit at a time and apply AC power.
3. Connect batteries to the panel
4. Press ENT to enter PROGRAM mode
5. Press 6 or scroll down to #6 and press ENT, (The selection is indicated by a flashing arrow next to the number.
6. Enter the password. (Factory default is 1111)
7. Press 1 or press ENT. (1 should be the highlighted selection)
8. The display shows the current program number. Press 9 to change to program 9. Press ENT.
9. Press 1 to accept the change.
10. Press ENT to accept the change

| PROGRAM #9                       |   |  |                         |                  |                |                     |        |
|----------------------------------|---|--|-------------------------|------------------|----------------|---------------------|--------|
| For One Sprinkler System         |   |  |                         |                  |                |                     |        |
| Viking Sprinkler System Types    | 1 Release Zone and Manual Release Zone  | 1. FIRECYCLE III Wet Multicycle System |                         |                  |                |                     |        |
|                                  |   |  |                         |                  |                |                     |        |
| OUTPUTS<br>(Indicating Circuits) | ZONES (Initiating Circuits)   |  |                         |                  |                |                     |        |
|                                  | #1  | #2                                     | #3                      | #4               | #5             | #6                  | #7     |
|                                  | Supervisory Zone  | Valve Tamper Supervisory Zone          | FIRECYCLE Detector Zone | Supervisory Zone | Waterflow Zone | Manual Release Zone | Unused |
| #1 General Alarm                 |   |  | X                       |                  | X              | X                   |        |
| #2 Supervisory Bell              | X   | X                                      |                         | X                |                |                     |        |
| #3 Release Solenoid              |   |  | X                       |                  |                | X                   |        |
| #4 N/O Solenoid                  |   |  | X                       |                  | X              |                     |        |
| OPERATION DESCRIPTION            |   |  |                         |                  |                |                     |        |
| Inputs:                          | 1 FIRECYCLE Detection zone, 1 Waterflow zone, 1 Manual Release zone, 3 Supervisory zones  |  |                         |                  |                |                     |        |
| Outputs:                         | 1 General Alarm, 1 Supervisory Bell, 1 Release Solenoid, and 1 N/O Solenoid   |  |                         |                  |                |                     |        |
| Operation:                       | Activation of FIRECYCLE Detector zone #3 will activate output #1 (General Alarm), output #3 (Release Solenoid) and output #4 (N/O Solenoid)     |  |                         |                  |                |                     |        |
|                                  | Activation of Supervisory zone #4 will activate output #2 (Supervisory Bell)  |  |                         |                  |                |                     |        |
|                                  | Activation of Waterflow Alarm zone #5 will activate output #1 (General Alarm) and output #4 (N/O Solenoid)                                      |  |                         |                  |                |                     |        |
|                                  | Activation of Manual Release zone #6 will activate output #1 (General Alarm) and output #3 (Release Solenoid)                                   |  |                         |                  |                |                     |        |
|                                  | Deactivation of FIRECYCLE Detector zone #3 will start soak timer, when timer cycle is complete the output #3 (Release Solenoid) is deactivated. |  |                         |                  |                |                     |        |
|                                  | Activation of Supervisory zone #1 or Valve Tamper Supervisory zone #2 will activate output #2 (Supervisory Bell)                                |  |                         |                  |                |                     |        |

**NOTES:**

1. Connect EOL Diode assembly IN SERIES as shown with Solenoid on output #3 (Release Solenoid) and output #4 (N/O Solenoid). Black wire to negative terminal on panel and Red wire through Solenoid to positive terminal on panel.
2. Polarity is shown on indicating circuits in an activated (in alarm) condition.
3. Install EOLR (provided) on all unused circuits.
4. See the instruction manual for circuit information, panel limits, and battery sizing.
5. For wire routing instructions through the releasing panel, see Fig 1 on page 2-7 of the instruction manual.
6. See instruction manual for proper programming.
7. See specific system type data page for proper pressure switch settings.
8. Connect EOL resistor after last FIRECYCLE detector on return line to common terminal in FIRECYCLE Detector zone #1.
9. Set the soak timer to desired duration period. Factory setting is continuous. Recommend 60 seconds minimum.
10. Loss of DC power below 20 volt causes output #3 (Release Solenoid) and output #4 (N/O Solenoid) to drop out.
11. Use only Viking FIRECYCLE detectors on FIRECYCLE Detector zone #1.
12. Refer to Viking technical data sheet F\_051504 for Firecycle multi-cycle wet system operation.
13. For UL864 Approved Programming Options, see page 6-102.

**PROGRAM #10**

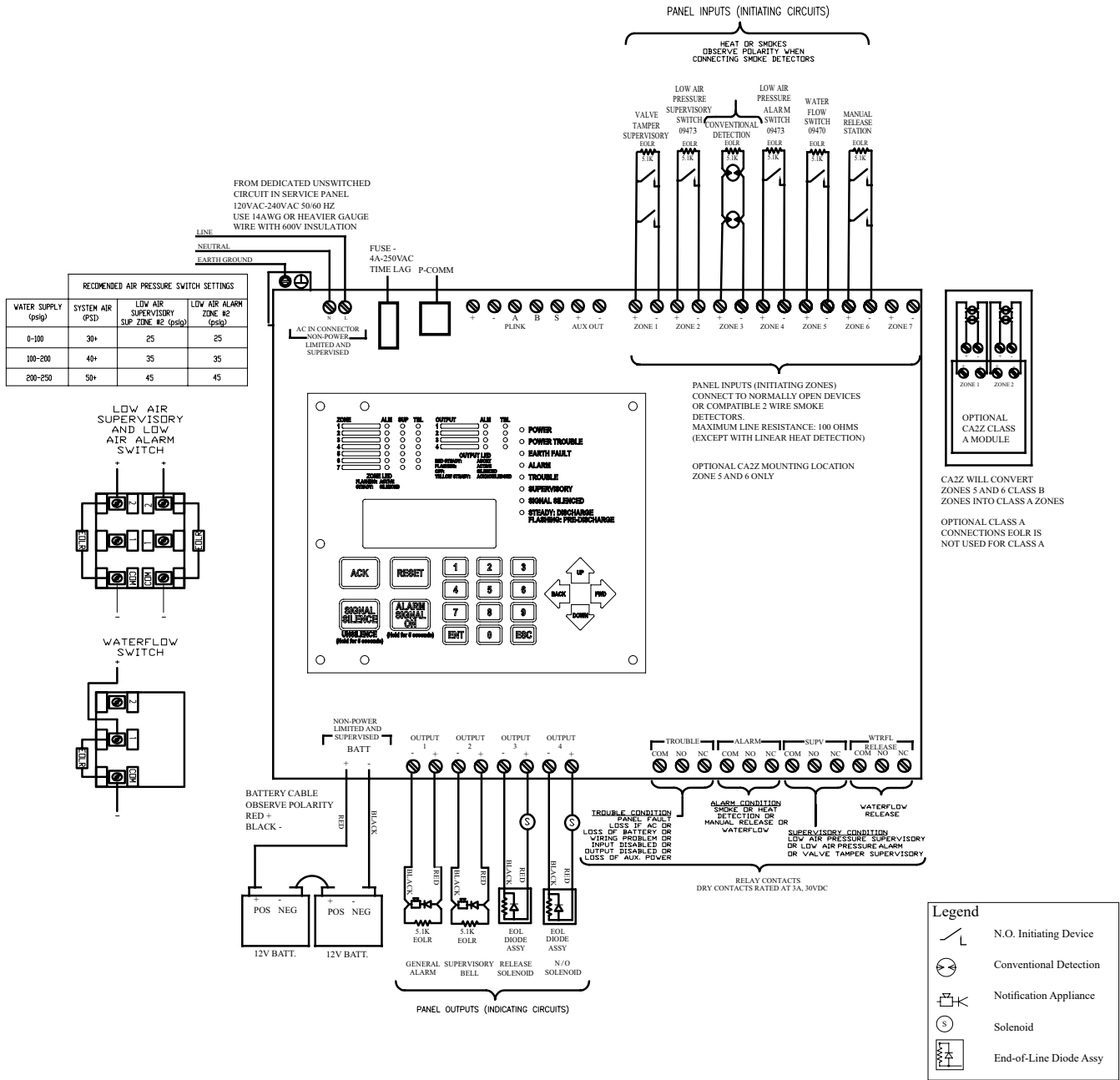

**NOTES:**

1. Run field wiring and ensure connections are proper by metering wires. Resistance reading should be 5.1K ohms with end-offline resistor (EOLR) at last device. The end-of-line resistor are supplied with the panel. Install EOLR on all unused circuits.
2. Connect one circuit at a time and apply AC power.
3. Connect batteries to the panel
4. Press ENT to enter PROGRAM mode
5. Press 6 or scroll down to #6 and press ENT, (The selection is indicated by a flashing arrow next to the number.
6. Enter the password. (Factory default is 1111)
7. Press 1 or press ENT. (1 should be the highlighted selection)
8. The display shows the current program number. Press 10 to change to program 10. Press ENT.
9. Press 1 to accept the change.
10. Press ENT to accept the change



| PROGRAM #10   |   |   |                             |                    |                |                     |        |
|---|---|---|-----------------------------|--------------------|----------------|---------------------|--------|
| For One Sprinkler System- SUREFIRE Single Interlock                       |   |   |                             |                    |                |                     |        |
| Viking Sprinkler System Types   | Release Zone and Manual Release Zone  | 1. SUREFIRE Single Interlocked Preaction System                         |                             |                    |                |                     |        |
|   |   | 2. SUREFIRE Single Interlocked Preaction System - NYC Special           |                             |                    |                |                     |        |
|   |   | 3. SUREFIRE Single Interlocked Preprimed Preaction System               |                             |                    |                |                     |        |
|   |   | 4. SUREFIRE Single Interlocked Preprimed Preaction System - NYC Special |                             |                    |                |                     |        |
| OUTPUTS (Indicating Circuits)   | ZONES (Initiating Circuits)   |   |                             |                    |                |                     |        |
|   | #1  | #2  | #3                          | #4                 | #5             | #6                  | #7     |
|   | Valve Tamper Supervisory Zone   | Low Air Supervisory Zone  | Conventional Detection Zone | Low Air Alarm Zone | Waterflow Zone | Manual Release Zone | Unused |
| #1 General Alarm  |   |   | X                           |                    | X              | X                   |        |
| #2 Supervisory Bell   | X   | X   |                             | X                  |                |                     |        |
| #3 Release Solenoid   |   |   | X                           |                    |                | X                   |        |
| #4 N/O Solenoid   |   |   |                             | X                  |                |                     |        |
| OPERATION DESCRIPTION   |   |   |                             |                    |                |                     |        |
| Inputs:   | 1 Conventional Detection zone, 1 Waterflow zone, 1 Low Air Alarm zone, 1 Manual Release zone, 2 Supervisory zones       |   |                             |                    |                |                     |        |
| Outputs:  | 1 General Alarm, 1 N/O Solenoid, 1 Release Solenoid, 1 Supervisory Bell   |   |                             |                    |                |                     |        |
| Operation:  | Activation of Conventional Detection zone #3 will activate output #3 (Release Solenoid) and output #1 (General Alarm)   |   |                             |                    |                |                     |        |
|   | Activation of Low Air Alarm zone #4 will activate output #2 (Supervisory Bell) and output #4 (N/O Solenoid)             |   |                             |                    |                |                     |        |
|   | Activation of Waterflow zone #5 will activate output #1 (General Alarm)   |   |                             |                    |                |                     |        |
|   | Activation of Manual Release zone #6 will activate output #3 (Release Solenoid) and output #1 (General Alarm)           |   |                             |                    |                |                     |        |
|   | Activation of Valve Tamper Supervisory zone #1 or Low Air Supervisory zone #2 will activate output#2 (Supervisory Bell) |   |                             |                    |                |                     |        |
| A trouble condition will prevent output #4 (N/O Solenoid) from activating |   |   |                             |                    |                |                     |        |

**NOTES:**

1. Connect EOL Diode assembly IN SERIES as shown with Solenoid on output #3 (Release Solenoid) and output #4 (Release Solenoid). Black wire to negative terminal on panel and Red wire through Solenoid to positive terminal on panel.
2. Polarity is shown on indicating circuits in an activated (in alarm) condition.
3. Install EOLR (provided) on all unused circuits.
4. See the instruction manual for circuit information, panel limits, and battery sizing.
5. For wire routing instructions through the releasing panel, see Fig 1 on page 2-7 of the instruction manual.
6. See instruction manual for proper programming.
7. See instruction manual for list of compatible smoke detectors.
8. See specific system type data page for proper pressure switch settings.
9. Loss of DC power below 20 volt causes output #3 (Release Solenoid) and output #4 (N/O Solenoid) to drop out.
10. See Viking technical data sheet F\_051604 for Surefire single interlock operation.

**PROGRAM #11**

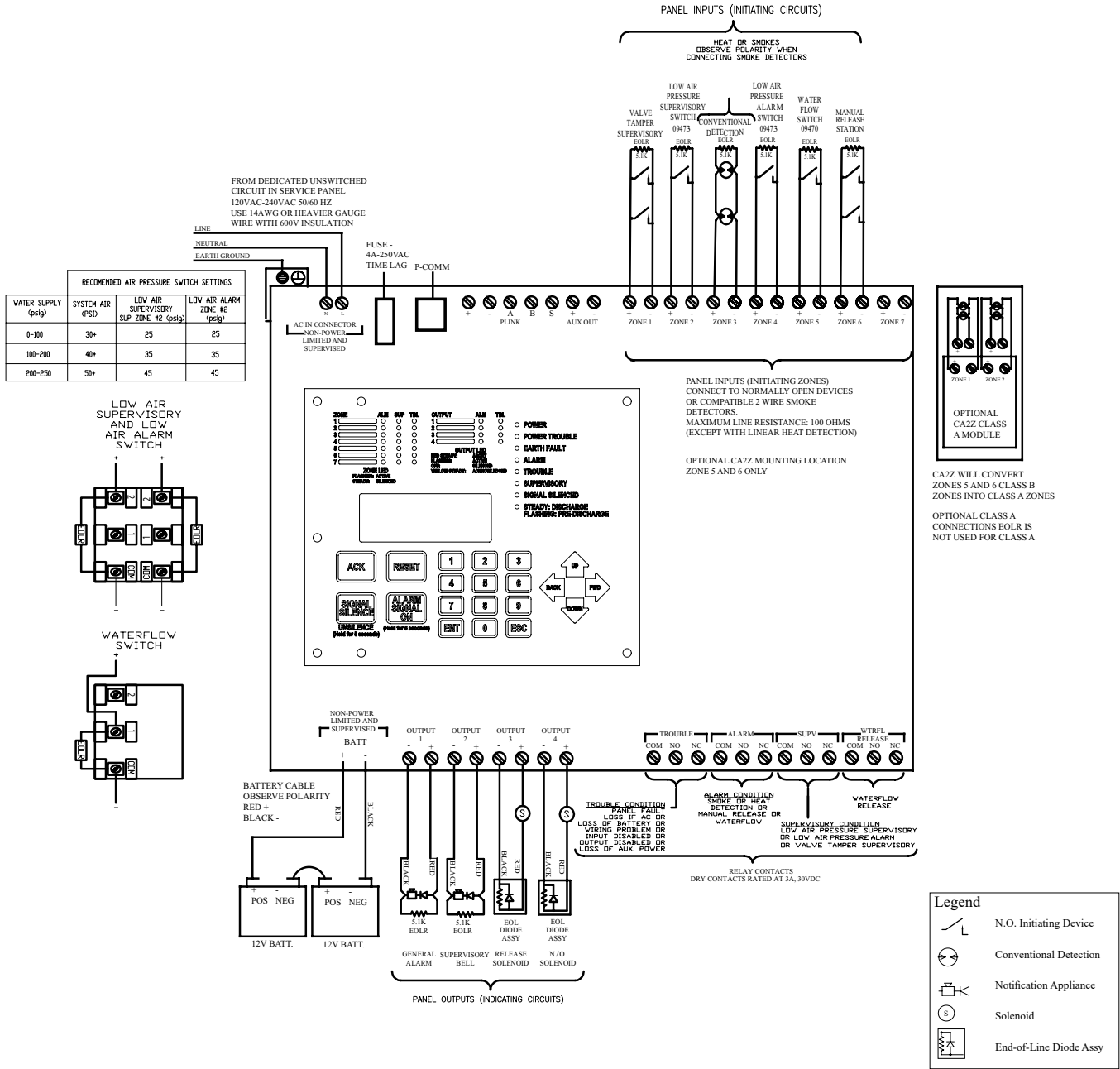

**NOTES:**

1. Run field wiring and ensure connections are proper by metering wires. Resistance reading should be 5.1K ohms with end-offline resistor (EOLR) at last device. The end-of-line resistor are supplied with the panel Install EOLR on all unused circuits.
2. Connect one circuit at a time and apply AC power.
3. Connect batteries to the panel
4. Press ENT to enter PROGRAM mode
5. Press 6 or scroll down to #6 and press ENT, (The selection is indicated by a flashing arrow next to the number.
6. Enter the password. (Factory default is 1111)
7. Press 1 or press ENT. (1 should be the highlighted selection)
8. The display shows the current program number. Press 11 to change to program 11. Press ENT.
9. Press 1 to accept the change.
10. Press ENT to accept the changer

| PROGRAM #11                      |   |   |                             |                    |                |                     |        |                   |
|----------------------------------|---|---|-----------------------------|--------------------|----------------|---------------------|--------|-------------------|
| For One Sprinkler System         |   |   |                             |                    |                |                     |        |                   |
| Viking Sprinkler System Types    | 2 Cross Release Zones and Manual Release Zone   | 1. SUREFIRE Double Interlocked Preaction System                         |                             |                    |                |                     |        |                   |
|                                  |   | 2. SUREFIRE Double Interlocked Preaction System - NYC Special           |                             |                    |                |                     |        |                   |
|                                  |   | 3. SUREFIRE Double Interlocked Preprimed Preaction System               |                             |                    |                |                     |        |                   |
|                                  |   | 4. SUREFIRE Double Interlocked Preprimed Preaction System - NYC Special |                             |                    |                |                     |        |                   |
| OUTPUTS<br>(Indicating Circuits) | ZONES (Initiating Circuits)   |   |                             |                    |                |                     |        | Software Zone     |
|                                  | #1  | #2  | #3                          | #4                 | #5             | #6                  | #7     | #8                |
|                                  | Valve Tamper Supervisory Zone   | Low Air Supervisory Zone  | Conventional Detection Zone | Low Air Alarm Zone | Waterflow Zone | Manual Release Zone | Unused | Release Type Zone |
| #1 General Alarm                 |   |   | X                           |                    | X              | X                   |        | X                 |
| #2 Supervisory Bell              | X   | X   |                             | X                  |                |                     |        |                   |
| #3 Release Solenoid              |   |   | X X                         | X X                |                | X                   |        | XX*               |
| #4 N/O Solenoid                  |   |   |                             | X                  |                |                     |        |                   |
| OPERATION DESCRIPTION            |   |   |                             |                    |                |                     |        |                   |
| Inputs:                          | 1 Conventional Detection zone, 1 Low Air Alarm zone, 1 Waterflow zone, 1 Manual Release zone, 2 Supervisory zones   |   |                             |                    |                |                     |        |                   |
| Outputs:                         | 1 General Alarm, 1 Supervisory Bell, 1 Release Solenoid, 1 N/O Solenoid   |   |                             |                    |                |                     |        |                   |
| Operation:                       | Simultaneous activation of both the Conventional Detection zone #3 and the Low Air Alarm zone #4 will activate output #3 (Release Solenoid), output #1 (General Alarm), output #4 (N/O Solenoid) , and output #2 (Supervisory Bell) |   |                             |                    |                |                     |        |                   |
|                                  | Activation of Conventional Detection zone #3 will activate output #1 (General Alarm)  |   |                             |                    |                |                     |        |                   |
|                                  | Activation of Low Air Alarm zone #4 will activate output #2 (Supervisory Bell) and output #4 (N/O Solenoid)   |   |                             |                    |                |                     |        |                   |
|                                  | Activation of Waterflow zone #6 will activate output #1 (General Alarm)   |   |                             |                    |                |                     |        |                   |
|                                  | Activation of Valve Tamper Supervisory zone #1 or Low Air Supervisory zone #2 will activate output#2 (Supervisory Bell)   |   |                             |                    |                |                     |        |                   |
|                                  | Activation of Manual Release zone #4 will activate output #3 (Release Solenoid) and output #1 (General Alarm)   |   |                             |                    |                |                     |        |                   |
|                                  | A trouble condition will prevent output #4 (N/O Solenoid) from activating   |   |                             |                    |                |                     |        |                   |

**\* Release Outputs which are Cross-Zoned need a Software Zone in order to work properly. The Software Zone Number will be displayed upon a release.**

XX = Cross-Zoned

**NOTES:**

1. Connect EOL Diode assembly IN SERIES as shown with Solenoid on output #3 (Release Solenoid) and output #4 (Release Solenoid). Black wire to negative terminal on panel and Red wire through Solenoid to positive terminal on panel.
2. Polarity is shown on indicating circuits in an activated (in alarm) condition.
3. Install EOLR (provided) on all unused circuits.
4. See the instruction manual for circuit information, panel limits, and battery sizing.
5. For wire routing instructions through the releasing panel, see Fig 1 on page 2-7 of the instruction manual.
6. See instruction manual for proper programming.
7. See instruction manual for list of compatible smoke detectors.
8. See specific system type data page for proper pressure switch settings.
9. Loss of DC power below 20 volt causes output #3 (Release Solenoid) and output #4 (N/O Solenoid) to drop out.
10. See Viking technical data sheet F\_051704 for Surefire double interlock operation.

**PROGRAM #12**

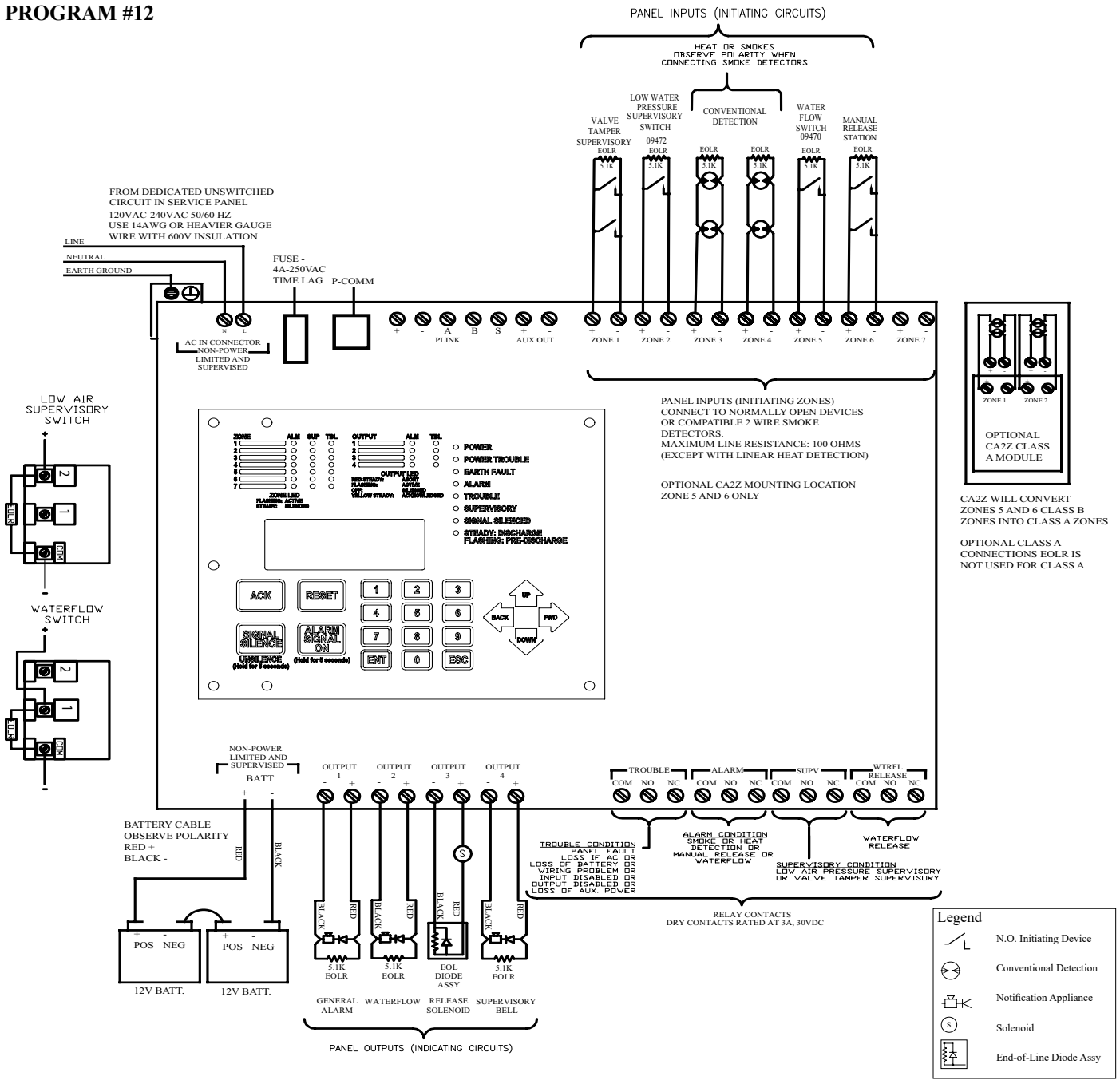

**NOTES:**

1. Run field wiring and ensure connections are proper by metering wires. Resistance reading should be 5.1K ohms with end-offline resistor (EOLR) at last device. The end-of-line resistor are supplied with the panel Install EOLR on all unused circuits.
2. Connect one circuit at a time and apply AC power.
3. Connect batteries to the panel
4. Press ENT to enter PROGRAM mode
5. Press 6 or scroll down to #6 and press ENT, (The selection is indicated by a flashing arrow next to the number.
6. Enter the password. (Factory default is 1111)
7. Press 1 or press ENT. (1 should be the highlighted selection)
8. The display shows the current program number. Press 12 to change to program 12. Press ENT.
9. Press 1 to accept the change.
10. Press ENT to accept the change

| PROGRAM #12  |   |   |                             |                             |                |                     |        |                   |
|--|---|---|-----------------------------|-----------------------------|----------------|---------------------|--------|-------------------|
| For One Sprinkler System   |   |   |                             |                             |                |                     |        |                   |
| Viking Sprinkler System Types  | 2 Cross Release Zones, Waterflow Zone, and Manual Release Zone  | 1. Single Interlocked Preaction System with Electric Release              |                             |                             |                |                     |        |                   |
|  |   | 2. Deluge System with Electric Release                                    |                             |                             |                |                     |        |                   |
|  |   | 3. Non-Interlocked Preaction system with Electric Release                 |                             |                             |                |                     |        |                   |
|  |   | 4. Double Interlocked Preaction System with Electric/Pneu-Lectric Release |                             |                             |                |                     |        |                   |
| OUTPUTS<br>(Indicating Circuits)   | ZONES (Initiating Circuits)   |   |                             |                             |                |                     |        | Software Zone     |
|  | #1  | #2  | #3                          | #4                          | #5             | #6                  | #7     | #                 |
|  | Valve Tamper Supervisory Zone   | Low Air Supervisory Zone  | Conventional Detection Zone | Conventional Detection Zone | Waterflow Zone | Manual Release Zone | Unused | Release Type Zone |
| #1 General Alarm   |   |   | X                           | X                           | X              | X                   |        | X                 |
| #2 Waterflow   |   |   |                             |                             | X              |                     |        |                   |
| #3 Release Solenoid  |   |   | X X                         | X X                         |                | X                   |        | XX*               |
| #4 Supervisory Bell  | X   | X   |                             |                             |                |                     |        |                   |
| OPERATION DESCRIPTION  |   |   |                             |                             |                |                     |        |                   |
| Inputs:  | 2 Conventional Detection zones, 1 Waterflow zone, 1 Manual Release zone, 2 Supervisory zones  |   |                             |                             |                |                     |        |                   |
| Outputs:   | 1 General Alarm, 1 Waterflow, 1 Release Solenoid, 1 Supervisory Bell  |   |                             |                             |                |                     |        |                   |
| Operation:   | Simultaneous activation of both the Conventional Detection zone #3 and the Conventional Detector zone #4 will activate output #3 (Release Solenoid) and output #1 (General Alarm) |   |                             |                             |                |                     |        |                   |
|  | Activation of Conventional Detection zone #3 will activate output #1 (General Alarm)  |   |                             |                             |                |                     |        |                   |
|  | Activation of Conventional Detection zone #4 will activate output #1 (General Alarm)  |   |                             |                             |                |                     |        |                   |
|  | Activation of Waterflow zone #5 will activate output #2 (Waterflow) and output #1 (General Alarm)   |   |                             |                             |                |                     |        |                   |
|  | Activation of Manual Release zone #6 will activate output #3 (Release Solenoid) and output #1 (General Alarm)   |   |                             |                             |                |                     |        |                   |
| Activation of Valve Tamper Supervisory zone #1 or Low Air Supervisory zone #2 will activate output #4 (Supervisory Bell) |   |   |                             |                             |                |                     |        |                   |

\* Release Outputs which are Cross-Zoned need a Software Zone in order to work properly. The Software Zone Number will be displayed upon a release.

XX = Cross-Zoned

**NOTES:**

1. Connect EOL Diode assembly IN SERIES as shown with Solenoid on output #3 (Release Solenoid). Black wire to negative terminal on panel and Red wire through Solenoid to positive terminal on panel.
2. Polarity is shown on indicating circuits in an activated (in alarm) condition.
3. Install EOLR (provided) on all unused circuits.
4. See the instruction manual for circuit information, panel limits, and battery sizing.
5. For wire routing instructions through the releasing panel, see Fig 1 on page 2-7 of the instruction manual.
6. See instruction manual for proper programming.
7. See instruction manual for list of compatible smoke detectors.
8. See specific system type data page for proper pressure switch settings.

**PROGRAM #13**

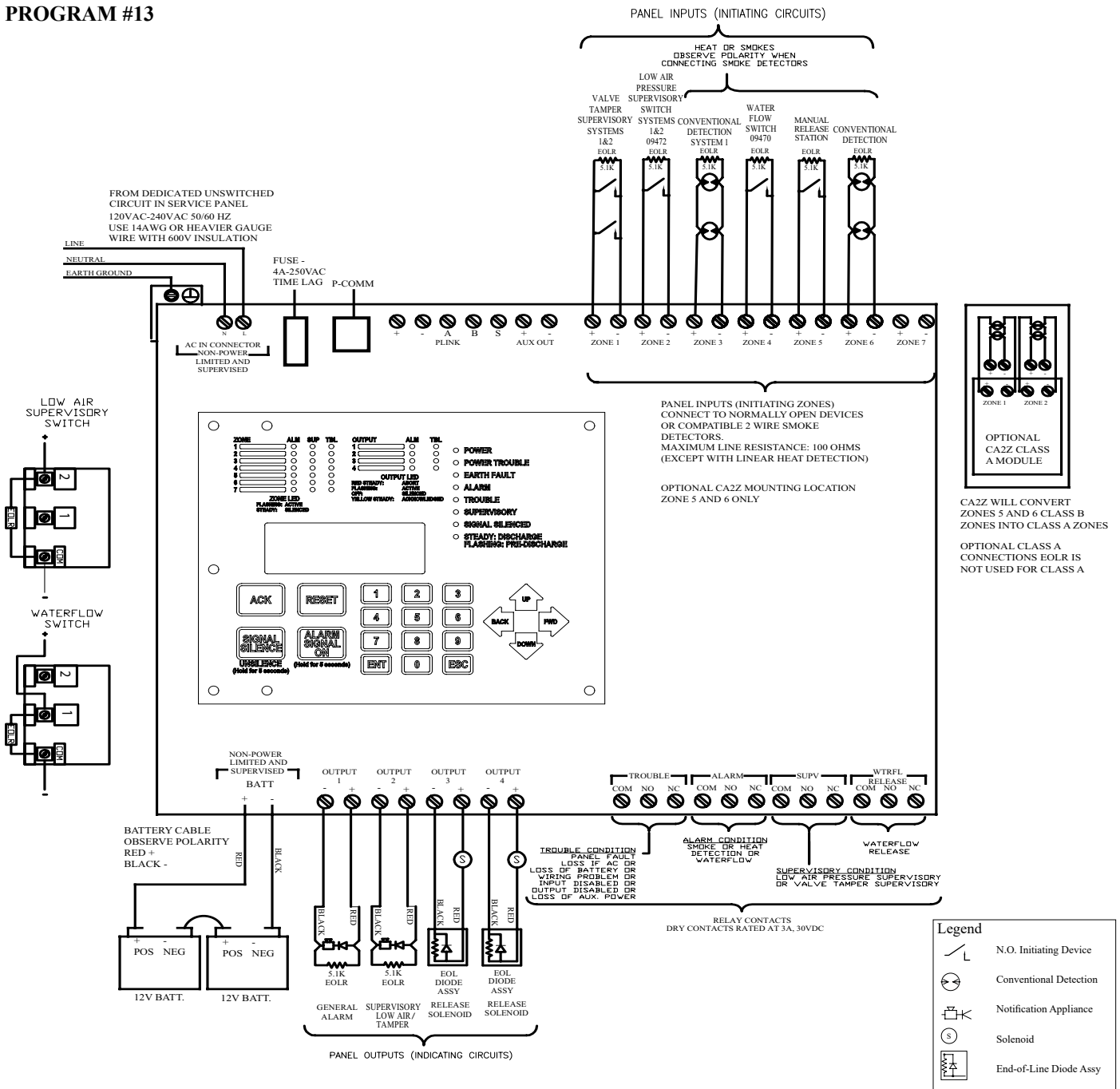

**NOTES:**

1. Run field wiring and ensure connections are proper by metering wires. Resistance reading should be 5.1K ohms with end-offline resistor (EOLR) at last device. The end-of-line resistor are supplied with the panel. Install EOLR on all unused circuits.
2. Connect one circuit at a time and apply AC power.
3. Connect batteries to the panel
4. Press ENT to enter PROGRAM mode
5. Press 6 or scroll down to #6 and press ENT, (The selection is indicated by a flashing arrow next to the number.)
6. Enter the password. (Factory default is 1111)
7. Press 1 or press ENT. (1 should be the highlighted selection)
8. The display shows the current program number. Press 13 to change to program 13. Press ENT.
9. Press 1 to accept the change.
10. Press ENT to accept the change

| PROGRAM #13                             |  |   |                             |                |                     |                             |        |
|---|--|---|-----------------------------|----------------|---------------------|-----------------------------|--------|
| For One Sprinkler System                |  |   |                             |                |                     |                             |        |
| Viking Sprinkler System Types (UK only) | 2 Release Zones, Waterflow Zone, and Manual Release Zone   | E-1 Single-interlocked preaction system with Electric-Pneumatic release |                             |                |                     |                             |        |
| OUTPUTS<br>(Indicating Circuits)        | ZONES (Initiating Circuits)  |   |                             |                |                     |                             |        |
|   | #1   | #2  | #3                          | #4             | #5                  | #6                          | #7     |
|   | Valve Tamper Supervisory Zone  | Low Air Supervisory Zone  | Conventional Detection Zone | Waterflow Zone | Manual Release Zone | Conventional Detection Zone | Unused |
| #1 General Alarm                        |  |   | X                           | X              | X                   | X                           |        |
| #2 Low air/Tamper                       | X  | X   |                             |                |                     |                             |        |
| #3 Release Solenoid #1                  |  |   | X                           |                | X                   | X                           |        |
| #4 Release Solenoid #2                  |  |   | X                           |                | X                   | X                           |        |
| OPERATION DESCRIPTION                   |  |   |                             |                |                     |                             |        |
| Inputs:                                 | 2 Conventional Detection zones, 1 Waterflow zone, 1 Manual Release zone, 2 Supervisory zones   |   |                             |                |                     |                             |        |
| Outputs:                                | 1 General Alarm, 1 Low Air/Tamper, 2 Release Solenoids   |   |                             |                |                     |                             |        |
| Operation:                              | Activation of Conventional Detection zone #3 or #6 or manual release zone #5 will activate outputs #3 and #4 (release solenoids) and output #1 (General Alarm) |   |                             |                |                     |                             |        |
|   | Activation of Waterflow zone #4 will activate output #1 (General Alarm)  |   |                             |                |                     |                             |        |
|   | Activation of Valve Tamper supervisory zone #1 or Low air supervisory zone #2 will activate output #2 (Low Air/Tamper)   |   |                             |                |                     |                             |        |

**NOTES:**

1. Connect EOL Diode assembly IN SERIES as shown with solenoids on outputs #3 and #4. Black wire to negative terminal on panel. Red wire through solenoid to positive terminal on panel.
2. Polarity is shown on indicating circuits in an activated (in alarm) condition.
3. Install EOLR (provided) on all unused circuits.
4. See the instruction manual for circuit information, panel limits, and battery sizing.
5. For wire routing instructions through the releasing panel, see Fig 1 on page 2-7 of the instruction manual.
6. See instruction manual for proper programming.
7. See instruction manual for list of compatible smoke detectors and solenoids.
8. See specific system type data page for proper pressure switch settings.
9. For UL864 Approved Programming Options, see page 6-102.

**PROGRAM #14**

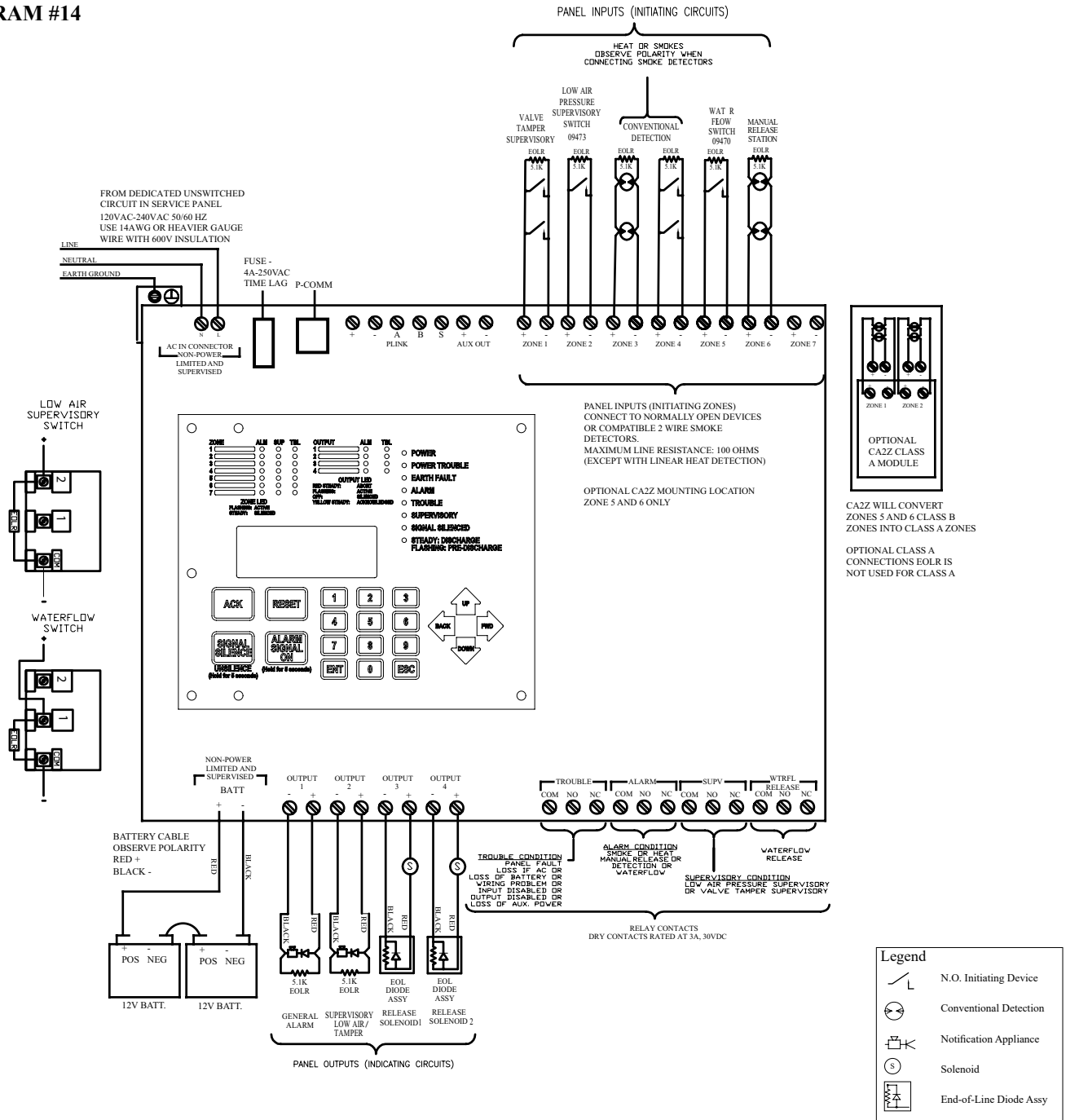

**NOTES:**

1. Run field wiring and ensure connections are proper by metering wires. Resistance reading should be 5.1K ohms with end-offline resistor (EOLR) at last device. The end-of-line resistor are supplied with the panel. Install EOLR on all unused circuits.
2. Connect one circuit at a time and apply AC power.
3. Connect batteries to the panel
4. Press ENT to enter PROGRAM mode
5. Press 6 or scroll down to #6 and press ENT, (The selection is indicated by a flashing arrow next to the number.)
6. Enter the password. (Factory default is 1111)
7. Press 1 or press ENT. (1 should be the highlighted selection)
8. The display shows the current program number. Press 14 to change to program 14. Press ENT.
9. Press 1 to accept the change.
10. Press ENT to accept the change



| PROGRAM #14                             |  |   |                             |                             |                |                     |        |                   |
|---|--|---|-----------------------------|-----------------------------|----------------|---------------------|--------|-------------------|
| For One Sprinkler System                |  |   |                             |                             |                |                     |        |                   |
| Viking Sprinkler System Types (UK only) | 2 Cross Release Zones, Waterflow Zone, and Manual Release Zone   | E-1 Single-interlocked preaction system with Electric - Pneumatic release |                             |                             |                |                     |        |                   |
| OUTPUTS<br>(Indicating Circuits)        | ZONES (Initiating Circuits)  |   |                             |                             |                |                     |        | Software Zone     |
|   | #1   | #2  | #3                          | #4                          | #5             | #6                  | #7     | #8                |
|   | Valve Tamper Supervisory Zone  | Low Air Supervisory Zone  | Conventional Detection Zone | Conventional Detection Zone | Waterflow Zone | Manual Release Zone | Unused | Release Type Zone |
| #1 General Alarm                        |  |   | X                           | X                           | X              | X                   |        | X                 |
| #2 Supervisory Bell                     | X  | X   |                             |                             |                |                     |        |                   |
| #3 Release Solenoid #1                  |  |   | XX                          | XX                          |                | X                   |        | XX*               |
| #4 Release Solenoid #2                  |  |   | XX                          | XX                          |                | X                   |        | XX*               |
| OPERATION DESCRIPTION                   |  |   |                             |                             |                |                     |        |                   |
| Inputs:                                 | 2 Conventional Detection zones, 1 Waterflow zone, 1 Manual Release zone, 2 Supervisory zones   |   |                             |                             |                |                     |        |                   |
| Outputs:                                | 1 General Alarm, 1 Low Air/Tamper, 2 Release Solenoids   |   |                             |                             |                |                     |        |                   |
| Operation:                              | Activation of both Conventional Detection zone #3 and #4 or manual release zone #6 will activate outputs #3 and #4 (release solenoids) and output #1 (General Alarm) |   |                             |                             |                |                     |        |                   |
|   | Activation of Waterflow zone #3 will activate output #1 (General Alarm)  |   |                             |                             |                |                     |        |                   |
|   | Activation of Valve Tamper supervisory zone #1 or Low air supervisory zone #2 will activate output #2 (Low Air/Tamper)   |   |                             |                             |                |                     |        |                   |

\* Release Outputs which are Cross-Zoned need a Software Zone in order to work properly. The Software Zone Number will be displayed upon a release.

XX = Cross-Zoned

**NOTES:**

1. Connect EOL Diode assembly IN SERIES as shown with solenoids on outputs #3 and #4. Black wire to negative terminal on panel. Red wire through solenoid to positive terminal on panel.
2. Polarity is shown on indicating circuits in an activated (in alarm) condition.
3. Install EOLR (provided) on all unused circuits.
4. See the instruction manual for circuit information, panel limits, and battery sizing.
5. For wire routing instructions through the releasing panel, see Fig 1 on page 2-7 of the instruction manual.
6. See instruction manual for proper programming.
7. See instruction manual for list of compatible smoke detectors and solenoids.
8. See specific system type data page for proper pressure switch settings.
9. For UL864 Approved Programming Options, see page 6-102.

**PROGRAM #15**

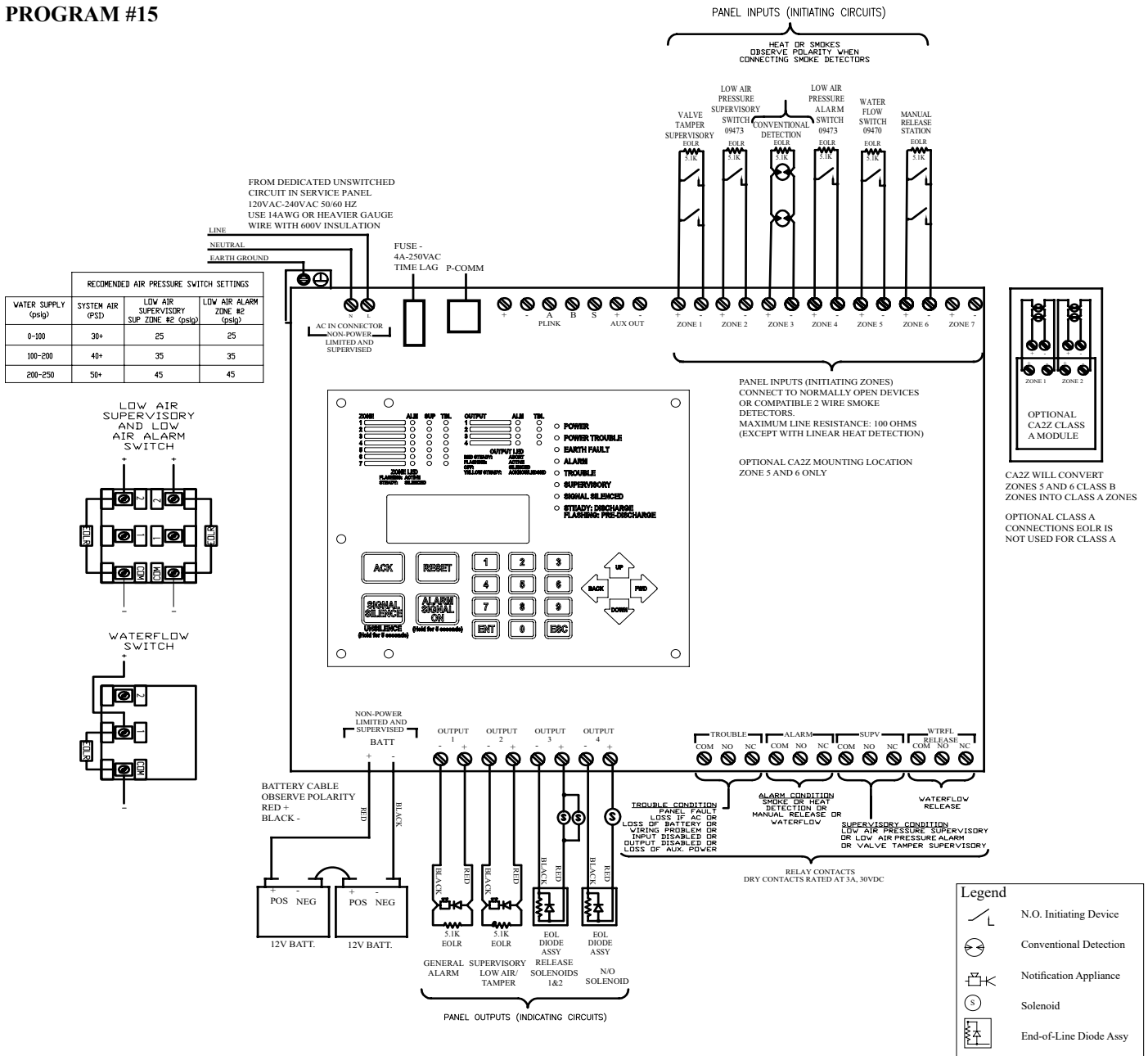

**NOTES:**

1. Run field wiring and ensure connections are proper by metering wires. Resistance reading should be 5.1K ohms with end-offline resistor (EOLR) at last device. The end-of-line resistor are supplied with the panel Install EOLR on all unused circuits.
2. Connect one circuit at a time and apply AC power.
3. Connect batteries to the panel
4. Press ENT to enter PROGRAM mode
5. Press 6 or scroll down to #6 and press ENT, (The selection is indicated by a flashing arrow next to the number.
6. Enter the password. (Factory default is 1111)
7. Press 1 or press ENT. (1 should be the highlighted selection)
8. The display shows the current program number. Press 15 to change to program 15. Press ENT.
9. Press 1 to accept the change.
10. Press ENT to accept the change

Note: Release solenoids #1 and #2 shall be wired in parallel and connected to output #3. the wiring shall be in conduit otherwise protected. Any connections shall be made in a junction box. This may not conform to the monitoring for integrity requirements for NFPA 72.

| PROGRAM #15                             |  |  |                             |                    |                |                     |        |
|---|--|--|-----------------------------|--------------------|----------------|---------------------|--------|
| For One Sprinkler System                |  |  |                             |                    |                |                     |        |
| Viking Sprinkler System Types (UK only) | 2 Release Zones, Waterflow Zone, and Manual Release Zone   | E-1 Single-interlocked Surefire preaction system with Electric-Pneumatic release |                             |                    |                |                     |        |
| OUTPUTS (Indicating Circuits)           | ZONES (Initiating Circuits)  |  |                             |                    |                |                     |        |
|   | #1   | #2   | #3                          | #4                 | #5             | #6                  | #7     |
|   | Valve Tamper Supervisory Zone  | Low Air Supervisory Zone   | Conventional Detection Zone | Low Air Alarm Zone | Waterflow Zone | Manual Release Zone | Unused |
| #1 General Alarm                        |  |  | X                           |                    | X              | X                   |        |
| #2 Low air/Tamper                       | X  | X  |                             | X                  |                |                     |        |
| #3 Release Solenoids #1 & #2            |  |  | X                           |                    |                | X                   |        |
| #4 N/O Solenoid                         |  |  |                             | X                  |                |                     |        |
| OPERATION DESCRIPTION                   |  |  |                             |                    |                |                     |        |
| Inputs:                                 | 1 Conventional Detection zone, 1 Low air alarm zone, 1 Waterflow zone, 1 Manual Release zone, 2 Supervisory zones                                |  |                             |                    |                |                     |        |
| Outputs:                                | 1 General Alarm, 1 Low Air/Tamper, 2 Release Solenoids (single output from panel), 1 N/O solenoid  |  |                             |                    |                |                     |        |
| Operation:                              | Activation of Conventional Detection zone #3 or manual release zone #6 will activate output #3 (release solenoids) and output #1 (General Alarm) |  |                             |                    |                |                     |        |
|   | Activation of Low Air Alarm zone #4 will activate output #2 Low air/tamper and output #4 (N/O solenoid)  |  |                             |                    |                |                     |        |
|   | Activation of Waterflow zone #5 will activate output #1 (General Alarm)  |  |                             |                    |                |                     |        |
|   | Activation of Valve Tamper supervisory zone #1, Low air supervisory zone #2, or Low Air alarm zone #2 will activate output #2 (Low Air/Tamper)   |  |                             |                    |                |                     |        |
|   | A trouble condition will prevent output #4 (N/O) from activating   |  |                             |                    |                |                     |        |

**NOTES:**

1. Connect EOL Diode assembly IN SERIES as shown with solenoids on outputs #3 and #4. Black wire to negative terminal on panel. Red wire through solenoid to positive terminal on panel. Output #3 has 2 solenoids. These must be connected in parallel and the EOL diode is connected in series with the parallel solenoids.
2. Polarity is shown on indicating/release circuits in an activated (in alarm) condition.
3. Install EOLR (provided) on all unused circuits.
4. See the instruction manual for circuit information, panel limits, and battery sizing.
5. For wire routing instructions through the releasing panel, see Fig 1 on page 2-7 of the instruction manual.
6. See instruction manual for proper programming.
7. See instruction manual for list of compatible smoke detectors and solenoids.
8. See specific system type data page for proper pressure switch settings.
9. Loss of power below 20 volts causes output #3 (release solenoids) and output #4 (N/O solenoid) to drop out.
10. See Viking technical data sheet F\_051604 for Surefire single interlock operation.
11. For UL864 Approved Programming Options, see page 6-102.

**PROGRAM #16**

| EXTRA HAZARD APPLICATIONS   |          |                          |          | ORDINARY & LIGHT HAZARD APP.   |          |                 |          |
|-----------------------------|----------|--------------------------|----------|--------------------------------|----------|-----------------|----------|
| FIRECYCLE DETECTORS MODEL B |          |                          |          | FIRECYCLE OH DETECTORS MODEL C |          |                 |          |
| WITH 04632A CABLE           |          | WITH FPL WIRE IN CONDUIT |          | FLUSH MOUNTED                  |          | SURFACE MOUNTED |          |
| TEMP. F°                    | PART NO. | TEMP. F°                 | PART NO. | TEMP. F°                       | PART NO. | TEMP. F°        | PART NO. |
| 140                         | 0471A    | 140                      | 08288    | 140                            | 11723    | 140             | 11727    |
| 160                         | 0471A    | 160                      | 08289    | 160                            | 11724    | 160             | 11728    |
| 190                         | 0471B    | 190                      | 08290    | 190                            | 11725    | 190             | 11729    |
| 225                         | 0471B    | 225                      | 08291    | 225                            | 11726    | 225             | 11730    |

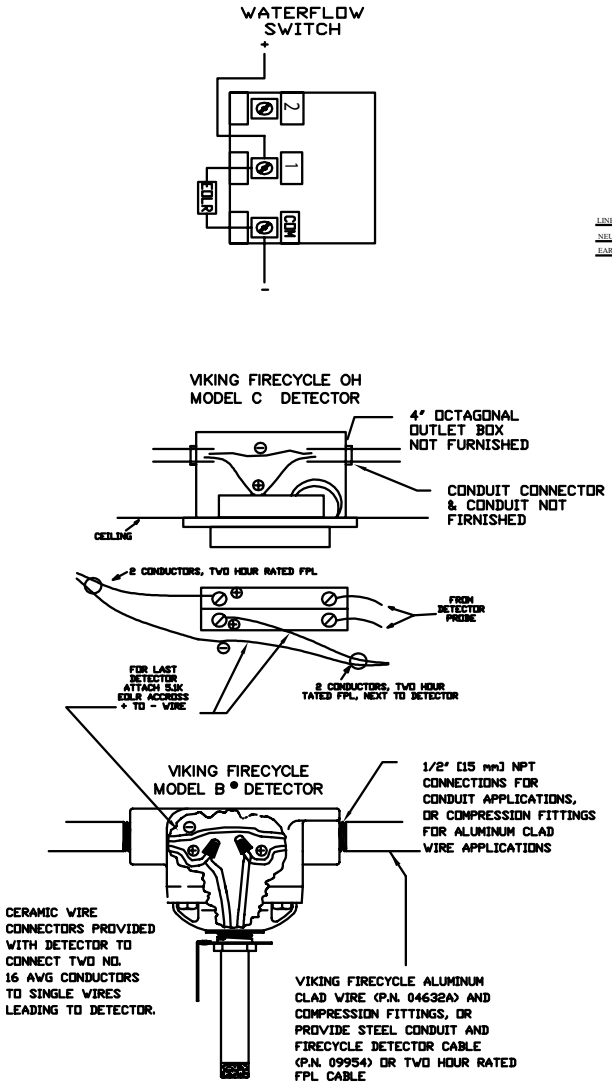
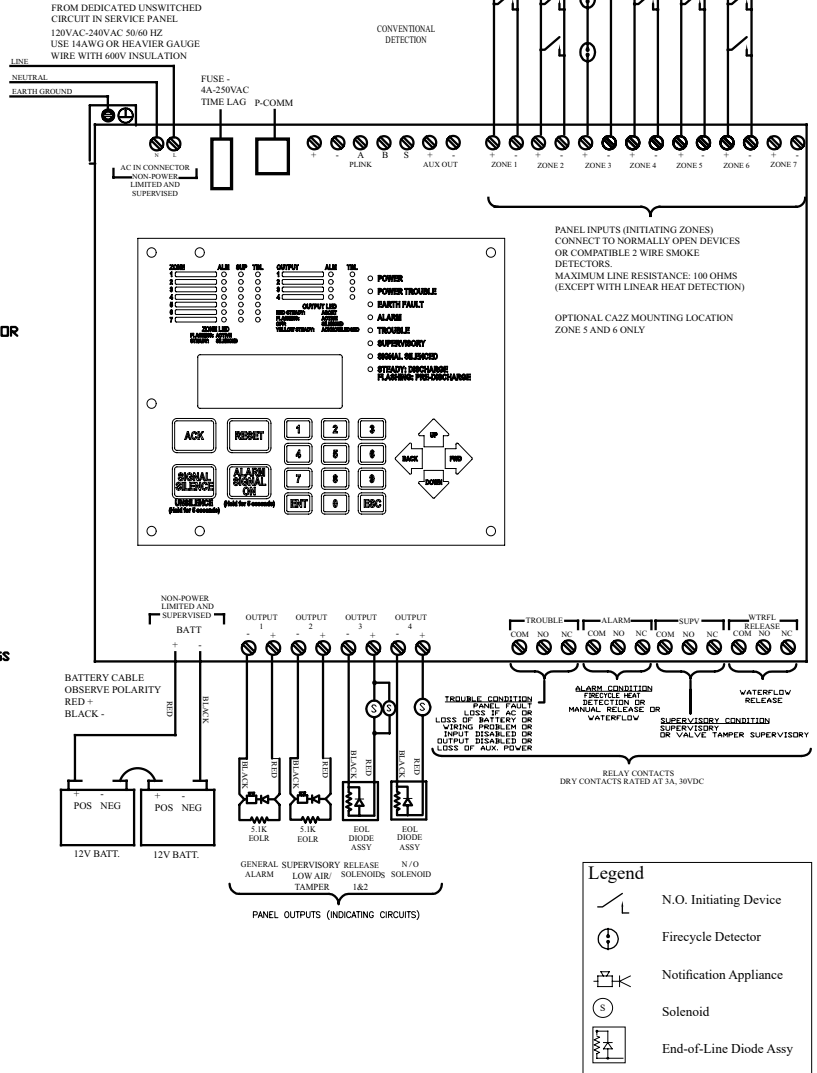

**NOTES:**

1. Run field wiring and ensure connections are proper by metering wires. Resistance reading should be 5.1K ohms with end-offline resistor (EOLR) at last device. The end-of-line resistor are supplied with the panel Install EOLR on all unused circuits.
2. Connect one circuit at a time and apply AC power.
3. Connect batteries to the panel
4. Press ENT to enter PROGRAM mode
5. Press 6 or scroll down to #6 and press ENT, (The selection is indicated by a flashing arrow next to the number.
6. Enter the password. (Factory default is 1111)
7. Press 1 or press ENT. (1 should be the highlighted selection)
8. The display shows the current program number. Press 16 to change to program 16. Press ENT.
9. Press 1 to accept the change.
10. Press ENT to accept the change

Note: Release solenoids #1 and #2 shall be wired in parallel and connected to output #3. the wiring shall be in conduit or otherwise protected. Any connections shall be made in a junction box. This may not conform to the monitoring for integrity requirements for NFPA 72.

| PROGRAM #16                             |   |   |                          |                    |                |                     |        |
|---|---|---|--------------------------|--------------------|----------------|---------------------|--------|
| For One Sprinkler System                |   |   |                          |                    |                |                     |        |
| Viking Sprinkler System Types (UK only) | 2 Release Zones, Waterflow Zone, and Manual Release Zone  | E-1 Single-interlocked Firecycle III preaction system with Electric-Pneumatic release |                          |                    |                |                     |        |
| OUTPUTS (Indicating Circuits)           | ZONES (Initiating Circuits)   |   |                          |                    |                |                     |        |
|   | #1  | #2  | #3                       | #4                 | #5             | #6                  | #7     |
|   | Valve Tamper Supervisory Zone   | Low Air Supervisory Zone  | Firecycle Detection Zone | Low Air Alarm Zone | Waterflow Zone | Manual Release Zone | Unused |
| #1 General Alarm                        |   |   | X                        |                    | X              | X                   |        |
| #2 Low air/Tamper                       | X   | X   |                          | X                  |                |                     |        |
| #3 Release Solenoids #1 & #2            |   |   | X                        |                    |                | X                   |        |
| #4 N/O Solenoid                         |   |   | X                        | X                  | X              |                     |        |
| OPERATION DESCRIPTION                   |   |   |                          |                    |                |                     |        |
| Inputs:                                 | 1 Firecycle Detection zone, 1 Low air alarm zone, 1 Waterflow zone, 1 Manual Release zone, 2 Supervisory zones                                    |   |                          |                    |                |                     |        |
| Outputs:                                | 1 General Alarm, 1 Low Air/Tamper, 2 Release Solenoids (single output from panel), 1 N/O solenoid   |   |                          |                    |                |                     |        |
| Operation:                              | Activation of Firecycle Detection zone #3 will activate output #3 (release solenoids), output #1 (General Alarm), and output #4 (N/O solenoid)    |   |                          |                    |                |                     |        |
|   | Activation of Low air alarm zone #4 will activate output #2 (Low air/Tamper) and output #4 (N/O solenoid)   |   |                          |                    |                |                     |        |
|   | Activation of Waterflow Zone #5 will activate output #1 (General Alarm) and output #4 (N/O solenoid)  |   |                          |                    |                |                     |        |
|   | Activation of manual release zone #6 will activate output #3 (release solenoids) and output #1 (General Alarm)                                    |   |                          |                    |                |                     |        |
|   | Deactivation of the Firecycle Detector Zone #3 will start soak timer. When timer cycle is complete, output #3 (release solenoids) is deactivated. |   |                          |                    |                |                     |        |
|   | Activation of Valve Tamper supervisory zone #1, Low air supervisory zone #2, or Low air alarm #2 will operate output #2 (Low air/Tamper)          |   |                          |                    |                |                     |        |

**NOTES:**

1. Connect EOL Diode assembly IN SERIES as shown with solenoids on outputs #3 and #4. Black wire to negative terminal on panel. Red wire through solenoid to positive terminal on panel. Output #3 has 2 solenoids. These must be connected in parallel and the EOL diode is connected in series with the parallel solenoids.
2. Polarity is shown on indicating/release circuits in an activated (in alarm) condition.
3. Install EOLR (provided) on all unused circuits.
4. See the instruction manual for circuit information, panel limits, and battery sizing.
5. For wire routing instructions through the releasing panel, see Fig 1 on page 2-7 of the instruction manual.
6. See instruction manual for proper programming.
7. See instruction manual for list of compatible smoke detectors and solenoids.
8. See specific system type data page for proper pressure switch settings.
9. Connect EOL resistor IN SERIES after LAST Firecycle detector on return line to common terminal in Firecycle detector zone #1.
10. Set the soak timer to desired duration period. Factory setting is continuous. Recommended time is 60 seconds, minimum.
11. Loss of power below 20 volts causes output #3 (release solenoids) and output #4 (N/O solenoid) to drop out.
12. See Viking technical data sheet F\_051404 for Firecycle deluge multi-cycle system.
13. For UL864 Approved Programming Options, see page 6-102.

**PROGRAM #17**

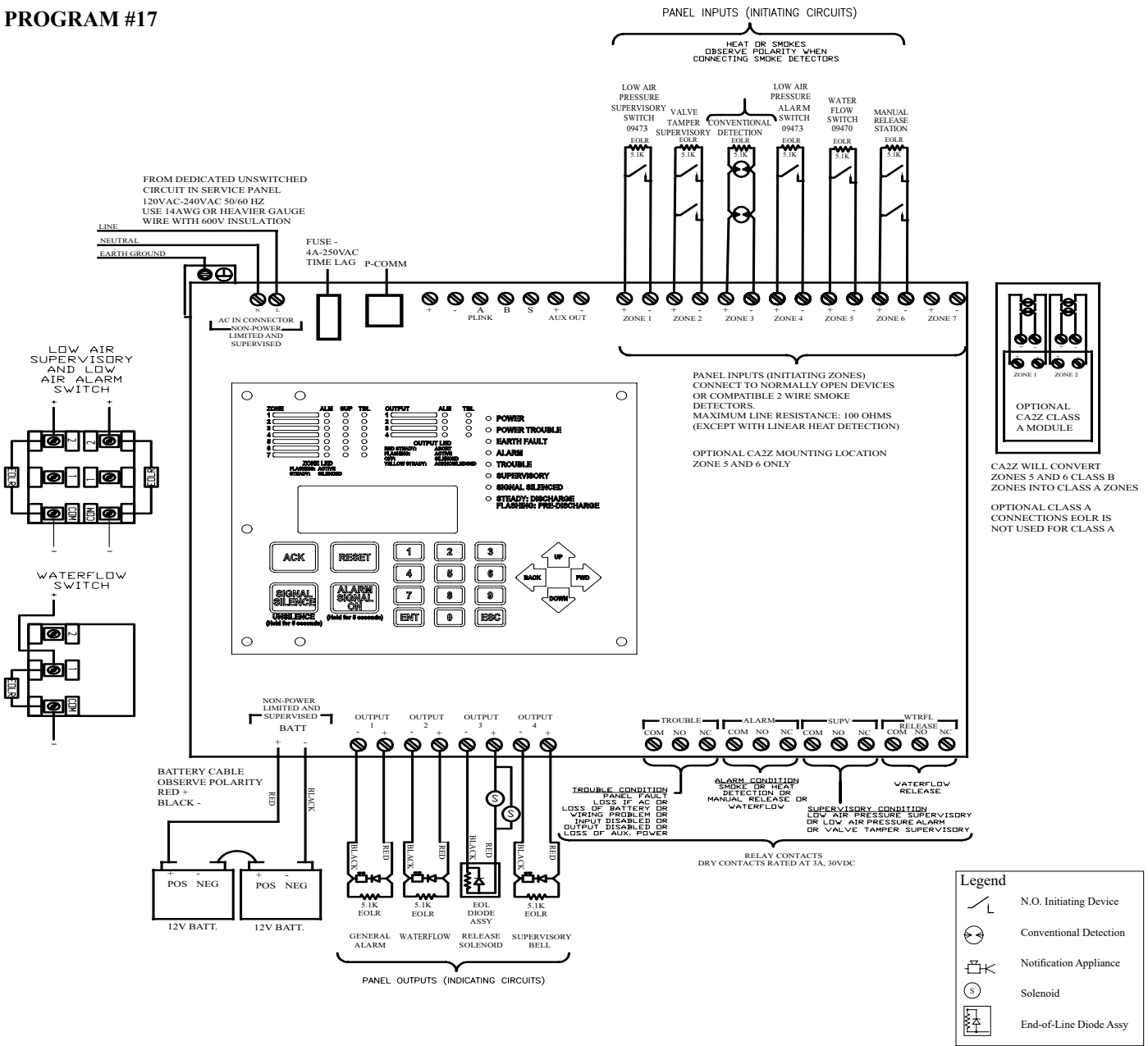

1. Run field wiring and ensure connections are proper by metering wires. Resistance reading should be 5.1K ohms with end-offline resistor (EOLR) at last device. The end-of-line resistor are supplied with the panel Install EOLR on all unused circuits.
2. Connect one circuit at a time and apply AC power.
3. Connect batteries to the panel
4. Press ENT to enter PROGRAM mode
5. Press 6 or scroll down to #6 and press ENT, (The selection is indicated by a flashing arrow next to the number.
6. Enter the password. (Factory default is 1111)
7. Press 1 or press ENT. (1 should be the highlighted selection)
8. The display shows the current program number. Press 17 to change to program 17. Press ENT.
9. Press 1 to accept the change.
10. Press ENT to accept the change

Note: Release solenoids #1 and #2 shall be wired in parallel and connected to output #3. the wiring shall be in conduit or otherwise protected. Any connections shall be made in a junction box. This may not conform to the monitoring for integrity requirements for NFPA 72.

| PROGRAM #17   |   |   |                             |                    |                |                     |        |                   |
|---|---|---|-----------------------------|--------------------|----------------|---------------------|--------|-------------------|
| For One Sprinkler System  |   |   |                             |                    |                |                     |        |                   |
| Viking Sprinkler System Types (UK Only)   | 2 Cross Release zones, Waterflow zone, and Manual Release zone  | 1. Double Interlocked Preaction System with Electric/Pneu-Lectric Release |                             |                    |                |                     |        |                   |
| OUTPUTS<br>(Indicating Circuits)  | ZONES (Initiating Circuits)   |   |                             |                    |                |                     |        | Software Zone     |
|   | #1  | #2  | #3                          | #4                 | #5             | #6                  | #7     | #8                |
|   | Low Air Supervisory Zone  | Valve Tamper Supervisory Zone   | Conventional Detection Zone | Low Air Alarm Zone | Waterflow Zone | Manual Release Zone | Unused | Release Type Zone |
| #1 General Alarm  |   |   | X                           |                    |                | X                   |        | X                 |
| #2 Waterflow Alarm  |   |   |                             |                    | X              |                     |        |                   |
| #3 Release Solenoid   |   |   | X X                         | X X                |                | X                   |        | XX*               |
| #4 Supervisory Bell   | X   | X   |                             | X                  |                |                     |        |                   |
| OPERATION DESCRIPTION   |   |   |                             |                    |                |                     |        |                   |
| Inputs:   | 1 Conventional Detection zone cross zoned with 1 Low Air Alarm zone, 1 Waterflow zone, 1 Manual Release zone, 2 Supervisory zones   |   |                             |                    |                |                     |        |                   |
| Outputs:  | 1 General Alarm, 1 Waterflow, 1 Release Solenoid, 1 Supervisory Bell  |   |                             |                    |                |                     |        |                   |
| Operation:  | Simultaneous activation of both the Conventional Detection zone 3 and the Low Air Alarm zone #4 will activate output #3 (Release solenoid), output #1 (General alarm), and output #4 (Supervisory Bell) |   |                             |                    |                |                     |        |                   |
|   | Activation of Conventional Detection zone #3 will activate output #1 (General Alarm)  |   |                             |                    |                |                     |        |                   |
|   | Activation of Low Air Alarm zone #4 will activate output #4 (Supervisory Bell)  |   |                             |                    |                |                     |        |                   |
|   | Activation of Waterflow zone #5 will activate output #2 (Waterflow)   |   |                             |                    |                |                     |        |                   |
|   | Activation of Manual Release zone #6 will activate output #3 (Release Solenoid) and output #1 (General Alarm)   |   |                             |                    |                |                     |        |                   |
| Activation of Low Air Supervisory zone #1 or Valve Tamper Supervisory zone #2 will operate output #4 (Supervisory Bell) |   |   |                             |                    |                |                     |        |                   |

\* Release Outputs which are Cross-Zoned need a Software Zone in order to work properly. The Software Zone Number will be displayed upon a release.

XX = Cross-Zoned

**NOTES:**

1. Connect EOL Diode assembly IN SERIES as shown with solenoids on outputs #3. Black wire to negative terminal on panel Red wire through solenoid to positive terminal on panel. Output #3 has 2 solenoids. These must be connected in parallel and the EOL diode is connected in series with the parallel solenoids.
2. Polarity is shown on indicating circuits in an activated (in alarm) condition.
3. Install EOLR (provided) on all unused circuits.
4. See the instruction manual for circuit information, panel limits, and battery sizing.
5. For wire routing instructions through the releasing panel, see Fig 1 on page 2-7 of the instruction manual.
6. See instruction manual for proper programming.
7. See instruction manual for list of compatible smoke detectors.
8. See specific system type data page for proper pressure switch settings.
9. For UL864 Approved Programming Options, see page 6-102.

**PROGRAM #18**

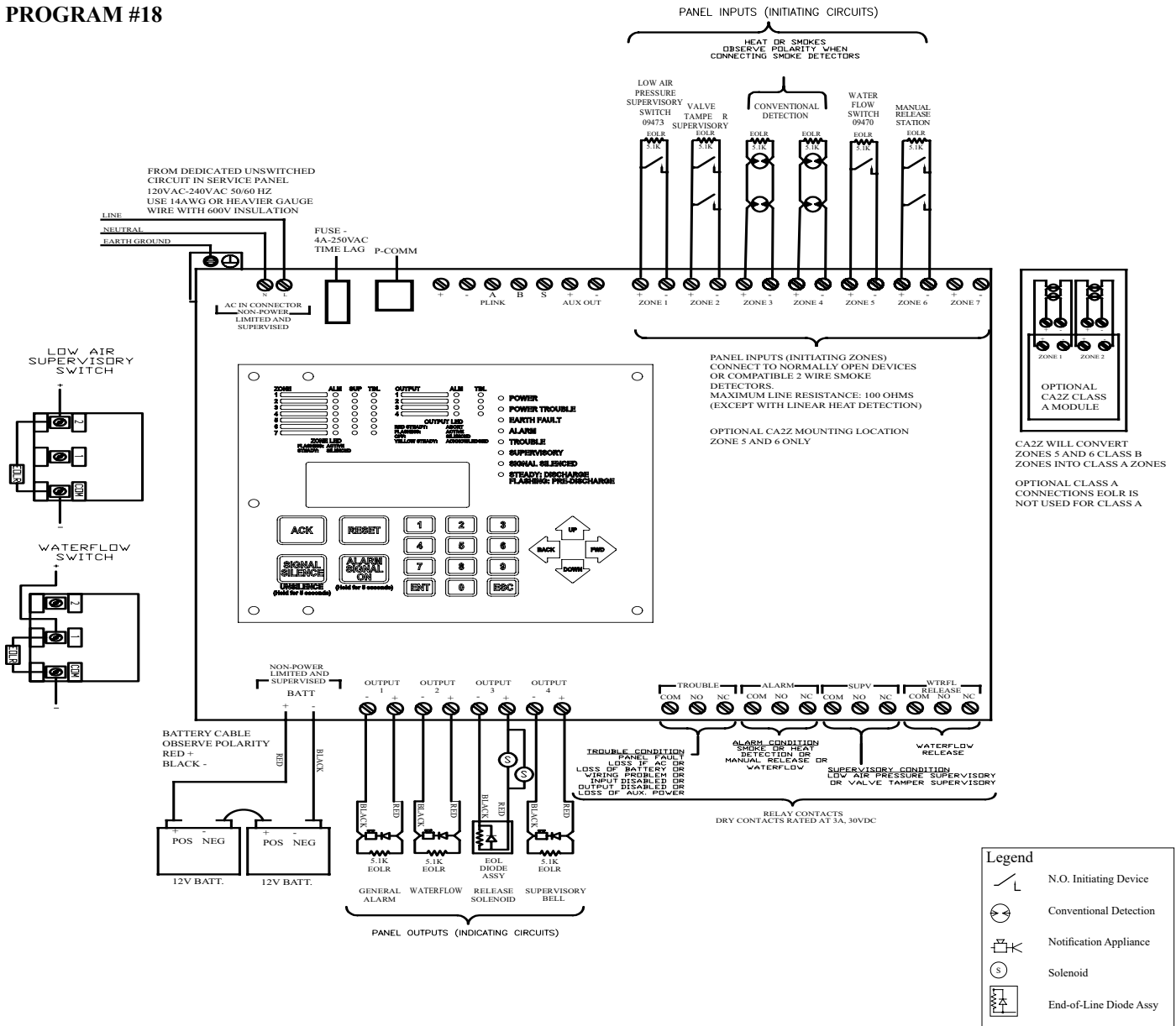

**NOTES:**

1. Run field wiring and ensure connections are proper by metering wires. Resistance reading should be 5.1K ohms with end-offline resistor (EOLR) at last device. The end-of-line resistor are supplied with the panel Install EOLR on all unused circuits.
2. Connect one circuit at a time and apply AC power.
3. Connect batteries to the panel
4. Press ENT to enter PROGRAM mode
5. Press 6 or scroll down to #6 and press ENT, (The selection is indicated by a flashing arrow next to the number.
6. Enter the password. (Factory default is 1111)
7. Press 1 or press ENT. (1 should be the highlighted selection)
8. The display shows the current program number. Press 18 to change to program 18. Press ENT.
9. Press 1 to accept the change.
10. Press ENT to accept the change

Note: Release solenoids #1 and #2 shall be wired in parallel and connected to output #3. the wiring shall be in conduit or otherwise protected. Any connections shall be made in a junction box. This may not conform to the monitoring for integrity requirements for NFPA 72.



| PROGRAM #18                             |   |  |                             |                             |                |                     |        |
|---|---|--|-----------------------------|-----------------------------|----------------|---------------------|--------|
| For One Sprinkler System                |   |  |                             |                             |                |                     |        |
| Viking Sprinkler System Types (UK Only) | 2 Release Zones, Waterflow Zone, & Manual Release Zone  | 1. Single Interlocked Preaction System with Electric Release           |                             |                             |                |                     |        |
|   |   | 2. Deluge System with Electric Release                                 |                             |                             |                |                     |        |
|   |   | 3. Non-Interlocked Preaction System with Electric Release              |                             |                             |                |                     |        |
|   |   | 4. Double Interlocked Preaction System with Electric/Pneumatic Release |                             |                             |                |                     |        |
| OUTPUTS (Indicating Circuits)           | ZONES (Initiating Circuits)   |  |                             |                             |                |                     |        |
|   | #1  | #2   | #3                          | #4                          | #5             | #6                  | #7     |
|   | Low Air Supervisory Zone  | Valve Tamper Supervisory Zone  | Conventional Detection Zone | Conventional Detection Zone | Waterflow Zone | Manual Release Zone | Unused |
| #1 General Alarm                        |   |  | X                           | X                           | X              | X                   |        |
| #2 Waterflow                            |   |  |                             |                             | X              |                     |        |
| #3 Release Solenoid                     |   |  | X                           | X                           |                | X                   |        |
| #4 Supervisory Bell                     | X   | X  |                             |                             |                |                     |        |
| OPERATION DESCRIPTION                   |   |  |                             |                             |                |                     |        |
| Inputs:                                 | 2 Conventional Detection zones, 1 Waterflow zone, 1 Manual Release zone, 2 Supervisory zones  |  |                             |                             |                |                     |        |
| Outputs:                                | 1 General Alarm, 1 Waterflow Alarm, 1 Solenoid Release, 1 Supervisory Bell  |  |                             |                             |                |                     |        |
| Operation:                              | Activation of Conventional Detection zone #3 or #4 or Manual Release zone #6 will activate output #3 (Release Solenoid) and output #1 (General Alarm) |  |                             |                             |                |                     |        |
|   | Activation of Waterflow zone #5 will activate output #2 (Waterflow) and output #1 (General Alarm)   |  |                             |                             |                |                     |        |
|   | Activation of Low Air Supervisory zone #1 or Valve Tamper Supervisory zone #2 will operate output #4 (Supervisory Bell).                              |  |                             |                             |                |                     |        |

**NOTES:**

1. Connect EOL Diode assembly IN SERIES as shown with solenoids on outputs #3. Black wire to negative terminal on panel. Red wire through solenoid to positive terminal on panel. Output #3 has 2 solenoids. These must be connected in parallel and the EOL diode is connected in series with the parallel solenoids..
2. Polarity is shown on indicating circuits in an activated (in alarm) condition.
3. Install EOLR (provided) on all unused circuits.
4. See the instruction manual for circuit information, panel limits, and battery sizing.
5. For wire routing instructions through the releasing panel, see Fig 1 on page 2-7 of the instruction manual.
6. See instruction manual for proper programming.
7. See instruction manual for list of compatible smoke detectors.
8. See specific system type data page for proper pressure switch settings.
9. For UL864 Approved Programming Options, see page 6-102.

PROGRAM #19

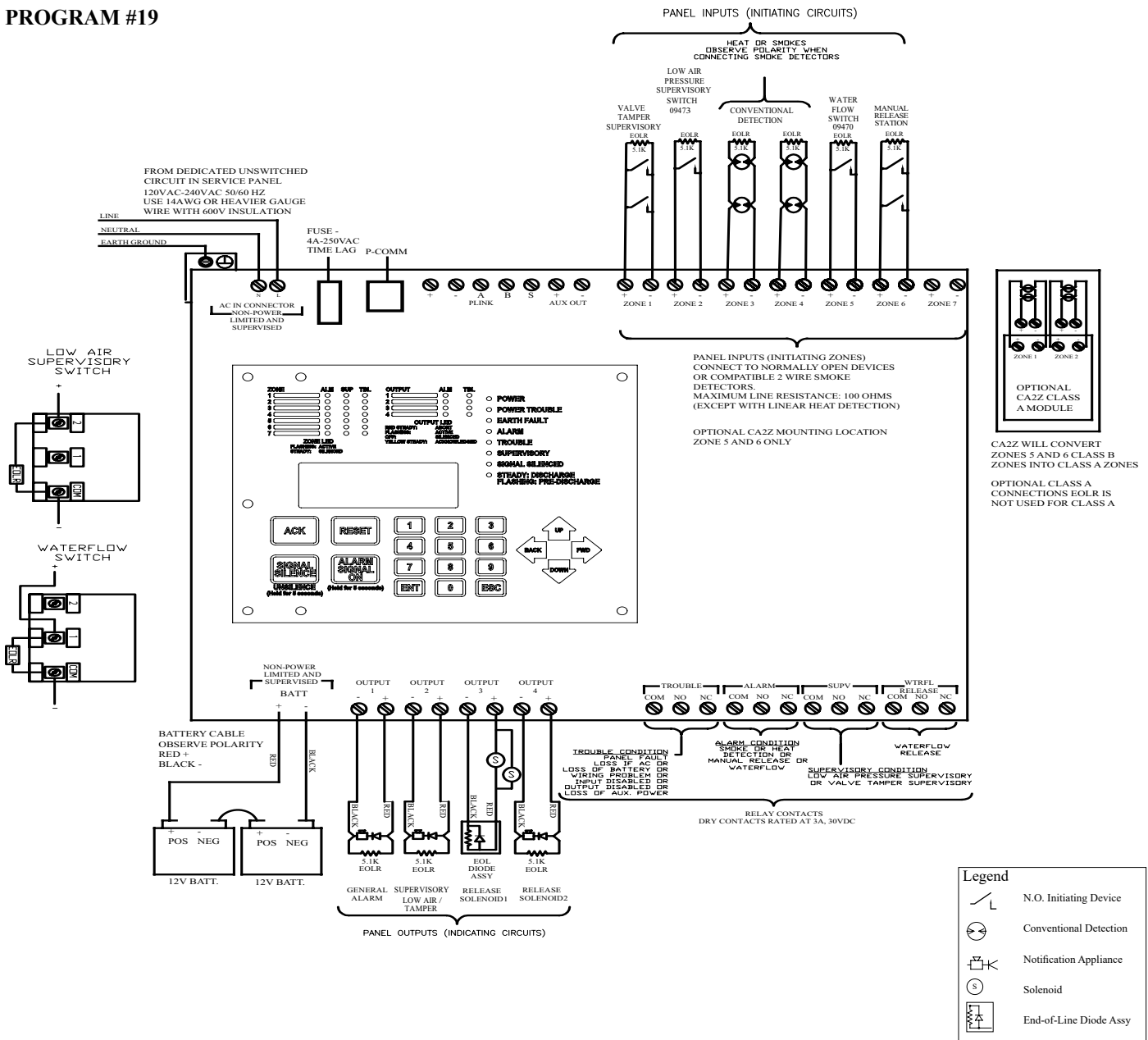

1. Run field wiring and ensure connections are proper by metering wires. Resistance reading should be 5.1K ohms with end-of-line resistor. The end-of-line resistor are supplied with the panel. Install EOLR on all unused circuits.
2. Connect one circuit at a time and apply AC power.
3. Connect batteries to the panel
4. Press ENT to enter PROGRAM mode
5. Press 6 or scroll down to #6 and press ENT, (The selection is indicated by a flashing arrow next to the number.
6. Enter the password. (Factory default is 1111)
7. Press 1 or press ENT. (1 should be the highlighted selection)
8. The display shows the current program number. Press 19 to change to program 19. Press ENT.
9. Press 1 to accept the change.
10. Press ENT to accept the change

Note: Release solenoids #1 and #2 shall be wired in parallel and connected to output #3. the wiring shall be in conduit otherwise protected. Any connections shall be made in a junction box. This may not conform to the monitoring for integrity requirements for NFPA 72.

| PROGRAM #19                             |  |  |                             |                             |                |                     |        |                   |
|---|--|--|-----------------------------|-----------------------------|----------------|---------------------|--------|-------------------|
| For One Sprinkler System                |  |  |                             |                             |                |                     |        |                   |
| Viking Sprinkler System Types (UK Only) | 2 Cross Release Zones, Waterflow Zone, & Manual Release Zone   | 1. Single Interlocked Preaction System with Electric Release           |                             |                             |                |                     |        |                   |
|   |  | 2. Deluge System with Electric Release                                 |                             |                             |                |                     |        |                   |
|   |  | 3. Non-Interlocked Preaction System with Electric Release              |                             |                             |                |                     |        |                   |
|   |  | 4. Double Interlocked Preaction System with Electric/Pneumatic Release |                             |                             |                |                     |        |                   |
| OUTPUTS (Indicating Circuits)           | ZONES (Initiating Circuits)  |  |                             |                             |                |                     |        | Software Zone     |
|   | #1   | #2   | #3                          | #4                          | #5             | #6                  | #7     | #8                |
|   | Valve Tamper Supervisory Zone  | Low Air Supervisory Zone   | Conventional Detection Zone | Conventional Detection Zone | Waterflow Zone | Manual Release Zone | Unused | Release Type Zone |
| #1 General Alarm                        |  |  | X                           | X                           |                | X                   |        | X                 |
| #2 Waterflow                            |  |  |                             |                             | X              |                     |        |                   |
| #3 Release Solenoid                     |  |  | XX                          | XX                          |                | X                   |        | XX*               |
| #4 Supervisory Bell                     | X  | X  |                             |                             |                |                     |        |                   |
| OPERATION DESCRIPTION                   |  |  |                             |                             |                |                     |        |                   |
| Inputs:                                 | 2 Conventional Detection zones, 1 Waterflow zone, 1 Manual Release zone, 2 Supervisory zones   |  |                             |                             |                |                     |        |                   |
| Outputs:                                | 1 General Alarm, 1 Waterflow Alarm, 1 Solenoid Release, 1 Supervisory Bell   |  |                             |                             |                |                     |        |                   |
| Operation:                              | Activation of Conventional Detection zone #3 and #4 or Manual Release zone #6 will activate output #3 (Release Solenoid) and output #1 (General Alarm) |  |                             |                             |                |                     |        |                   |
|   | Activation of Waterflow zone #5 will activate output #2 (Waterflow)  |  |                             |                             |                |                     |        |                   |
|   | Activation of Low Air Supervisory zone #1 or Valve Tamper Supervisory zone #2 will operate output #4 (Supervisory Bell).                               |  |                             |                             |                |                     |        |                   |

\* Release Outputs which are Cross-Zoned need a Software Zone in order to work properly. The Software Zone Number will be displayed upon a release.

XX = Cross-Zoned

**NOTES:**

1. Connect EOL Diode assembly IN SERIES as shown with solenoids on outputs #3. Black wire to negative terminal on panel. Red wire through solenoid to positive terminal on panel. Output #3 has 2 solenoids. These must be connected in parallel and the EOL diode is connected in series with the parallel solenoids.
2. Polarity is shown on indicating circuits in an activated (in alarm) condition.
3. Install EOLR (provided) on all unused circuits.
4. See the instruction manual for circuit information, panel limits, and battery sizing.
5. For wire routing instructions through the releasing panel, see Fig 1 on page 2-7 of the instruction manual.
6. See instruction manual for proper programming.
7. See instruction manual for list of compatible smoke detectors.
8. See specific system type data page for proper pressure switch settings.
9. For UL864 Approved Programming Options, see page 6-102.

**NOTICE**

The following programs are for agent or gas extinguishing systems. Selecting the Agent Release mode allows the use of a pre-discharge timer and an abort circuit. The timer defaults to 60 seconds for all alarm zones programmed as other than MANUAL RELEASE. The MANUAL RELEASE default timer is 30 seconds. The system offers the programmer the ability to change the default timers to shorter times.

Systems intended for the release of Halon 1301 as described in NFPA 12A, water mist systems as described in NFPA 750 clean agents as described in NFPA 2001, or fixed aerosol as described in NFPA 2010, or shall have provision for a pre-discharge notification circuit. If this signal is required to be separate and/or distinct from the evacuation signal, this can be accomplished by using the legacy method of using first and second alarms on separate zones. One shall be programmed as FIRST ALARM. It will provide a steady output upon activation of any initiating zone programmed as an alarm zone. This is the evacuation signal. If a temporal signal is required, the output pattern can be changed using the zone menu. The other notification circuit shall be programmed as SECOND ALARM. It will provide a steady output upon activation of a second initiating zone programmed as an alarm zone (cross zoned). This is when the pre-discharge timer would start and would be the pre-discharge signal. If a temporal signal is required, the output pattern can be changed using the zone menu (output pattern and pre release pattern need to be changed). If a separate signal for discharge were required, the second alarm pre discharge pattern can be changed in the zone menu. Zones programmed as MANUAL RELEASE will activate outputs programmed as SECOND ALARM, even if the MANUAL RELEASE zone is the first alarm zone activated. SECOND ALARM is intended to be used as a pre-discharge signal for cross zone applications.

The VFR-500 allow for 3 patterns using 1 notification circuit. The evacuation signal pattern can be set in the zone menu for the detection zones mapped to the alarm indicating output. To set the pre discharge pattern and discharge pattern select the pattern in the zone menu for the software zone for the cross zoned output.

**CAUTION**

**The default programming does not allow the abort circuit to abort the release or stop the pre-discharge timer activated by zones programmed as MANUAL RELEASE. This can be changed in the programming to allow MANUAL RELEASE zones to be aborted.**

NFPA 12 prohibits the use of abort circuits on suppression systems deploying carbon dioxide.

Systems designed and installed in accordance with NFPA 2001, NFPA-750, NFPA-2010, NFPA 12 A shall be provided with a mechanical manual release system.

**This page intentionally left blank.**

Wiring Diagram Program #20

Dual Hazard, 2 Detection Zones Cross-Zoned to 1 Release Circuit, 2  
 Other Detection Zones Cross-Zoned to A Separate Release Circuit, 1  
 Supervisory Zone, 1 Abort Circuit

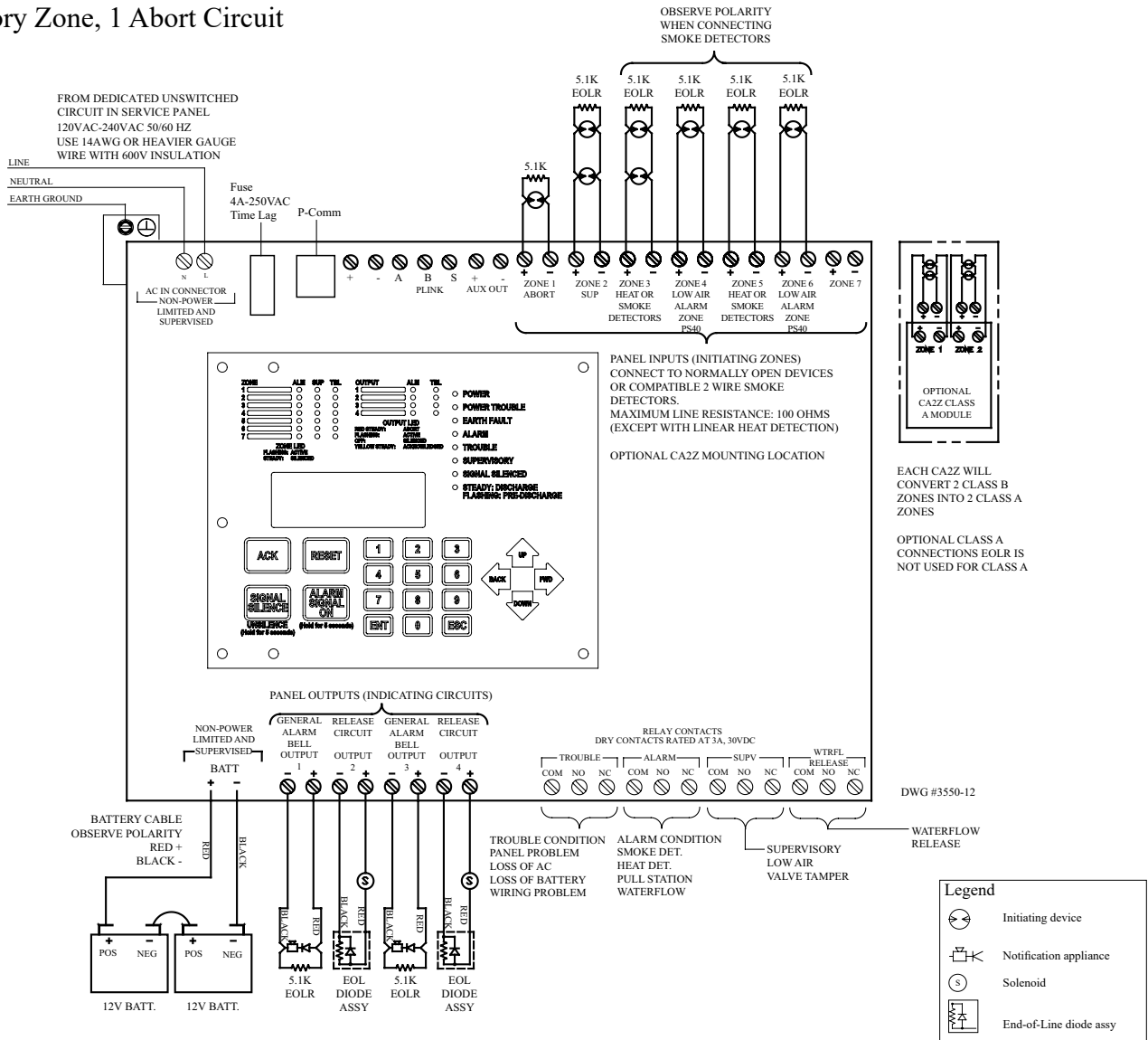

NOTES:

1. Connect only UL Listed 24VDC devices to indicating circuits.
2. Connect EOL Diode assembly IN SERIES with solenoid on release circuit
3. Install EOLR (provided) on all unused circuits.
4. Polarity is shown on indicating circuits in an activated (off-normal) condition.
5. Polarity reverses when output is activated.
6. Maximum current per output is 3 Amp. Maximum voltage is 33VDC.
7. Outputs identified as Release are Special Application. All other outputs are Regulated 24 VDC, Rated 3 Amp each, 3 Amp total for all 4 circuits.
8. All initiating and NAC/Release circuits are supervised and power limited. See Main Board Wiring Specifications for wire routing instructions. All frequencies are continuous.
9. Refer to Appendix A for test and maintenance information

10. Maximum resistance on outputs is 10 ohms. Maximum resistance on outputs programmed as releasing, is 1 divided by current requirements of solenoid.

See Appendix C for smoke detector compatibility data.

See Battery Calculation Worksheet for battery information.

**Program #20 Mode**

1. Apply power to panel.
2. Press ENT to enter PROGRAM mode
3. Press 6 or scroll down to #6 and press ENT, (The selection is indicated by a flashing arrow next to the number.
4. Enter the password. (Factory default is 1111)
5. Press 1 or press ENT. (1 should be the highlighted selection)
6. The display shows the current program number. Press 20 to change to program 20. Press ENT.
7. Press 1 to accept the change.
8. Press ENT to accept the change.

| Dual Hazard, 2 Detection Zones Cross-Zoned to 1 Release Circuit, 2 Other Detection Zones Cross-Zoned to a Separate Release Circuit, 1 Supervisory Circuit, 1 abort circuit | PROGRAM #20              |             |           |           |           |           |        |                   |                   |
|--|--------------------------|-------------|-----------|-----------|-----------|-----------|--------|-------------------|-------------------|
|  | CONVENTIONAL INPUT ZONES |             |           |           |           |           |        | SOFTWARE ZONES    |                   |
|  | #1                       | #2          | #3        | #4        | #5        | #6        | #7     | #8                | #9                |
| OUTPUTS  | Abort                    | Supervisory | Detection | Detection | Detection | Detection | Unused | Release Zone Type | Release Zone Type |
| #1 ALARM INDICATING  |                          |             | X         | X         |           |           |        | X                 |                   |
| #2 RELEASE   |                          |             | XX        | XX        |           |           |        | XX*               |                   |
| #3 ALARM INDICATING  |                          |             |           |           | X         | X         |        |                   | X                 |
| #4 RELEASE   |                          |             |           |           | XX        | XX        |        |                   | XX*               |

\* Release Outputs which are Cross-Zoned need a Software Zone in order to work properly. The Software Zone Number will be displayed upon a release.

XX = Cross-Zoned

Description: Dual Hazard, 2 detection zones cross-zoned to 1 release circuit and 2 other detection zones cross zoned to another release circuit

Inputs: 1 supervisory zone, 4 detection zones, 1 abort circuit

Outputs: 2 general alarm, 2 release circuit

Operation: Activation of either detection zones 3 or 4 will activate the alarm output #1  
 Activation of both detection circuits 3 and 4 at the same time will start the pre-discharge timer for release circuit output #2 as well as activate the alarm output #1  
 Activation of either detection zones 5 or 6 will activate the alarm output #3  
 Activation of both detection circuits 5 and 6 at the same time will start the pre-discharge timer for release circuit output #4 as well as activate the alarm output #3

When either zone 3 or 4 is in alarm, output 1 will operate  
 When both zones 3 and 4 are in alarm at the same time, the pre-discharge timer for output #2 will operate  
 When either zone 5 or 6 is in alarm, output 3 will operate  
 When both zones 5 and 6 are in alarm at the same time, the pre-discharge timer for output #4 will operate

Wiring Diagram Program #21

Dual Hazard, 2 Detection Zones Mapped to 1 Release Circuit and 2 Other Detection Zones Mapped to A Separate Circuit, 1 Abort Circuit, and 1 Supervisory Circuit

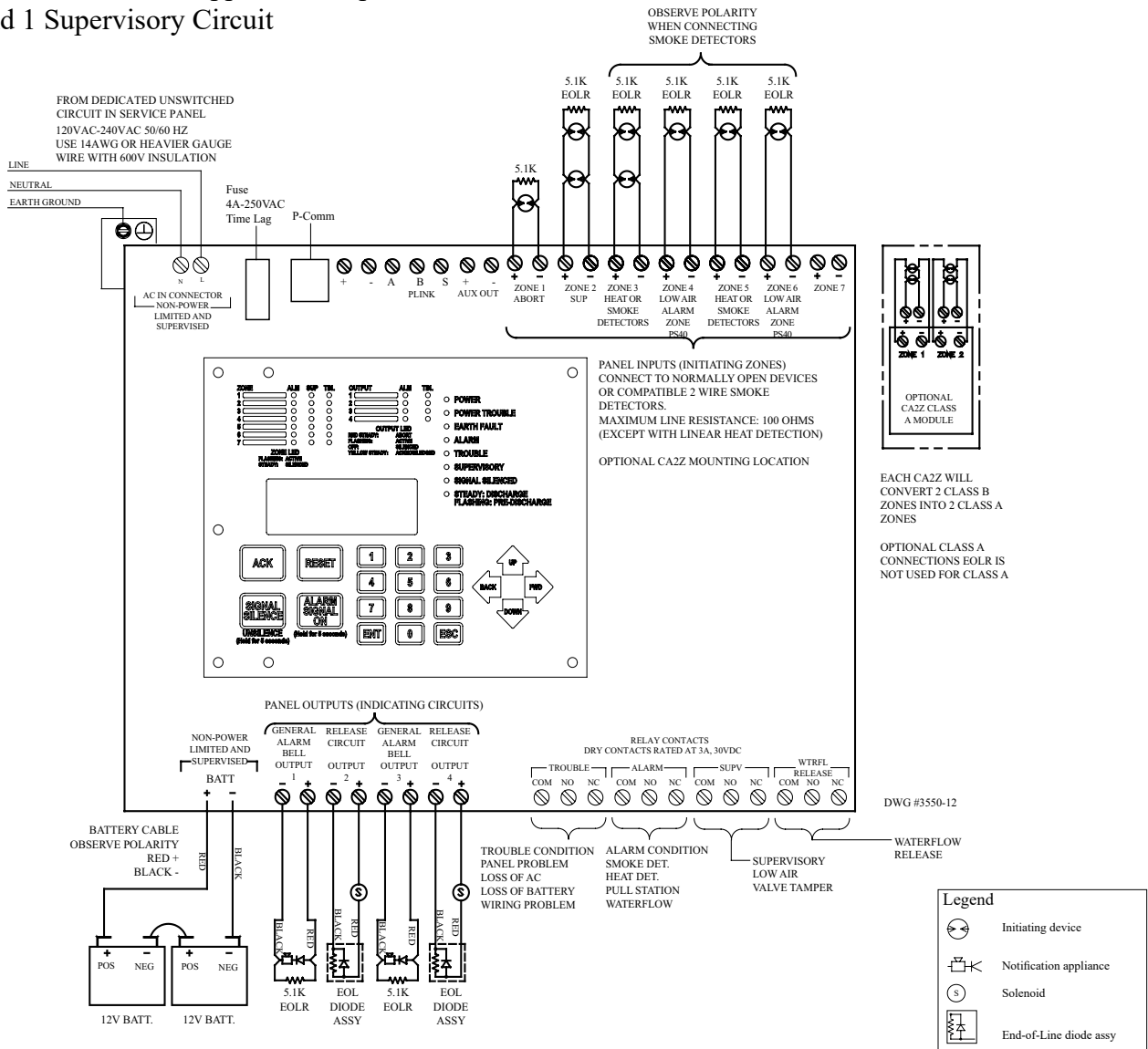

NOTES:

1. Connect only UL Listed 24VDC devices to indicating circuits.
2. Connect EOL Diode assembly IN SERIES with solenoid on release circuit
3. Install EOLR (provided) on all unused circuits.
4. Polarity is shown on indicating circuits in an activated (off-normal) condition.
5. Polarity reverses when output is activated.
6. Maximum current per output is 3 Amp. Maximum voltage is 33VDC.
7. Outputs identified as Release are Special Application. All other outputs are Regulated 24 VDC, Rated 3 Amp each, 3 Amp total for all 4 circuits.
8. All initiating and NAC/Release circuits are supervised and power limited. See Main Board Wiring Specifications for wire routing instructions. All frequencies are continuous.
9. Refer to Appendix A for test and maintenance information

10. Maximum resistance on outputs is 10 ohms. Maximum resistance on outputs programmed as releasing, is 1 divided by current requirements of solenoid.

See Appendix C for smoke detector compatibility data.

See Battery Calculation Worksheet for battery information.



**Program #21 Mode**

1. Apply power to panel.
2. Press ENT to enter PROGRAM mode
3. Press 6 or scroll down to #6 and press ENT, (The selection is indicated by a flashing arrow next to the number.
4. Enter the password. (Factory default is 1111)
5. Press 1 or press ENT. (1 should be the highlighted selection)
6. The display shows the current program number. Press 21 to change to program 21. Press ENT.
7. Press 1 to accept the change.
8. Press ENT to accept the change.

| Dual Hazard, 2 Detection Zones Mapped to 1 Release Circuit and 2 Other Detection Zones Mapped to a Separate Release Circuit, 1 Supervisory Circuit, 1 Abort Circuit | PROGRAM #21              |             |           |           |           |           |        |
|---|--------------------------|-------------|-----------|-----------|-----------|-----------|--------|
|   | CONVENTIONAL INPUT ZONES |             |           |           |           |           |        |
|   | #1                       | #2          | #3        | #4        | #5        | #6        | #7     |
| OUTPUTS   | Abort                    | Supervisory | Detection | Detection | Detection | Detection | Unused |
| #1 ALARM INDICATING   |                          |             | X         | X         |           |           |        |
| #2 RELEASE  |                          |             | X         | X         |           |           |        |
| #3 ALARM INDICATING   |                          |             |           |           | X         | X         |        |
| #4 RELEASE  |                          |             |           |           | X         | X         |        |

Description: Dual Hazard, 2 detection zones mapped to 1 release circuit and 2 other detection zones mapped to another release circuit

Inputs: 1 supervisory zone, 4 detection zones, 1 abort circuit

Outputs: 2 general alarm, 2 release circuit

Operation: Activation of either detection zone 3 or 4 will activate the alarm output #1 and start the pre-discharge timer for the release circuit output #2  
 Activation of either detection zone 5 or 6 will activate the alarm output #3 and start the pre-discharge timer for the release circuit output #2

When either zone 3 or 4 is in alarm, outputs 1 & 2 will operate  
 When either zone 5 or 6 is in alarm, outputs 3 & 4 will operate

Wiring Diagram Program #22  
 Single Hazard, 2 Detection Zones Cross-zoned to  
 1 Release Circuit, 1 Manual Station and A Discharge  
 Confirmation Zone

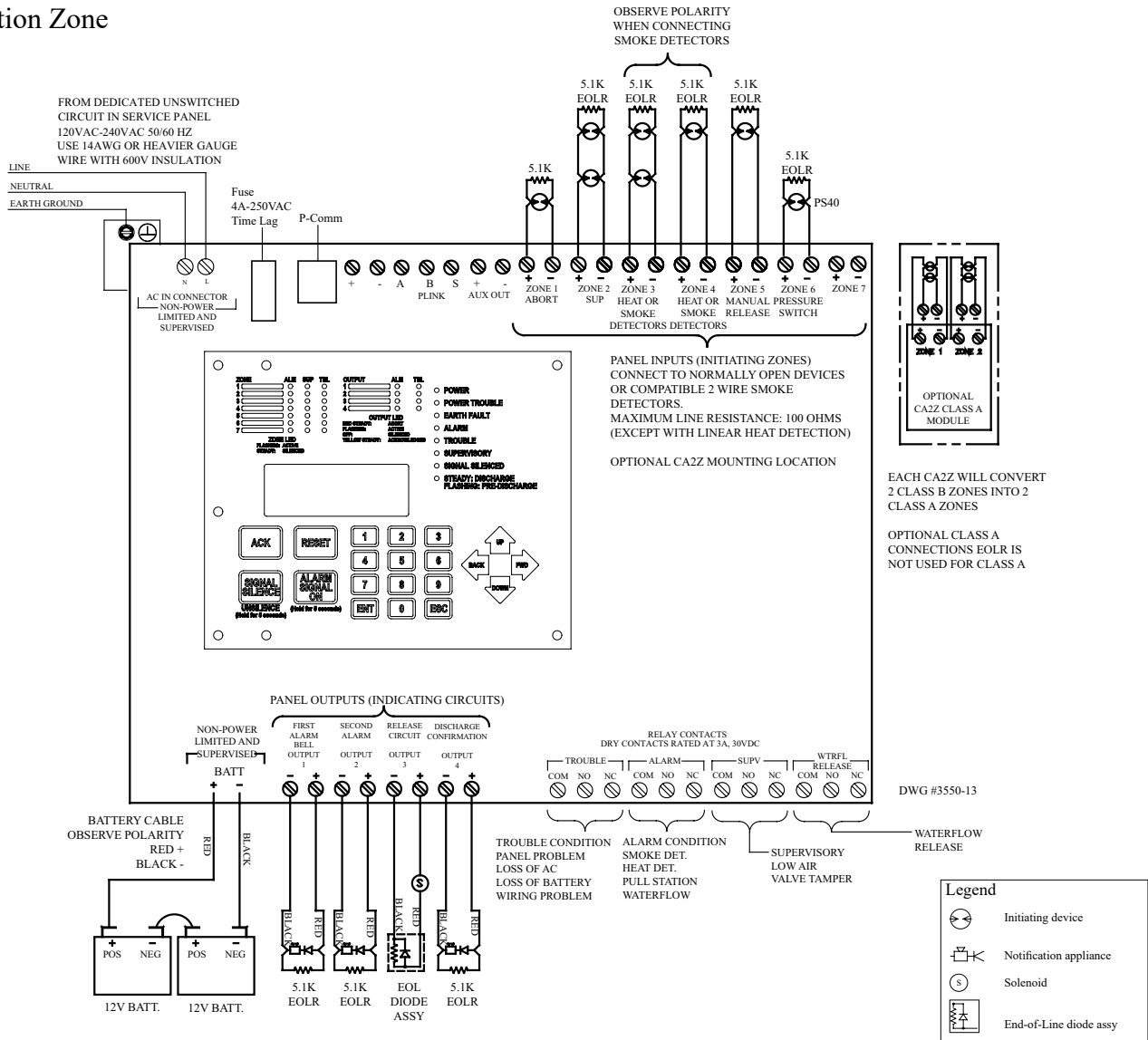

NOTES:

1. Connect only UL Listed 24VDC devices to indicating circuits.
2. Connect EOL Diode assembly IN SERIES with solenoid on release circuit
3. Install EOLR (provided) on all unused circuits.
4. Polarity is shown on indicating circuits in an activated (off-normal) condition.
5. Polarity reverses when output is activated.
6. Maximum current per output is 3 Amp. Maximum voltage is 33VDC.
7. Outputs identified as Release are Special Application. All other outputs are Regulated 24 VDC, Rated 3 Amp each, 3 Amp total for all 4 circuits.
8. All initiating and NAC/Release circuits are supervised and power limited. See Main Board Wiring Specifications for wire routing instructions. All frequencies are continuous.
9. Refer to Appendix A for test and maintenance information

10. Maximum resistance on outputs is 10 ohms. Maximum resistance on outputs programmed as releasing, is 1 divided by current requirements of solenoid.

See Appendix C for smoke detector compatibility data.

See Battery Calculation Worksheet for battery information.

**Program #22 Mode**

1. Apply power to panel.
2. Press ENT to enter PROGRAM mode
3. Press 6 or scroll down to #6 and press ENT, (The selection is indicated by a flashing arrow next to the number.
4. Enter the password. (Factory default is 1111)
5. Press 1 or press ENT. (1 should be the highlighted selection)
6. The display shows the current program number. Press 22 to change to program 22. Press ENT.
7. Press 1 to accept the change.
8. Press ENT to accept the change.

| Single Hazard, 2 Detection Zones Cross-Zoned to 1 Release Circuit, 1 Manual Station and a Discharge Confirmation Zone | PROGRAM #22              |             |           |           |                |           |        |                |                   |
|---|--------------------------|-------------|-----------|-----------|----------------|-----------|--------|----------------|-------------------|
|   | CONVENTIONAL INPUT ZONES |             |           |           |                |           |        | Software Zones |                   |
|   | #1                       | #2          | #3        | #4        | #5             | #6        | #7     | #8             | #9                |
| OUTPUTS   | Abort                    | Supervisory | Detection | Detection | Manual Release | Detection | Unused | Alarm          | Release Zone Type |
| #1 1st ALARM  |                          |             | X         | X         |                |           |        |                |                   |
| #2 2nd ALARM  |                          |             | XX        | XX        | X              |           |        | XX*            | X                 |
| #3 RELEASE  |                          |             | XX        | XX        | X              |           |        |                | XX*               |
| #4 ALARM INDICATING   |                          |             |           |           |                | X         |        |                |                   |

**\* Release Outputs which are Cross-Zoned and 2nd alarm need a Software Zone in order to work properly. The Software Zone Number will be displayed upon a release.**

XX = Cross-Zoned

**Description:** Single Hazard, 2 detection zones cross-zoned to 1 release circuit. A manual station zone and a discharge confirmation zone. Also first and second alarm notification circuits.

**Inputs:** 1 supervisory zone, 3 detection zones, 1 manual station zone, 1 abort circuit

**Outputs:** 3 general alarm, 1 release circuit

**Operation:** Activation of either detection zones 3 or 4 will activate the alarm output #1  
 Activation of both detection circuits 3 and 4 at the same time will activate the alarm outputs #1, #2 and start the pre-discharge timer for the release circuit output #3  
 Activation of the manual release zone #5 will activate the alarm output #2 and start the manual release pre-discharge timer for release circuit output #3  
 Activation of zone 6 will operate output #4

When either zone 3 or 4 is in alarm, output 1 will operate

When both zones 3 and 4 are in alarm at the same time, outputs #1,2 will operate and the pre-discharge timer for output #3 will start

When zone 5 is in alarm, output 2 will operate and the manual release pre-discharge timer for output #3 will start

When zone 6 is in alarm, output #4 will operate

Wiring Diagram Program #23  
 Single Hazard, 4 Detection Zones Mapped to 1 Release  
 Circuit, 1 Supervisory Zone, 1 Abort Circuit

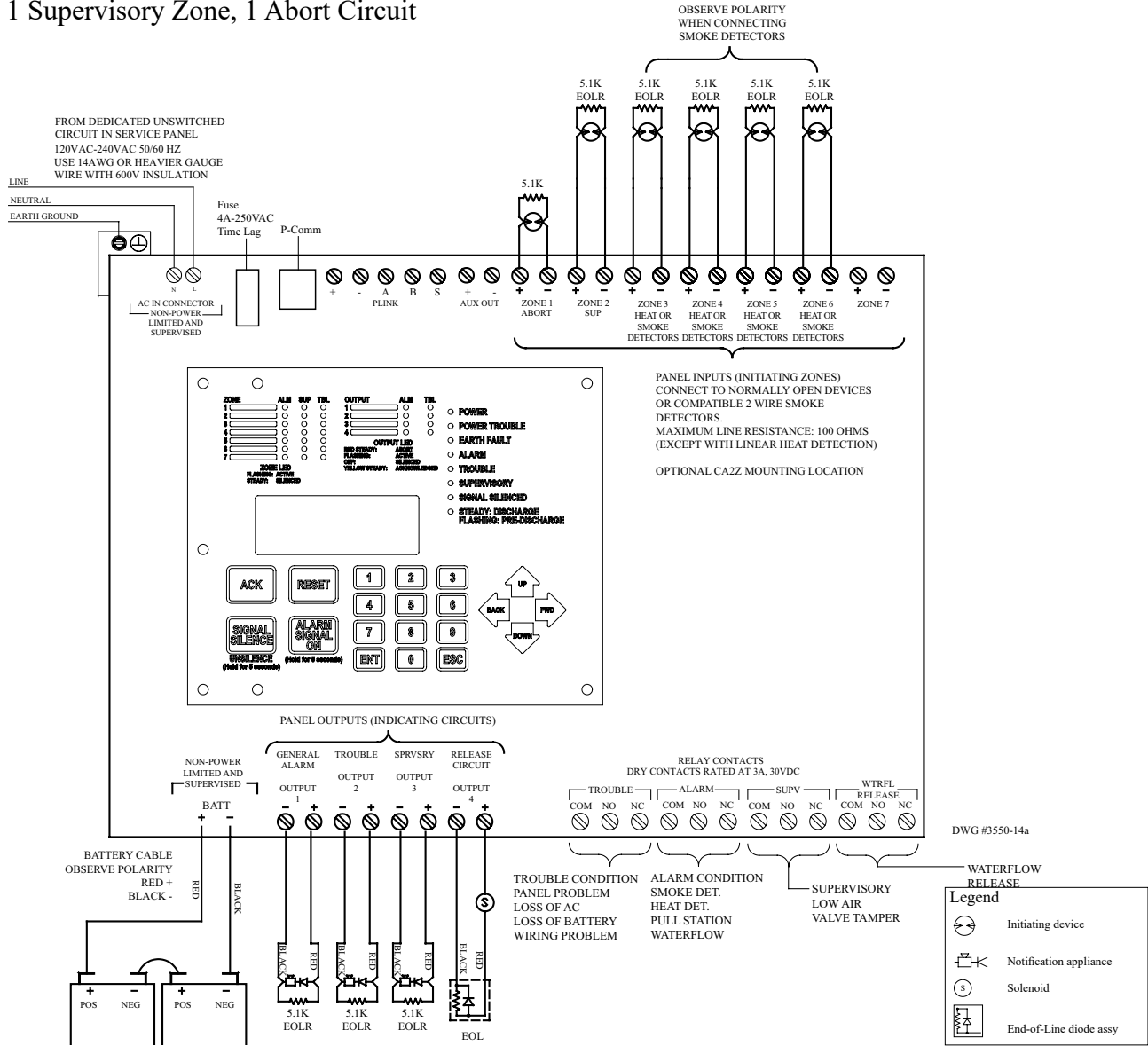

NOTES:

1. Connect only UL Listed 24VDC devices to indicating circuits.
2. Connect EOL Diode assembly IN SERIES with solenoid on release circuit
3. Install EOLR (provided) on all unused circuits.
4. Polarity is shown on indicating circuits in an activated (off-normal) condition.
5. Polarity reverses when output is activated.
6. Maximum current per output is 3 Amp. Maximum voltage is 33VDC.
7. Outputs identified as Release are Special Application. All other outputs are Regulated 24 VDC, Rated 3 Amp each, 3 Amp total for all 4 circuits.
8. All initiating and NAC/Release circuits are supervised and power limited. See Main Board Wiring Specifications for wire routing instructions. All frequencies are continuous.
9. Refer to Appendix A for test and maintenance information

10. Maximum resistance on outputs is 10 ohms. Maximum resistance on outputs programmed as releasing, is 1 divided by current requirements of solenoid.

See Appendix C for smoke detector compatibility data.

See Battery Calculation Worksheet for battery information.

**Program #23 Mode**

1. Apply power to panel.
2. Press ENT to enter PROGRAM mode
3. Press 6 or scroll down to #6 and press ENT, (The selection is indicated by a flashing arrow next to the number.
4. Enter the password. (Factory default is 1111)
5. Press 1 or press ENT. (1 should be the highlighted selection)
6. The display shows the current program number. Press 23 to change to program 23. Press ENT.
7. Press 1 to accept the change.
8. Press ENT to accept the change.

| Single Hazard, 4<br>Detection Zones Mapped<br>to 1 Release Circuit 1<br>Supervisory Circuit, 1<br>Abort Circuit | PROGRAM #23              |             |           |           |           |           |        |
|---|--------------------------|-------------|-----------|-----------|-----------|-----------|--------|
|   | CONVENTIONAL INPUT ZONES |             |           |           |           |           |        |
|   | #1                       | #2          | #3        | #4        | #5        | #6        | #7     |
| OUTPUTS   | Abort                    | Supervisory | Detection | Detection | Detection | Detection | Unused |
| #1 ALARM INDICATING   |                          |             | X         | X         | X         | X         |        |
| #2 TROUBLE  |                          |             |           |           |           |           |        |
| #3 SUPERVISORY  |                          | X           |           |           |           |           |        |
| #4 RELEASE  |                          |             | X         | X         | X         | X         |        |

Description: Single Hazard, 4 detection zones mapped to 1 release  
 Inputs: 1 supervisory zone, 4 detection zones, 1 abort circuit  
 Outputs: 1 general alarm, 1 trouble, 1 supervisory, 1 release circuit  
 Operation: Activation of any detection zone will activate the alarm output #1 and start the pre-discharge timer for the release circuit output #4.  
 Activation of the supervisory zone will operate the supervisory bell.  
 A trouble condition (low battery, wire problem, etc.) will operate the trouble bell.

When either zone 3, 4, 5, or 6 is in alarm, outputs 1 & 4 will operate  
 When the zone 6 supervisory zone is activated - output #3 (supervisory bell) will operate.  
 When the panel is in a trouble condition - output #2 (trouble bell) will operate.

Wiring Diagram Program #24  
 Single Hazard, 2 Detection Zones 1 Manual Station Zone  
 and A Discharge Confirmation Zone

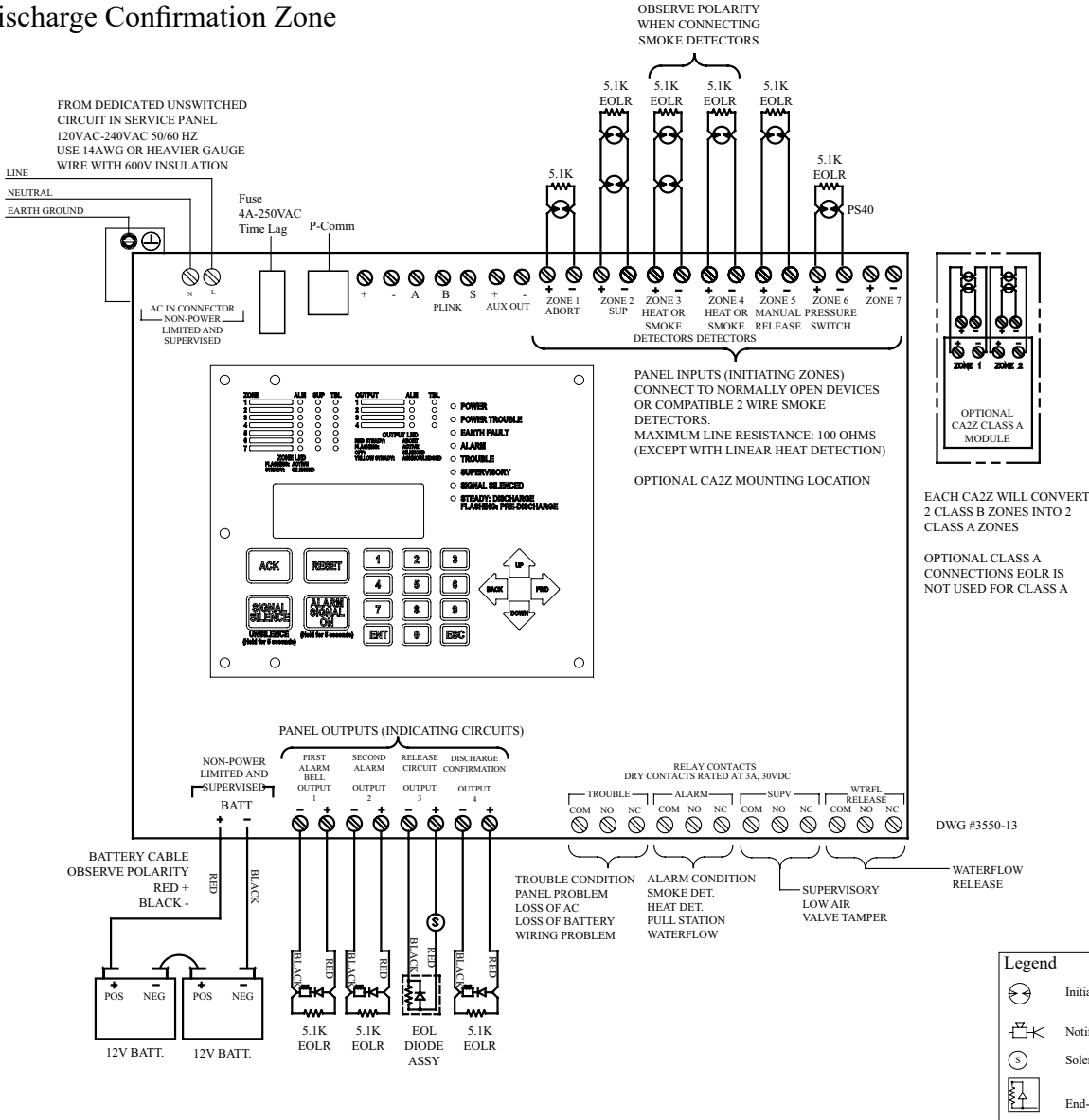

NOTES:

1. Connect only UL Listed 24VDC devices to indicating circuits.
2. Connect EOL Diode assembly IN SERIES with solenoid on release circuit
3. Install EOLR (provided) on all unused circuits.
4. Polarity is shown on indicating circuits in an activated (off-normal) condition.
5. Polarity reverses when output is activated.
6. Maximum current per output is 3 Amp. Maximum voltage is 33VDC.
7. Outputs identified as Release are Special Application. All other outputs are Regulated 24 VDC, Rated 3 Amp each, 3 Amp total for all 4 circuits.
8. All initiating and NAC/Release circuits are supervised and power limited. See Main Board Wiring Specifications for wire routing instructions. All frequencies are continuous.
9. Refer to Appendix A for test and maintenance information

10. Maximum resistance on outputs is 10 ohms. Maximum resistance on outputs programmed as releasing, is 1 divided by current requirements of solenoid.

See Appendix C for smoke detector compatibility data.

See Battery Calculation Worksheet for battery information.

**Program #24 Mode**

1. Apply power to panel.
2. Press ENT to enter PROGRAM mode
3. Press 6 or scroll down to #6 and press ENT, (The selection is indicated by a flashing arrow next to the number.
4. Enter the password. (Factory default is 1111)
5. Press 1 or press ENT. (1 should be the highlighted selection)
6. The display shows the current program number. Press 1 to change to program 1. Press ENT.
7. Press 1 to accept the change.
8. Press ENT to accept the change.

| Single Hazard, 2<br>Detection Zones, 1<br>Manual Release Zone and<br>A Discharge Confirmation<br>Zone | PROGRAM #24              |             |           |           |                |                     |        |
|---|--------------------------|-------------|-----------|-----------|----------------|---------------------|--------|
|   | CONVENTIONAL INPUT ZONES |             |           |           |                |                     |        |
|   | #1                       | #2          | #3        | #4        | #5             | #6                  | #7     |
| OUTPUTS   | Abort                    | Supervisory | Detection | Detection | Manual Release | Low Air Supervisory | Unused |
| #1 ALARM INDICATING   |                          |             | X         | X         |                |                     |        |
| #2 ALARM INDICATING   |                          |             |           |           | X              |                     |        |
| #3 RELEASE  |                          |             | X         | X         | X              |                     |        |
| #4 SUPERVISORY  |                          | X           |           |           |                | X                   |        |

Description: Single Hazard, 2 detection zones, a manual station zone and a discharge confirmation zone.  
 Inputs: 1 supervisory zone, 1 low air zone, 2 detection zones, 1 manual station zone, 1 abort circuit  
 Outputs: 2 general alarm, 1 release circuit, 1 supervisory  
 Operation: Activation of either detection zones 3 or 4 will activate the alarm output #1 and start the pre-discharge timer for the release circuit output #3  
 Activation of the manual release zone #5 will activate the alarm output #2 and start the manual release pre-discharge timer for release circuit output #3  
 Activation of zone 6 will operate output #4

When either zone 3 or 4 is in alarm, output 1 will operate and the pre-discharge timer for output #3 will start  
 When zone 5 is in alarm, output 2 will operate and the manual release pre-discharge timer for output #3 will start.

When zone 6 is activated, output #4 will operate

Wiring Diagram Program #30  
 Failsafe Single Hazard Cross Zoned, -2 Alarm Zones, 1 Waterflow  
 Zone, 2 supervisory Zones with Manual Release

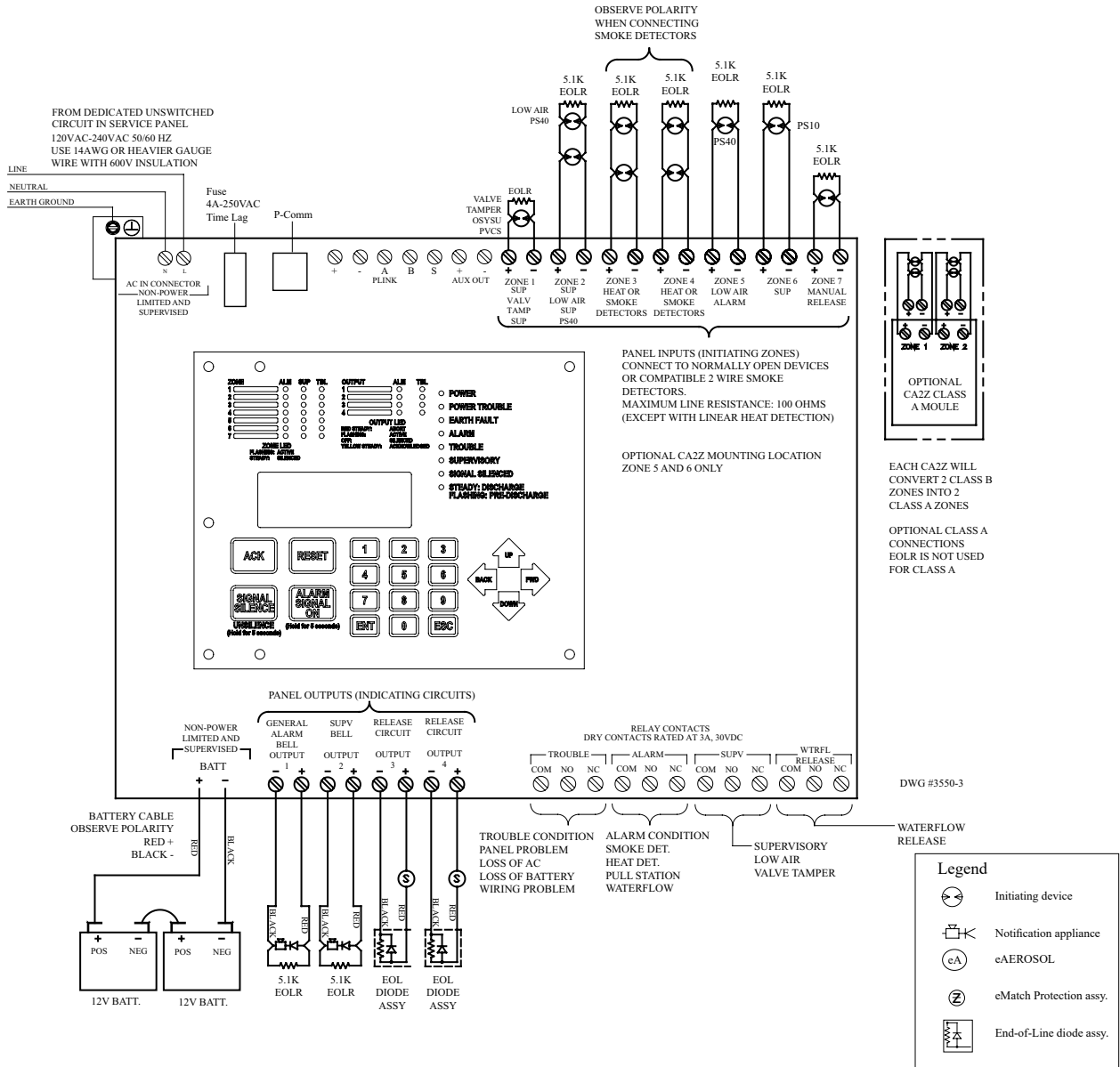

NOTES:

1. Connect only UL Listed 24VDC devices to indicating circuits.
2. Connect EOL Diode assembly IN SERIES with solenoid on release circuit
3. Install EOLR (provided) on all unused circuits.
4. Polarity is shown on indicating circuits in an activated (off-normal) condition.
5. Polarity reverses when output is activated.
6. Maximum current per output is 3 Amp. Maximum voltage is 33VDC.
7. Outputs identified as Release are Special Application. All other outputs are Regulated 24 VDC, Rated 3 Amp each, 3 Amp total for all 4 circuits.
8. All initiating and NAC/Release circuits are supervised and power limited. See Main Board Wiring Specifications for wire routing instructions. All frequencies are continuous.
9. Refer to Appendix A for test and maintenance information

10. Maximum resistance on outputs is 10 ohms. Maximum resistance on outputs programmed as releasing, is 1 divided by current requirements of solenoid.

See Appendix C for smoke detector compatibility data.

See Battery Calculation Worksheet for battery information.



**Program #30 Mode**

1. Apply power to panel.
2. Press ENT to enter PROGRAM mode
3. Press 6 or scroll down to #6 and press ENT, (The selection is indicated by a flashing arrow next to the number.
4. Enter the password. (Factory default is 1111)
5. Press 1 or press ENT. (1 should be the highlighted selection)
6. The display shows the current program number. Press 30 to change to program 30. Press ENT.
7. Press 1 to accept the change.
8. Press ENT to accept the change.

| Failsafe Cross Zoned Activation With Normally Open and Normally Closed Solenoid    | PROGRAM #30              |                     |                        |                        |                               |            |                |                   |
|--|--------------------------|---------------------|------------------------|------------------------|-------------------------------|------------|----------------|-------------------|
|  | CONVENTIONAL INPUT ZONES |                     |                        |                        |                               |            |                | SOFTWARE ZONES    |
|  | #1                       | #2                  | #3                     | #4                     | #5                            | #6         | #7             | #8                |
| OUTPUTS  | VALVE TAMPER SUPERVISORY | LOW AIR SUPERVISORY | CONVENTIONAL DETECTION | CONVENTIONAL DETECTION | LOW AIR ALARM                 | WATER FLOW | MANUAL RELEASE | RELEASE ZONE TYPE |
| #1 ALARM INDICATING (General Alarm)  |                          |                     | X                      | X                      |                               | X          | X              | X                 |
| #2 RELEASE NORMALLY ENERGIZED (Failsafe Solenoid, Drops Out on Any System Trouble) |                          |                     | X                      | X                      |                               |            | X              |                   |
| #3 RELEASE   |                          |                     | XX                     | XX                     | XX Either Zone 3 & 5 or 4 & 5 |            | X              | XX*               |
| #4 ALARM (waterflow alarm)   |                          |                     |                        |                        |                               | X          |                |                   |

\* Release Outputs which are Cross-Zoned need a Software Zone in order to work properly. The Software Zone Number will be displayed upon a release.

XX = Cross-Zoned

Inputs            2 Supervisory zones, 2 conventional detection zones, 1 Low Air Alarm zone, 1 Waterflow zone, 1 Manual release zone.

Outputs:        1 General alarm Indicating, 1 Failsafe Release Circuit: Normally Energized. de-energizes on any system trouble, 1 Release Circuit: Normally Not Energized, 1 Waterflow alarm output.

Operation:      Output 2 is constantly energized. Any trouble condition on the panel will de-energize output 2.  
 Activation of supervisory zone 1 or 2 or activation of Low Air Alarm zone 5, will only create supervisory condition on the panel.  
 Activation of Conventional Detection zone #3 and/or zone 4 will activate General alarm output 1 and De-energize output 2 .  
 Activation of either Conventional Detection zone #3 OR zone 4, AND activation of Low Air Alarm zone 5, will energize/activate release output #3.  
 Activation of Manual Release zone #7 will activate General alarm output 1, de-energize failsafe release output 2 and energize/activate release output #3.

Wiring Diagram Program #31  
 Failsafe Single Hazard, -2 Alarm Zones, 1 Waterflow Zone, 3  
 supervisory Zones with Manual Release

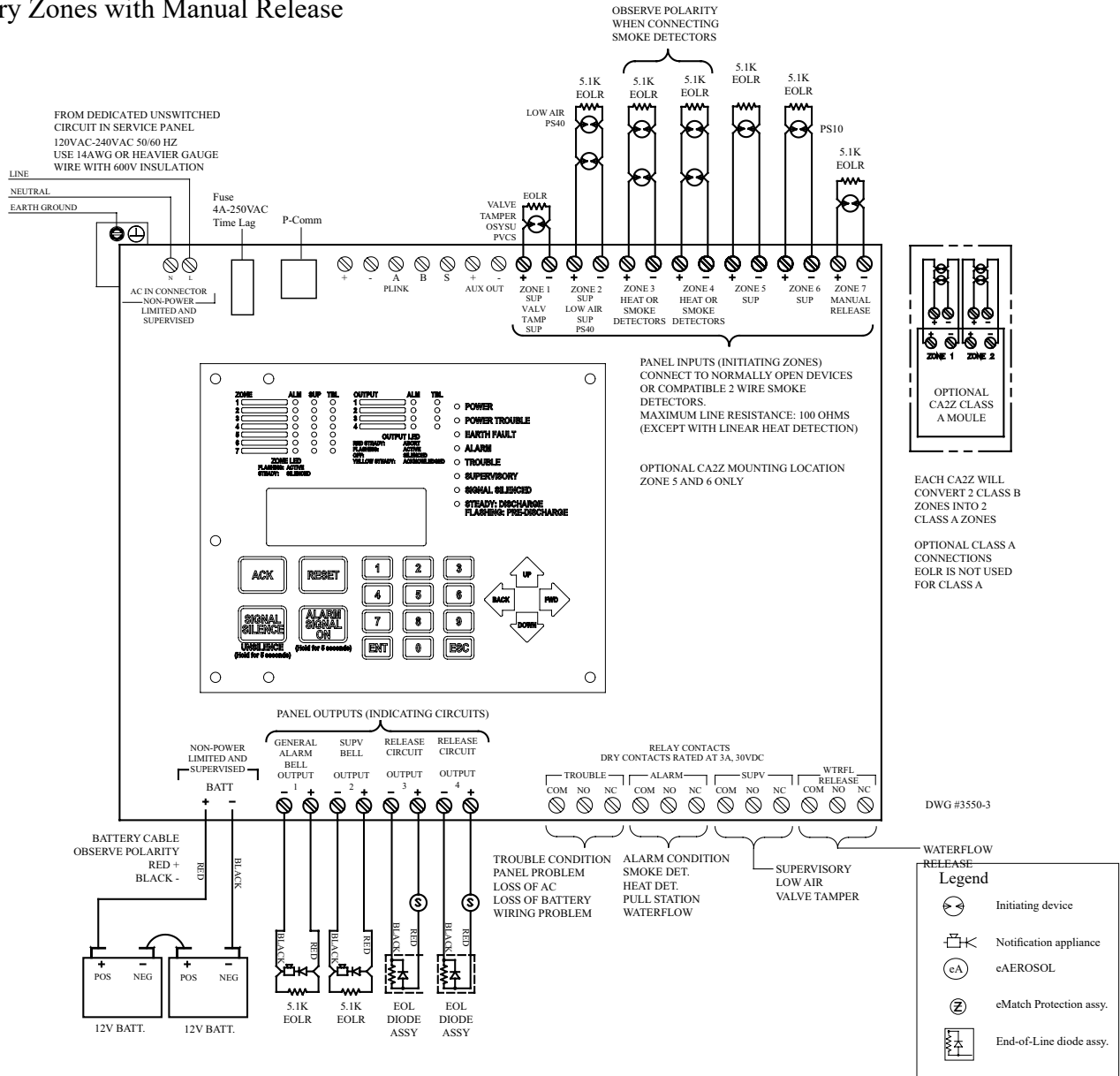

NOTES:

1. Connect only UL Listed 24VDC devices to indicating circuits.
2. Connect EOL Diode assembly IN SERIES with solenoid on release circuit
3. Install EOLR (provided) on all unused circuits.
4. Polarity is shown on indicating circuits in an activated (off-normal) condition.
5. Polarity reverses when output is activated.
6. Maximum current per output is 3 Amp. Maximum voltage is 33VDC.
7. Outputs identified as Release are Special Application. All other outputs are Regulated 24 VDC, Rated 3 Amp each, 3 Amp total for all 4 circuits.
8. All initiating and NAC/Release circuits are supervised and power limited. See Main Board Wiring Specifications for wire routing instructions. All frequencies are continuous.
9. Refer to Appendix A for test and maintenance information

10. Maximum resistance on outputs is 10 ohms. Maximum resistance on outputs programmed as releasing, is 1 divided by current requirements of solenoid.

See Appendix C for smoke detector compatibility data.

See Battery Calculation Worksheet for battery information.

**Program #31 Mode**

1. Apply power to panel.
2. Press ENT to enter PROGRAM mode
3. Press 6 or scroll down to #6 and press ENT, (The selection is indicated by a flashing arrow next to the number.
4. Enter the password. (Factory default is 1111)
5. Press 1 or press ENT. (1 should be the highlighted selection)
6. The display shows the current program number. Press 31 to change to program 31. Press ENT.
7. Press 1 to accept the change.
8. Press ENT to accept the change.

| Failsafe Operation<br>Single zone activation<br>Two solenoids, one is<br>Normally Energized       | PROGRAM #31                 |                        |                           |                           |             |           |                   |
|---|-----------------------------|------------------------|---------------------------|---------------------------|-------------|-----------|-------------------|
|   | CONVENTIONAL INPUT ZONES    |                        |                           |                           |             |           |                   |
|   | #1                          | #2                     | #3                        | #4                        | #5          | #6        | #7                |
| OUTPUTS   | VALVE TAMPER<br>SUPERVISORY | LOW AIR<br>SUPERVISORY | CONVENTIONAL<br>DETECTION | CONVENTIONAL<br>DETECTION | SUPERVISORY | WATER LOW | MANUAL<br>RELEASE |
| #1 ALARM INDICATING<br>(General Alarm)  |                             |                        | X                         | X                         |             | X         | X                 |
| #2 RELEASE<br>NORMALLY<br>ENERGIZED<br>(Failsafe Solenoid, Drops<br>Out on Any System<br>Trouble) |                             |                        | X                         | X                         |             |           | X                 |
| #3 RELEASE (Solenoid)   |                             |                        | X                         | X                         |             |           | X                 |
| #4 ALARM (waterflow<br>alarm)   |                             |                        |                           |                           |             | X         |                   |

Inputs: 3 Supervisory zones, 2 conventional detection zones, 1 Waterflow zone, 1 Manual release zone  
 Outputs: 1 General alarm Indicating, 1 Release Circuit: Normally Energized. Failsafe, De-energizes on any system trouble, 1 Release Circuit: Normally Not Energized, 1 Waterflow alarm output.

Operation: Output 2 is constantly energized. Any trouble condition on the panel will de-energize output 2. Activation of Supervisory zone 1, zone 2 or Low Diaphragm water Pressure zone 5, will create a supervisory condition on the panel.  
 Activation of Conventional Detection zone 3 or zone 4, or Manual Release zone 7 will activate General alarm output 1, De-energize output 2 and energize/activate release output 3.  
 Activation of Waterflow zone 6 will activate General alarm output 1 and Waterflow alarm output 4.  
 Activation of Manual Release zone #7 will activate General alarm output 1, de-energize failsafe release output 2 and energize/activate release output #3.

Wiring Diagram Program #32

Double Interlock with Redundant Solenoids Crossed Zone - 3 Supervisory zones, 2 Detection zones, 1 Waterflow zone, 1 Manual Release zone

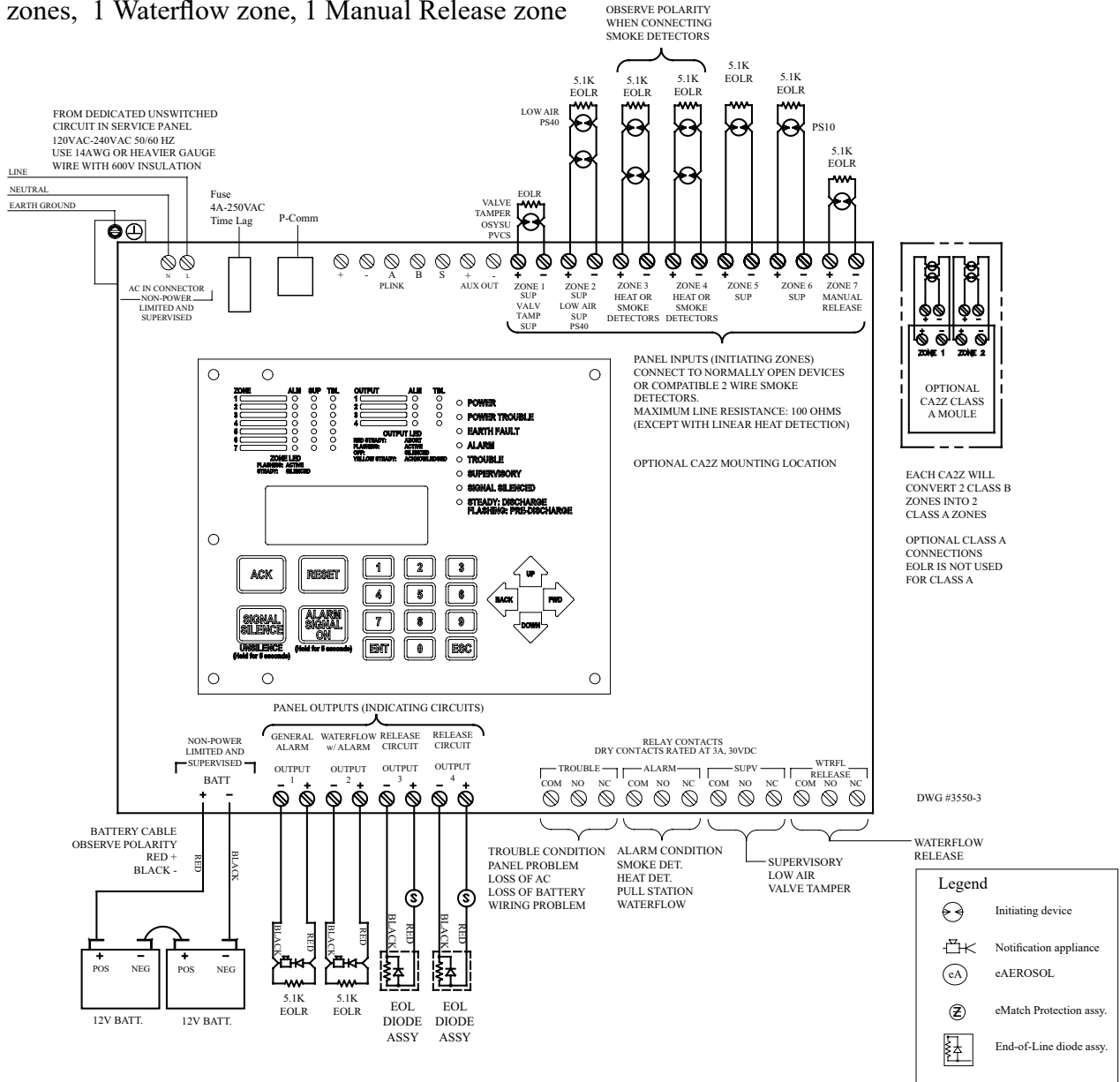

NOTES:

1. Connect only UL Listed 24VDC devices to indicating circuits.
2. Connect EOL Diode assembly IN SERIES with solenoid on release circuit
3. Install EOLR (provided) on all unused circuits.
4. Polarity is shown on indicating circuits in an activated (off-normal) condition.
5. Polarity reverses when output is activated.
6. Maximum current per output is 3 Amp. Maximum voltage is 33VDC.
7. Outputs identified as Release are Special Application. All other outputs are Regulated 24 VDC, Rated 3 Amp each, 3 Amp total for all 4 circuits.
8. All initiating and NAC/Release circuits are supervised and power limited. See Main Board Wiring Specifications for wire routing instructions. All frequencies are continuous.
9. Refer to Appendix A for test and maintenance information

10. Maximum resistance on outputs is 10 ohms. Maximum resistance on outputs programmed as releasing, is 1 divided by current requirements of solenoid.

See Appendix C for smoke detector compatibility data.

See Battery Calculation Worksheet for battery information.

**Program #32 Mode**

1. Apply power to panel.
2. Press ENT to enter PROGRAM mode
3. Press 6 or scroll down to #6 and press ENT, (The selection is indicated by a flashing arrow next to the number.)
4. Enter the password. (Factory default is 1111)
5. Press 1 or press ENT. (1 should be the highlighted selection)
6. The display shows the current program number. Press 32 to change to program 32. Press ENT.
7. Press 1 to accept the change.
8. Press ENT to accept the change.

| Double Interlock with Redundant Solenoids Cross Zoned Activation | PROGRAM #32              |              |                        |                        |                             |           |                |                   |                   |
|--|--------------------------|--------------|------------------------|------------------------|-----------------------------|-----------|----------------|-------------------|-------------------|
|  | CONVENTIONAL INPUT ZONES |              |                        |                        |                             |           |                | SOFTWARE ZONES    |                   |
|  | #1                       | #2           | #3                     | #4                     | #5                          | #6        | #7             | #8                | #9                |
| OUTPUTS  | Low Air Supervisory      | Valve Tamper | Conventional Detection | Conventional Detection | Low Air Alarm               | Waterflow | Manual Release | Release Zone Type | Release Zone Type |
| #1 GENERAL ALARM   |                          |              | X                      | X                      |                             | X         | X              | X                 | X                 |
| #2 WATERFLOW ALARM   |                          |              |                        |                        |                             | X         |                |                   |                   |
| #3 RELEASE SOLENOID  |                          |              | XX                     | XX                     | XX Either Zones 3 &5 or 4&5 |           | X              | XX*               | XX*               |
| #4 RELEASE SOLENOID  |                          |              | XX                     | XX                     | XX Either Zones 3 &5 or 4&5 |           | X              | XX*               | XX*               |

\* Release Outputs which are Cross-Zoned need a Software Zone in order to work properly. The Software Zone Number will be displayed upon a release.

XX = Cross-Zoned

Inputs: 3 Supervisory zones, 2 Detection zones, 1 Waterflow zone, 1 Manual Release zone

Outputs: 1 General Alarm, 1 Waterflow, 2 Release Solenoids

Operation: Activation of any supervisory zone or Low Air Alarm zone will create a supervisory condition on the panel, no outputs will activate  
 Activation of Conventional Detection zone 3 and/or 4 will activate General Alarm output 1  
 Activation of either Conventional Detection zone 3 OR 4 AND Low Air Alarm zone 5 will activate General Alarm output 1 and Release Solenoid outputs 3 and 4.  
 Activation of Waterflow zone 6 will activate General alarm output 1 and Waterflow output 2.  
 Activation of Manual Release zone #7 will activate General Alarm output 1 and Release Solenoid outputs 3 and 4.

# Wiring Diagram Program #33 Redundant Solenoids Single Interlock with Single Zone Activation

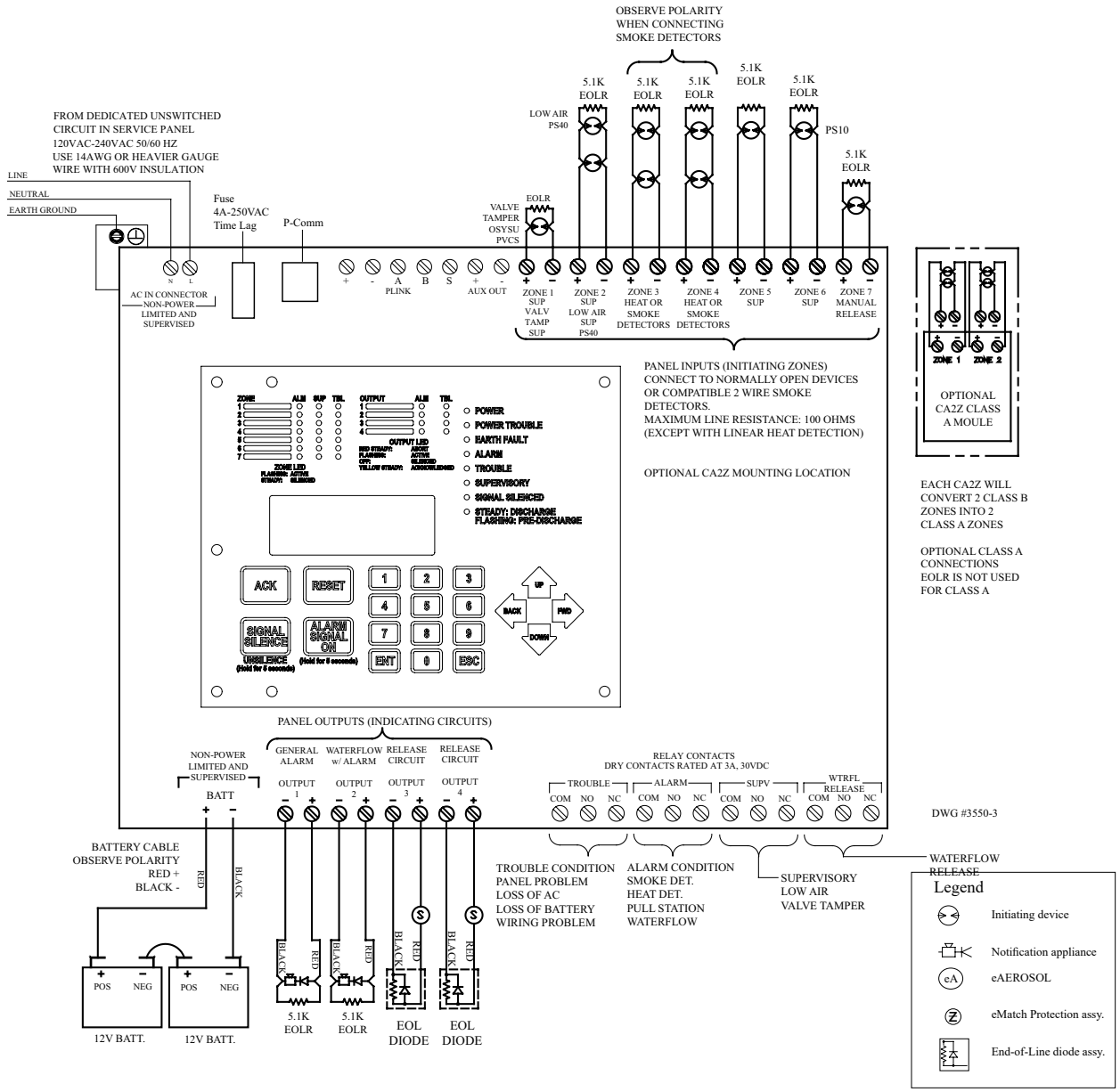

**Program #33 Mode**

1. Apply power to panel.
2. Press ENT to enter PROGRAM mode
3. Press 6 or scroll down to #6 and press ENT, (The selection is indicated by a flashing arrow next to the number.
4. Enter the password. (Factory default is 1111)
5. Press 1 or press ENT. (1 should be the highlighted selection)
6. The display shows the current program number. Press 33 to change to program 33. Press ENT.
7. Press 1 to accept the change.
8. Press ENT to accept the change.

| Redundant Solenoids<br>Single Interlock with Single<br>Zone Activation | PROGRAM #33            |                 |                           |                           |                  |           |                   |
|--|------------------------|-----------------|---------------------------|---------------------------|------------------|-----------|-------------------|
|  | ZONES                  |                 |                           |                           |                  |           |                   |
|  | #1                     | #2              | #3                        | #4                        | #5               | #6        | #7                |
| OUTPUTS  | Low Air<br>Supervisory | Valve<br>Tamper | Conventional<br>Detection | Conventional<br>Detection | Low Air<br>Alarm | Waterflow | Manual<br>Release |
| #1 GENERAL ALARM   |                        |                 | X                         | X                         |                  | X         | X                 |
| #2 WATERFLOW ALARM   |                        |                 |                           |                           |                  | X         |                   |
| #3 RELEASE SOLENOID  |                        |                 | X                         | X                         |                  |           | X                 |
| #4 RELEASE SOLENOID  |                        |                 | X                         | X                         |                  |           | X                 |

Inputs: 3 Supervisory zones, 2 Detection zones, 1 Waterflow zone, 1 Manual Release zone

Outputs: 1 General Alarm, 1 Waterflow, 2 Release Solenoids

Operation: Activation of any supervisory zone or Low Air Alarm zone will create a supervisory condition on the panel, no outputs will activate  
 Activation of Conventional Detection zone 3 and/or 4 and/or Manual Release zone 7 will activate General Alarm output 1 and Release Solenoid outputs 3 and 4  
 Activation of Waterflow zone 6 will activate General alarm output 1 and Waterflow output 2

Wiring Diagram Program #34  
Single Hazard Latching Solenoid with Remote reset

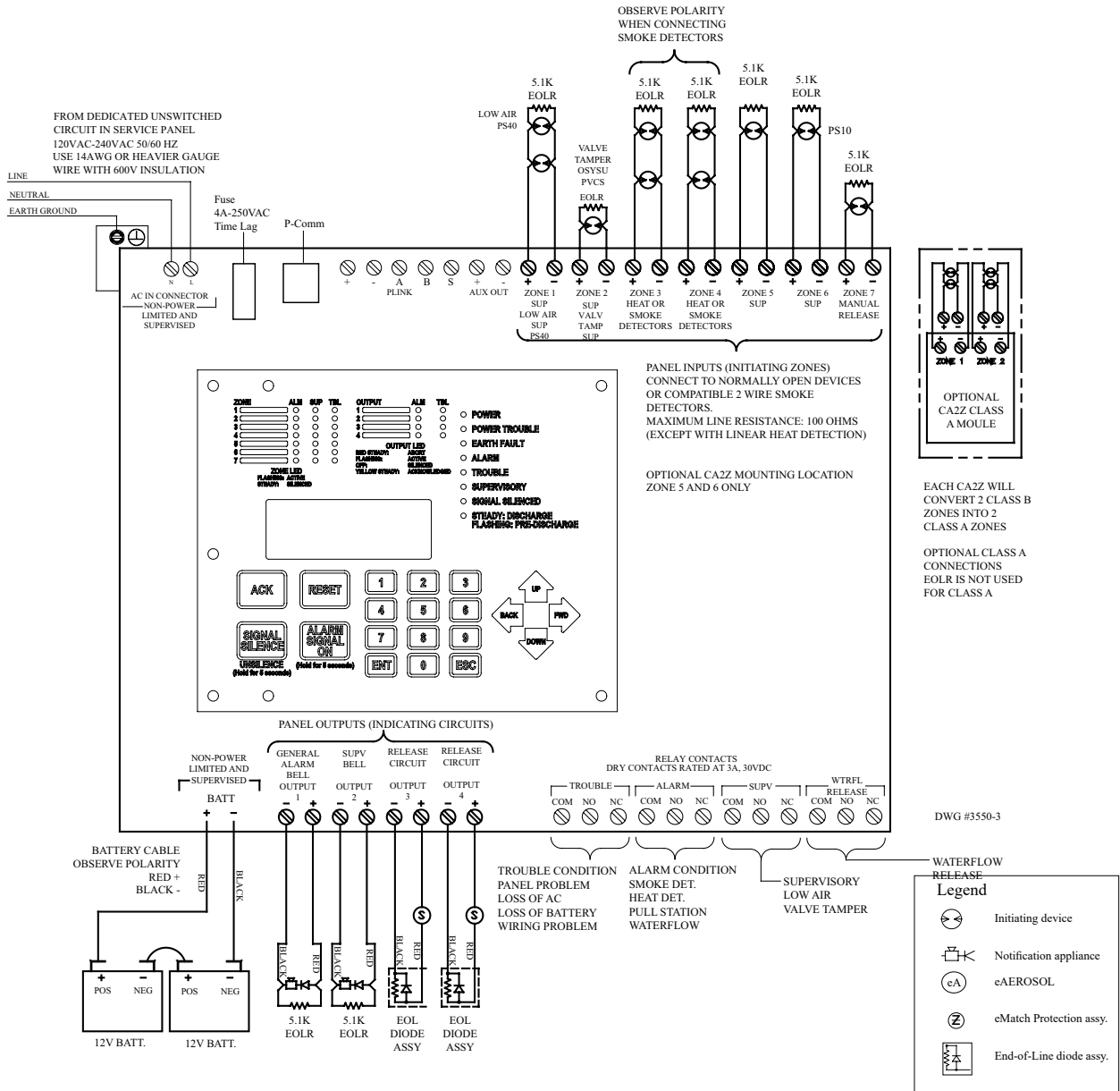



**Program #34 Mode**

1. Apply power to panel.
2. Press ENT to enter PROGRAM mode
3. Press 6 or scroll down to #6 and press ENT, (The selection is indicated by a flashing arrow next to the number.
4. Enter the password. (Factory default is 1111)
5. Press 1 or press ENT. (1 should be the highlighted selection)
6. The display shows the current program number. Press 1 to change to program 1. Press ENT.
7. Press 1 to accept the change.
8. Press ENT to accept the change.

| Single Zone Activation:<br>Latching Solenoid<br>Remote Solenoid Reset | PROGRAM #34            |                 |                           |                           |                            |           |                   |
|---|------------------------|-----------------|---------------------------|---------------------------|----------------------------|-----------|-------------------|
|   | ZONES                  |                 |                           |                           |                            |           |                   |
|   | #1                     | #2              | #3                        | #4                        | #5                         | #6        | #7                |
| OUTPUTS   | Low Air<br>Supervisory | Valve<br>Tamper | Conventional<br>Detection | Conventional<br>Detection | Valve Reset<br>Supervisory | Waterflow | Manual<br>Release |
| #1 GENERAL ALARM  |                        |                 | X                         | X                         |                            |           | X                 |
| #2 RELEASE SOLENOID (2<br>second pulse)                               |                        |                 | X                         | X                         |                            |           | X                 |
| #3 SOLENOID RESET (2<br>second pulse)                                 |                        |                 |                           |                           | X                          |           |                   |
| #4 WATERFLOW BELL   |                        |                 |                           |                           |                            | X         |                   |

- Inputs: 2 Supervisory zones, 2 conventional detection zones, 1 Waterflow zone, 1 Manual release zone, 1 Valve Reset zone
- Outputs: 1 General alarm Indicating, 1 Release circuit, 1 Valve Reset circuit, 1 Waterflow Bell
- Operation: Activation of Supervisory zone 1 or 2 will create a supervisory condition on the panel  
 Activation of Conventional Detection zone 3 or 4 will activate General alarm output 1 and temporarily activate release output 2 for two seconds  
 Activation of Valve Reset zone 5 will temporarily activate release output 3 to reset the solenoid on the preaction valve and create a supervisory condition  
 Activation of Waterflow zone 6 will activate the waterflow bell output 4  
 Activation of Manual Release zone #7 will activate General alarm output 1 and temporarily energize release output #2

Wiring Diagram Program #35

Single Hazard Latching Solenoid Cross Zoned with Remote reset

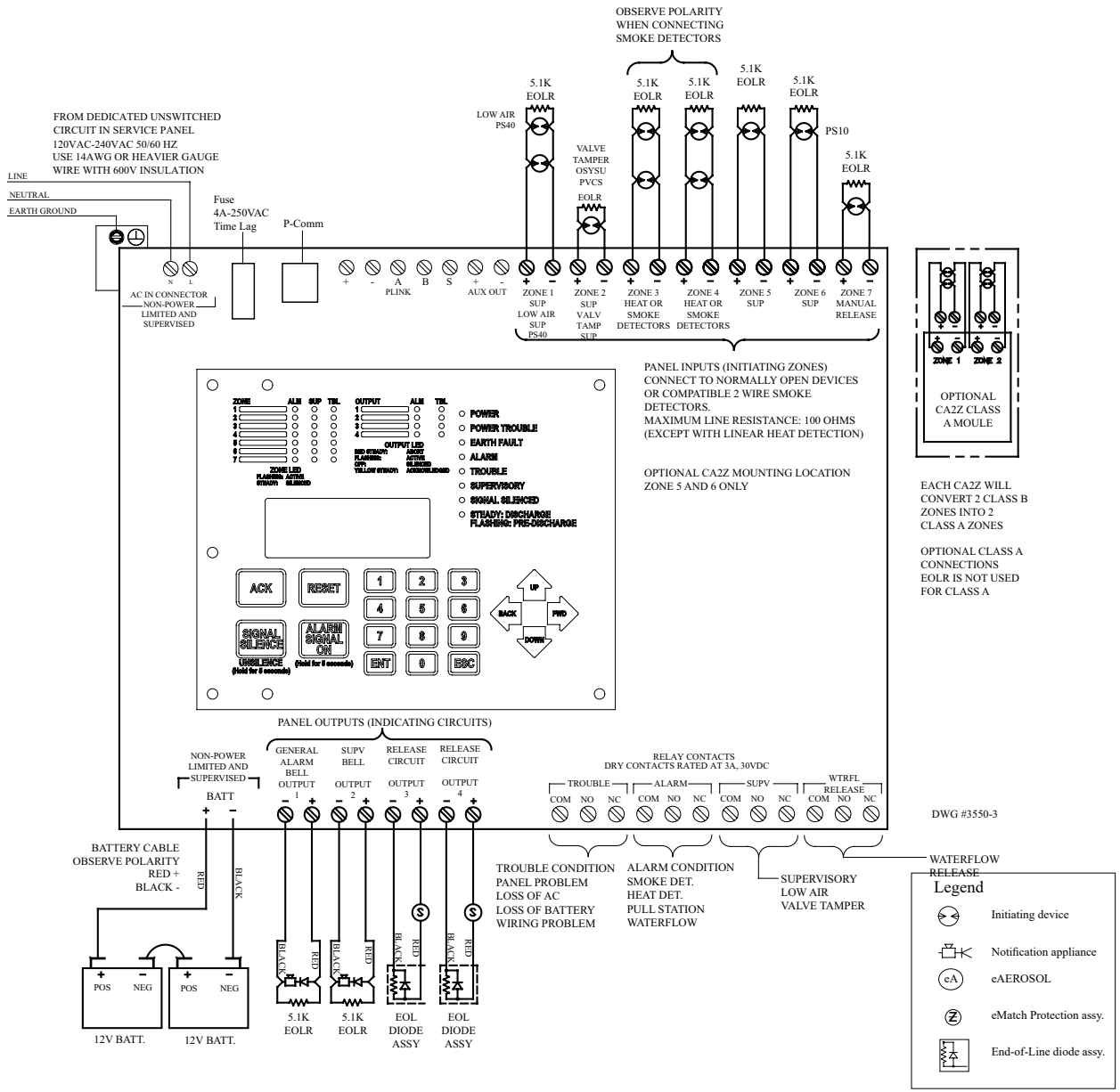

NOTES:

1. Connect only UL Listed 24VDC devices to indicating circuits.
2. Connect EOL Diode assembly IN SERIES with solenoid on release circuit
3. Install EOLR (provided) on all unused circuits.
4. Polarity is shown on indicating circuits in an activated (off-normal) condition.
5. Polarity reverses when output is activated.
6. Maximum current per output is 3 Amp. Maximum voltage is 33VDC.
7. Outputs identified as Release are Special Application. All other outputs are Regulated 24 VDC, Rated 3 Amp each, 3 Amp total for all 4 circuits.
8. All initiating and NAC/Release circuits are supervised and power limited. See Main Board Wiring Specifications for wire routing instructions. All frequencies are continuous.
9. Refer to Appendix A for test and maintenance information

10. Maximum resistance on outputs is 10 ohms. Maximum resistance on outputs programmed as releasing, is 1 divided by current requirements of solenoid.

See Appendix C for smoke detector compatibility data.

See Battery Calculation Worksheet for battery information.

**Program #35 Mode**

1. Apply power to panel.
2. Press ENT to enter PROGRAM mode
3. Press 6 or scroll down to #6 and press ENT, (The selection is indicated by a flashing arrow next to the number.
4. Enter the password. (Factory default is 1111)
5. Press 1 or press ENT. (1 should be the highlighted selection)
6. The display shows the current program number. Press 1 to change to program 1. Press ENT.
7. Press 1 to accept the change.
8. Press ENT to accept the change.

| Latching Solenoid<br>Cross Zoned     | PROGRAM #35              |                     |                        |               |                         |            |                |                   |
|--------------------------------------|--------------------------|---------------------|------------------------|---------------|-------------------------|------------|----------------|-------------------|
|                                      | CONVENTIONAL INPUT ZONES |                     |                        |               |                         |            |                | SOFTWARE ZONES    |
|                                      | #1                       | #2                  | #3                     | #4            | #5                      | #6         | #7             | #8                |
| OUTPUTS                              | VALVE TAMPER SUPERVISORY | LOW AIR SUPERVISORY | CONVENTIONAL DETECTION | LOW AIR ALARM | VALVE RESET SUPERVISORY | WATER FLOW | MANUAL RELEASE | RELEASE ZONE TYPE |
| #1 GENERAL ALARM                     |                          |                     | X                      |               |                         |            | X              | X                 |
| #2 RELEASE SOLENOID (2 second pulse) |                          |                     | XX                     | XX            |                         |            | X              | XX*               |
| #3 SOLENOID RESET (2 second pulse)   |                          |                     |                        |               | X                       |            |                |                   |
| #4 WATERFLOW BELL                    |                          |                     |                        |               |                         | X          |                |                   |

\* Release Outputs which are Cross-Zoned need a Pseudo Zone in order to work properly. The Pseudo Zone Number will be displayed upon a release.

XX = Cross-Zoned

- Inputs: 2 Supervisory zones, 1 conventional detection zone, 1 Low Air Alarm zone, 1 Waterflow zone, 1 Manual release zone, 1 Valve reset zone
- Outputs: 1 General alarm Indicating, 1 Release circuit, 1 Valve Reset circuit, 1 Waterflow Bell
- Operation: Activation of Conventional Detection zone #3 and Low Air Alarm zone #4 at the same time or activation of Manual Release zone #7 will activate and energize release output #2  
 Activation of Low Air Alarm zone 4 will create a supervisory condition on the panel  
 Activation of Valve Reset zone 5 will reset the solenoid on the preaction valve for two seconds  
 Activation of Waterflow zone 6 will activate the waterflow bell output 4

| CUSTOM PROGRAM |                    |    |    |    |    |    |    |
|----------------|--------------------|----|----|----|----|----|----|
|                | CONVENTIONAL ZONES |    |    |    |    |    |    |
|                | #1                 | #2 | #3 | #4 | #5 | #6 | #7 |
| OUTPUTS        |                    |    |    |    |    |    |    |
| #1             |                    |    |    |    |    |    |    |
| #2             |                    |    |    |    |    |    |    |
| #3             |                    |    |    |    |    |    |    |
| #4             |                    |    |    |    |    |    |    |

