



**TECHNICAL DATA**

**FRAME STYLE  
SPRAY NOZZLE  
WATER DISTRIBUTION PATTERNS**

The Viking Corporation, 210 N Industrial Park Drive, Hastings MI 49058

Telephone: 269-945-9501 Technical Services: 877-384-5464 Fax: 269-818-1680 Email: techsvcs@vikingcorp.com

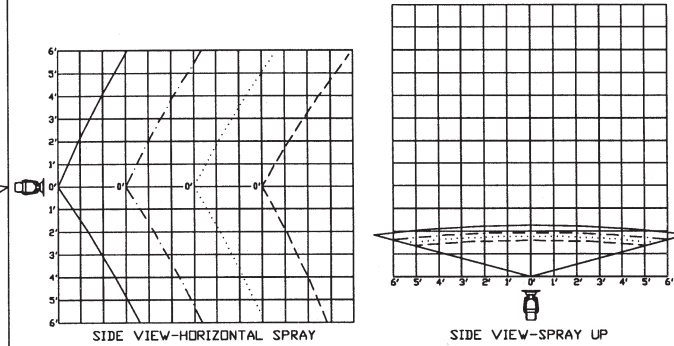
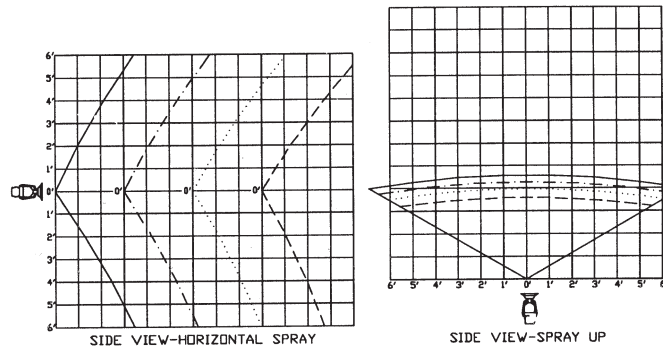
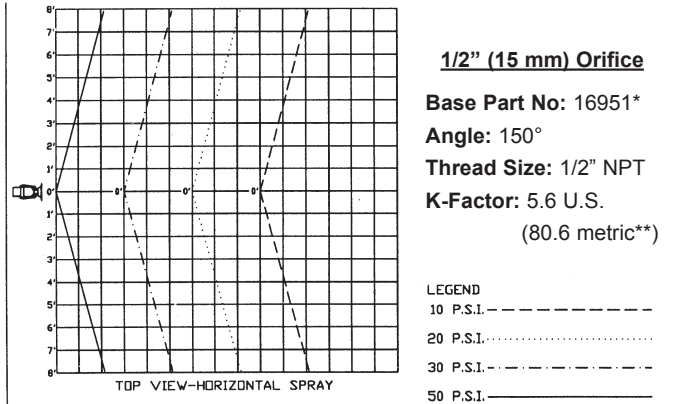
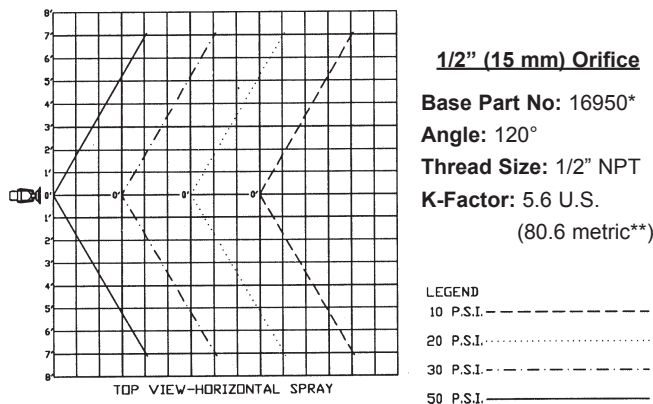
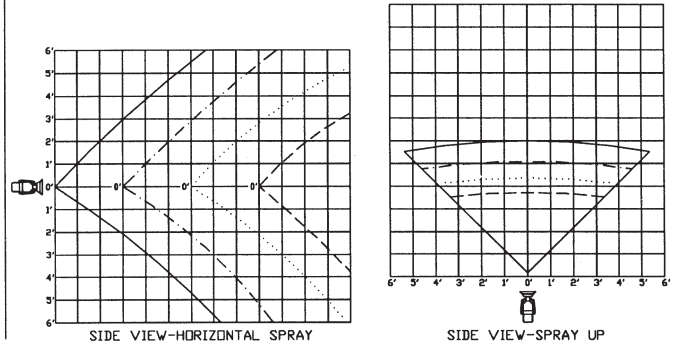
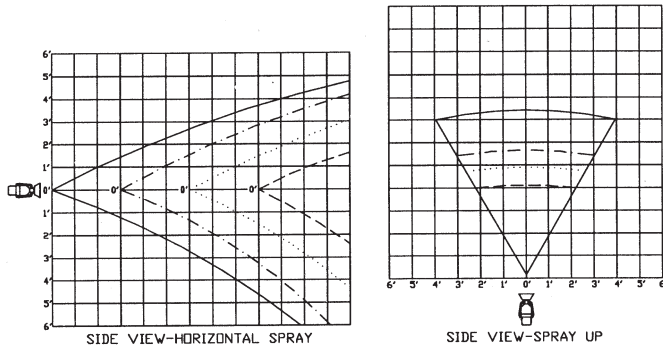
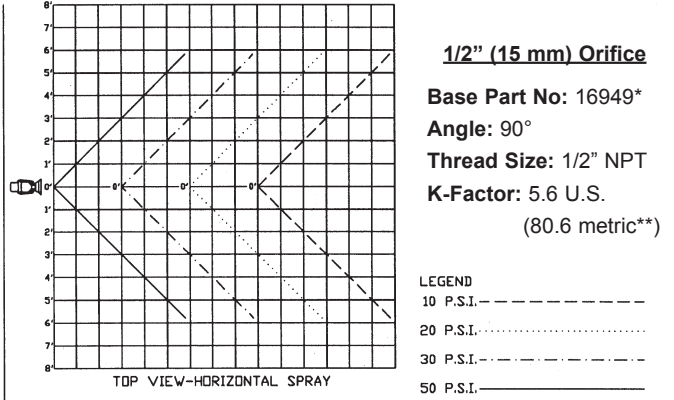
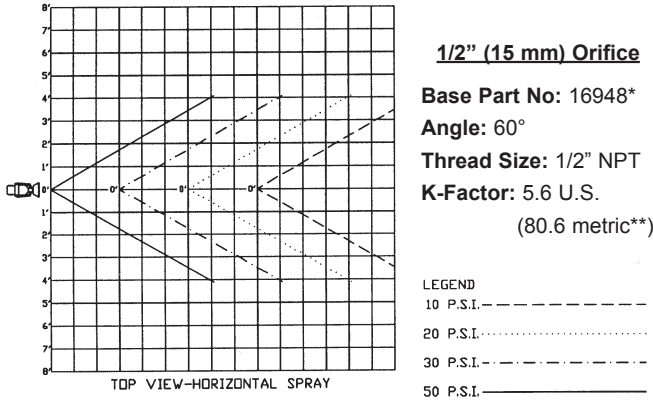

Scale: Each square equals one square foot.

\* Part number shown is the base part number. For complete part number, refer to current Viking price list schedule.

\*\*Metric K-factor measurement shown is when pressure is measured in Bar. When pressure is measured in kPa, divide the metric K-factor shown by 10.0.



TECHNICAL DATA

FRAME STYLE  
SPRAY NOZZLE  
WATER DISTRIBUTION PATTERNS

The Viking Corporation, 210 N Industrial Park Drive, Hastings MI 49058

Telephone: 269-945-9501 Technical Services: 877-384-5464 Fax: 269-818-1680 Email: techsvcs@vikingcorp.com

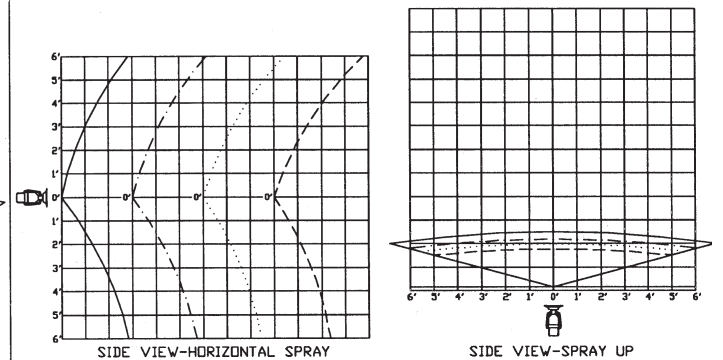
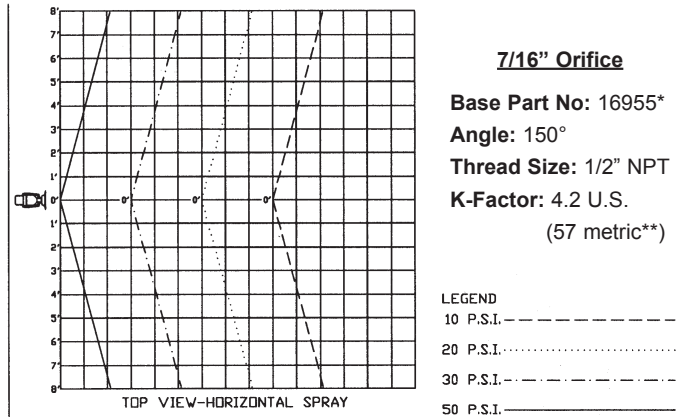
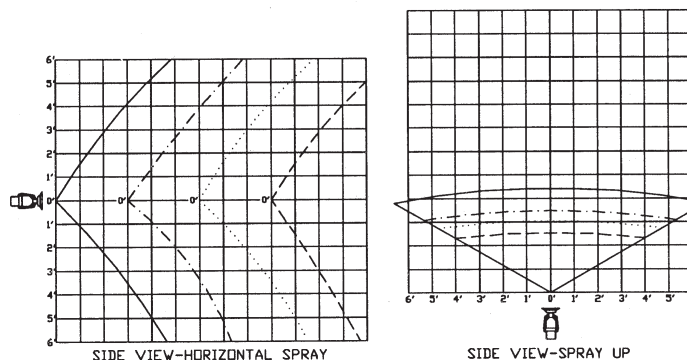
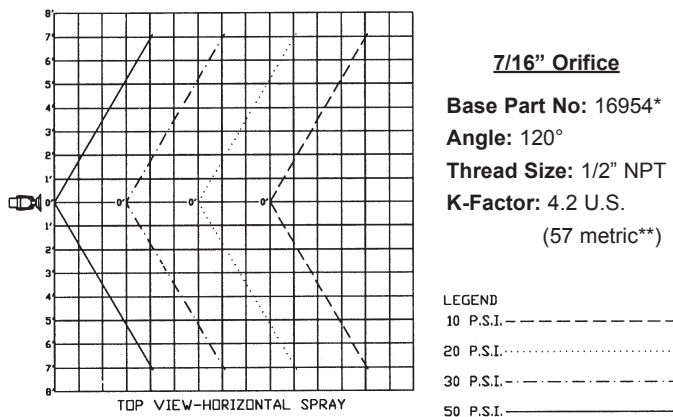
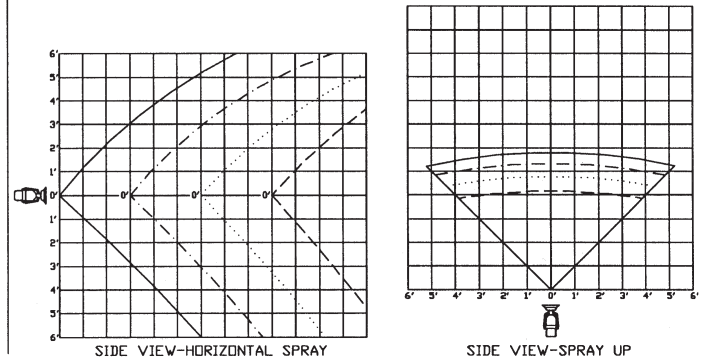
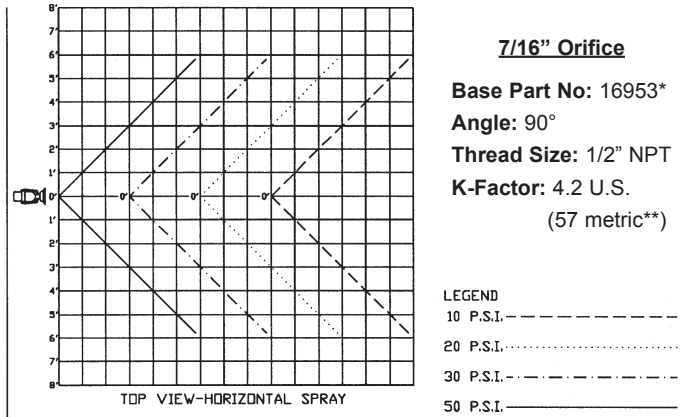
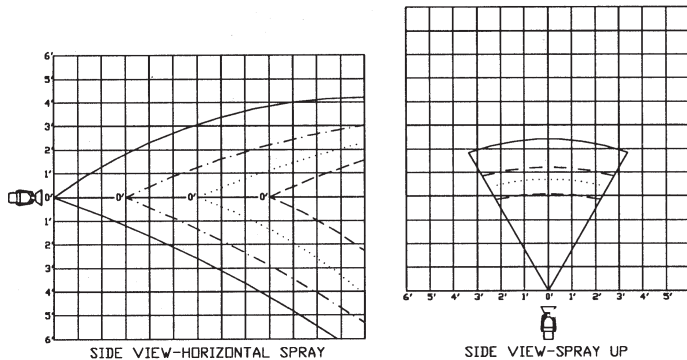
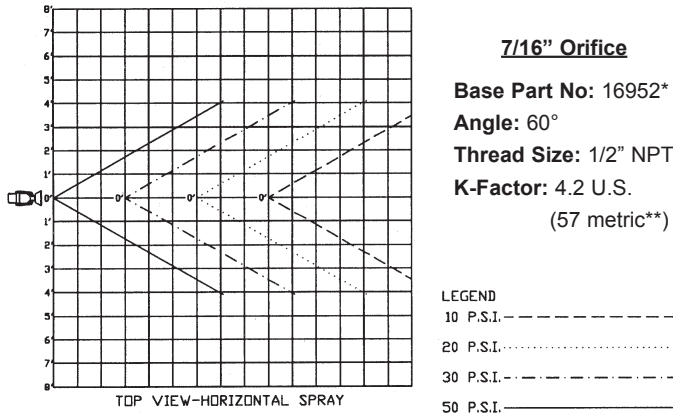

Scale: Each square equals one square foot.

\* Part number shown is the base part number. For complete part number, refer to current Viking price list schedule.

\*\*Metric K-factor measurement shown is when pressure is measured in Bar. When pressure is measured in kPa, divide the metric K-factor shown by 10.0.



TECHNICAL DATA

FRAME STYLE  
SPRAY NOZZLE  
WATER DISTRIBUTION PATTERNS

The Viking Corporation, 210 N Industrial Park Drive, Hastings MI 49058

Telephone: 269-945-9501 Technical Services: 877-384-5464 Fax: 269-818-1680 Email: techsvcs@vikingcorp.com

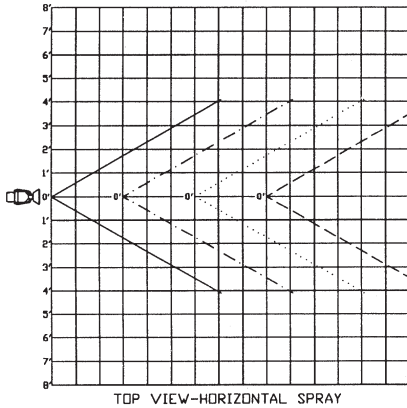

**3/8" (10 mm) Orifice**  
**Base Part No: 16956\***  
**Angle: 60°**  
**Thread Size: 1/2" NPT**  
**K-Factor: 2.8 U.S.**  
 (40.3 metric\*\*)

LEGEND  
 10 P.S.I. - - - - -  
 20 P.S.I. ······  
 30 P.S.I. - · - · -  
 50 P.S.I. \_\_\_\_\_

TOP VIEW-HORIZONTAL SPRAY

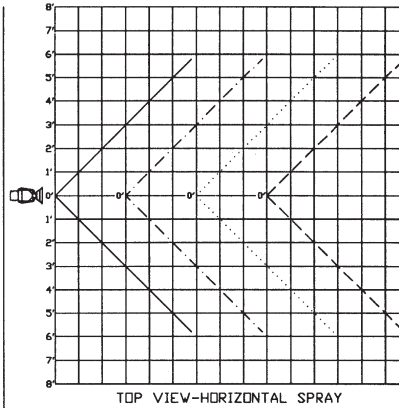

**3/8" (10 mm) Orifice**  
**Base Part No: 16957\***  
**Angle: 90°**  
**Thread Size: 1/2" NPT**  
**K-Factor: 2.8 U.S.**  
 (40.3 metric\*\*)

LEGEND  
 10 P.S.I. - - - - -  
 20 P.S.I. ······  
 30 P.S.I. - · - · -  
 50 P.S.I. \_\_\_\_\_

TOP VIEW-HORIZONTAL SPRAY

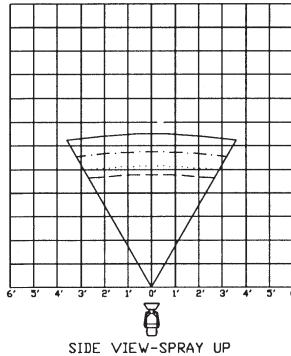
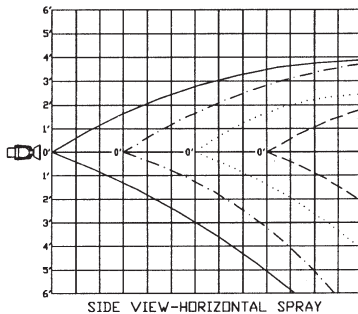

SIDE VIEW-HORIZONTAL SPRAY

SIDE VIEW-SPRAY UP

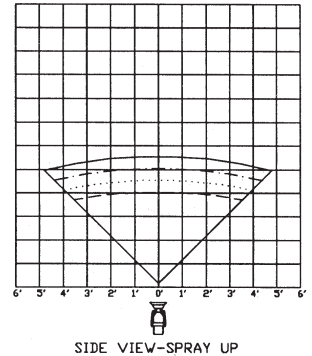
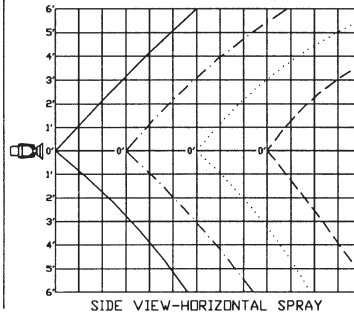

SIDE VIEW-HORIZONTAL SPRAY

SIDE VIEW-SPRAY UP

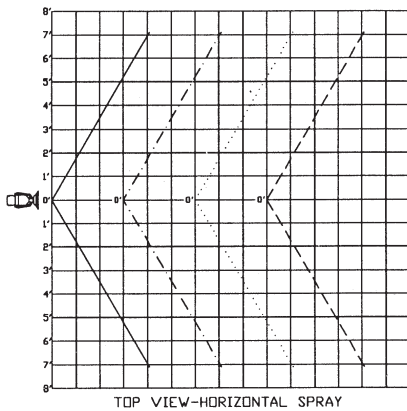

**3/8" (10 mm) Orifice**  
**Base Part No: 16958\***  
**Angle: 120°**  
**Thread Size: 1/2" NPT**  
**K-Factor: 2.8 U.S.**  
 (40.3 metric\*\*)

LEGEND  
 10 P.S.I. - - - - -  
 20 P.S.I. ······  
 30 P.S.I. - · - · -  
 50 P.S.I. \_\_\_\_\_

TOP VIEW-HORIZONTAL SPRAY

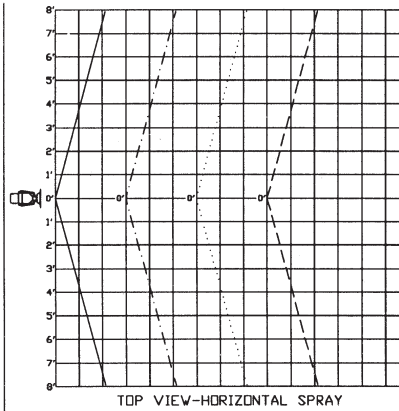

**3/8" (10 mm) Orifice**  
**Base Part No: 16959\***  
**Angle: 150°**  
**Thread Size: 1/2" NPT**  
**K-Factor: 2.8 U.S.**  
 (40.3 metric\*\*)

LEGEND  
 10 P.S.I. - - - - -  
 20 P.S.I. ······  
 30 P.S.I. - · - · -  
 50 P.S.I. \_\_\_\_\_

TOP VIEW-HORIZONTAL SPRAY

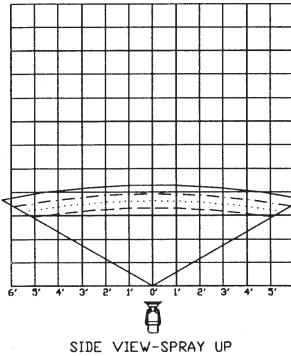
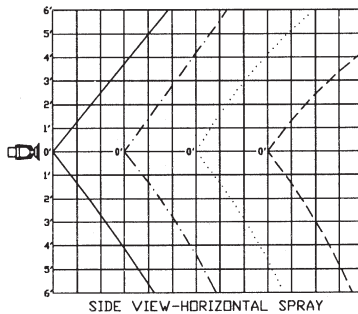

SIDE VIEW-HORIZONTAL SPRAY

SIDE VIEW-SPRAY UP

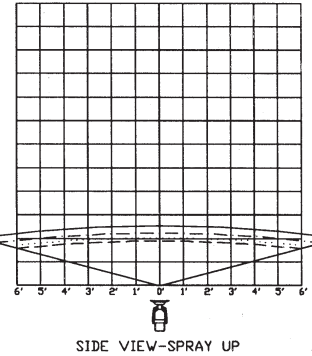
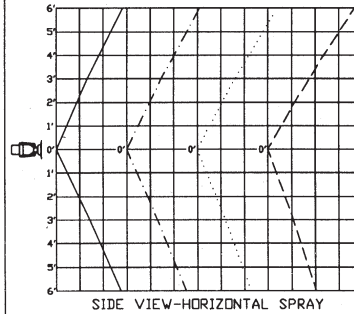

SIDE VIEW-HORIZONTAL SPRAY

SIDE VIEW-SPRAY UP

Scale: Each square equals one square foot.

\* Part number shown is the base part number. For complete part number, refer to current Viking price list schedule.

\*\*Metric K-factor measurement shown is when pressure is measured in Bar. When pressure is measured in kPa, divide the metric K-factor shown by 10.0.



TECHNICAL DATA

FRAME STYLE  
SPRAY NOZZLE  
WATER DISTRIBUTION PATTERNS

The Viking Corporation, 210 N Industrial Park Drive, Hastings MI 49058

Telephone: 269-945-9501 Technical Services: 877-384-5464 Fax: 269-818-1680 Email: techsvcs@vikingcorp.com

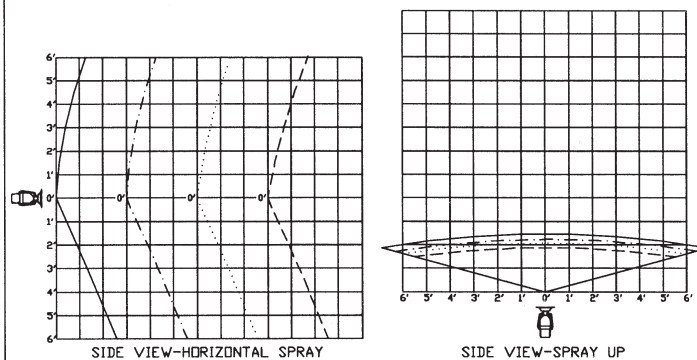
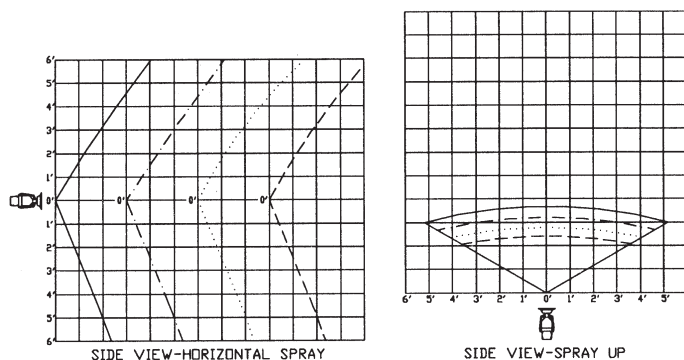
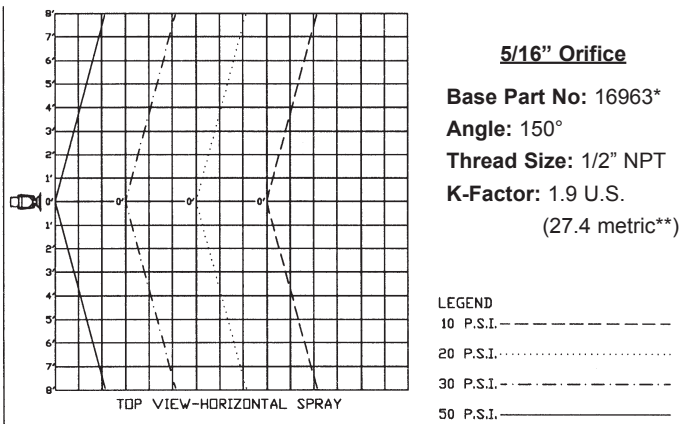
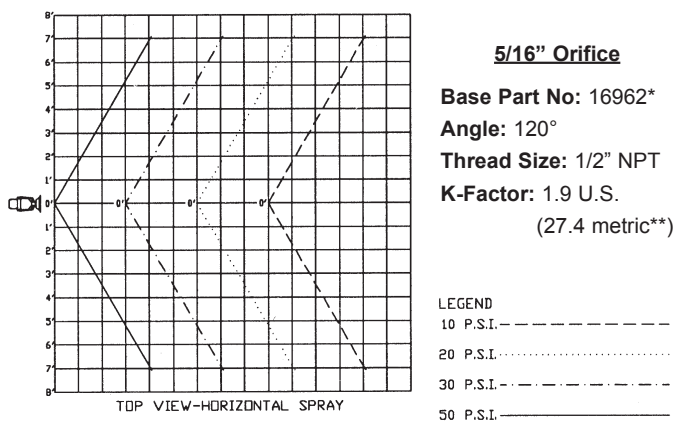
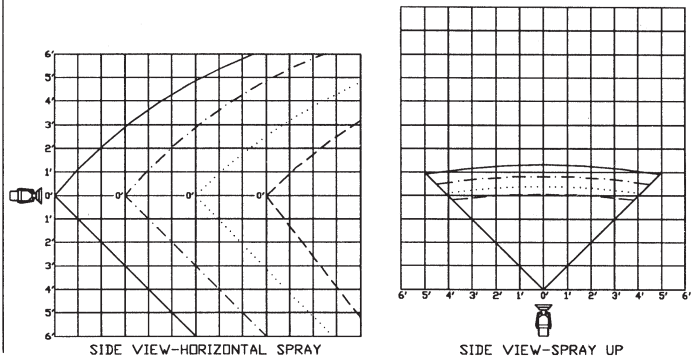
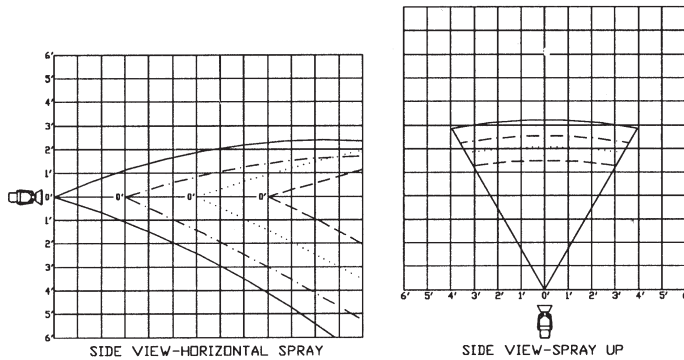
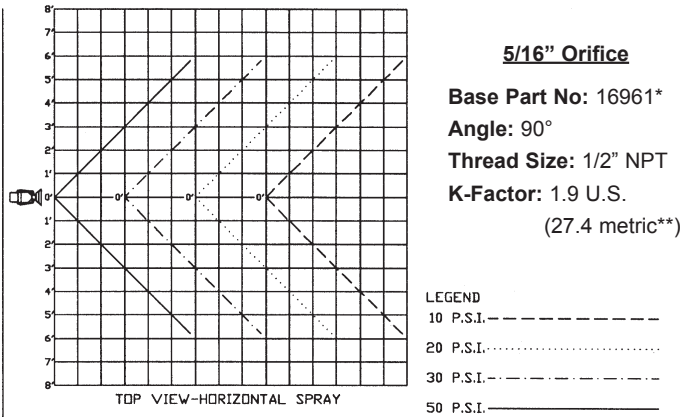
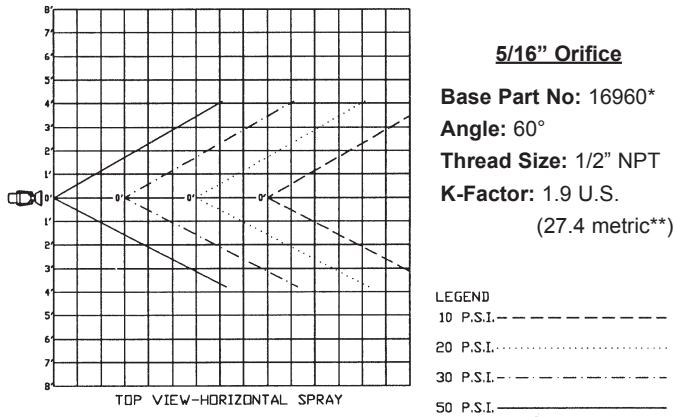

Scale: Each square equals one square foot.

\* Part number shown is the base part number. For complete part number, refer to current Viking price list schedule.

\*\*Metric K-factor measurement shown is when pressure is measured in Bar. When pressure is measured in kPa, divide the metric K-factor shown by 10.0.



TECHNICAL DATA

FRAME STYLE  
SPRAY NOZZLE  
WATER DISTRIBUTION PATTERNS

The Viking Corporation, 210 N Industrial Park Drive, Hastings MI 49058

Telephone: 269-945-9501 Technical Services: 877-384-5464 Fax: 269-818-1680 Email: techsvcs@vikingcorp.com

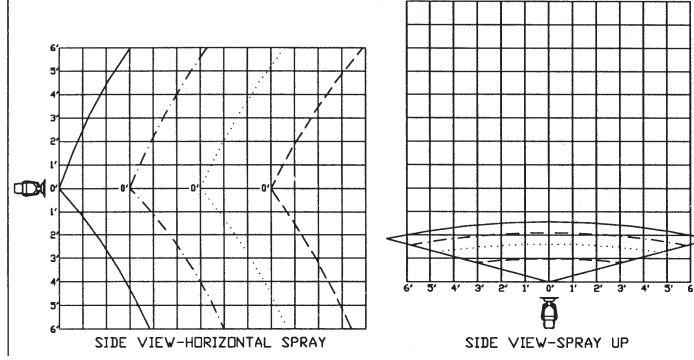
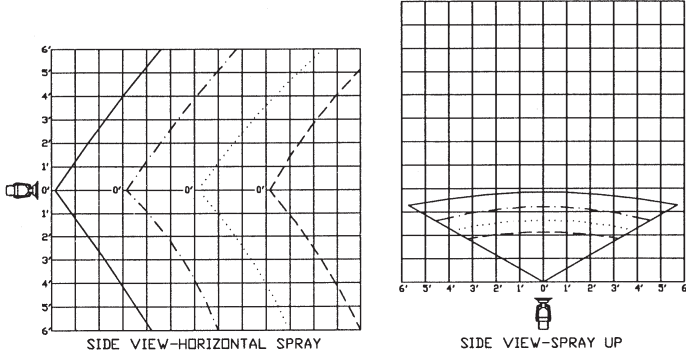
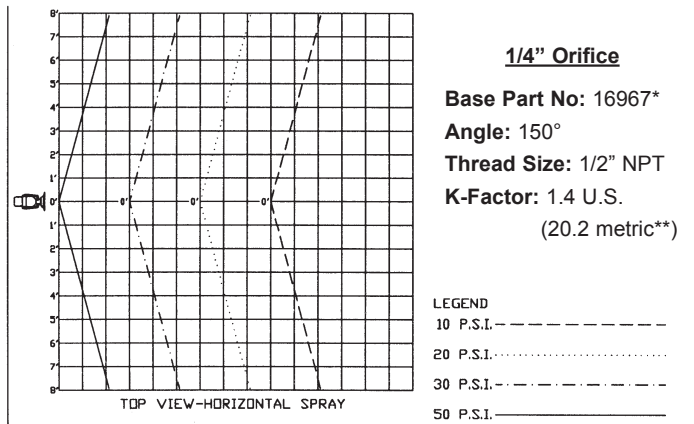
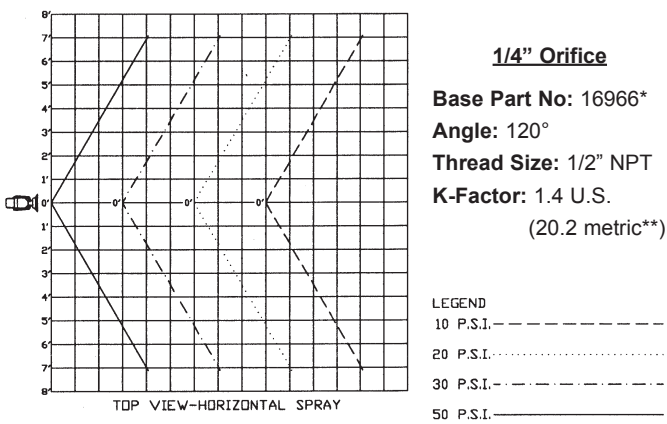
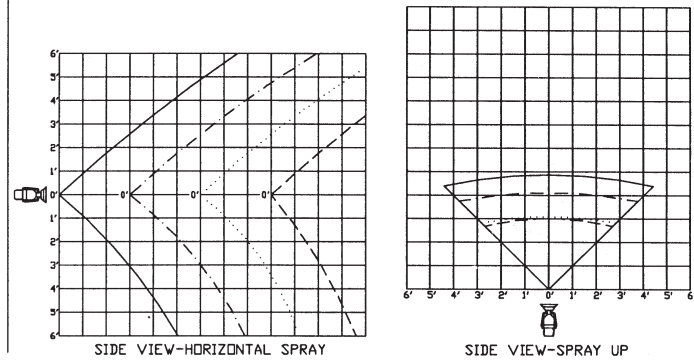
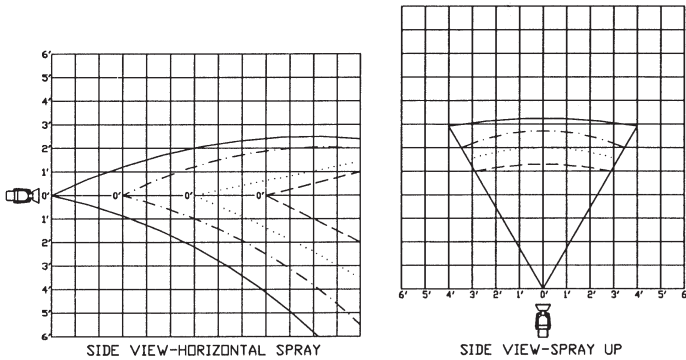
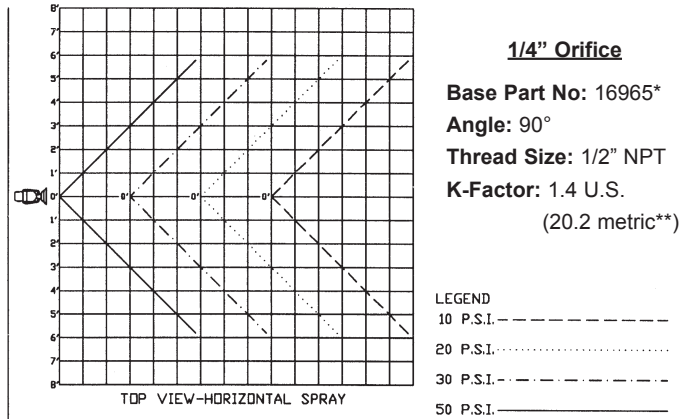
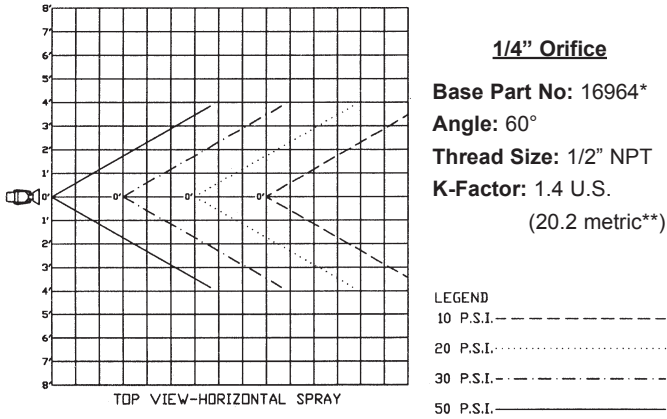

Scale: Each square equals one square foot.  
 \* Part number shown is the base part number. For complete part number, refer to current Viking price list schedule.  
 \*\*Metric K-factor measurement shown is when pressure is measured in Bar. When pressure is measured in kPa, divide the metric K-factor shown by 10.0.

**THIS PAGE  
INTENTIONALLY  
LEFT BLANK**